

Energy-efficient, comfortable, versatile  
Catalogue 2018





## Efficient distribution

Theben stands for a clear commitment to the three-stage distribution approach via wholesaler and retail outlets. Our capacious central warehouse guarantees our goods are ready for delivery at all times.



## Reliable customer service

You can rely on us – even after the guarantee period expires: just in case our customer service is at your disposal quickly and uncomplicatedly. You will immediately receive the spare parts requested – even for older devices.



## Effective training

You can never have enough knowledge: especially about our products. We offer our customers a broad range of training options – at our own premises in Haigerloch or also in your vicinity at our sales partners. The entire Theben training program can be found at: [www.theben.de/training](http://www.theben.de/training)



## Most important trade fairs

You can find us at important trade fairs. There you can find out everything about our new products. Drop by: we look forward to your visit:  
E-world, Essen, 06/02–08/02/2018  
ISE, Amsterdam, 06/02–09/02/2018  
Middle East Electricity, Dubai, 06/03–08/03/2018  
light+building, Frankfurt, 18/03–23/03/2018  
belektro, Berlin, 06/11–08/11/2018  
GET Nord, Hamburg, 22/11–24/11/2018



## Personal contact

Some questions can't wait. Our experts will help you in a quick and straightforward way. Monday to Thursday from 7.00 am to 6.00 pm, Friday to 4.00 pm on the telephone. Or immediately by email.

↳ Telephone hotline: +49 7474 692-369

↳ Email hotline: [hotline@theben.de](mailto:hotline@theben.de)



## Information-packed website

All important information about our products can be found on our website. With just a few clicks the "Product finder" function takes you to the right product for your application.



## Digital newsletter

It couldn't be more convenient: our email newsletter informs you about interesting facts and news from us. Just register at [www.theben.de/en/email-newsletter](http://www.theben.de/en/email-newsletter)



## Social media

Whether praise, questions or suggestions: we look forward to your posts and provide you with up-to-date information via the following channels:



[xing.com/companies/thebenag](https://www.xing.com/companies/thebenag)



[plus.google.com/+TheThebenAG/](https://plus.google.com/+TheThebenAG/)



[youtube.com/user/TheThebenAG](https://youtube.com/user/TheThebenAG)



[www.facebook.com/ThebenAG/](https://www.facebook.com/ThebenAG/)



[twitter.com/Theben\\_AG](https://twitter.com/Theben_AG)



[de.linkedin.com/company/theben-ag](https://de.linkedin.com/company/theben-ag)

New products & LED expertise



## Time and light control

Digital time switches



Analogue time switches



Time relays/hour counters



Staircase time switches/  
dimmers



Twilight switches



## Presence and motion detectors

Presence detectors



Motion detectors/spotlights



## Climate control

Clock thermostats



Room thermostats



Sensor technology



## House and building control

KNX



Smart Home system LUXORliving/  
Living comfort control LUXOR



Logic controllers



## Accessories / appendix

Accessories, Index, Packaging units,  
List of discontinued models, Brochures,  
Terms and conditions, Agencies





Dear customers and partners,

When we talk about "news" and "innovations" at Theben, we do not always mean completely new products. Over the past few decades, we have developed a special flair and all-round expertise for achieving great effects through improving details.

For this reason, we do not immediately chase after all the latest trends. When we implement new technologies, you can be sure that our products give the best performance, efficiency and service life – with no superfluous functions.

In this catalogue, we present you with a range of innovative products and systems which reflect this philosophy. Some are completely new, others are purposefully improved – from our extremely simple to install and program LUXORliving smart home system to the new generation top3 time switches which can be programmed via a convenient app.

What's more, you will be introduced to a broad product range of new motion and presence detectors that is sure to meet every requirement, particularly in contract business. When it comes to house and building automation, you can also look forward to discovering products including the failsafe AMUN CO<sub>2</sub> sensor and the RAMSES 718 S/P room thermostats with their new design.

With this in mind, simply allow yourself to be inspired by our innovations great and small!

We look forward to continuing our excellent cooperation.  
Your Theben board, together with the whole team



Paul Sebastian Schwenk  
Management board

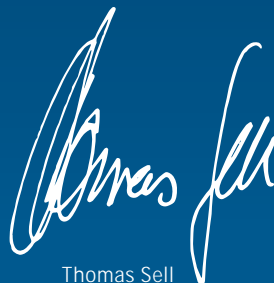

Thomas Sell  
Management board

SMARTPHONE-APP  
**NEW**  
IDEAL FOR LED



## Changing times: top2 becomes top3 Digital time switches

Further product information on page 26

With more than 10 million top2 devices sold worldwide, Theben time switches have been the standard in terms of functionality, ease of use and reliability for decades.

The new digital time switches of the top3 series replace the proven top2 devices and reach the next milestone in terms of performance, energy efficiency and programmability. Time switch programs can now be easily controlled using an app and transferred to the timer via Bluetooth Low Energy.

SELEKTA top3 astronomical time switches can be used for precise switching of connected consumers based on sunrise and sunset.



**This is how it works!**

Discover how easy programming and transferring can be with top3.  
[www.youtube.com/TheThebenAG](http://www.youtube.com/TheThebenAG)

Highlights at a glance



600 W  
LED output



Flexible  
programming



Secure  
transfer



100%  
compatible  
with top2

top3 app now available – see what it can do



**Clear management**  
Here you can create new programs, assign project names and manage them.



**Convenient settings**  
Make all important settings for your Astro program: coordinates or location information, time and date format and much more.



**Secure connection**  
Activate your top3 device for transfer and send the program via Bluetooth. Make sure the Bluetooth OBELISK top3 is inserted.



**Intuitively created**  
An individual time program is quickly and clearly created in the classic list view.



Simply smart.  
Simply LUXOR  
LUXORliving  
smart home system

Further product information on page 306

# New products

## LUXORliving smart home system

1

LUXORliving is the simple smart home system from Theben, offering all-round home comfort, whilst avoiding unnecessary waste. Switching lights on and off. Dimming. Regulating heating and controlling blinds. That's what it's all about. And the best thing: LUXORliving is so easy to assemble, install and use that you don't need to be a specialised fitter – unless you really want to!

Anyone who is building or renovating should include LUXORliving in their plans. The smart home system makes houses and flats more comfortable and provides a pleasant working atmosphere in offices and doctor's surgeries too. What's more, it creates optimum conditions for you to use your energy-saving potential.

### Highlights at a glance



Simple start-up



Free push button selection



Certified KNX system



Flexible BUS wiring



Safe panic function



Control centre OFF



Individual scenarios



Clever presence simulation

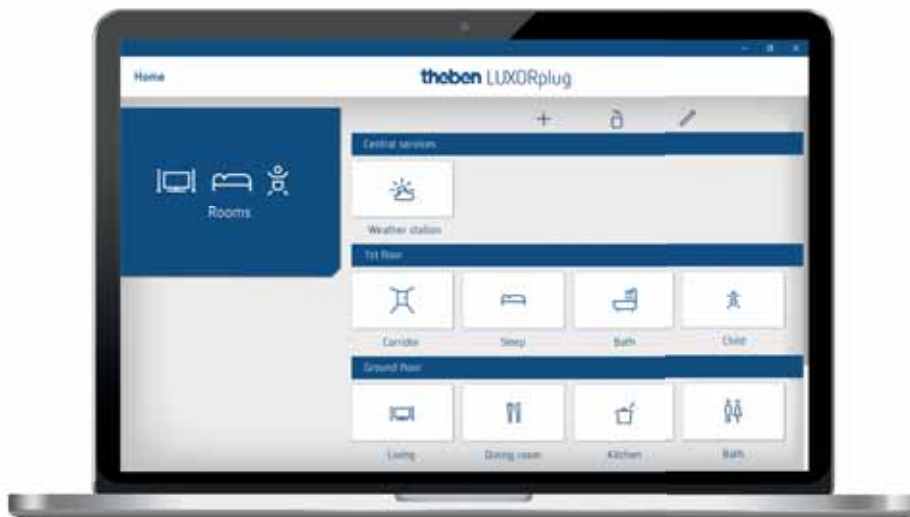

### LUXORplug

LUXORplug is the simple operating software from Theben. Windows-based – speedy, safe, simple. No prior knowledge necessary.



### LUXORplay

LUXORplay is the iOS and Android app for convenient, safe and really easy operation of LUXORliving via WLAN.



Acoustic, secure, flexible

Motion detectors for a whole host  
of applications



Acoustic  
function

### LUXA 103-100 UA motion detector with acoustic function

The new LUXA 103-100 UA motion detector is ideal for bathrooms and toilets, among others, thanks to the integrated microphone. While the motion detector is activated by the PIR sensor, the integrated microphone indicates the shut-off delay.



Secure  
from tam-  
pering

### theLuxa R motion detector for outdoor use

When motion detectors are to be installed in open access areas such as schoolyards, sports facilities or underground carparks, it all comes down to one thing: maximum sturdiness and reliable resistance against tampering. Like the new theLuxa R motion detectors.



powerful  
&  
compact

### theLeda S LED spotlight with motion detector

The new theLeda S LED spotlights are ideal for outdoor areas such as carports and the back entrances of buildings. The integrated lens boasts sophisticated mirror optics the PIR sensor. The 180° rotating LED module of the theLeda S10 allows for wall, façade and accent lighting so-called wash effects.

#### Highlights

- Compact design with flat housing and integrated power unit
- Precise configuration of the PIR sensor and microphone sensitivity incl. the microphone deactivation option
- Large detection area of max. 12 m with range limitation using the supplied cover clips
- Teach-in function for convenient brightness setting
- Flexible installation options: Ceiling installation using clamping brackets as well as flush-mounted or back fitting using the back box accessory

Further information on page 198.

#### Highlights

- Secure protection against tampering thanks to robust housing design with covered operating controls under the secured front cover
- Large detection area of 180° and max. 12 m (not configurable) thanks to an especially large lens with range limitation using the supplied cover clips
- Short and extended function via manual control
- Protection class IP 55 for reliable outdoor use

Further information on page 160.

#### Highlights

- Very long service life: 50,000+ operating hours thanks to optimised heat conduction via integrated aluminium cooling element
- High light output thanks to Matrix LED module with 10 W and 840 lumens
- Practical orientation light with configurable dimming level
- Short and extended function via manual control
- Protection class IP 55 for reliable outdoor use

Further information on page 172.

A photograph of two women in a modern office environment. The woman on the left, with long dark hair and bangs, is wearing a dark blue blazer and is smiling while offering a white coffee cup on a saucer to the woman on the right. The woman on the right has blonde hair, wears glasses, a pink top, a dark cardigan, and a dark skirt, and is smiling back while holding a glass of water. They are standing near a large window with a view of a city and hills. The background includes a light-colored wall and a yellow vertical panel on the left.

Quite simple. Ever-present.  
theRonda S360 KNX presence detector  
with flat design

Further information on page 272.

The new theRonda S360 KNX presence detectors for ceiling installation show off their strengths where a discreet design that blends in with the room and maximum cost efficiency are needed. For example, in individual offices, side rooms with daylight and wet rooms (protection class IP 54). theRonda 360 KNX FLAT DE is particularly impressive thanks to its super flat housing which is only 5 mm thick.



### Highlights at a glance



Round detection area max. 64 m<sup>2</sup>



Easy calibration of brightness measurement



Reliable teach-in function



Illuminating short stays



Self-learning time delay



Scenes



Splash proof

### Extensive detection:

Nothing escapes this detector. theRonda detects every seated motion within a 4-metre diameter. It can even cover an area of 64 m<sup>2</sup> (installation height 4 m).

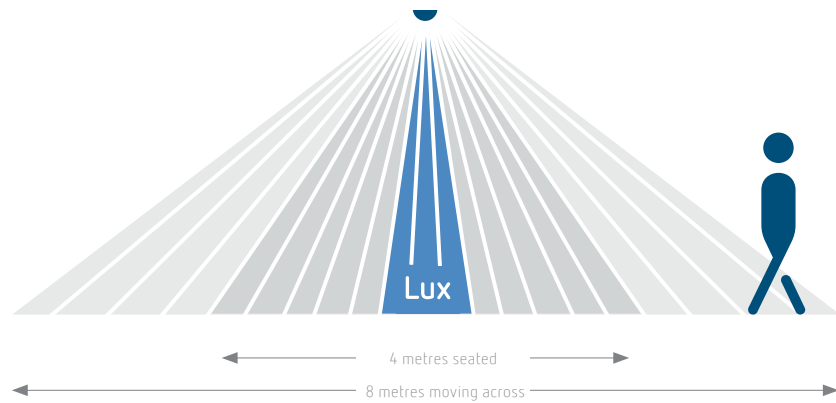

In addition to a ceiling installation version (theRonda S360 KNX FLAT DE), the theRonda S is also available in a surface-mounted version (theRonda S360 KNX AP).





High-quality solutions for  
KNX house and building automation



160 mA  
320 mA  
640 mA

### KNX power supplies

The core of each KNX system is – often completely underestimated – the KNX power supply. In this respect, the new KNX power supply sets new standards with regard to quality and stability. It provides power to KNX lines via the KNX output with integrated throttle.



LED  
dimmable

### KNX push button interfaces

The new KNX push button interfaces can create binary conditions, control indicator lamps via the outputs and measure temperature. If potential-free push buttons or switches are connected, they can perform different functions, such as switching, dimming, blinds, etc.



### DALI Gateway KNX plus

With the new DALI Gateway KNX plus, lighting colour, brightness and colour temperature can be set according to DT8 via KNX command. At one DALI output, up to 64 EBs can be individually controlled and up to 16 groups can be switched, dimmed or set to a defined value.

#### Highlights

- Broad product range: KNX power supplies for 160 mA, 320 mA and 640 mA
- Maximum long-term stability: Optimised construction and high-quality components for greater reliability thanks to less static and minimised voltage peaks
- Standardised housing: 4TE for all product variants
- Minimum power loss of just 1.5 W (160 mA), 2.3 W (320 mA) and 3.5 W (640 mA)

Further information on page 297.

#### Highlights

- Up to three different telegrams per channel in the function types „push-button“ and „switch“, as well as different states with short, long and double click
- Flexible LED control: Thanks to an increased output power of 3 mA, customary LEDs and low current LEDs can be controlled
- Inputs for measuring the temperature: From - 5 °C to + 100 °C.

Further information on page 256.

#### Highlights

- Lighting colour and brightness can be set and tunable white controlled in accordance with DT8
- Connection of up to 64 DALI units to one DALI output
- Operation of self-contained-battery emergency luminaires in accordance with EN 62386-202, as well as emergency lighting systems with a central battery
- Status and error information for visualisation
- Scenario module for up to 16 different groups
- Effect module for sequential control

Further information on page 295.



For a perfect indoor climate  
More efficient heating made simple



°C/F  
& hPA  
integrated

### CO<sub>2</sub> sensor AMUN 716 S KNX

The new AMUN 716 S KNX CO<sub>2</sub> sensor monitors CO<sub>2</sub> levels in schools and classrooms, in offices and meeting rooms, or even in passive and low-energy buildings. Thanks to the integrated temperature controller this is ideal for efficiently controlling the room temperature and for controlling ventilation systems in KNX building installations depending on the air in the room.

The new AMUN 716 SR is ideal for conventional room air control without KNX technology.



Switch &  
wall box

### RAMSES 718 S/P KNX room thermostats

The new RAMSES 718 S/P KNX room thermostats are the optimum successors of the tried-and-tested RAMSES 712/713 devices. They support the heating control in KNX building automation in a constant or 2-point model. Thanks to the universal mounting plate they can be installed on the wall or a switch box.



Valve  
protec-  
tion

### HMT 6 S/12 S KNX heating actuators

The new HMT 6S/12S KNX heating actuators from Theben can be easily fitted in the heating circuit distributor. KNX heating actuators offer a range of high-performance functions which significantly increase the energy efficiency of the heating system.

#### Highlights

- Simple installation thanks to four measurement sizes in one device (CO<sub>2</sub>, relative humidity, temperature, air pressure)
- Integrated temperature controller for controlling KNX actuators or heating actuators
- Flexible application: Two front panels for setting the basic target value or for manual adjustment (absolute or relative scaling)
- Four external inputs for easy integration of conventional contacts such as switches, push-buttons, window and signal contacts

Further information on page 264.

#### Highlights

- Optimum visibility of the LED status displays thanks to the high light output of the LEDs incl. dimming function in the dark
- Flexible application: Two front panels for setting the basic target value or for manual adjustment (absolute or relative scaling)
- Four external inputs for simple integration of conventional contacts, such as switches, push buttons, window and signalling contacts

Further information on page 258.

#### Highlights

- Flow temperature adjustment to meet requirements: Automatic calculation of the maximum actuating value for energy-efficient adjustment of the actuating value to actual requirements
- No KNX room thermostat needed: Flexible use of each channel as a heating actuator or heating controller
- Variable output signal: For controlling 24 V or 0-10 V actuators.
- Integrated relay for controlling the heating circuit pump.

Further information on page 262.



## LEDs – Energy savers with a bright future and little quirks

LEDs have progressed enormously in recent years. Thanks to the improvements in the degree of efficiency and colour rendering index, there is almost no area of lighting technology where they are not present: as retrofit versions, they are a welcome alternative to unpopular energy-saving lamps. As illuminated strips and surfaces, they snuggle against every surface and thus allow completely new possibilities for light design. Even the first high-performance devices, such as stage and studio spotlights, are already available as LED versions.

However, not every bulb can easily be replaced by an LED retrofit lamp. This may lead to significant faults in the installation – surprisingly even with simple switching. The reason for this are the short but extremely high inrush currents. They can be a thousand times and more than the rated output. Contacts could burn through or fuse as a result.

## The challenge for LEDs and how to deal with it



The difficulties with such everyday tasks such as switching or dimming are surprising. The problem is that there are no uniform standards, especially for LED lamps yet.

The general guidelines for lamps apply to LED lamps, from the version of the socket to the measurement setup for the luminous intensity. However, whatever happens in-between is not recorded. As opposed to a classic lamp with simple spiral-wound filament, LED lamps include a lot of electronics for control purposes. Every manufacturer can decide the layout of these themselves. The manufacturer of switching and dimming devices currently does not have any reference points as to which electronics it controls and as to how the lamp behaves. The respective standards currently only exist as a draft.

### **No standards available? Then we will test it ourselves!**

If special switching loads for LED lamps and discharge lamps are not specified on a product, one can assume that the product has not been approved for these. However, the specifications for LED loads are not always helpful. Which inrush currents does the device manufacturer assume? These may differ from lamp to lamp. You should also be careful when adding. Several LEDs with low rated output may have higher inrush currents when added together than one single LED with the respective total output.

In order to be able to specify the load specifications for switching devices and dimmers, Theben conducts ongoing measurements on all conventional retrofit lamps. During these tests, the switching devices run through at least 40,000 switching cycles. This allows us to make reliable statements for the switchable loads.

# Contact killer LED

## Low consumption in use, wasteful when switched on

**A simple scenario:** In the staircases of a large residential building, the building management replaces the light bulbs with LED retrofit lamps. A specialist measures and verifies the prescribed brightness. The potential for savings is promising: in addition to the more favourable energy consumption, the long service life should reduce maintenance costs.

**But suddenly the staircase light timer switches fail.** An examination shows scorched or fused contacts: the devices were obviously overloaded, although the rated output of the installation was reduced significantly.

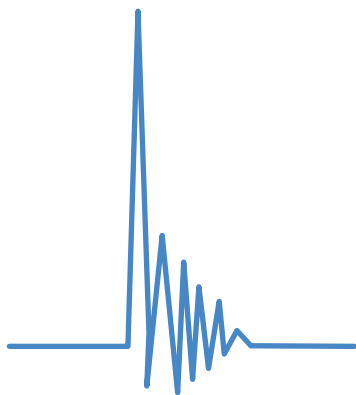

### Hard work for the contacts

#### Capacitive switching loads

How can an LED lamp that only has a few watts of rated output destroy a switching contact that has been dimensioned for several times that? Upon closer inspection, the answer is found in the inrush currents: in light bulbs, the typical inrush currents of the cold spiral coil cause ten times the respective rated current. In LED lamps and energy-saving lamps with their capacitive characteristics, one finds inrush current pulses in the  $\mu\text{s}$  range that could be a 1000 times and more than the rated current.

A measurement in our test laboratory authorised by the VDE has shown that in a particularly unfavourable case, an inrush current of 19 A with a 1.8 W LED lamp is 1706 times the rated output!

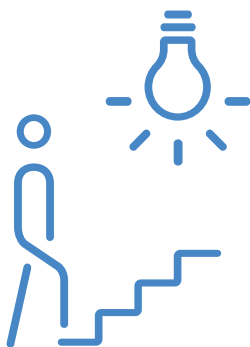

### Watch your step!

#### Switch-off pre-warning

At this point, we also wish to draw attention to problems with the switch-off pre-warning (flashing twice or similar according to DIN 18015-2): the flashing is not reliably visible, as the switching-off process is buffered by the electronic ballasts or capacitors of the LEDs. Switching several times additionally impairs the service life of the device.

# This is how LED lamps are switched

## With the right contact at the right time



10 A-10 AX  
230 V~

### Two contacts for all switching cases: Tungsten pre-contact

High currents require special contacts. Alongside silver tin oxide ( $\text{AgSnO}_2$ ), Theben uses a combination of two contacts closing one after the other: tungsten pre-contacts. The leading contact consists of high-resistance and very durable tungsten.

It captures the inrush current and limits it at the same time. As a result, the low-resistance main contact remains unloaded from the switching peaks.

Theben uses these relays in the digital time switches TR 609 top2 S and SELEKTA 175 top2 as well as with the performance motion detectors theLuxa P and the presence detector theRonda P.



### Switching at precisely the right time: Zero-cross switching

Switching devices that are designed for the C-load generally deal with the inrush currents in a better manner. Theben uses a particularly efficient solution, known as zero-cross switching. It calculates the zero-crossing of the sine curve of the alternating voltage. At this moment, the inrush current is at its minimum during switching. This protects the relay contact and extends its service life, even at nominally high switching loads. Almost all of the devices of the top2 series are equipped with the motion detector theLuxa S and the presence detector PlanoCentro.



### Environmentally aware and safe switching: Cadmium-free contacts

Cadmium oxide was thought to have been the ideal contact material for high inrush currents. However, it is now forbidden according to the RoHS guidelines, although there are exceptions for electrical switching contacts. Nevertheless, Theben had switched to environmentally friendly  $\text{AgSnO}_2$  materials at the turn of the millennium.

These offer comparably good, in some cases even better contact and switching properties, such as higher burn-off resistance, increased resistance against electric wear and a significantly reduced tendency for material migration during direct current operation.

# Dimming LEDs?

## Not something that should be taken for granted!

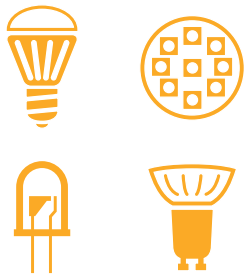

### Dimmable or not? Making the right choice is crucial

Not every LED lamp is dimmable. Even with suitable versions, the dimming characteristics differ significantly and depending on the manufacturer. LEDs frequently flicker and cannot be dimmed linearly and harmonically, as the required electronic ballasts react with great differences to the leading and trailing edge. This is why some manufacturers only explicitly allow one of the methods.



### Unwanted continuous light Residual currents are sufficient

Another problem is caused by the interference suppression capacitors of the dimmer. Very low residual currents continuously run through them. These are sufficient to supply LED lamps with one to two watts of rated output. They therefore never go out completely.

A similar effect can be caused by long lines positioned in parallel.



### Dimmer meets lamp Not all of them are compatible

For infinitely variable control, not only does the LED lamp have to be dimmable, but the dimmer also has to be LED-compatible. Theben has developed several solutions for this purpose:

- Presets for different LED lamps
- Dimming curves that can be reloaded via ETS

# Dimming LEDs!

## Theben can

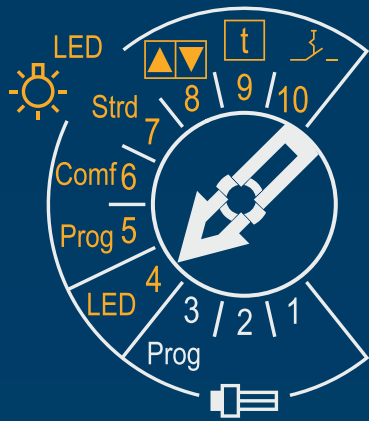

## A matter of settings

### Selecting presets

LED-compatible switching devices from Theben, such as the universal dimmer DIMAX 534 plus, offer additional setting options for a perfect adaptation to this technology.

A minimum brightness for LED lamps with low wattage can be set using potentiometers and rotary switches. Even the type of control, phase angle or trailing-edge phase control can be preselected. This practically allows all dimmable LED lamps of renowned manufacturers to be controlled reliably.

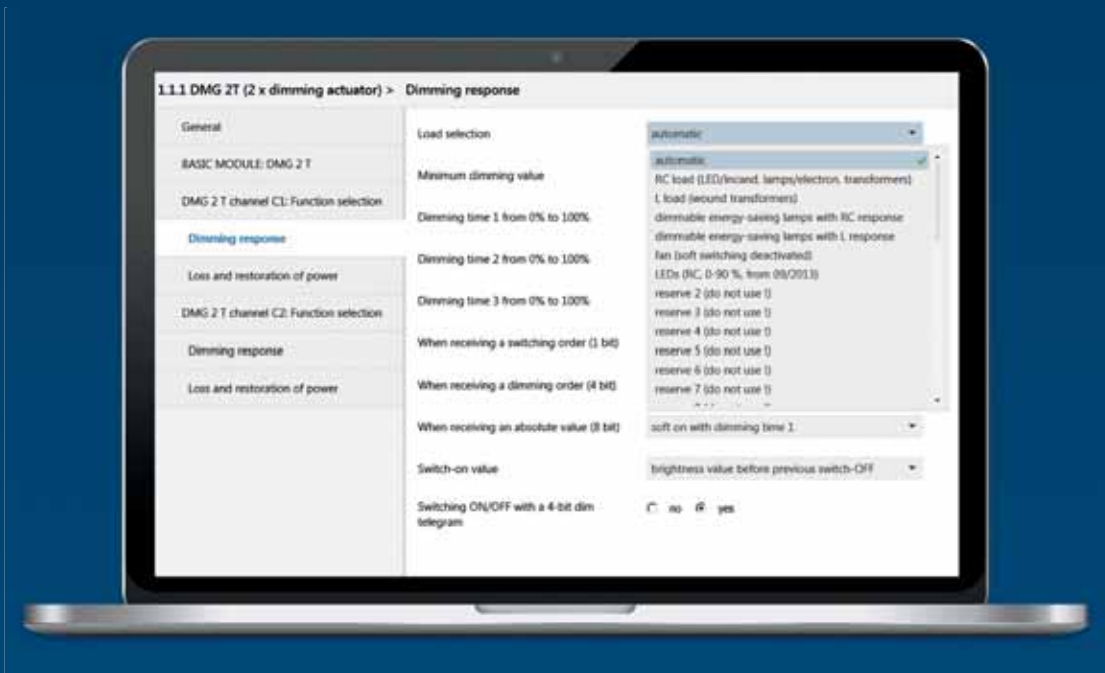

## Up to date with KNX

### Reloading dimming curves



The KNX universal dimmer actuator from Theben goes one step further: the ETS programming software stores various dimming curves, which correct the dimming response appropriately depending on the lamp used, thus ensuring seamless, infinitely variable dimming.

Another advantage of the new dimming actuators is the ability to extend the dimming curves. New dimming curves — e.g. for future lamps — can be imported via ETS. With this update capability, KNX dimming actuators ensure your investments are well-protected.



Program	Number of channels	Memory locations	External inputs	PC Interface	Memory card supplied	Type of connection	Type	Page
---------	--------------------	------------------	-----------------	--------------	----------------------	--------------------	------	------

### DIN rail, 2 modules

	Weekly program	1	56	–	✓	–	DuoFix spring terminals	TR 610 top3	26
		2	56	–	✓	–	DuoFix spring terminals	TR 612 top3	26
		1	84	1	✓	✓	DuoFix spring terminals	TR 611 top2 TR 611 top2 RC	28 28
		2	84	2	✓	✓	DuoFix spring terminals	TR 622 top2	28
	Weekly program, astronomical program	1	56	–	✓	–	DuoFix spring terminals	SELEKTA 170 top3	30
		2	56	–	✓	–	DuoFix spring terminals	SELEKTA 174 top3	30
		1	84	1	✓	–	DuoFix spring terminals	SELEKTA 171 top2 RC	30
		2	84	2	✓	–	DuoFix spring terminals	SELEKTA 172 top2	30

### DIN rail, 3 modules

	Yearly program, astronomical program	1	800	1	✓	–	DuoFix spring terminals	TR 641 top2	32
						✓	DuoFix spring terminals	TR 641 top2 RC	32
		2	800	2	✓	–	DuoFix spring terminals	TR 642 top2	32
						✓	DuoFix spring terminals	TR 642 top2 RC	32
–	–	–	–	–	–	DuoFix spring terminals	EM LAN top2	34	

### DIN rail, 4 modules

	Yearly program, astronomical program	4	800	4	✓	–	DuoFix spring terminals	TR 644 top2	32
						✓	DuoFix spring terminals	TR 644 top2 RC	32
	–	4	–	4	–	–	DuoFix spring terminals	EM 4 top2	34

### DIN rail, 1 module

	Weekly program	1	56	–	✓	–	DuoFix spring terminals	TR 608 top2 S	36
			84	1	✓	–	DuoFix spring terminals	TR 609 top2 S	36
	Weekly program, astronomical program	1	56	1	✓	–	DuoFix spring terminals	SELEKTA 175 top2	36

### Front panel installation/wall installation

	Weekly program	1	84	–	✓	–	Screw terminals	TR 635 top2	38
		2	84	–	✓	–	Screw terminals	TR 636 top2	38

### Wall installation

	Weekly program	1	56	–	–	–	–	TR 684-1 top2	40
		2	56	–	–	–	–	TR 684-2 top2	40

### Flush-mounted wall installation

	Weekly program	2	–	–	–	–	Screw terminals	theRolla P032	42
								theRolla S031	42

### Plug-in

	Weekly program	1	36	–	–	–	Plug-in	theben-eltimo 020 S	44
			33	–	–	–		theben-eltimo 020 S DCF	44

# Time and light control

## Digital time switches, DIN rail, 2 modules

2



TR 610 top3

TR 612 top3

TR 612 top2

### Description

#### Common functions

- Digital time switch with weekly program
- DuoFix spring terminals
- Text-oriented user guidance in display
- 56 memory locations
- Interface for OBELISK top2 memory card (PC programming)
- 10 year power reserve (lithium battery)
- Zero-cross switching for relay-saving switching and high lamp loads (not with 24 V devices)
- ON-OFF switching times
- Switching preselection
- Permanent switching ON/OFF
- Integrated operating hour counter

- Holiday program
- Display back light (can be turned off)
- PIN coding
- Automatic summer / winter time changeover

#### TR 610 top3

- 1 channel
- Programming by app possible
- Safe transfer via optional Bluetooth Low Energy OBELISK top3
- Maximum manipulation security, time switch programs can only be transferred from the app to the time switch when the Bluetooth OBELISK top3 is plugged into the time switch
- 100 % compatible with top2

#### TR 612 top3

- 2 channels
- Programming by app possible
- Safe transfer via optional Bluetooth Low Energy OBELISK top3
- Maximum manipulation security, time switch programs can only be transferred from the app to the time switch when the Bluetooth OBELISK top3 is plugged into the time switch
- 100 % compatible with top2

#### TR 610 top2

- 1 channel

#### TR 612 top2

- 2 channels

### Product selection

Program	Program functions	Number of channels	Switching load < 1 mA	Operating voltage	Type	Article number
Weekly program	ON-OFF	1	-	230 V AC	TR 610 top3	6100130
		2	-	230 V AC	TR 612 top3	6120130
		1	-	230-240 V AC	TR 610 top2	6100100
			✓	230-240 V AC	TR 610 top2 G	6100110
			-	12-24 V UC	TR 610 top2 24V	6104100
		2	-	230-240 V AC	TR 612 top2	6120100
			12-24 V UC	TR 612 top2 24V	6124100	

### Technical data

	TR 610 top3	TR 612 top3	TR 610 top2 G	TR 610 top2 24V	TR 612 top2 24V
Operating voltage	230 V AC		230–240 V AC	12–24 V UC	12–24 V UC
Frequency	50–60 Hz				
Width	2 modules				
Installation type	DIN rail				
Type of contact	Changeover contact	Two-way changeover contact	Changeover contact		Two-way changeover contact
Power reserve	10 years				
Switching capacity at 250 V AC, $\cos \varphi = 1$	16 A				
Switching capacity at 250 V AC, $\cos \varphi = 0,6$	10 A		2 A	2 A	
Incandescent/halogen lamp load	2600 W		1400 W	1400 W	
Energy saving lamps	1100 W		30 W	30 W	
LED lamp < 2 W	50 W		6 W	6 W	
LED lamp 2-8 W	600 W		20 W	20 W	
LED lamp > 8 W	600 W		25 W	25 W	
Switching capacity min.	ca. 10 mA		< 1 mA	ca. 10 mA	
Shortest switching times	1 min				
Time accuracy at 25 °C	typical $\pm 0,25$ s/day (quartz)				
Stand-by consumption	0,4 W		0,8 W	0,3 W	0,3 W
Test approval	–		–		–
Type of protection	IP 20				
Protection class	II according to EN 60 730-1				
Ambient temperature	–30 °C ... +55 °C				

### Accessories

**Front panel kit**

Details page 334

**Wall mounting kit 35 mm**

Details page 334

**Bluetooth OBELISK top3**

Details page 335

**Memory card OBELISK top2**

Details page 335

**PC set OBELISK top2/3**

Details page 335

### Connection diagrams

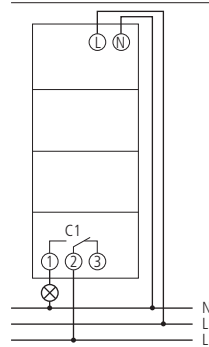

TR 610 top3, TR 610 top2

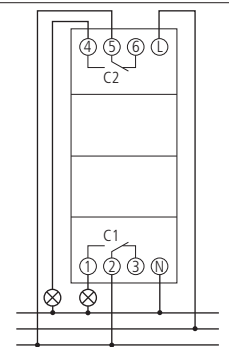

TR 612 top3, TR 612 top2

# Time and light control

## Digital time switches, DIN rail, 2 modules

2



### Description

#### Common functions

- Digital time switch with weekly program
- DuoFix spring terminals
- Text-oriented user guidance in display
- 84 memory locations
- Interface for OBELISK top2 memory card (PC programming)
- OBELISK memory card included in delivery
- 10 year power reserve (lithium battery)
- Zero-cross switching for relay-saving switching and high lamp loads (not with 24 V devices)
- ON-OFF switching times
- Pulse program

- Cycle program
  - Switching preselection
  - Permanent switching ON/OFF
  - Timer countdown
  - Integrated operating hour counter
  - Holiday program
  - 2 random programs
  - Display back light (can be turned off)
  - PIN coding
  - Automatic summer / winter time changeover
- TR 611 top2
- 1 channel
  - External input

#### TR 611 top2 RC

- Time synchronisation option via connection of an external DCF or GPS antenna (GPS not with 24 V device)
- Additional power unit required for GPS if only one device is connected to the antenna
- 1 channel
- External input

#### TR 622 top2

- 2 channel
- 2 external inputs

### Product selection

Program	Program functions	Number of channels	External inputs	Time basis	Operating voltage	Type	Article number
Weekly program	ON-OFF, Pulse, Cycle	1	1	Quartz	230–240 V AC	TR 611 top2	6110100
					12–24 V UC	TR 611 top2 24V	6114100
		2	2	Quartz	230–240 V AC	TR 611 top2 RC	6110300
					12–24 V UC	TR 611 top2 RC 24V	6114300
					230–240 V AC	TR 622 top2	6220100
					12–24 V UC	TR 622 top2 24V	6224100

### Technical data

	TR 611 top2	TR 611 top2 24V	TR 611 top2 RC	TR 611 top2 RC 24V	TR 622 top2	TR 622 top2 24V
Operating voltage	230–240 V AC	12–24 V UC	230–240 V AC	12–24 V UC	230–240 V AC	12–24 V UC
Frequency	50–60 Hz					
Width	2 modules					
Installation type	DIN rail					
Type of contact	Changeover contact				Two-way changeover contact	
Power reserve	10 years					
Switching capacity at 250 V AC, $\cos \varphi = 1$	16 A					
Switching capacity at 250 V AC, $\cos \varphi = 0,6$	10 A	2 A	10 A	2 A	10 A	2 A
Incandescent/halogen lamp load	2600 W	1400 W	2600 W	1400 W	2600 W	1400 W
Energy saving lamps	170 W	30 W	170 W	30 W	170 W	30 W
LED lamp < 2 W	30 W	6 W	30 W	6 W	30 W	6 W
LED lamp 2–8 W	100 W	20 W	100 W	20 W	100 W	20 W
LED lamp > 8 W	120 W	25 W	120 W	25 W	120 W	25 W
Switching capacity min.	ca. 10 mA					
Shortest switching times	1 s					
Time accuracy at 25 °C	typical $\pm 0,25$ s/day (quartz)		typical $\pm 0,25$ s/day (quartz) or DCF77/ GPS		typical $\pm 0,25$ s/day (quartz)	
Stand-by consumption	0,8 W	0,3 W	1,4 W	0,9 W	0,8 W	0,3 W
Test approval		–		–		–
Type of protection	IP 20					
Protection class	II according to EN 60 730-1					
Ambient temperature	–30 °C ... +55 °C					

### Accessories



**PC set OBELISK top2/3**  
↳ Art.No.: 9070409  
Details page 335



**Memory card OBELISK top2**  
↳ Art.No.: 9070404  
Details page 335



**Wall mounting kit 35 mm**  
↳ Art.No.: 9070064  
Details page 334

**Front panel kit**  
Details page 334

**Antenna top2 RC-DCF**  
Details page 335

**Antenna top2 RC-GPS**  
Details page 335

**Power unit top2 GPS**  
Details page 336

### Connection diagrams

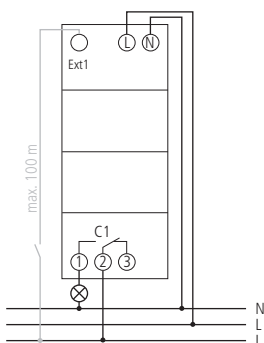

TR 611 top2

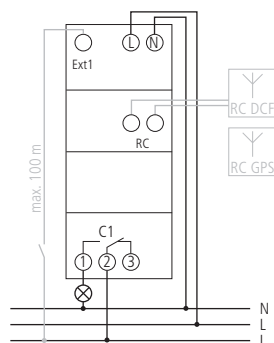

TR 611 top2 RC

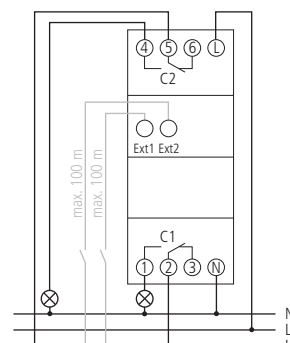

TR 622 top2

# Time and light control

## Digital time switches, DIN rail, 2 modules

2



SELEKTA 170 top3

SELEKTA 174 top3

SELEKTA 172 top2

### Description

#### Common functions

- Astronomical time switch with weekly program
- Astronomical time switch function (automatic calculation of sunrise and sunset times for the whole year)
- DuoFix spring terminals
- Text-oriented user guidance in display
- Interface for OBELISK top2 memory card (PC programming)
- 10 year power reserve (lithium battery)
- Zero-cross switching for relay-saving switching and high lamp loads (not with 24 V devices)
- Calculated astronomical switching times
- Programmable ON-OFF switching times
- Switching preselection
- Permanent switching ON/OFF
- Integrated operating hour counter
- Holiday program
- Display back light (can be turned off)

- PIN coding
- Automatic summer/winter time changeover

#### SELEKTA 170 top3

- 1 channel
- 56 memory locations
- Programming by app possible
- Safe transfer via optional Bluetooth Low Energy OBELISK top3
- Maximum manipulation security, time switch programs can only be transferred from the app to the time switch when the Bluetooth OBELISK top3 is plugged into the time switch
- 100 % compatible with top2

#### SELEKTA 174 top3

##### As SELEKTA 170 top3:

- 2 channels

#### SELEKTA 171 top2 RC

- 1 channel
- External input

- Time synchronisation via connection of external DCF or GPS antennas, additional positioning for astronomical program with GPS (GPS not with 24 V device)
- Additional power unit (9070892) required for GPS if only one device is connected to the antenna
- 84 memory locations
- 3 special programs with yearly date function per channel
- Count-down timer

#### SELEKTA 172 top2

- 2 channels
- 84 memory locations
- Channel 1 or channel 2 can also be used purely as time switch channel
- 2 external inputs
- 3 special programs with yearly date function per channel
- Count-down timer

### Product selection

Program	Number of channels	External inputs	Time basis	Operating voltage	Type	Article number
Weekly program, astronomical program	1	–	Quartz	230 V AC	SELEKTA 170 top3	1700130
	2	–	Quartz	230 V AC	SELEKTA 174 top3	1740130
	1	–	Quartz	12–24 V UC	SELEKTA 170 top2 24V	1704100
		1	Quartz/DCF77/GPS	230–240 V AC	SELEKTA 171 top2 RC	1710100
			12–24 V UC	SELEKTA 171 top2 RC 24V	1714100	
	2	2	Quartz	230–240 V AC	SELEKTA 172 top2	1720100
				12–24 V UC	SELEKTA 172 top2 24V	1724100

# Time and light control

## Digital time switches, DIN rail, 2 modules

2

### Technical data

	SELEKTA 170 top3	SELEKTA 174 top3	SELEKTA 170 top2 24V	SELEKTA 171 top2 RC	SELEKTA 171 top2 RC 24V	SELEKTA 172 top2 24V
Operating voltage	230 V AC		12–24 V UC	230–240 V AC	12–24 V UC	12–24 V UC
Frequency	50–60 Hz					
Width	2 modules					
Installation type	DIN rail					
Type of contact	Changeover contact					Two-way changeover contact
Power reserve	10 years					
Switching capacity at 250 V AC, $\cos \varphi = 1$	16 A					
Switching capacity at 250 V AC, $\cos \varphi = 0,6$	10 A		2 A	10 A	2 A	2 A
Incandescent/halogen lamp load	2600 W		1400 W	2600 W	1400 W	1400 W
Energy saving lamps	1100 W		30 W	170 W	30 W	30 W
LED lamp < 2 W	50 W		6 W	30 W	6 W	6 W
LED lamp 2-8 W	600 W		20 W	100 W	20 W	20 W
LED lamp > 8 W	600 W		25 W	120 W	25 W	25 W
Fluorescent lamp load (electronic ballast)	–		180 VA	650 W	180 VA	180 VA
Switching capacity min.	ca. 10 mA					
Shortest switching times	1 min					
Time accuracy at 25 °C	typical $\pm 0,25$ s/day (quartz)			typical $\pm 0,25$ s/day (quartz) or DCF77/GPS		typical $\pm 0,25$ s/day (quartz)
Stand-by consumption	0,4 W		0,2 W	1,4 W	0,8 W	0,2 W
Test approval	–		–		–	–
Type of protection	IP 20					
Protection class	II according to EN 60 730-1					
Ambient temperature	-30 °C ... +55 °C					

### Accessories



PC set OBELISK top2/3  
↳ Art.No.: 9070409  
Details page 335



Memory card OBELISK top2  
↳ Art.No.: 9070404  
Details page 335



Wall mounting kit 35 mm  
↳ Art.No.: 9070064  
Details page 334

Front panel kit  
Details page 334

Antenna top2 RC-DCF  
Details page 335

Antenna top2 RC-GPS  
Details page 335

Power unit top2 GPS  
Details page 336

### Connection diagrams

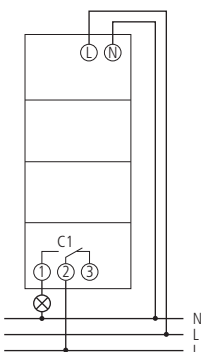

SELEKTA 170 top3

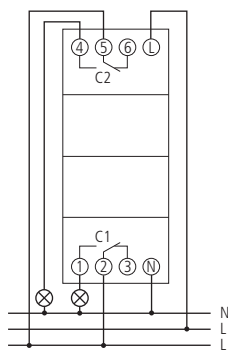

SELEKTA 174 top3

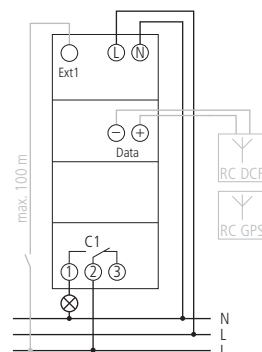

SELEKTA 171 top2 RC

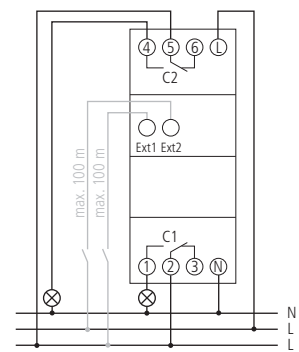

SELEKTA 172 top2

# Time and light control

## Digital time switches, DIN rail, 3 modules, 4 modules

2



TR 641 top2

TR 642 top2 RC

TR 644 top2

### Description

#### Common functions

- Digital time switch with yearly and astronomical time program
- DuoFix spring terminals
- Text-oriented user guidance in display
- 800 memory locations
- Interface for OBELISK top2 memory card (PC programming)
- 8 year power reserve (lithium battery)
- Zero-cross switching for leay-saving switching and high lamp loads (not with 24 V devices)
- Automatic summer /winter time changeover
- ON-OFF switching times
- Pulse program
- Cycle program
- Extensive yearly clock functions
- Astronomical time switch function (automatic calculation of sunrise and sunset times for the whole year)
- Switching preselection

- Permanent switching ON/OFF
- Count-down timer
- Integrated operating hour counter
- Holiday program
- 2 random programs
- Display back light (can be turned off)
- PIN coding

#### TR 641 top2

- 1 channel
- External input

#### TR 641 top2 RC

- Time synchronisation via connection of external DCF or GPS antennas, additional positioning for astronomical program with GPS
- 1 channel
- External input
- Extension module can be connected
- Memory card OBELISK top2 included in delivery

#### TR 642 top2

- 2 channels
- 2 external inputs

#### TR 642 top2 RC

- As TR 641 top2 RC but:
- 2 channels
  - 2 external inputs

#### TR 644 top2

- 4 channels
- 4 external inputs

#### TR 644 top2 RC

- As TR 641 top2 RC but:
- 4 channels
  - 4 external inputs

### Product selection

Program	Number of channels	External inputs	Time basis	Memory card supplied	Program functions	Operating voltage	Type	Article number
Yearly program, astronomical program	1	1	Quartz	-	ON-OFF, Pulse, Cycle	110-240 V AC	TR 641 top2	6410100
			Quartz/DCF77/GPS	✓	ON-OFF, Pulse, Cycle	110-240 V AC	TR 641 top2 RC	6410300
	2	2	Quartz	-	ON-OFF, Pulse, Cycle	110-240 V AC	TR 641 top2 RC 24V	6414300
			Quartz/DCF77/GPS	✓	ON-OFF, Pulse, Cycle	110-240 V AC	TR 642 top2	6420100
			Quartz/DCF77/GPS	✓	ON-OFF, Pulse, Cycle	110-240 V AC	TR 642 top2 RC	6420300
			Quartz/DCF77/GPS	✓	ON-OFF, Pulse, Cycle	110-240 V AC	TR 642 top2 RC 24V	6424300
4	4	Quartz	-	ON-OFF, Pulse, Cycle	110-240 V AC	TR 644 top2	6440100	
		Quartz/DCF77/GPS	✓	ON-OFF, Pulse, Cycle	110-240 V AC	TR 644 top2 RC	6440300	

# Time and light control

## Digital time switches, DIN rail, 3 modules, 4 modules

2

### Technical data

	TR 641 top2	TR 642 top2	TR 641 top2 RC	TR 642 top2 RC	TR 644 top2	TR 644 top2 RC	TR 641 top2 RC 24V	TR 642 top2 RC 24V
Operating voltage	110–240 V AC						12–24 V UC	
Frequency	50–60 Hz							
Width	3 modules				4 modules		3 modules	
Installation type	DIN rail							
Power reserve	8 years							
Switching capacity at 250 V AC, cos φ = 1	16 A				2 x 16 A   2 x 10 A		16 A	
Switching capacity at 250 V AC, cos φ = 0,6	10 A							
Incandescent/halogen lamp load 230 V	2600 W				2300 W		1400 W	
Incandescent/halogen lamp load 120 V	1300 W				1150 W		–	
Energy saving lamps 230 V	37 x 7 W, 30 x 11 W, 26 x 15 W, 26 x 20 W, 11 x 23 W						7 x 7 W, 6 x 11 W, 5 x 15 W, 5 x 20 W, 4 x 23 W	
Energy saving lamps 120 V	18 x 7 W, 15 x 11 W, 13 x 15 W, 13 x 20 W, 11 x 23 W						–	
LED lamp < 2 W	50 W							
LED lamp 2–8 W	180 W							
LED lamp > 8 W	200 W							
Switching capacity min.	Approx. 10 mA							
Shortest switching time	1 s							
Time accuracy at 25 °C	≤ ± 0,5 s/day (quartz)		≤ ± 0,5 s/day (quartz) or DCF77/GPS		≤ ± 0,5 s/day (quartz)		≤ ± 0,5 s/day (quartz) or DCF77/GPS	
Stand-by consumption	0,6 W	0,6 W	1,2 W	1,2 W	0,5 W	1,3 W	1,5 W	
Type of protection	IP 20							
Protection class	II according to EN 60 730-1							
Ambient temperature	–30 °C ... +45 °C							

### Accessories



**EM 4 top2**  
for TR 641 top2 RC, TR 642 top2 RC, TR 644 top2 RC  
↳ Art.No.: 6490104  
Details page 34



**EM LAN top2**  
for TR 641 top2 RC, TR 642 top2 RC, TR 644 top2 RC  
↳ Art.No.: 6490900  
Details page 34



**Antenna top2 RC-DCF**  
for TR 641 top2 RC, TR 642 top2 RC, TR 644 top2 RC  
↳ Art.No.: 9070410  
Details page 335

**Wall mounting kits**  
Details page 334

**Front panel kit**  
Details page 334

**Antenna top2 RC-GPS**  
Details page 335

**Memory card OBELISK top2**  
Details page 335

**PC set OBELISK top2/3**  
Details page 335

### Connection diagrams

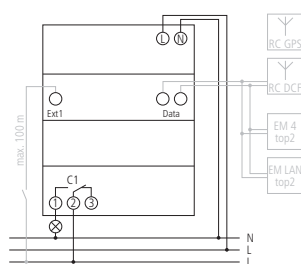

TR 641 top2 RC

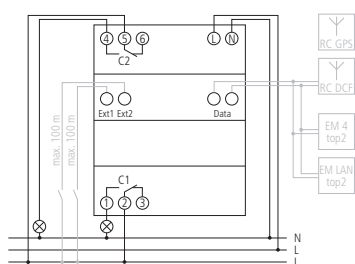

TR 642 top2 RC

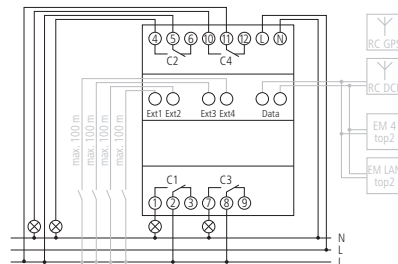

TR 644 top2 RC

## Time and light control

### Digital time switches, DIN rail, 3 modules, 4 modules

2



EM LAN top2



EM 4 top2

#### Description

##### EM LAN top2

- Ethernet communication module for remote access via LAN network to time switches TR 641 top2 RC, TR 642 top2 RC and TR 644 top2 RC
- Remote programming using OBELISK top2 PC software
- Direct remote access to time switch (e.g. reading out switching status, performing manual switching, checking time) with OBELISK top2 Software
- Width: 3 modules

##### EM 4 top2

- Extension module for TR 641 top2 RC, TR 642 top2 RC and TR 644 top2 RC
- 4 channels
- Width: 4 modules
- DuoFix spring terminals
- 4 external inputs
- Switching preselection
- Permanent ON/OFF switching
- 4 LEDs for displaying switching status

- Zero-cross switching for relay-saving switching and high lamp loads

#### Product selection

Type	Article number
EM LAN top2	6490900
EM 4 top2	6490104

# Time and light control

## Digital time switches, DIN rail, 3 modules, 4 modules

### Technical data

	EM LAN top2	EM 4 top2
Operating voltage	230 V AC	110–240 V AC
Frequency	50–60 Hz	
Width	3 modules	4 modules
Installation type	DIN rail	
Type of contact	–	Two-way switch
Switching capacity at 250 V AC, $\cos \varphi = 1$	–	16 A
Switching capacity channels 1+3	–	10 A
Switching capacity at 250 V AC, $\cos \varphi = 0,6$	–	10 A
Incandescent/halogen lamp load 230 V	–	2300 W
Incandescent/halogen lamp load 120 V	–	1150 W
Energy saving lamps 230 V	–	22 x 7 W, 18 x 11 W
Energy saving lamps 120 V	–	11 x 7 W, 9 x 11 W
Switching capacity min.	–	ca. 10 mA
Stand-by consumption	3,2 W	1,5 W
Type of protection	IP 20	
Protection class	II according to EN 60 730-1	
Ambient temperature	-30 °C ... +50 °C	-30 °C ... +55 °C

### Accessories



Wall mounting kit 52,5 mm

Details page 334

Wall mounting kit 70 mm

Details page 334

Front panel kit

↳ Art.No.: 9070001

Details page 334

### Connection diagrams

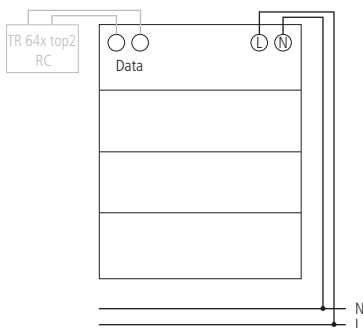

EM LAN top2

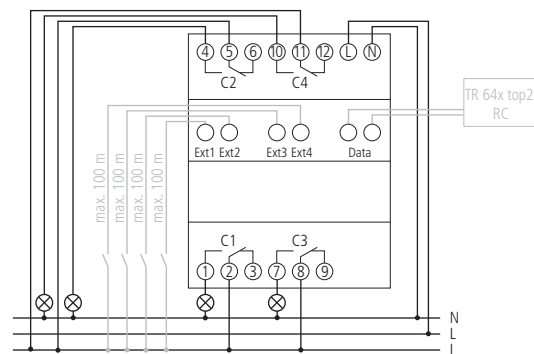

EM 4 top2

# Time and light control

## Digital time switches, DIN rail, 1 module

2



TR 608 top2 S

TR 609 top2 S

SELEKTA 175 top2

### Description

#### Common functions

- 1 channel
- DuoFix spring terminals
- Text-oriented user guidance in display
- Interface for OBELISK top2 memory card (PC programming)
- 10 year power reserve (lithium battery)
- Switching preselection
- Integrated operating hour counter
- Holiday program
- PIN coding
- Automatic summer / winter time changeover

#### TR 608 top2 S

- Digital time switch with weekly program
- 56 memory locations
- ON-OFF switching times
- Permanent switching ON/OFF

#### TR 609 top2 S

- Digital time switch with weekly program
- 84 memory locations
- External input
- Pulse program
- Cycle program
- Timer countdown
- 2 random programs
- ON-OFF switching times
- Permanent switching ON/OFF

#### SELEKTA 175 top2

- Astronomical time switch with weekly program
- External input
- 56 memory locations

- Astronomical time switch function (automatic calculation of sunrise and sunset times for the whole year)
- Offset for adjusting of sunrise and sunset times
- Calculated astronomical switching times
- Fixed ON-OFF switching times can be programmed (e.g. night time interruption)
- Permanent switching ON/OFF

### Product selection

Program	Number of channels	Memory locations	Program functions	Operating voltage	Type	Article number
Weekly program	1	56	ON/OFF	230–240 V AC	TR 608 top2 S	6080101
		84	ON/OFF/Pulse/Cycle	230–240 V AC	TR 609 top2 S	6090101
Weekly program, astronomical program	1	1	ON/OFF	230–240 V AC	SELEKTA 175 top2	1750100

### Technical data

	TR 608 top2 S	TR 609 top2 S	SELEKTA 175 top2
Operating voltage	230–240 V AC		
Frequency	50–60 Hz		
Width	1 module		
Installation type	DIN rail		
Type of contact	Changeover contact	NO contact	
Power reserve	10 years		
Switching capacity at 250 V AC, cos φ = 1	16 A		
Switching capacity at 250 V AC, cos φ = 0,6	4 A		
Incandescent/halogen lamp load 230 V	1000 W	2000 W	
Energy saving lamps 230 V	30 W	300 W	
LED lamp < 2 W	6 W	55 W	
LED lamp > 2 W	60 W	600 W	
Fluorescent lamp load (electronic ballast)	–		1200 W
Switching capacity min.	10 mA		
Shortest switching times	1 min		
Time accuracy at 25 °C	typical ± 0,25 s/day (quartz)		
Stand-by consumption	0,4 W		
Test approval			–
Type of protection	IP 20		
Protection class	II according to EN 60 730-1		
Ambient temperature	-25 °C ... +55 °C		

### Accessories

**Front panel kit**

Details page 334

**Wall mounting kit 17,5 mm**

Details page 334

**Memory card OBELISK top2**

Details page 335

**PC set OBELISK top2/3**

Details page 335

### Connection diagrams

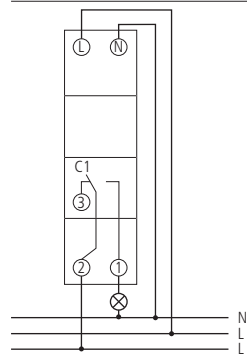

TR 608 top2 S

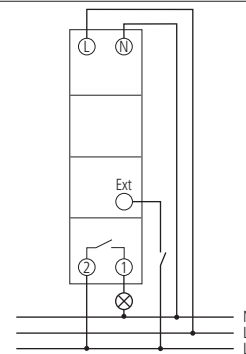

TR 609 top2 S, SELEKTA 175 top2

## Time and light control

### Digital time switches, Front panel installation/wall installation

2



TR 635 top2

TR 636 top2

#### Description

Common functions	- Switching preselection	TR 635 top2
- Digital time switch with weekly program	- Permanent ON/OFF switching	- 1 channel
- Text-based operator guidance in the display	- Count-down timer	TR 636 top2
- 84 memory locations	- Integrated hour counter	- 2 channels
- Interface for OBELISK top2 memory card (PC programming)	- Holiday program	
- 10 year power reserve (lithium battery)	- 2 random programs	
- ON-OFF switching times	- Back lighting (can be turned off)	
- Pulse program	- PIN coding	
- Cycle program	- Automatic summer / winter time changeover	

#### Product selection

Program	Number of channels	Memory locations	Program functions	Operating voltage	Type	Article number
Weekly program	1	84	ON-OFF, Pulse, Cycle	230–240 V AC	TR 635 top2	6350100
	2	84	ON-OFF, Pulse, Cycle	230–240 V AC	TR 636 top2	6360100

# Time and light control

## Digital time switches, Front panel installation/wall installation

2

### Technical data

	TR 635 top2	TR 636 top2
Operating voltage	230–240 V AC	
Frequency	50–60 Hz	
Installation type	Front panel installation/wall installation	
Type of contact	Changeover contact	
Power reserve	10 years	
Switching capacity at 250 V AC, $\cos \varphi = 1$	16 A	6 A
Switching capacity at 250 V AC, $\cos \varphi = 0,6$	10 A	6 A
Incandescent/halogen lamp load	2300 W	1200 W
Energy saving lamps 230 V	90 W	
LED lamp < 2 W	20 W	
LED lamp 2-8 W	50 W	
Shortest switching times	1 s	
Time accuracy at 25 °C	$\leq \pm 0,5$ s/day (quartz) at 25 °C	
Stand-by consumption	0,9 W	1,1 W
Type of protection	IP 20	
Protection class	II according to EN 60 730-1	
Ambient temperature	-30 °C ... +55 °C	

### Accessories



PC set OBELISK top2/3  
↳ Art.No.: 9070409  
Details page 335



Memory card OBELISK top2  
↳ Art.No.: 9070404  
Details page 335



Snap-on mounting 72 x 72  
↳ Art.No.: 9070071  
Details page 334

### Scale drawings

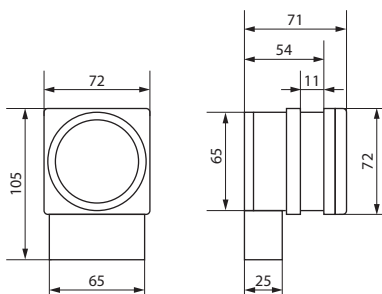

TR 635 top2, TR 636 top2

### Connection diagrams

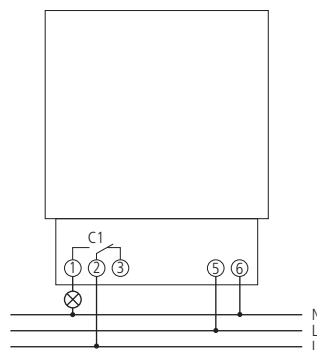

TR 635 top2

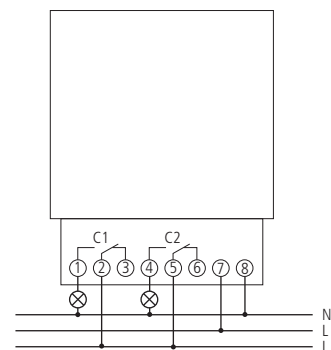

TR 636 top2

## Time and light control

### Digital time switches, Front panel installation/wall installation

2



TR 684-1 top2

TR 684-2 top2

#### Description

Common functions	- 10 year power reserve (lithium battery)	TR 684-1 top2
- Digital time switch with weekly program	- ON-OFF switching times	- 1 channel
- Timer module without plug-in base	- Switching preselection	TR 684-2 top2
- Connection by 4.8 mm AMP flat plug for original installation standard devices	- Permanent ON/OFF switching	- 2 channels
- For installation in regulation and control	- Integrated hour counter	
- Text-based operator guidance in the display	- Holiday program	
- 56 memory locations	- Back lighting (can be turned off)	
- Interface for OBELISK top2 memory card (PC programming)	- PIN coding	
	- Automatic summer / winter time changeover	

#### Product selection

Program	Number of channels	Memory locations	Program functions	Operating voltage	Type	Article number
Weekly program	1	56	ON-OFF	230–240 V AC	TR 684-1 top2	6840100
	2	56	ON-OFF	230–240 V AC	TR 684-2 top2	6840101

#### Technical data

	TR 684-1 top2	TR 684-2 top2
Operating voltage	230–240 V AC	
Frequency	50–60 Hz	
Installation type	Front panel installation/wall installation	
Type of contact	Changeover contact	
Power reserve	10 years	
Switching capacity at 250 V AC, cos φ = 1	6 A	
Switching capacity at 250 V AC, cos φ = 0,6	1 A	
Shortest switching times	1 min	
Time accuracy at 25 °C	≤ ± 0.5 s/day (quartz) at 25 °C	
Stand-by consumption	1 W	
Type of protection	IP 20	
Protection class	II according to EN 60 730-1	
Ambient temperature	-10 °C ... +55 °C	

Accessories



Multiple contact strip  
↳ Art.No.: 9075141  
Details page 334



PC set OBELISK top2/3  
↳ Art.No.: 9070409  
Details page 335



Memory card OBELISK top2  
↳ Art.No.: 9070404  
Details page 335

Scale drawings

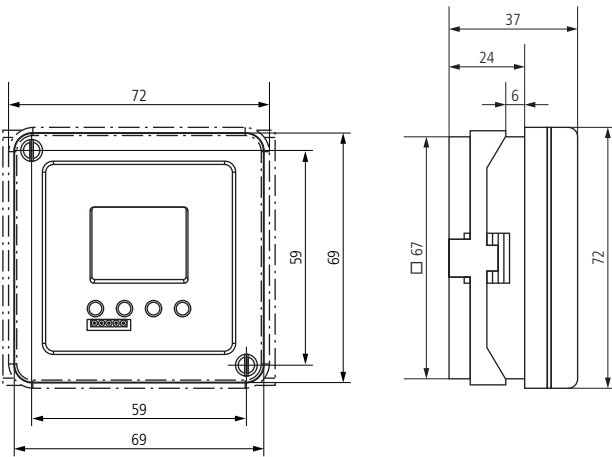

TR 684-1 top2, TR 684-2 top2

Connection diagrams

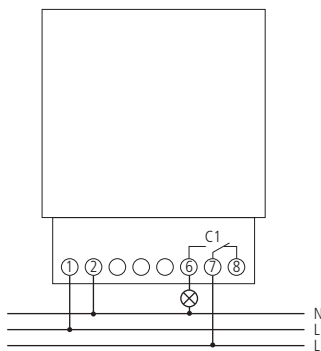

TR 684-1 top2

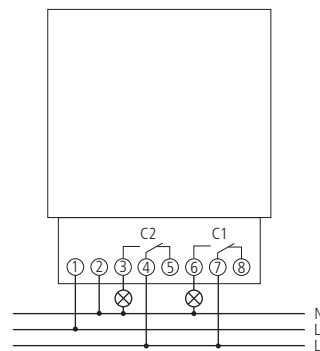

TR 684-2 top2

## Time and light control

### Digital time switches, Front panel installation/wall installation

2



theRolla S031

theRolla P032

#### Description

##### Common functions

- Digital time switch for drive control of roller blinds and blinds
- Integrated buttons for manual control (Up/Down/Stop button)
- Slide switch for setting the operating mode (Manual/Auto)
- Programming of intermediate position and ventilation position
- Blocking time (prevents the roller blinds from moving up or down too early, due to the Astro function)
- Holiday program (presence simulation)
- Astro position selectable by city list or coordinates (longitude/latitude)
- Text-based user guidance in the display
- Automatic summer-winter time changeover
- Removable control panel
- Replaceable battery (type CR 2032)

##### theRolla S031

- „Astro evening“ program - opens roller blinds and blinds according to a programmed switching time and closes them automatically at sunset via Astro command
- „Individual switching times“ program - opens and closes roller blinds and blinds according to a programmed switching time
- Times programmable for two fixed blocks (Monday-Friday, Saturday-Sunday)

##### theRolla P032

- Comfort time switch
- „Astro“ program - opens and closes roller blinds and blinds at sunrise and sunset times (Astro times).
- „Astro evening“ program - opens roller blinds and blinds according to a programmed switching time and closes them automatically at sunset via Astro command
- „Individual switching times“ program - opens and closes roller blinds and blinds according to programmed switching times
- Additional second special program
- Times individually programmable for each weekday
- Times programmable for two fixed blocks (Monday-Friday, Saturday-Sunday)
- Times programmable for one fixed block (Monday-Sunday)
- Connection of an optional light sensor (sun protection/dimming function)

#### Product selection

Program	External light sensor connectable	Comfort functions	Type	Article number
Weekly program, Astronomical program	–	–	theRolla S031	0310100
	✓	✓	theRolla P032	0320100

### Technical data

	theRolla S031	theRolla P032
Operating voltage	230–240 V AC	
Frequency	50–60 Hz	
Installation type	Wall installation	
Switching capacity at 250 V AC, $\cos \varphi = 1$	5 A	
Type of protection	IP 20	
Protection class	II	
Battery	1 x CR 2032	
Type of contact	2 x NO contact	
Ambient temperature	0 °C ... +55 °C	

### Accessories



**Light sensor theRolla**  
for theRolla P032  
↳ Art.No.: 9070926  
Details page 334

### Scale drawings

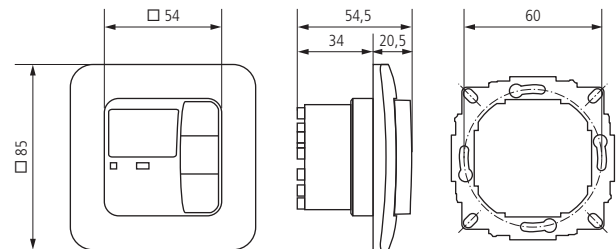

### Connection diagrams

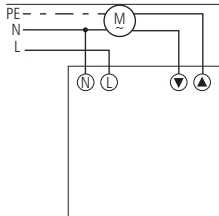

theRolla S031

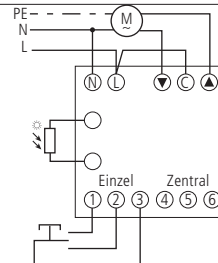

theRolla P032

# Time and light control

## Digital time switches, Plug-in

2



theben-eltimo 020 S

theben-eltimo 020 S DCF

### Description

#### Common functions

- Digital plug-in timer with weekly program
- Use with earthed sockets
- 1 channel
- Easy operation via keys for program function and day of the week, hours, minutes

- ON-OFF switching times
- Switching preselection
- Permanent switching ON/OFF
- Random program
- Automatic summer / winter time changeover

theben-eltimo 020 S

- 36 memory locations

theben-eltimo 020 S DCF

- DCF radio control
- 33 memory locations

### Product selection

Program	Number of channels	Memory locations	Time basis	Operating voltage	Type	Article number
Weekly program	1	36	Quartz	230 V AC	theben-eltimo 020 S	0200000
		33	Quartz/DCF77	230 V AC	theben-eltimo 020 S DCF	0200300

### Technical data

	theben-eltimo 020 S	theben-eltimo 020 S DCF
Operating voltage	230 V AC	
Frequency	50 Hz	
Installation type	Plug-in	
Type of contact	NO contact	
Power reserve	20 days	
Switching capacity at 250 V AC, cos φ = 1	16 A	
Switching capacity at 250 V AC, cos φ = 0,6	2 A	
Incandescent/halogen lamp load 230 V	1000 W	
Shortest switching times	1 min	
Time accuracy at 25 °C	≤ ± 1 s/day (quartz)	DCF77 synchronous or ≤ ± 1 s/day (quartz)
Stand-by consumption	0,8 W	
Type of protection	IP 20	
Protection class	II for housing, I for plug system as per EN 62 730-1	
Ambient temperature	-10 °C ... +40 °C	

### Scale drawings

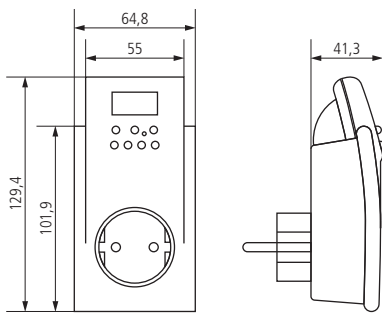

theben-eltimo 020 S, theben-eltimo 020 S DCF



## A special form of stability

Stability is a precondition for innovative power, Theben offers both. Everyone benefits, our customers, our partners and our employees. Because only those with the required resource can invest in innovation, but also the solid foundations of a company create climate of trust. This kind of predictability has characterised Theben's success for many years. Behind that lies a local virtue, one that is of special importance in times like these, solidarity.

# Time and light control

## Analogue time switches

	Program	Number of channels	Type of contact	Power reserve	Shortest switching times	Programmable every	Type of connection	Type	Page
--	---------	--------------------	-----------------	---------------	--------------------------	--------------------	--------------------	------	------

### DIN rail, 1 module

	Daily program	1	NO contact	–	15 min	15 min	Screw terminals	SYN 160 a	48
				3 days	15 min	15 min	Screw terminals	SUL 180 a	48
	Weekly program	1	NO contact	3 days	2 h	2 h	Screw terminals	MEM 190 a	48

### DIN rail, 3 modules

	60 minutes program	1	Changeover contact	–	37,5 s	37,5 s	DuoFix spring terminals	SYN 151 h	50
	Daily program	1	Changeover contact	–	15 min	15 min	DuoFix spring terminals	SYN 161 d	50
				200 hours	15 min	15 min	DuoFix spring terminals	SUL 181 d	50
Weekly program	1	Changeover contact	200 hours	2 h	2 h	DuoFix spring terminals	SUL 191w	50	
	Daily program	2	Changeover contact	3 days	30 min	15 min	Screw terminals	SUL 188 g	52
	Daily/weekly program with 1/2 day OFF function	1	Changeover contact	3 days	45 min, 12 h	15 min, 12 h	Screw terminals	SUL 188 hw	52

### Front panel installation/wall installation

	Daily program	1	Changeover contact	–	15 min	15 min	Screw terminals	SYN 169 s	54
				3 days	15 min	15 min	Screw terminals	SUL 189 s	54
	Daily program	1	Changeover contact	–	20 min, 2 h	5 min, 30 min	Screw terminals	SYN 269 h	56
				3 days	20 min, 2 h	5 min, 30 min	Screw terminals	SUL 289 h	56
		2	Changeover contact	3 days	20 min, 2 h	5 min, 30 min	Screw terminals	SUL 289 g	56
	60 minutes program	1	Changeover contact	–	1,25 min	18,5 s	Screw terminals	TM 179 h	58
	Daily/weekly program with 1/2 day OFF function	1	Changeover contact	3 days	30 min, 12 h	15 min, 12 h	Screw terminals	SUL 189 hw	58

### Wall installation/3-point mounting

	Daily program	2	Changeover contact	6 days	20 min	5 min	Screw terminals	SUL 285/2 T	60
-------------------------------------------------------------------------------------	---------------	---	--------------------	--------	--------	-------	-----------------	-------------	----

### Plug-in

	Daily program	1	NO contact	–	15 min	15 min	Plug-in	theben-timer 26	61
								theben-timer 26 IP 44	61
	Weekly program	1	NO contact	–	2 h	2 h	Plug-in	theben-timer 27	61

### Surface-mounted

	Daily and defrost program	2	Changeover contact	–	2 min, 1 h	1 min, 1 h	Screw terminals	FRI 77 g	62
-------------------------------------------------------------------------------------	---------------------------	---	--------------------	---	------------	------------	-----------------	----------	----

### Drive with quick fastening for DIN rail

	Daily and defrost program	1	Changeover contact	–	2 min, 1 h	1 min, 1 h	Screw terminals	FRI 77 h-2	62
		2	Changeover contact	–	2 min, 1 h	1 min, 1 h	Screw terminals	FRI 77 g-2	62

# Time and light control

## Analogue time switches, DIN rail, 1 module

3



### Description

- |                                                                                                                                                                                                                                        |                                                                                                                                                                                                                               |
|----------------------------------------------------------------------------------------------------------------------------------------------------------------------------------------------------------------------------------------|-------------------------------------------------------------------------------------------------------------------------------------------------------------------------------------------------------------------------------|
| <p>Common functions</p> <ul style="list-style-type: none"> <li>- Analogue time switch</li> <li>- 1 channel</li> <li>- Screw terminals</li> <li>- Manual switch with 3 positions: Permanent ON/AUTO/continuous OFF</li> </ul>           | <p>SUL 180 a</p> <ul style="list-style-type: none"> <li>- Daily program</li> <li>- With power reserve</li> <li>- 96 switching segments</li> <li>- Quartz controlled</li> <li>- Shortest switching time: 15 minutes</li> </ul> |
| <p>SYN 160 a</p> <ul style="list-style-type: none"> <li>- Daily program</li> <li>- Without power reserve</li> <li>- 96 switching segments</li> <li>- Synchronised with mains</li> <li>- Shortest switching time: 15 minutes</li> </ul> | <p>MEM 190 a</p> <ul style="list-style-type: none"> <li>- Weekly program</li> <li>- With power reserve</li> <li>- 84 switching segments</li> <li>- Quartz controlled</li> <li>- Shortest switching time: 2 hours</li> </ul>   |

### Product selection

Program	Number of channels	Power reserve	Shortest switching times	Programmable every	Type of contact	Operating voltage	Type	Article number
Daily program	1	-	15 min	15 min	NO contact	230 V AC	SYN 160 a	1600001
		3 days	15 min	15 min	NO contact	230–240 V AC	SUL 180 a	1800001
Weekly program	1	3 days	2 h	2 h	NO contact	230–240 V AC	MEM 190 a	1900001

# Time and light control

## Analogue time switches, DIN rail, 1 module

3

### Technical data

	SYN 160 a	SUL 180 a	MEM 190 a
Operating voltage	230 V AC	230 – 240 V AC	
Frequency	50 Hz	50 – 60 Hz	
Width	1 module		
Installation type	DIN rail		
Program	Daily program		Weekly program
Power reserve	–	3 days	
Switching capacity at 250 V AC, cos φ = 1	16 A		
Switching capacity at 250 V AC, cos φ = 0,6	4 A		
Incandescent / halogen lamp load	1000 W		
Energy saving lamps	150 W		
LED lamp < 2 W	30 W		
LED lamp 2-8 W	90 W		
LED lamp > 8 W	100 W		
Shortest switching times	15 min		2 h
Programmable every	15 min		2 h
Time accuracy at 25 °C	Synchronised with mains	≤ ± 1 s / day (quartz)	
Stand-by consumption	0,9 W	0,5 W	
Test approval	VDE		
Type of protection	IP 20		
Protection class	II according to EN 60 730-1		
Ambient temperature	-25 °C ... +50 °C	-10 °C ... +50 °C	

### Accessories



**Front panel kit**  
↳ Art.No.: 9070001  
Details page 334



**Wall mounting kit 17,5 mm**  
↳ Art.No.: 9070065  
Details page 334

### Connection diagrams

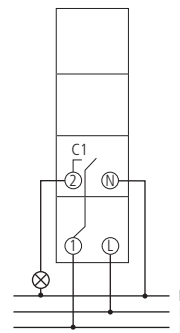

SYN 160 a, SUL 180 a, MEM 190 a

# Time and light control

## Analogue time switches, DIN rail, 3 modules

3



SYN 151 h

SUL 181 d

SUL 191 w

### Description

#### Common functions

- Analogue time switch
- 1 channel
- DuoFix spring terminals
- Switching preselection
- Manual switch with 3 positions: Continuous ON/AUTO/continuous OFF
- Switching status display

#### SYN 151 h

- 60 minute program
- Without power reserve
- 96 switching segments
- Synchronised with mains
- Shortest switching time: 37.5 seconds

#### SYN 161 d

- Daily program
- Without power reserve
- 96 switching segments
- Synchronised with mains
- Shortest switching time: 15 minutes
- Clock hands for time display and in addition 12/24 hour recognition
- Simple summer/winter time correction

#### SUL 181 d

- Daily program
- With power reserve (NiMH rechargeable battery)
- 96 switching segments

- Quartz controlled
- Shortest switching time: 15 minutes
- Clock hands for time display and in addition 12/24 hour recognition
- Simple summer/winter time correction

#### SUL 191 w

- Weekly program
- With power reserve (NiMH rechargeable battery)
- 84 switching segments
- Quartz controlled
- Shortest switching time: 2 hours
- Clock hands for time display and in addition 12/24 hour recognition
- Simple summer/winter time correction

### Product selection

Program	Number of channels	Power reserve	Shortest switching time	Programmable every	Type of contact	Operating voltage	Type	Article number
60 minutes program	1	-	37,5 s	37,5 s	Changeover contact	230 V AC	SYN 151 h	1510011
Daily program	1	-	15 min	15 min	Changeover contact	230 V AC	SYN 161 d	1610011
			15 min	15 min	Changeover contact	110-230 V AC	SUL 181 d	1810011
					Changeover contact	12-24 V UC	SUL 181 d 24V	1814011
Weekly program	1	200 h	2 h	2 h	Changeover contact	110-230 V AC	SUL 191 w	1910011

# Time and light control

## Analogue time switches, DIN rail, 3 modules

3

### Technical data

	SYN 151 h	SYN 161 d	SUL 181 d	SUL 191 w	SUL 181 d 24V
Operating voltage	230 V AC		110–230 V AC		12–24 V UC
Frequency	50 Hz		50–60 Hz		
Width	3 modules				
Installation type	DIN rail				
Program	60 minutes program	Daily program		Weekly program	Daily program
Power reserve	–		200 hours, approx. 100 hours at 110 V		200 hours
Switching capacity at 250 V AC, $\cos \varphi = 1$	10 A	16 A			
Switching capacity at 250 V AC, $\cos \varphi = 0,6$	4 A				
Incandescent/halogen lamp load	1100 W				
LED lamp < 2 W	20 W				
LED lamp > 2 W	180 W				
Shortest switching time	37,5 s	15 min		2 h	15 min
Programmable every	37,5 s	15 min		2 h	15 min
Time accuracy at 25 °C	Synchronised with mains		$\leq \pm 1$ s/day (quartz)		
Stand-by consumption	0,9 W	0,5 W			
Test approval					–
Type of protection	IP 20				
Protection class	II according to EN 60 730-1				
Ambient temperature	–20 °C ... +55 °C				

### Accessories



Wall mounting kit 52,5 mm  
↳ Art.No.: 9070050  
Details page 334



Front panel kit  
↳ Art.No.: 9070001  
Details page 334

### Connection diagrams

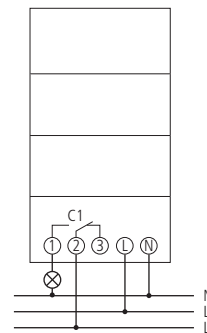

SYN 151 h, SYN 161 d,  
SUL 181 d, SUL 191 w

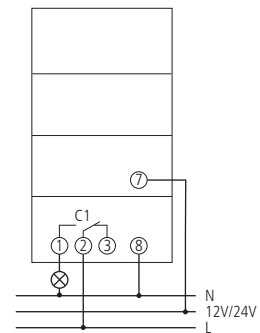

SUL 181 d 24V

# Time and light control

## Analogue time switches, DIN rail, 3 modules

3



SUL 188 g

SUL 188 hw

### Description

#### Common functions

- Analogue time switch
- With power reserve (NiMH rechargeable battery)
- Quartz controlled
- Tappets
- Screw terminals
- Switching status display
- Operating indication

#### SUL 188 g

- Daily program
- 2 channels
- Fine adjustment to set the time to the minute
- Shortest switching time: 30 minutes
- 10 tappets included in delivery

#### SUL 188 hw

- Daily/weekly program and 1/2 day OFF function for the weekdays
- 1 channel (with series connection of the 2 contacts)
- Tappets and turning segments
- Shortest switching time: 45 minutes (12 hours for the 1/2 day OFF function)
- 6 tappets included in delivery

### Product selection

Program	Number of channels	Power reserve	Shortest switching times	Programmable every	Type of contact	Operating voltage	Type	Article number
Daily program	2	3 days	30 min	15 min	Changeover contact	230 V AC	SUL 188 g	1880033
Daily/weekly program with 1/2 day OFF function	1	3 days	45 min, 12 h	15 min, 12 h	Changeover contact	230 V AC	SUL 188 hw	1880108

# Time and light control

## Analogue time switches, DIN rail, 3 modules

3

### Technical data

	SUL 188 g	SUL 188 hw
Operating voltage	230 V AC	
Frequency	45–60 Hz	
Width	3 modules	
Installation type	DIN rail	
Program	Daily program	Daily/weekly program with 1/2 day OFF function
Power reserve	3 days	
Switching capacity at 250 V AC, $\cos \varphi = 1$	10 A	
Switching capacity at 250 V AC, $\cos \varphi = 0,6$	4 A	
Shortest switching times	30 min	45 min, 12 h
Programmable every	15 min	15 min, 12 h
Time accuracy at 25 °C	$\leq \pm 1$ s/day (quartz)	
Stand-by consumption	0,5 W	
Test approval	VDE	
Type of protection	IP 20	
Protection class	II according to EN 60 730-1	
Ambient temperature	-20 °C ... +55 °C	

### Accessories



#### Front panel kit

↳ Art.No.: 9070001  
Details page 334



#### Terminal cover 52,5 mm

↳ Art.No.: 9070061  
Details page 334

### Connection diagrams

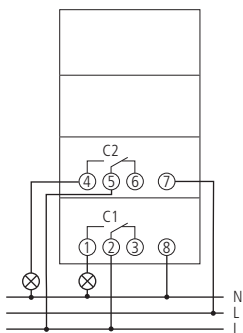

SUL 188 g

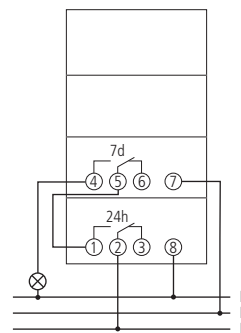

SUL 188 hw

## Time and light control

### Analogue time switches, Front panel installation/wall installation

3



SYN 169 s

SUL 189 s

#### Description

##### Common functions

- Analogue time switch
- 1 channel
- Daily program
- 96 switching segments
- Shortest switching time: 15 minutes
- Clock hands for time display
- Switching preselection
- Permanent ON/OFF switch
- Switching status display
- Simple summer/winter time correction

##### SYN 169 s

- Without power reserve
- Synchronised with mains

##### SUL 189 s

- With power reserve (NiMH rechargeable battery)
- Quartz controlled

#### Product selection

Program	Number of channels	Power reserve	Shortest switching times	Programmable every	Type of contact	Operating voltage	Type	Article number
Daily program	1	-	15 min	15 min	Changeover contact	230 V AC	SYN 169 s	1690801
		3 days	15 min	15 min	Changeover contact	230 V AC	SUL 189 s	1890801
						110 V AC	SUL 189 s 110V	1891801

# Time and light control

## Analogue time switches, Front panel installation/wall installation

3

### Technical data

	SYN 169 s	SUL 189 s	SUL 189 s 110V
Operating voltage	230 V AC		110 V AC
Frequency	50 Hz	50–60 Hz	
Installation type	Front panel installation/wall installation		
Program	Daily program		
Power reserve	–	3 days, full power reserve approx. 3 days after connection to operating voltage	
Switching capacity at 250 V AC, $\cos \varphi = 1$	10 A		
Switching capacity at 250 V AC, $\cos \varphi = 0,6$	2 A		
Shortest switching times	15 min		
Programmable every	15 min		
Time accuracy at 25 °C	Synchronised with mains	$\leq \pm 1$ s/day (quartz)	
Stand-by consumption	0,9 W	0,5 W	
Test approval	EMV		–
Type of protection	IP 20		
Protection class	II according to EN 60 730-1		
Ambient temperature	-10 °C ... +55 °C		

### Accessories



Snap-on mounting 72 x 72

↳ Art.No.: 9070071

Details page 334

### Scale drawings

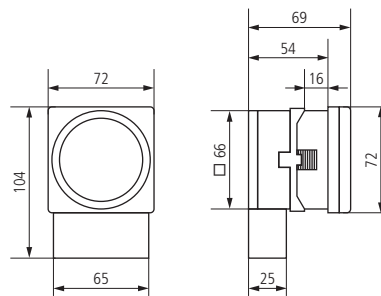

SYN 169 s, SUL 189 s

### Connection diagrams

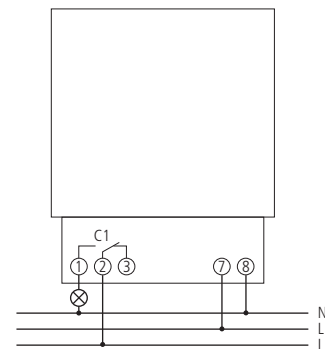

SYN 169 s, SUL 189 s

## Time and light control

### Analogue time switches, Front panel installation/wall installation

3



SYN 269 h

SUL 289 g

#### Description

##### Common functions

- Analogue time switch with daily or weekly program (switching disc can be turned)
- Tappets
- Shortest switching time: 20 minutes or 2 hours
- Clock hands for time display
- Switching status display

##### SYN 269 h

- 1 channel
- Without power reserve
- Synchronised with mains
- Switching preselection
- Permanent ON/OFF switch
- Simple summer/winter time correction
- 32 tappets included in delivery

##### SUL 289 h

- 1 channel
- With power reserve (NiMH rechargeable battery)
- Quartz controlled
- Switching preselection
- Permanent ON/OFF switch
- Simple summer/winter time correction
- 32 tappets included in delivery

##### SUL 289 g

- 2 channels
- With power reserve (NiMH rechargeable battery)
- Quartz controlled
- 49 tappets included in delivery

#### Product selection

Program	Number of channels	Power reserve	Shortest switching times	Programmable every	Type of contact	Operating voltage	Type	Article number
Daily program	1	-	20 min, 2 h	5 min, 30 min	Changeover contact	230 V AC	SYN 269 h	2690008
		3 days	20 min, 2 h	5 min, 30 min	Changeover contact	230 V AC	SUL 289 h	2890008
	2	3 days	20 min, 2 h	5 min, 30 min	Changeover contact	230 V AC	SUL 289 g	2890033

# Time and light control

## Analogue time switches, Front panel installation/wall installation

3

### Technical data

	SYN 269 h	SUL 289 h	SUL 289 g
Operating voltage	230 V AC		
Frequency	50 Hz	50–60 Hz	
Installation type	Front panel installation/wall installation		
Program	Daily program, Weekly program		
Power reserve	–	3 days, full power reserve approx. 3 days after connection to operating voltage	
Switching capacity at 250 V AC, $\cos \varphi = 1$	10 A		
Switching capacity at 250 V AC, $\cos \varphi = 0,6$	2 A		
Shortest switching times	20 min, 2 h		
Programmable every	5 min, 30 min		
Time accuracy at 25 °C	Synchronised with mains	$\leq \pm 1$ s/day (quartz)	
Stand-by consumption	0,9 W	0,5 W	
Type of protection	IP 20		
Protection class	II according to EN 60 730-1		
Ambient temperature	-10 °C ... +55 °C		

### Accessories



Snap-on mounting 72 x 72  
 ↳ Art.No.: 9070071  
 Details page 334

### Scale drawings

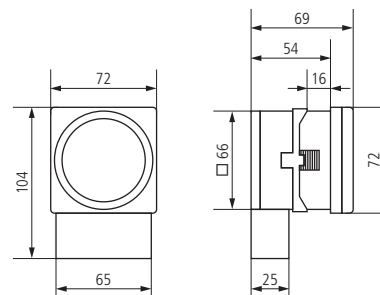

### Connection diagrams

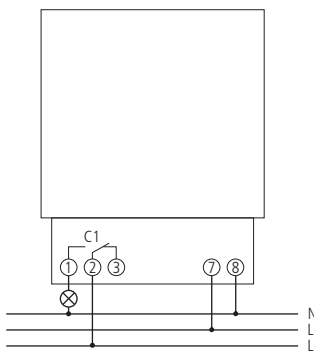

SYN 269 h, SUL 289 h

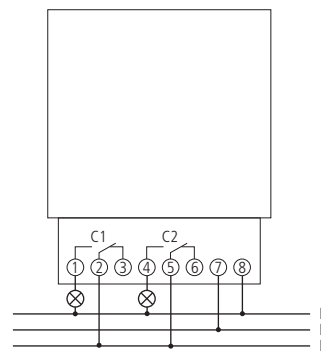

SUL 289 g

## Time and light control

### Analogue time switches, Front panel installation/wall installation

3



TM 179 h

SUL 189 hw

#### Description

##### Common functions

- Analogue time switch
- Switching status display
- 6 tappets included in delivery

##### TM 179 h

- 60 minute program
- 1 channel

- Without power reserve
- Synchronised with mains
- Tappets
- Shortest switching time: 75 seconds
- Switching preselection

##### SUL 189 hw

- Daily/weekly program and 1/2 day OFF function for the weekdays

- 1 channel (with series connection of 2 the contacts)
- With power reserve (NiMH rechargeable battery)
- Quartz controlled
- Tappets and turning segments
- Shortest switching time: 30 minutes (12 hours for the 1/2 day OFF function)

#### Product selection

Program	Number of channels	Power reserve	Shortest switching times	Programmable every	Type of contact	Operating voltage	Type	Article number
60 minutes program	1	-	1,25 min	18,5 s	Changeover contact	230 V AC	TM 179 h	1790008
Daily/weekly program with 1/2 day OFF function	1	3 days	30 min, 12 h	15 min, 12 h	Changeover contact	230 V AC	SUL 189 hw	1890108

# Time and light control

## Analogue time switches, Front panel installation/wall installation

3

### Technical data

	TM 179 h	SUL 189 hw
Operating voltage	230 V AC	
Frequency	50 Hz	50–60 Hz
Installation type	Front panel installation/wall installation	
Program	60 minutes program	Daily/weekly program with 1/2 day OFF function
Power reserve	–	3 days, full power reserve approx. 3 days after connection to operating voltage
Switching capacity at 250 V AC, $\cos \varphi = 1$	10 A	
Switching capacity at 250 V AC, $\cos \varphi = 0,6$	2 A	
Shortest switching times	1,25 min	30 min, 12 h
Programmable every	18,5 s	15 min, 12 h
Time accuracy at 25 °C	Synchronised with mains	$\leq \pm 1$ s/day (quartz)
Stand-by consumption	0,9 W	0,5 W
Test approval	EMV	
Type of protection	IP 20	
Protection class	II according to EN 60 730-1	
Ambient temperature	-10 °C ... +55 °C	

### Accessories



Snap-on mounting 72 x 72

↳ Art.No.: 9070071

Details page 334

### Scale drawings

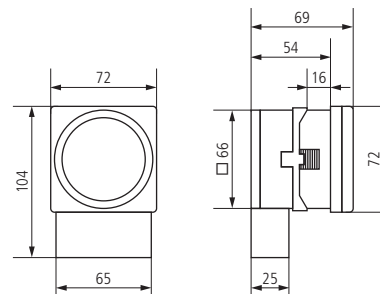

### Connection diagrams

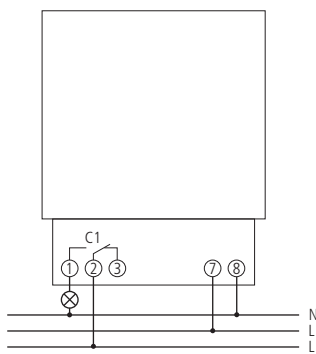

TM 179 h

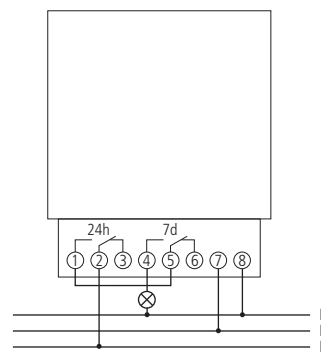

SUL 189 hw

# Time and light control

## Analogue time switches, Wall installation/3-point mounting

3



SUL 285/2 T

### Description

- Analogue tariff time switch with daily program
- 2 channels
- With power reserve (exchangeable NiMH rechargeable battery)
- Quartz controlled
- Tappets
- Shortest switching time: 20 minutes
- Clock hands for time display
- Switching status display
- Simple summer/winter time correction
- Control LED for battery change
- 32 tappets included in delivery

### Product selection

Program	Number of channels	Power reserve	Shortest switching times	Programmable every	Type of contact	Operating voltage	Type	Article number
Daily program	2	6 days	20 min	5 min	Changeover contact	110–230 V AC	SUL 285/2 T	2850033

### Technical data

SUL 285/2 T			
Operating voltage	110–230 V AC	Shortest switching times	20 min
Frequency	50–60 Hz	Programmable every	5 min
Installation type	Wall installation/3-point mounting	Time accuracy at 25 °C	± 1 s/day (quartz)
Program	Daily program	Stand-by consumption	0,6 W
Power reserve	6 days, full power reserve approx. 3 days after connection to operating voltage	Type of protection	IP 54
Switching capacity at 250 V AC, cos φ = 1	6 A	Protection class	II according to EN 62 054-21
Switching capacity at 250 V AC, cos φ = 0,6	2 A	Ambient temperature	-10 °C ... +55 °C

### Scale drawings

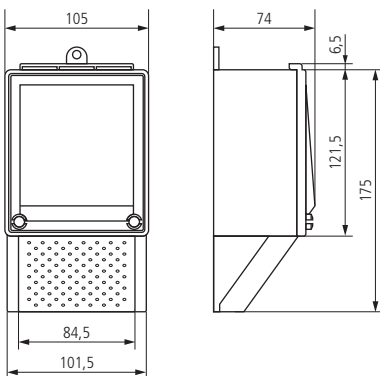

SUL 285/2 T

### Connection diagrams

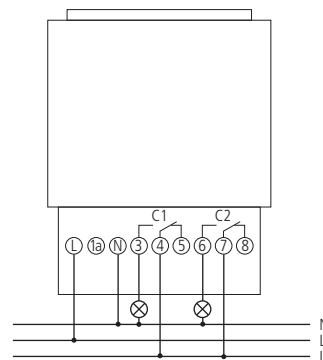

SUL 285/2 T



## Description

### Common functions

- Analogue plug-in timer
- 1 channel
- Without power reserve
- Synchronised with mains
- Use with earthed sockets
- Switching preselection
- Switching status display

### theben-timer 26

- Daily program
- 96 switching segments
- Shortest switching time: 15 minutes

### theben-timer 26 IP 44

- As theben-timer 26, but:
- Waterproof protection for damp locations and outdoor areas

### theben-timer 27

- Transparent cover
- Weekly program
- 84 switching segments
- Shortest switching time: 2 hours

\* According to guarantee conditions, see [www.theben.de/en/guarantee](http://www.theben.de/en/guarantee)

## Product selection

Program	Shortest switching times	Programmable every	Type of contact	Operating voltage	Type	Article number
Daily program	15 min	15 min	NO contact	230 V AC	theben-timer 26	0260030
				230 V AC	theben-timer 26 IP 44	0260855
Weekly program	2 h	2 h	NO contact	230 V AC	theben-timer 27	0270930

## Technical data

	theben-timer 26	theben-timer 26 IP 44	theben-timer 27
Operating voltage	230 V AC		
Frequency	50 Hz		
Installation type	Plug-in		
Program	Daily program		Weekly program
Switching capacity at 250 V AC, $\cos \varphi = 1$	16 A		
Switching capacity at 250 V AC, $\cos \varphi = 0,6$	4 A		
Shortest switching times	15 min		2 h
Programmable every	15 min		2 h
Time accuracy at 25 °C	Synchronised with mains		
Stand-by consumption	0,8 W		
Test approval		-	
Type of protection	IP 20	IP 44	IP 20
Protection class	II according to EN 60 730-1		
Ambient temperature	-40 °C ... +55 °C		

## Time and light control

Analogue time switches, Surface-mounted, Drive with quick fastening for DIN rail

3

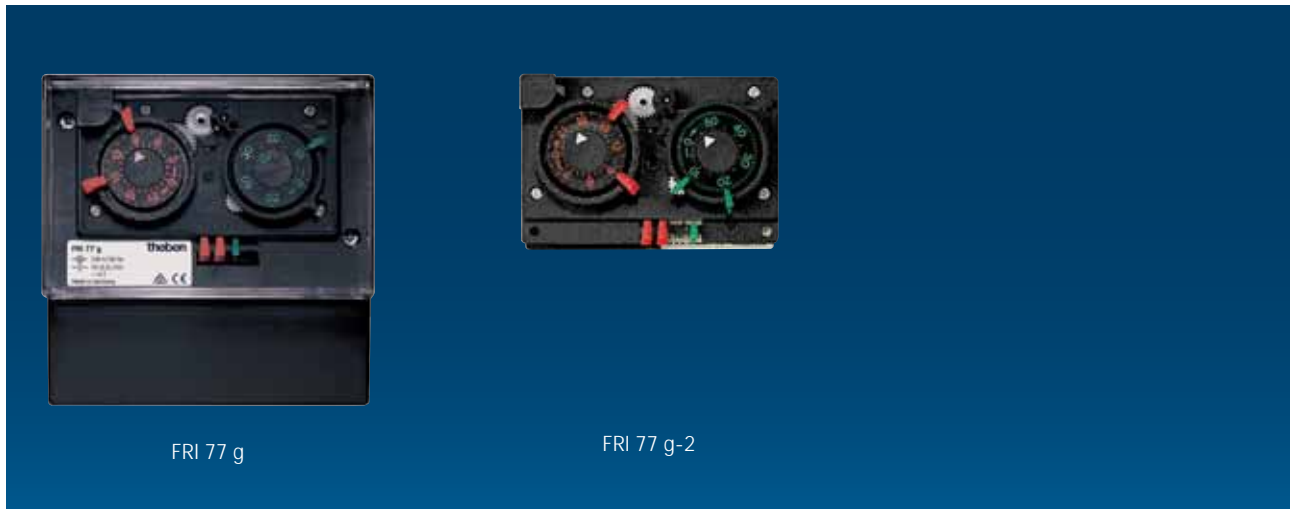

FRI 77 g

FRI 77 g-2

### Description

#### Common functions

- Analogue cooling time switch with daily and short time program
- Tappet
- 2 separate switching discs

#### FRI 77 g

- 2 channels
- Wall-mounted
- 8 tappets included in delivery
- Optional delayed switching on of fan

#### FRI 77 h-2

- 1 channel
- Drive with quick fastening for DIN rail
- 6 tappets included in delivery

#### FRI 77 g-2

- 2 channels
- Drive with quick fastening for DIN rail
- 8 tappets included in delivery
- Optional delayed switching on of fan

### Product selection

Type of contact	Installation type	Shortest switching times	Programmable every	Operating voltage	Type	Article number
Changeover contact	Surface-mounted	2 min, 1 h	1 min, 1 h	230 V AC	FRI 77 g	0770033
	Drive with quick fastening for DIN rail	2 min, 1 h	1 min, 1 h	230 V AC	FRI 77 h-2	0770802
					FRI 77 g-2	0770832

Analogue time switches, Surface-mounted, Drive with quick fastening for DIN rail

Technical data

	FRI 77 g	FRI 77 h-2	FRI 77 g-2
Operating voltage	230 V AC		
Frequency	50 Hz		
Installation type	Surface-mounted	Drive with quick fastening for DIN rail	
Program	Daily and defrost program		
Switching capacity at 250 V AC, $\cos \varphi = 1$	16 A		
Switching capacity at 250 V AC, $\cos \varphi = 0,6$	2,5 A		
Shortest switching times	2 min, 1 h		
Programmable every	1 min, 1 h		
Time accuracy at 25 °C	Synchronised with mains		
Stand-by consumption	0,9 W		
Type of protection	IP 20	IP 00	
Protection class	II according to EN 60 730-1		
Ambient temperature	-10 °C ... +50 °C		

Scale drawings

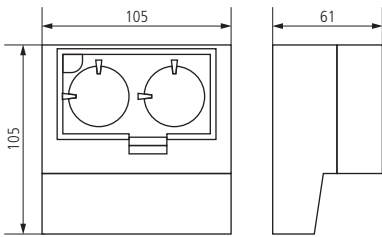

FRI 77 g

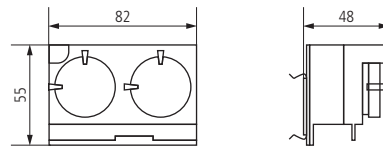

FRI 77 h-2, FRI 77 g-2

Connection diagrams

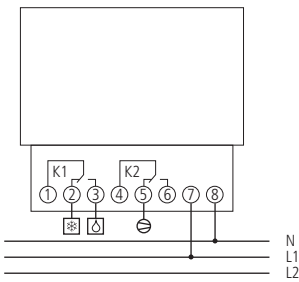

FRI 77 g, FRI 77 g-2

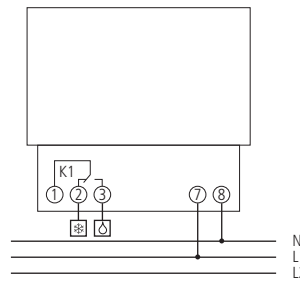

FRI 77 h-2



## Precise in effect

Precision is a value in itself. It defines itself via what you want to achieve. Theben is always aiming to increase its efficiency. So that more can be achieved with less energy being used. Saving energy is one thing, boosting comfort another. The better we achieve both, the higher our efficiency.



Description	Type	Page
-------------	------	------

### Time relays

 Multi-function relay	TM 345 M	66
 Time relay with switch function	TM 345 B	66

Installation type	Size front plate	Type	Page
-------------------	------------------	------	------

### Hour counters, analogue

 Front panel installation	48 x 48 mm	BZ 142-1	68
		BZ 142-3	68
	52 x 52 mm	BZ 143-1	68
 DIN rail	35 x 45 mm	BZ 145	68

### Hour counters, digital

 Front panel installation	24 x 48 mm	BZ 146	70
	48 x 48 mm	BZ 147	70
 DIN rail	35 x 45 mm	BZ 148	70

# Time and light control

## Time relays

4

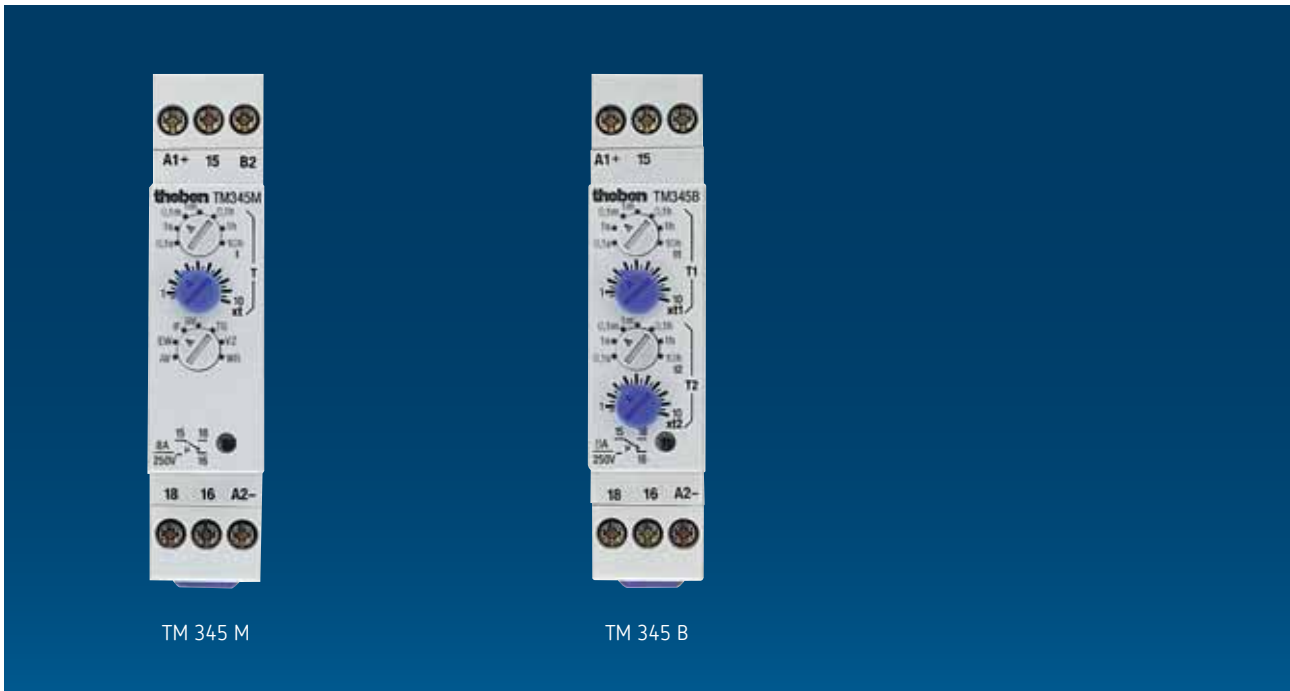

TM 345 M

TM 345 B

### Description

#### Common functions

- Electronic time relay
- Can be used universally for controlling automatic processes in machines, lighting, ventilation, heating, cupboards etc.
- Precise analogue time setting
- Multi-voltage input for all supply and control voltages, no jumpers or additional terminals are required
- LED to display the switching status

#### TM 345 M

- Locking snap switch to select the period of time, as well as the following operating modes:
- Response delay (AV), without control contact
- Wipe contact (EW), without control contact
- Release delay (RV), with control contact
- Pulse former (IF), with control contact

- Response and release delay (VZ), with control contact
- Pulse output (WR), with control contact
- Flip-flop (TG)

#### TM 345 B

- With flip-flop function
- Pulse and break time independently adjustable

### Product selection

Multi-function	Type	Article number
✓	TM 345 M	3450731
-	TM 345 B	3450730

### Technical data

	TM 345 M	TM 345 B
Operating voltage	12 – 240 V AC/DC	24 – 240 V AC / 24 V DC
Frequency	50 – 60 Hz	
Width	1 module	
Stand-by consumption	1 W	
Type of contact	Changeover contact	
Housing and insulation material	High-temperature resistant, self-extinguishing thermoplastic	
Switching capacity at 250 V AC, $\cos \varphi = 1$	8 A	
Switching output	Potential-free	
Nominal current	10 mA – 20 A < 10 ms	
Electrical service life	10 <sup>5</sup> operating cycles	
Fall back value of nominal input voltage	< 10.2 V AC/DC (as per EN 61812-1)	< 20.4 V AC/DC (as per EN 61812-1)
Type of protection	IP 20	
Protection class	II	
Ambient temperature	-20 °C ... +60 °C	

### Accessories



#### Wall mounting kit 35 mm

for BZ 145

↳ Art.No.: 9070064

Details page 334

### Connection diagrams

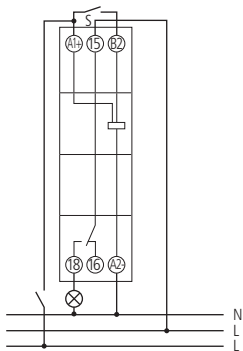

TM 345 M

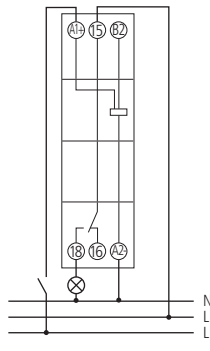

TM 345 M

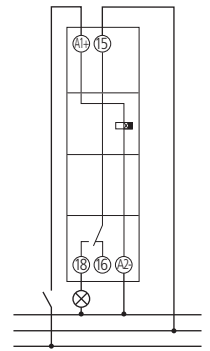

TM 345 B

## Time and light control

### Hour counters, analogue, front panel and DIN rail

4



#### Description

##### Common functions

- Hour counter with synchronous motor drive

##### BZ 142-1/143-1

- Front panel devices with click-in or stretch clamp supports for walls up to a maximum of 10 mm thick
- Clamp or flat plug connection 6.3 mm
- Versions for direct voltage with quartz-controlled stepper motor
- Progress display

##### BZ 142-3

- With plug-in base for wall installation (terminal cover required)

- Plug-in base with quick fastening for 35 mm profile rails (DIN EN 60 715)
- Screw terminals
- Contact protection to comply with accident prevention regulation BGV A3
- Housing colour: anthracite
- Versions for direct voltage with quartz-controlled stepper motor
- Progress display

##### BZ 145

- Built in distributor device with quick fastening for 35 mm profile rails (DIN EN 60 715)

- Top mounting with additional terminal box cover plate, sealable
- Control panel installation with assembly kit No. 907 0 001
- Contact protection to comply with accident prevention regulation BGV A3
- Captive screw terminals

#### Product selection

Counting range	Installation type	Size front plate	Size of Installation section	Operating voltage	Type	Article number
99 999,99 hours without reset	Front panel installation	48 x 48 mm	46 x 46 mm	230 V AC	BZ 142-1	1420721
				10-80 V DC	BZ 142-1 10V	1420821
				230-240 V AC	BZ 142-1 230V	1420621
				24 V AC	BZ 142-1 24V	1424721
				230 V AC	BZ 142-3	1420723
		52 x 52 mm	46 x 46 mm or ø 50 mm	10-80 V DC	BZ 142-3 10V	1420823
				230 V AC	BZ 143-1	1430721
				10-80 V DC	BZ 143-1 10V	1430821
				24 V AC	BZ 143-1 24V	1434721
				230 V AC	BZ 145	1450000
99 999,9 hours without reset	DIN rail	35 x 45 mm	35 x 45 mm (depth 60 mm)	230 V AC	BZ 145	1450000
				24-48 V DC	BZ 145 24V	1459024

### Technical data

	BZ 142-1	BZ 142-1 10V	BZ 142-1 230V	BZ 142-1 24V	BZ 142-3	BZ 142-3 10V	BZ 143-1	BZ 145	BZ 145 24V	
Operating voltage	230 V AC	10–80 V DC	230–240 V AC	24 V AC	230 V AC	10–80 V DC	230 V AC	230 V AC	24–48 V DC	
Frequency	50 Hz	–	60 Hz	50 Hz		–	50 Hz		–	
Width	–							2 modules		
Installation type	Front panel installation							DIN rail		
Counting range	99 999,99 hours without reset							99 999,9 hours without reset		
Type of protection	IP 65 (Front frame)							IP 20		
Protection class	II according to EN 60 335-1									
Ambient temperature	–20 °C ... +70 °C							–10 °C ... +70 °C		

### Accessories



**Clamp BZ**  
for BZ 142-1, BZ 143-1  
↳ Art.No.: 9070043  
Details page 336



**Cover 55 x 55 for BZ**  
for BZ 142-1  
↳ Art.No.: 9070041  
Details page 336



**Cover 72 x 72 for BZ**  
for BZ 142-1  
↳ Art.No.: 9070074  
Details page 336



**Plug-in socket BZ**  
for BZ 142-3  
↳ Art.No.: 9070042  
Details page 336



**Front kit BZ 142-3**  
for BZ 142-3  
↳ Art.No.: 9070075  
Details page 336



**Wall mounting kit 35 mm**  
for BZ 145  
↳ Art.No.: 9070064  
Details page 334

### Scale drawings

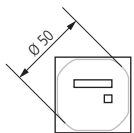

BZ 142-1

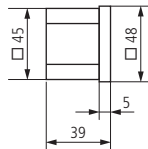

BZ 142-3

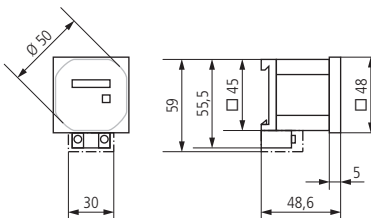

BZ 143-1

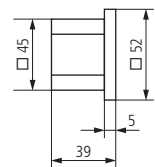

# Time and light control

## Hour counters, digital, front panel and DIN rail

4



### Description

#### Common functions

- Digital hour counter
- With EEPROM memory provides reliable operating data capture even with loss of power
- 7-digit high-contrast LCD display
- Onscreen progress display

#### BZ 146

- Installation cutout 22 mm x 45 mm
- Control panel installation
- Screw terminals
- Tension clamp brackets for walls up to 5mm thick
- Quartz controlled version

#### BZ 147

- Installation cutout 45 mm x 45 mm
- Control panel installation
- Screw terminals
- Tension clamp brackets for walls up to 5mm thick
- Quartz controlled version

#### BZ 148

- For DIN rail mounting with quick fastening for 35 mm profile rails (DIN EN 60 715)
- Surface mounting with additional terminal box cover plate option
- Captive screw terminals

### Product selection

Counting range	Installation type	Size front plate	Size of Installation section	Operating voltage	Type	Article number
99 999,99 hours without reset	Front panel installation	24 x 48 mm	22 x 45 mm	110–240 V AC	BZ 146	1460000
		48 x 48 mm	45 x 45 mm	110–240 V AC	BZ 147	1470000
999 999,9 hours without reset	DIN rail	35 x 45 mm	35 x 45 mm (depth 60 mm)	24–240 V AC / 12–150 V DC	BZ 148	1480000

### Technical data

	BZ 146	BZ 147	BZ 148
Operating voltage	110–240 V AC		24–240 V AC / 12–150 V DC
Frequency	50–60 Hz		
Width	–		2 modules
Installation type	Front panel installation		DIN rail
Counting range	99 999,99 hours without reset		999 999.9 hours without reset
Type of protection	IP 65		IP 20
Protection class	II according to EN 61010		
Ambient temperature	–30 °C ... +70 °C		–10 °C ... +70 °C

### Accessories



**Clamp BZ**  
for BZ 146, BZ 147  
↳ Art.No.: 9070043  
Details page 336



**Wall mounting kit 35 mm**  
for BZ 148  
↳ Art.No.: 9070064  
Details page 334

### Scale drawings

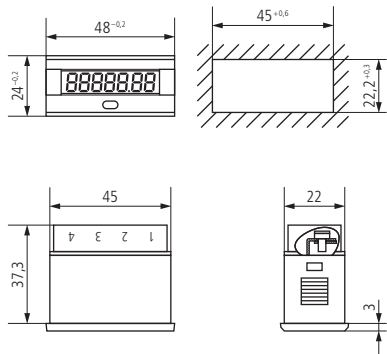

BZ 146

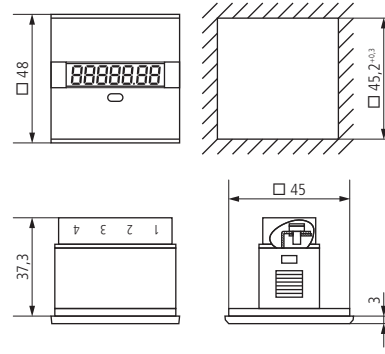

BZ 147

### Connection diagrams

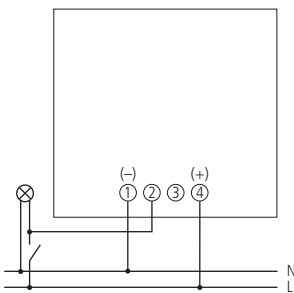

BZ 146, BZ 147

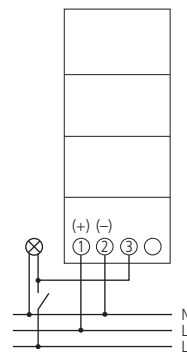

BZ 148



## Everything in view

When Paul Schwenk developed the first staircase time switch in 1921, it was due to his special kind of attentiveness. He noticed that the staircase light never switched off so lots of energy was being wasted. What then may have been no more than an expression of his frugality is now in demand worldwide as a consequence of climate change: using energy sensibly. Theben has been making a contribution to that for a long time now and not just with staircase light time switches. We call that attentiveness.

# Time and light control

## Staircase time switches/Dimmer

	Setting range time	Key input	Multi-voltage input	Switch-off pre-warning	Long-time function	Zero-cross switching	Without stand-by consumption	Type	Page
--	--------------------	-----------	---------------------	------------------------	--------------------	----------------------	------------------------------	------	------

### DIN rail, electronic with multi-function

	0,5–20 min	150 mA	✓	✓	60 min	✓	–	ELPA 1	74
			–	✓	60 min	✓	–	ELPA 6	74

### DIN rail, Electronic

	0,5–20 min	150 mA	✓	–	–	–	–	ELPA 3	74
			–	–	–	–	–	ELPA 7	74

### DIN rail, Electro-mechanical

	1–7 min	50 mA	–	–	–	–	✓	ELPA 8	76

### Flush-mounted, electronic with multi-function

	0,5–20 min	30 mA	✓	✓	60 min	✓	–	ELPA 041	78
-----------------------------------------------------------------------------------	------------	-------	---	---	--------	---	---	----------	----

### Flush-mounted, electronic with switch-off pre-warning

	0,5–20 min	30 mA	–	–	–	✓	–	ELPA 047	78
-------------------------------------------------------------------------------------	------------	-------	---	---	---	---	---	----------	----

	Universal dimmer for R, L, and C loads	Mounting type	Multi-voltage input	Multifunction	Operation via App possible	Type	Page
--	----------------------------------------	---------------	---------------------	---------------	----------------------------	------	------

### Dimmer

	✓	DIN rail	✓	–	–	DIMAX 532 plus	80
				✓	–	DIMAX 534 plus	80
	Flush-mounted		–	–	–	DIMAX 542 plus	82
				–	✓	DIMAX 544 plus	82

# Time and light control

## Staircase time switches, DIN rail, electronic

5



### Description

#### Common functions

- Staircase time switch, electronic
- Terminal layout same as ELPA 8
- Extremely accurate
- Push button input with electronic overload protection
- Automatic 3 or 4 conductor detection (4 conductor with connection for floor lighting, 3 conductor no longer permitted for new systems)

#### ELPA 1

- Zero-cross switching for relay-saving switching and high lamp loads
- Multi-functional device with 10 available functions, set at the front of the device
- Additional multi-voltage input electrically isolated for AC/DC 8...240 V, e.g. für intercoms
- Switch-off pre-warning (two double flashes) in accordance with DIN 18015-2 to avoid sudden darkness

- Extended function activated via long button press
- Immediate secondary switching (stair light switch) or prematurely switched off (pulse switch with switch-off delay)
- Permanent switch
- Electronic pulse light

#### ELPA 6

- Zero-cross switching for relay-saving switching and high lamp loads
- Multi-functional device with 10 available functions, set at the front of the device
- Switch-off pre-warning (two double flashes) in accordance with DIN 18015-2 to avoid sudden darkness
- Extended function activated via long button press
- Immediate secondary switching (stair light switch) or prematurely switched off (pulse switch with switch-off delay)
- Permanent switch
- Electronic pulse light

#### ELPA 6 plus

As ELPA 6 but:

- Switch-off pre-warning (two flashes) optimized for switching LEDs

#### ELPA 3

- Additional multi-voltage input electrically isolated for AC/DC 8...240 V, e.g. für intercoms
- Immediate secondary switching
- Toggle switch for permanent light

#### ELPA 7

As ELPA 3 but:

- Without multi-voltage input

### Product selection

Incandescent lamp load	Multi-function	Multi-voltage input	Switch-off pre-warning	Zero-cross switching	Type	Article number
3600 W	✓	✓	✓	✓	ELPA 1	0010002
		–	✓	✓	ELPA 6	0060002
		–	–	–	ELPA 6 plus	0060003
2300 W	–	✓	–	–	ELPA 3	0030002
		–	–	–	ELPA 7	0070002

### Technical data

	ELPA 1	ELPA 6	ELPA 6 plus	ELPA 3	ELPA 7
Operating voltage	220 – 240 V AC				
Frequency	50 – 60 Hz				
Stand-by consumption	0,9 W			0,7 W	
Glow lamp load	150 mA				
Setting range time	0,5 – 20 min				
3/4-way conductors	Automatic				
Type of contact	NO contact				
Switching output	Not potential-free (230 V)				
Incandescent / halogen lamp load	3600 W			2300 W	
Fluorescent lamp load (conventional) lead-lag circuit	3600 VA			2300 VA	
Fluorescent lamp load (conventional) parallel-corrected	1200 VA, 120 µF			400 VA, 42 µF	
Energy saving lamps	250 W			90 W	
LED lamp < 2 W	55 W			20 W	
LED lamp 2 – 8 W	150 W			55 W	
LED lamp > 8 W	180 W			70 W	
Fluorescent lamp load (electronic ballast)	1000 W			350 W	
Switching capacity	16 AX (at 230 V AC, cos φ = 0.3), 16 A (at 230 V AC, cos φ = 1)		10 AX (at 230 V AC, cos φ = 0.3), 16 A (at 230 V AC, cos φ = 1)		
Test approval					
Ambient temperature	–25 °C ... +50 °C				
Protection class	II				
Type of protection	IP 20				

### Accessories



**Wall mounting kit 17,5 mm**

↳ Art.No.: 9070065

Details page 334



**Front panel kit**

↳ Art.No.: 9070001

Details page 334

### Connection diagrams

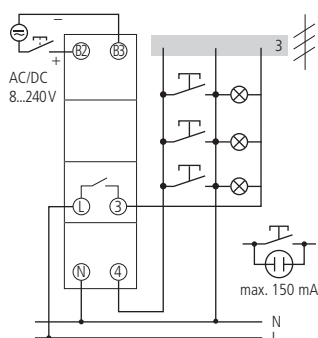

ELPA 1, ELPA 3

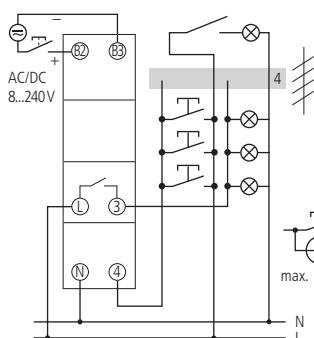

ELPA 1, ELPA 3

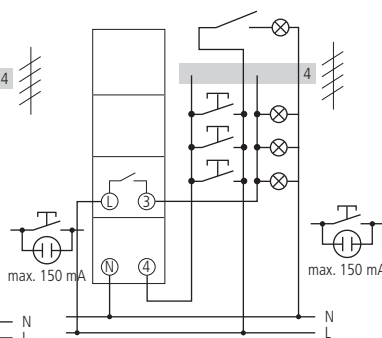

ELPA 6, ELPA 6 plus, ELPA 7

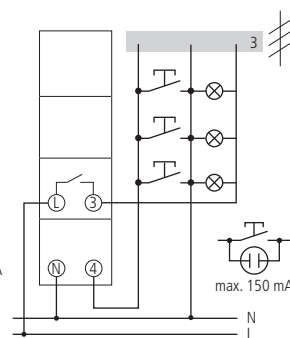

ELPA 6, ELPA 6 plus, ELPA 7

# Time and light control

## Staircase time switches, DIN rail, electro-mechanical

5



### Description

#### Common functions

- Staircase time switch, electro-mechanical
- No closed-circuit current consumption
- Toggle switch for permanent light ON
- Reliable due to synchronous motor drive
- Simplest possible time setting and direct delay time readout on absolute scale
- Precision mechanics and therefore exact switching period
- Very low sensitivity to interference

#### ELPA 8

- 4 conductor with floor lighting connection
- 3 conductor without floor lighting (no longer permitted for new systems)
- Retriggerable

#### ELPA 9

- 3 conductor connection and floor lighting, but without secondary switching (no longer permitted for new systems)
- Terminal layout same as ELPA 8

\* According to guarantee conditions, see [www.theben.de/en/guarantee](http://www.theben.de/en/guarantee)

### Product selection

Incandescent lamp load	Setting range time	Without stand-by consumption	Switch-off pre-warning	3/4-way conductors	Secondary switching	Type	Article number
2300 W	1-7 min	✓	-	Yes	After 30 s	ELPA 8	0080002
				Only 3-way conductor	No	ELPA 9	0090001

# Time and light control

## Staircase time switches, DIN rail, electro-mechanical

5

### Technical data

	ELPA 8	ELPA 9
Operating voltage	230 V AC	
Frequency	50 Hz	
Stand-by consumption	0 W	
Glow lamp load	50 mA	
Setting range time	1 – 7 min	
3/4-way conductors	Yes	Only 3-way conductor
Type of contact	NO contact	
Switching output	Not potential-free (230 V)	
Incandescent / halogen lamp load	2300 W	
Fluorescent lamp load (conventional) lead-lag circuit	2300 VA	
Fluorescent lamp load (conventional) parallel-corrected	1300 VA, 70 µF	
Energy saving lamps	150 W	
LED lamp < 2 W	30 W	
LED lamp 2-8 W	300 W	
LED lamp > 8 W	300 W	
Switching capacity	6 AX (at 230 V AC, cos φ = 0.3), 16 A (at 230 V AC, cos φ = 1)	
Test approval	VDE	-
Ambient temperature	-10 °C ... +50 °C	
Protection class	II	
Type of protection	IP 20	

### Accessories



Wall mounting kit 17,5 mm

↳ Art.No.: 9070065

Details page 334



Front panel kit

↳ Art.No.: 9070001

Details page 334

### Connection diagrams

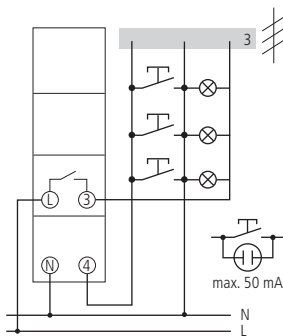

ELPA 8

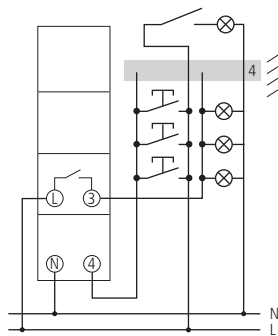

ELPA 8

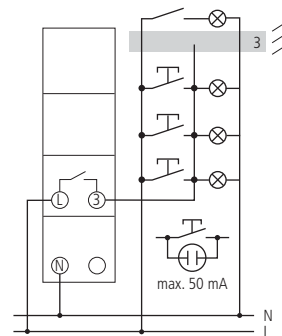

ELPA 9

# Time and light control

## Staircase time switches, Flush-mounted



5

### Description

#### Common functions

- Flush-mounted staircase time switch, electronic
- Suitable for upgrades and new installation
- Zero-cross switching for relay-saving switching and high lamp loads
- Push button input with electronic overload protection
- Automatic 3 or 4 conductor detection (4 conductor with connection for floor lighting, 3 conductor no longer permitted for new systems)
- Extremely accurate
- Immediate secondary switching

#### ELPA 041

- Multi-functional device with 12 available functions, set at the front of the device
- Switch or push button connectable, i.e. existing switches can be used (e.g. when updating)
- Additional multi-voltage input electrically isolated for AC/DC 8...240 V, e.g. für intercoms
- Switch-off pre-warning (two double flashes) in accordance with DIN 18015-2 to avoid sudden darkness
- 60 min. extended function activated via long button press

- Immediate secondary switching (stair light switch) or prematurely switched off (pulse switch with switch-off delay)

#### ELPA 047

- Push button connectable

### Product selection

Incandescent lamp load	Multi-function	Multi-voltage input	Switch-off pre-warning	Zero-cross switching	Type	Article number
1800 W	✓	✓	✓	✓	ELPA 041	0410002
	–	–	–	✓	ELPA 047	0470002

# Time and light control

## Staircase time switches, Flush-mounted

5

### Technical data

	ELPA 041	ELPA 047
Operating voltage	230 V AC	
Frequency	50 – 60 Hz	
Stand-by consumption	0,1 W	
Glow lamp load	30 mA	
Setting range time	0,5 – 20 min	
3/4-way conductors	Automatic	
Type of contact	NO contact	
Switching output	Not potential-free (230 V)	
Incandescent / halogen lamp load	1800 W	
Fluorescent lamp load (conventional) lead-lag circuit	1200 VA	
Fluorescent lamp load (conventional) parallel-corrected	580 VA, 54 µF	
Energy saving lamps	110 W	
LED lamp < 2 W	20 W	
LED lamp 2-8 W	250 W	
LED lamp > 8 W	250 W	
Switching capacity	6 AX (at 230 V AC, cos φ = 0.3), 10 A (at 230 V AC, cos φ = 1)	
Test approval	VDE	
Ambient temperature	-25 °C ... +45 °C	
Protection class	II	
Type of protection	IP 20	

### Scale drawings

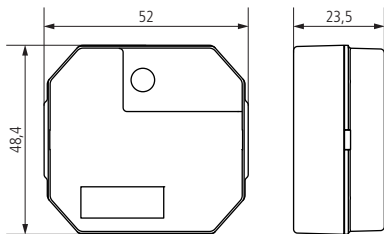

ELPA 041, ELPA 047

### Connection diagram

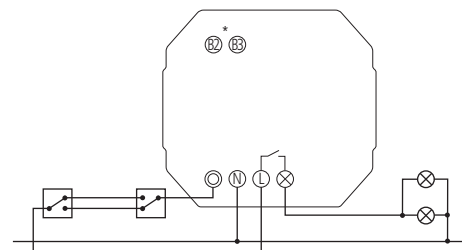

ELPA 041

\* with switch  
(with three-way switch the multi-voltage input is not usable)

### Connection diagrams

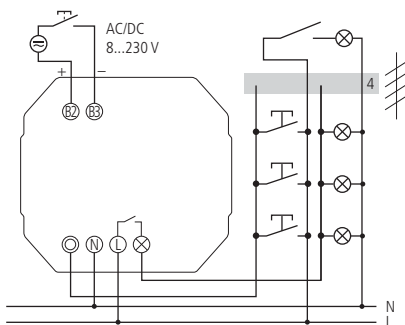

ELPA 041

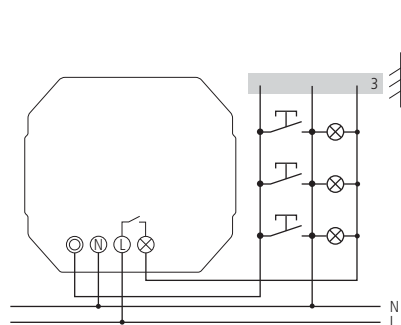

ELPA 047

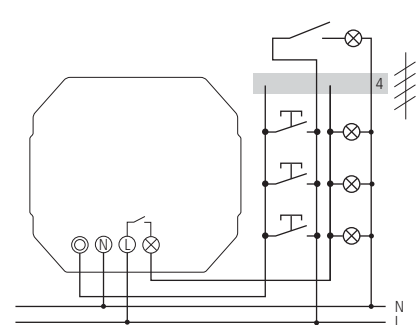

ELPA 047



DIMAX 532 plus

DIMAX 534 plus

### Description

#### Common functions

- Universal dimmer for R, L and C loads with automatic load detection
- Switch-on brightness can be saved individually
- Adjustable minimum brightness (required for ESL and LED)
- Multi-voltage input, e.g. for intercoms
- Low stand-by consumption
- Memory function in the event of power failure
- Automatic electronic overload and overheating switch-off
- Dimming switch-on function

- Permanent ON function (test function)
- No minimum load requirement
- Soft ON and Soft OFF protects the light
- The dimming output can be upgraded by using additional dimmboosters „DMB 1 T KNX“ - dimming output 300 W/VA for each dimmbooster

#### DIMAX 534 plus

- Comfort setting with wake-up and snooze function (can be deactivated), e.g. for children's bedrooms
- Adjustable dimming rate (with automatic functions)

- One and two button operation for ease of use
- Up to 3 light scenes can be called up via separate input (diode module required for more than one light scene)
- Central OFF/ON or light scene for up to 10 devices possible with one push button
- Staircase light function with dimming function in accordance with DIN 18015 - 2 (resettable, long-time function)
- Can be controlled by push buttons or switches e.g. for combination with presence detectors or time switch

### Product selection

Load detection	Optimized for energy-saving lamps	Light settings	Multi-function	Type	Article number
√	√	-	-	DIMAX 532 plus	5320001
		√	√	DIMAX 534 plus	5340001

### Technical data

	DIMAX 532 plus	DIMAX 534 plus
Operating voltage	230 V AC	
Frequency	50 Hz	
Stand-by consumption	0,2 W	
Incandescent / halogen lamp load	400 W	
Transformer electronic (C)	300 W	
Transformer inductive (L)	400 W	
Energy saving lamps	Trailing edge: 400 W	
LED lamp	Trailing edge: 400 W	
Ambient temperature	-30 °C ... +50 °C	
Protection class	II	
Type of protection	IP 20	

### Accessories



**Wall mounting kit 17,5 mm**  
↳ Art.No.: 9070065  
Details page 334



**Front panel kit**  
↳ Art.No.: 9070001  
Details page 334



**Diode module**  
for DIMAX 534 plus  
↳ Art.No.: 9070367  
Details page 342

### Connection diagrams

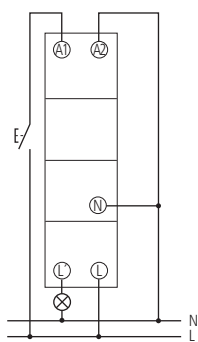

DIMAX 532 plus

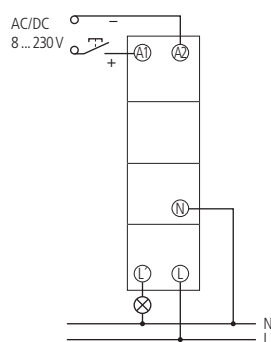

DIMAX 532 plus

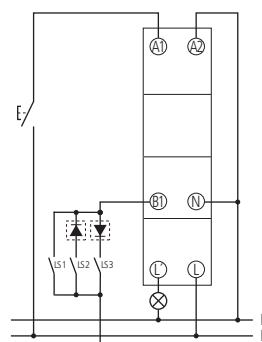

DIMAX 534 plus

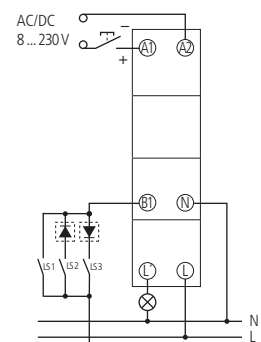

DIMAX 534 plus

# Time and light control

## Dimmer



5

### Description

#### Common functions

- Universal dimmer for R, L and C loads with automatic load detection
- Optimised settings for LEDs, incandescent lamps and energy-saving lamps
- Comfort setting with wake-up and snooze function (can be deactivated), e.g. for children's bedrooms
- Up to 2 light scenes

#### DIMAX 542 plus

- Settings through easily accessible potentiometer
- Switch-on brightness can be saved individually

#### DIMAX 544 plus

- Settings through easily accessible potentiometer or using a NFC capable smartphone (Near Field Communication)

- Programming is possible via an app, using the app there are advanced features configurable
- Adjustable dimming rate (with automatic functions)
- Special settings can only be set using the app, for double or rocker switch or staircase time switch and alternative dimming curves

### Product selection

Load detection	Optimized for energy-saving lamps/LED	Light settings	Operation via App possible	Type	Article number
✓	✓	–	–	DIMAX 542 plus	5420001
		✓	✓	DIMAX 544 plus	5440001

### Technical data

	DIMAX 542 plus	DIMAX 544 plus
Operating voltage	230 V AC	
Frequency	50 Hz	
Stand-by consumption	0,25 W	
Incandescent / halogen lamp load	250 W	
Transformer electronic (C)	250 W	
Energy saving lamps	Trailing edge: 200 W	
LED lamp	Trailing edge: 250 W	
Ambient temperature	-25 °C ... +45 °C	
Protection class	II	
Type of protection	IP 20	

### Scale drawings

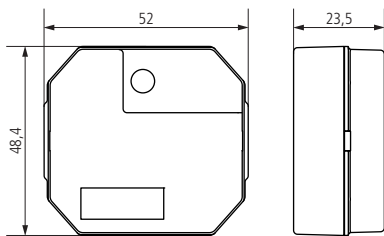

DIMAX plus

### Accessories



Diode module

↳ Art.No.: 9070367

Details page 342



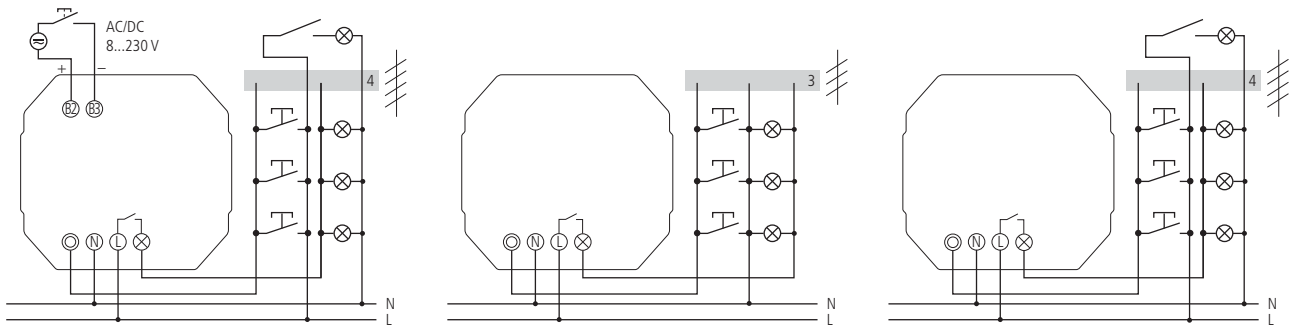







### Connection diagrams





## The right moment

What we don't consume today is still available to us tomorrow and for our children's generation. Often that doesn't mean having to do without anything. It means only using our resources when we actually need them. Theben contributes to this with a multitude of clever innovations such as twilight switches are one of these. That's what we mean by sustainability.

	Number of channels	Setting range brightness	Switch-on delay	Separate on/off switching delay	External inputs	PC interface	Program	Type of connection	Type	Page
<b>Analogue, DIN rail</b>										
	1	2–100 lx	20 s	–	–	–	–	Screw terminals	LUNA 108	86
		2–2000 lx	60 s	–	–	–	–	DuoFix spring terminals	LUNA 109	86
		2–50000 lx	0–20 min	–	–	–	–	DuoFix spring terminals	LUNA 110	86
		2–2000 lx	0–59 min	✓	–	✓	Weekly program	DuoFix spring terminals	LUNA 120 top2	90
<b>Digital without clock, DIN rail</b>										
	1	1–99000 lx	0–59 min	✓	1	✓	–	DuoFix spring terminals	LUNA 111 top2	88
	2	1–99000 lx	0–59 min	✓	2	✓	–	DuoFix spring terminals	LUNA 112 top2	88
<b>Digital, DIN rail</b>										
	1	1–99000 lx	0–59 min	✓	1	✓	Weekly program	DuoFix spring terminals	LUNA 121 top2 RC	90
	2	1–99000 lx	0–59 min	✓	2	✓	Weekly program	DuoFix spring terminals	LUNA 122 top2 RC	90
<b>Analogue, Wall installation or mast bracket</b>										
	1	5–200 lx	40 s	–	–	–	–	Screw terminals	LUNA 126 star	92
		2–200 lx	2–100 s	–	–	–	–	Screw terminals	LUNA 127 star	92
		2–2000 lx	2–100 s	–	–	–	–	Screw terminals	LUNA 128 star	92
<b>Digital, Wall installation or mast bracket</b>										
	1	2–200 lx	0–10 min	✓	–	–	Daily program	Screw terminals	LUNA 129 star-time	92

# Time and light control

## Twilight switches, Analogue, DIN rail



LUNA 108

LUNA 109

LUNA 110

6

### Description

#### Common functions

- Analogue twilight switch
- External light sensor included in delivery
- Display of channel and switching status
- Infinitely adjustable switching brightness

#### LUNA 108

- Fixed On and Off switching delay

#### LUNA 109

- DuoFix spring terminals
- Fixed On and Off switching delay
- Test function

#### LUNA 110

- Adjustable On and Off switching delay
- DuoFix spring terminals
- Extended brightness levels and adjustable delay

- Five adjustable brightness levels for simple setting of lux value
- Zero-cross switching for relay-saving switching and high lamp loads (not with 24 V devices)
- Permanent OFF and permanent ON function can be set on the potentiometer
- Test function

### Product selection

Setting range brightness	Switch-on delay	Type of connection	Operating voltage	Sensor (included)	Type of protection	Type	Article number
2–100 lx	20 s	Screw terminals	220–240 V AC	Surface-mounted light sensor	IP 20, sensor IP 54	LUNA 108 AL	1080710
				Flush-mounted light sensor	IP 20, sensor IP 65	LUNA 108 EL	1080700
2–2000 lx	60 s	DuoFix spring terminals	220–240 V AC	Surface-mounted light sensor	IP 20, sensor IP 55	LUNA 109 AL	1090100
				Flush-mounted light sensor	IP 20, sensor IP 65	LUNA 109 EL	1090200
2–50000 lx	0–20 min	DuoFix spring terminals	220–240 V AC	Surface-mounted light sensor	IP 20, sensor IP 55	LUNA 110 AL	1100100
				Flush-mounted light sensor	IP 20, sensor IP 65	LUNA 110 EL	1100200
			12–24 V UC	Surface-mounted light sensor	IP 20, sensor IP 55	LUNA 110 AL 24V	1104100
				Flush-mounted light sensor	IP 20, sensor IP 65	LUNA 110 EL 24V	1104200

### Technical data

	LUNA 108	LUNA 109	LUNA 110	LUNA 110 24V
Operating voltage	220–240 V AC			12–24 V UC
Frequency	50–60 Hz			
Stand-by consumption	0,8 W	1,1 W	1,3 W	0,2 W
Setting range brightness	2–100 lx	2–2000 lx	2–50000 lx	
Switch-on delay	20 s	60 s	0–20 min	
Type of contact	NO contact	Changeover contact		
Switching output	Potential-free		Potential-free, not for SELV	Potential-free
Width	1 module	2 modules		
Switching capacity	16 A (at 250 V AC, cos φ = 1), 10 AX (Fluorescent lamp load)		16 A (at 250 V AC, cos φ = 1), 16 AX (Fluorescent lamp load)	16 A (at 250 V AC, cos φ = 1), 2 AX (Fluorescent lamp load)
Switching capacity min.	–	<10 mA		
Incandescent lamp load	2300 W		3600 W	1400 W
Fluorescent lamp load (conventional) not corrected, series-corrected, lead-lag circuit	2300 VA		3600 VA	1400 VA
Fluorescent lamp load (conventional) parallel-corrected	400 VA, 42 μF		1200 VA, 130 μF	58 W, 7 μF
LED lamp < 2 W	20 W		50 W	6 W
LED lamp 2–8 W	55 W		160 W	20 W
LED lamp > 8 W	70 W		200 W	24 W
Energy saving lamps	90 W		270 W	45 W
Fluorescent lamp load (electronic ballast)	300 W		1000 W	120 W
Test approval	VDE			–
Ambient temperature	–25 °C ... +50 °C		–30 °C ... +55 °C	
Protection class	II		II, Sensor III	
Max. cable length to sensor	25 m		100 m	

### Accessories



**Wall mounting kit 17,5 mm**  
for LUNA 108  
↳ Art.No.: 9070065  
Details page 334



**Wall mounting kit 35 mm**  
for LUNA 109, LUNA 110  
↳ Art.No.: 9070064  
Details page 334



**Front panel kit**  
↳ Art.No.: 9070001  
Details page 334

**Surface-mounted light sensor**  
Details page 342

**Analogue surface-mounted light sensor**  
Details page 342

**Analogue flush-mounted light sensor**  
Details page 341

### Connection diagrams

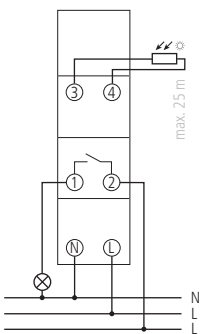

LUNA 108

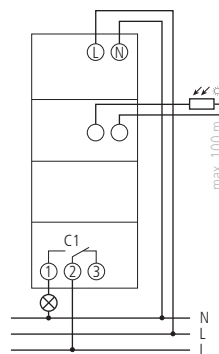

LUNA 109, LUNA 110

## Time and light control

### Twilight switches, Digital without clock, DIN rail



LUNA 111 top2

LUNA 112 top2

6

#### Description

##### Common functions

- Light level controller
- External light sensor included in delivery
- Switching brightness digitally adjustable
- Adjustable On and Off switching delay
- Switching brightness and switching delay can be set separately for switching On and Off
- Onscreen display of channel and switching status as well as current lux value
- DuoFix spring terminals
- Zero-cross switching for relay-saving switching and high lamp loads (not with 24 V devices)
- Up to 4 sensors can be attached
- Up to 10 devices can be connected to a digital sensor
- Interface for OBELISK top2 memory card (PC programming)
- External light sensor included in delivery
- Extended brightness range
- Permanent switching ON/OFF
- Test function
- Switching preselection
- Display back light (can be turned off)
- External input
- Operating hour counter

##### LUNA 111 top2

- 1 channel
- External control input

##### LUNA 112 top2

- 2 channels
- 2 external control inputs
- Channel-independent operating hour counter

#### Product selection

Number of channels	External inputs	Switch-on delay	Sensor (included)	Type of protection	Type	Article number
1	1	0–59 min	Surface-mounted light sensor	IP 20, sensor IP 55	LUNA 111 top2 AL	1110100
			Flush-mounted light sensor	IP 20, sensor IP 66 (Front)   IP 40 (Back)	LUNA 111 top2 EL	1110200
2	2	0–59 min	Surface-mounted light sensor	IP 20, sensor IP 55	LUNA 112 top2 AL	1120100
			Flush-mounted light sensor	IP 20, sensor IP 66 (Front)   IP 40 (Back)	LUNA 112 top2 EL	1120200

# Time and light control

## Twilight switches, Digital without clock, DIN rail

### Technical data

	LUNA 111 top2	LUNA 112 top2
Operating voltage	230–240 V AC	100–240 V AC
Frequency	50–60 Hz	
Stand-by consumption	1,7 W	1,3 W
Setting range brightness	1–99000 lx	
Switch-on delay	0–59 min	
Type of contact	Changeover contact	2 changeover contacts
Switching output	Potential-free, not for SELV	
Width	2 modules	3 modules
Switching capacity	16 A (at 250 V AC, $\cos \varphi = 1$ ), 10 A (at 250 V AC, $\cos \varphi = 0.6$ ), 10 AX (Fluorescent lamp load)	
Switching capacity min.	Approx. 10 mA	
Incandescent lamp load	2600 W	
Fluorescent lamp load (conventional) not corrected, series-corrected, lead-lag circuit	2300 VA	
Fluorescent lamp load (conventional) parallel-corrected	800 VA, 80 $\mu$ F	
LED lamp < 2 W	30 W	
LED lamp 2–8 W	100 W	
LED lamp > 8 W	120 W	
Energy saving lamps	170 W	
Fluorescent lamp load (electronic ballast)	650 W	
Test approval	VDE	
Ambient temperature	–30 °C ... +55 °C	
Protection class	II, Sensor III	
Max. cable length to sensor	100 m	

### Accessories



PC set OBELISK top2/3  
↳ Art.No.: 9070409  
Details page 335



Memory card OBELISK top2  
↳ Art.No.: 9070404  
Details page 335



Front panel kit  
↳ Art.No.: 9070001  
Details page 334

Digital surface-mounted light sensor  
Details page 342

Digital flush-mounted light sensor  
Details page 342

Wall mounting kit 35 mm  
Details page 334

Wall mounting kit 52,5 mm  
Details page 334

### Connection diagrams

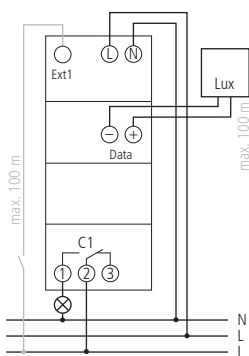

LUNA 111 top2

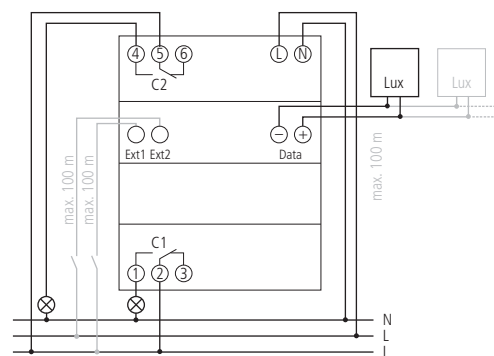

LUNA 112 top2

# Time and light control

## Twilight switches, Digital, DIN rail, Analogue



6

### Description

#### Common functions

- Twilight switch with integrated weekly timer
- External light sensor included in delivery
- Fixed ON and OFF times (e.g. nighttime interruption)
- Different summer/winter time rules can be selected or freely defined
- Adjustable On and Off switching delay
- Switching brightness and switching delay can be set separately for switching On and Off
- DuoFix spring terminals
- Zero-cross switching for relay-saving switching and high lamp loads (not with 24 V devices)
- Interface for OBELISK top2 memory card (PC programming)
- Permanent switching ON/OFF
- Test function

- Switching preselection
- Display back light (can be turned off)
- Variable lux values can be set for each day
- Holiday and public holiday program with yearly function for fixed and public holidays dependent on Easter
- Operating hour counter

#### LUNA 121 top2 RC

- 1 channel
- 1 special program with yearly function
- DCF77 or GPS radio controlled time via external antenna
- Switching brightness digitally adjustable
- Onscreen display of channel and switching status as well as current lux value
- Up to 4 sensors can be attached
- Up to 10 devices can be connected to a digital sensor
- Extended brightness range
- External input

#### LUNA 122 top2 RC

- 2 channels
- 2 special programmes with yearly function
- DCF77 radio controlled via external antenna
- 2 external inputs
- Switching brightness digitally adjustable
- Onscreen display of channel and switching status as well as current lux value
- Up to 4 sensors can be attached
- Up to 10 devices can be connected to a digital sensor
- Extended brightness range
- External input

#### LUNA 120 top2

- Analogue adjustable switching brightness
- Onscreen display of channel and switching status
- 1 channel

### Product selection

Number of channels	External inputs	Additional program	Operating voltage	Sensor (included)	Type of protection	Type	Article number
1	1	Extra/Holiday program	230–240 V AC	Surface-mounted light sensor	IP 20, sensor IP 55	LUNA 121 top2 RC AL	1210100
				Flush-mounted light sensor	IP 20, sensor IP 66 (Front)   IP 40 (Back)	LUNA 121 top2 RC EL	1210200
			12–24 V UC	Surface-mounted light sensor	IP 20, sensor IP 55	LUNA 121 top2 RC AL 24V	1214100
2	2	Extra/Holiday program	100–240 V AC	Surface-mounted light sensor	IP 20, sensor IP 55	LUNA 122 top2 RC AL	1220100
				Flush-mounted light sensor	IP 20, sensor IP 66 (Front)   IP 40 (Back)	LUNA 122 top2 RC EL	1220200
1	–	Holiday program	220–240 V AC	Surface-mounted light sensor	IP 20, sensor IP 55	LUNA 120 top2 AL	1200100
				Flush-mounted light sensor	IP 20, sensor IP 65	LUNA 120 top2 EL	1200200

### Technical data

	LUNA 121 top2 RC	LUNA 121 top2 RC 24V	LUNA 122 top2 RC	LUNA 120 top2
Operating voltage	230–240 V AC	12–24 V UC	100–240 V AC	220–240 V AC
Frequency	50–60 Hz			
Stand-by consumption	1,3 W	0,8 W	1,3 W	
Setting range brightness	1–99000 lx			2–2000 lx
Switch-on delay	0–59 min			
Type of contact	Changeover contact		2 changeover contacts	Changeover contact
Switching output	Potential-free, not for SELV	Potential-free	Potential-free, not for SELV	
Width	2 modules		3 modules	
Switching capacity	16 A (at 250 V AC, cos φ = 1), 10 A (at 250 V AC, cos φ = 0.6), 10 AX (Fluorescent lamp load)	16 A (at 250 V AC, cos φ = 1), 2 AX (Fluorescent lamp load)	16 A (at 250 V AC, cos φ = 1), 10 A (at 250 V AC, cos φ = 0.6), 10 AX (Fluorescent lamp load)	
Switching capacity min.	Approx. 10 mA			
Incandescent lamp load	2600 W	1400 W	2600 W	
Fluorescent lamp load (conventional) not corrected, series-corrected, lead-lag circuit	2300 VA	1400 VA	2300 VA	
Fluorescent lamp load (conventional) parallel-corrected	800 VA, 80 μF	58 W, 7 μF	800 VA, 80 μF	
LED lamp < 2 W	30 W	6 W	30 W	
LED lamp 2–8 W	100 W	20 W	100 W	
LED lamp > 8 W	120 W	24 W	120 W	
Energy saving lamps	170 W	45 W	170 W	
Fluorescent lamp load (electronic ballast)	650 W	180 W	650 W	
Test approval		–		
Ambient temperature	–30 °C ... +55 °C			
Protection class	II, Sensor III			
Max. cable length to sensor	100 m			

### Accessories



**PC set OBELISK top2/3**  
↳ Art.No.: 9070409  
Details page 335



**Memory card OBELISK top2**  
↳ Art.No.: 9070404  
Details page 335



**Antenna top2 RC-DCF**  
for LUNA 121 top2 RC,  
LUNA 122 top2 RC  
↳ Art.No.: 9070410  
Details page 335

**Light sensors**  
Details page 341

**Wall mounting kits**  
Details page 334

**Front panel kit**  
Details page 334

**Antenna top2 RC-GPS**  
Details page 335

**Power unit top2 GPS**  
Details page 336

### Connection diagrams

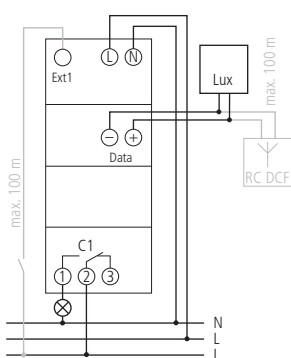

LUNA 121 top2 RC

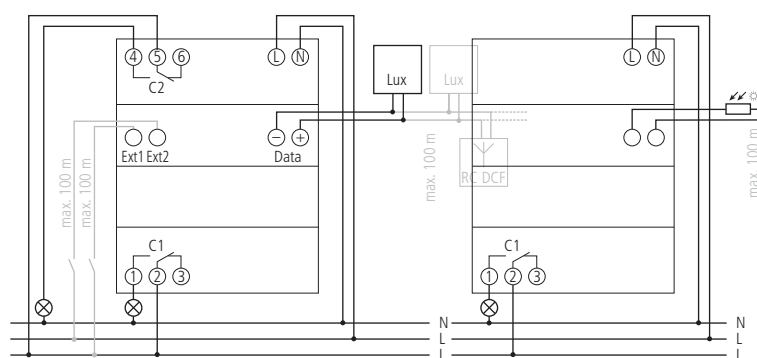

LUNA 122 top2 RC

LUNA 120 top2

## Time and light control

### Twilight switches, Wall installation or mast bracket



6

LUNA 126 star

LUNA 129 star-time

#### Description

##### Common functions

- Twilight switch with integrated light sensor
- Cable feed from the back and from below
- Captive screws
- Large terminal area
- Brightness value can be set without opening the device
- Large light exposure angle (approx. 180 degrees)

##### LUNA 126 star

- Fixed On and Off switching delay
- Infinitely adjustable switching brightness

##### LUNA 127 star

- Adjustable On and Off switching delay
- Test button
- Infinitely adjustable switching brightness

##### LUNA 128 star

As LUNA 127 star, but:

- Expanded brightness range
- for monitoring installation independent of set brightness value. The button can be accessed without opening the device

##### LUNA 129 star-time

- Time function for freely-programmable night switch-off (daily program)

- Adjustable On and Off switching delay
- Easy programming philosophy
- Preset night switch-off (23.00 OFF/5.00 ON), lux values and switch delay
- Automatic summer/winter time correction
- Integrated replaceable lithium battery enables programming before installation
- Switching brightness and switching delay can be set digitally for switching On and Off separately
- Test button
- Time function can be deactivated

#### Product selection

Setting range brightness	Switch-on delay	Switching capacity at 230 V AC	Time program	Type	Article number
5–200 lx	40 s	16 (10) A AX	–	LUNA 126 star	1260700
2–200 lx	2–100 s	16 (10) A AX	–	LUNA 127 star	1270700
2–2000 lx	2–100 s	16 (10) A AX	–	LUNA 128 star	1280700
2–200 lx	0–10 min	16 (10) A AX	Daily program	LUNA 129 star-time	1290700

# Time and light control

## Twilight switches, Wall installation or mast bracket

### Technical data

	LUNA 126 star	LUNA 126 star	LUNA 127 star	LUNA 128 star	LUNA 129 star-time
Operating voltage	220–230 V AC				
Frequency	50–60 Hz				
Stand-by consumption	0,6 W				
Setting range brightness	5–200 lx		2–200 lx	2–2000 lx	2–200 lx
Switch-on delay	40 s		2–100 s		0–10 min
Type of contact	NO contact				
Switching output	Not potential-free (230 V)				
Switching capacity	16 A (at 230 V AC, $\cos \varphi = 1$ ), 10 AX (at 230 V AC, $\cos \varphi = 0.3$ )				
Incandescent lamp load	2300 W				
Fluorescent lamp load (conventional) not corrected	2300 VA				
Fluorescent lamp load (conventional) series-corrected	2300 VA				
Fluorescent lamp load (conventional) lead-lag circuit	2300 VA				
Energy saving lamps	90 W				
LED lamp < 2 W	20 W				
LED lamp 2–8 W	55 W				
LED lamp > 8 W	70 W				
Test approval	VDE				
Ambient temperature	-35 °C ... +55 °C				
Type of protection	IP 55				
Protection class	II				

6

### Accessories



#### Adapter plate LUNA star

↳ Art.No.: 9070486

Details page 341

### Scale drawings

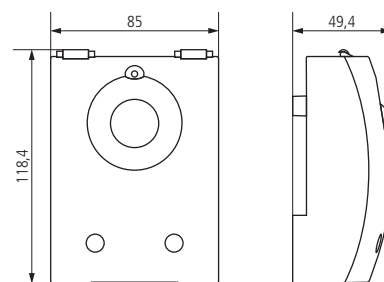

LUNA 126 star, LUNA 127 star, LUNA 128 star, LUNA 129 star-time

### Connection diagrams

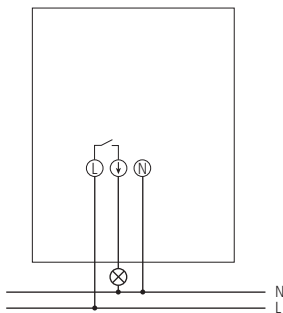

LUNA 126 star, LUNA 127 star, LUNA 128 star

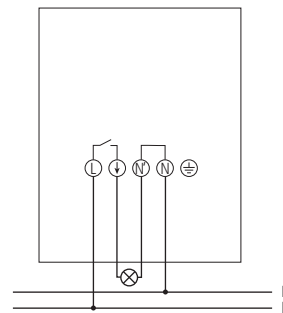

LUNA 129 star-time

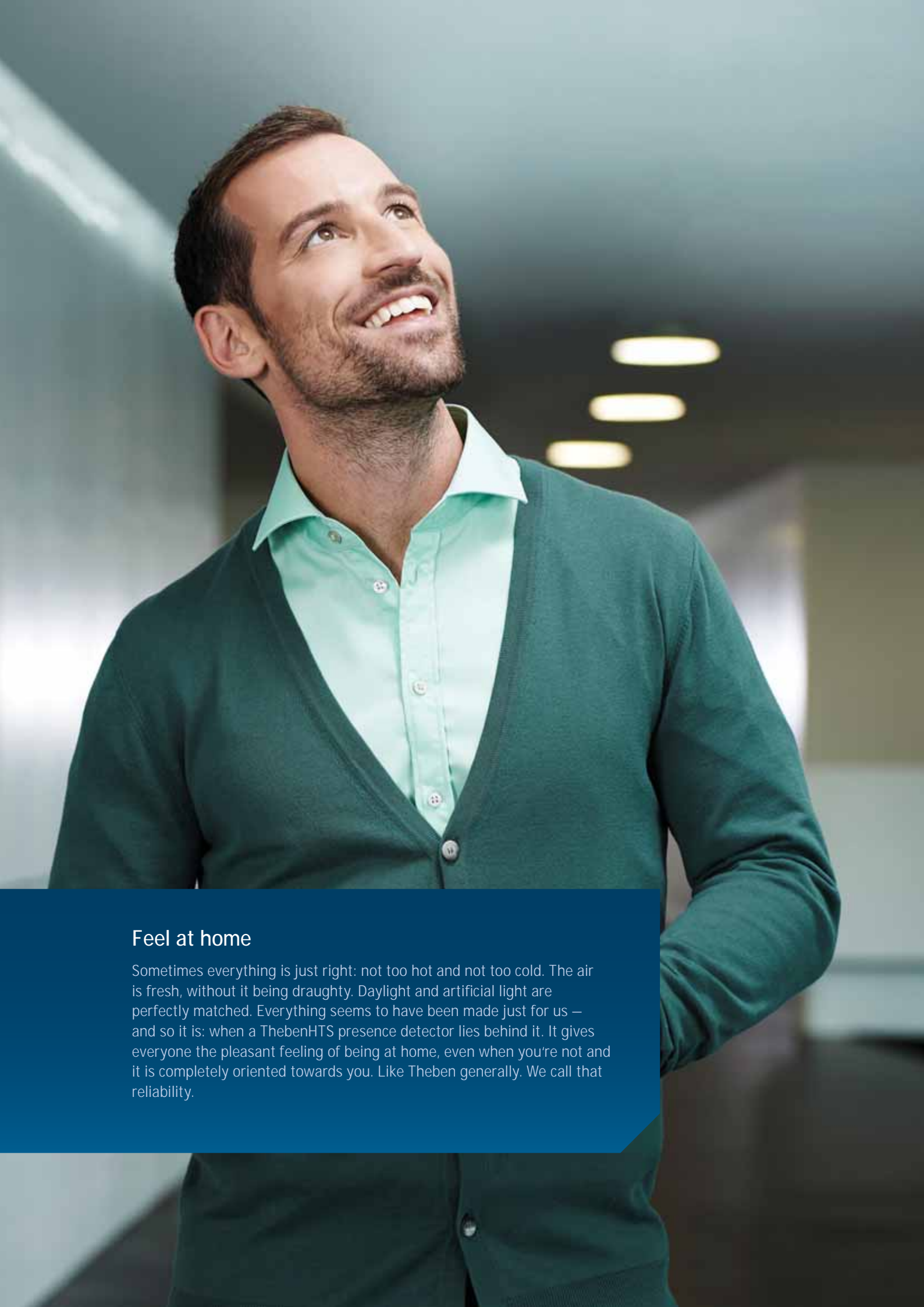

## Feel at home

Sometimes everything is just right: not too hot and not too cold. The air is fresh, without it being draughty. Daylight and artificial light are perfectly matched. Everything seems to have been made just for us – and so it is: when a ThebenHTS presence detector lies behind it. It gives everyone the pleasant feeling of being at home, even when you're not and it is completely oriented towards you. Like Theben generally. We call that reliability.

# Presence and motion detectors

## Presence detectors

	Installation type	Detection range - Sitting   3,0 m -	Detection range - Walking   3,0 m -	Channel	Function	Type of protection	Type	Page
<b>230 V AC</b>								
	Ceiling	20 m² (4,5 x 4,5 m)	49 m² (7,0 x 7,0 m)	Light	Switching	IP 54	PresenceLight 360	96
		3 m² (ø 2,0 m   360°)	50 m² (ø 8 m   360°)	Light	Switching	IP 20	thePiccola P360-100 DE	98
		20 m² (ø 5,0 m   360°)	133 m² (ø 13 m   360°)	Light	Switching	IP 41	SPHINX 104-360	100
							SPHINX 104-360 AP	100
				Light   Presence	Switching	IP 41	SPHINX 104-360/2	100
							SPHINX 104-360/2 AP	100
		28 m² (ø 6,0 m   360°)	452 m² (ø 24 m   360°)	Light   Presence	Switching	IP 40	SPHINX 104-360/2 DIMplus	102
		3 m² (ø 4,0 m   360°)	50 m² (ø 8 m   360°)	Light	Switching	IP 54	theRonda S360-100 DE	104
				Light   Presence	Switching	IP 54	theRonda S360-101 DE	104
				Light	Switching	IP 54	theRonda S360-100 AP	106
				Light   Presence	Switching	IP 54	theRonda S360-101 AP	106
				Light	Switching	IP 54	theRonda S360-100 GST/WINSTA	108
		50 m² (ø 8,0 m   360°)	452 m² (ø 24 m   360°)	Light	Switching	IP 54	theRonda P360-100 M	110
				Light   Presence	Switching	IP 54	theRonda P360-101 M	110
				Light	Switching	IP 54	theRonda P360-100 GST/WINSTA	112
		20 m² (4,5 x 4,5 m)	49 m² (7,0 x 7,0 m)	Light   1-10 V	Dimming	IP 40	compact office DIM	114
		90 m² (20 x 4,5 m)	135 m² (30,0 x 4,5 m)	Light   Presence	Switching	IP 40	compact passage	116
							compact passage GST/WINSTA	118
		45 m² (10 x 4,5 m)	68 m² (15,0 x 4,5 m)	Light   Presence	Switching	IP 40	compact passimo	120
		25 m² (5,0 x 5,0 m)	49 m² (7,0 x 7,0 m)	Light	Switching	IP 40	thePrema S360-100 E	122
				Light   Presence	Switching	IP 40	thePrema S360-101 E	122
		49 m² (7,0 x 7,0 m)	81 m² (9,0 x 9,0 m)	Light   Presence	Switching	IP 40	thePrema P360-101 E	124
				2 x Light	Switching	IP 40	ECO-IR DUAL-C NT	126
		49 m² (7,0 x 7,0 m)	81 m² (9,0 x 9,0 m)	Light   Presence	Switching	IP 40	PlanoCentro 101-EWH/UWH	128
				3 x Light	Switching	IP 40	PlanoCentro 300-EWH/UWH	130
				2 x Light   1 x Presence	Switching	IP 40	PlanoCentro 201-EWH/UWH	130
	Wall	28 m² (ø 7,0 m   180°)	100 m² (ø 16 m   180°)	Light	Switching	IP 54	PresenceLight 180	134
<b>24 V AC/DC</b>								
	Ceiling	20 m² (4,5 x 4,5 m)	49 m² (7,0 x 7,0 m)	Light   Presence	Switching 24 V	IP 40	compact office 24V	136
							compact office 24V Lux	138
		90 m² (20 x 4,5 m)	135 m² (30,0 x 4,5 m)	Light   Presence	Switching 24 V	IP 40	compact passage 24V	140
<b>DALI</b>								
	Ceiling	25 m² (5,0 x 5,0 m)	49 m² (7,0 x 7,0 m)	1 channel Broadcast	Dimming	IP 40	thePrema S360 DALI	142
		50 m² (ø 8,0 m   360°)	452 m² (ø 24 m   360°)	3 channels addressable	Dimming	IP 54	theRonda P360-330 DALI	144
				1 channel Broadcast	Dimming	IP 54	theRonda P360-110 DALI	144
		13 m² (ø 4 m   360°)	50 m² (ø 8 m   360°)	1 channel Broadcast	Dimming	IP 54	theRonda S360-110 DALI	144
		20 m² (4,5 x 4,5 m)	49 m² (7,0 x 7,0 m)	-	-	IP 20	PlanoSpot 360 DALI	146
<b>LON</b>								
	Ceiling	20 m² (4,5 x 4,5 m)	49 m² (7,0 x 7,0 m)	2 x Light   3 x Occupancy	LON	IP 40	PresenceLight 360 PLLON	148
		49 m² (7,0 x 7,0 m)	81 m² (9,0 x 9,0 m)	3 x Light   3 x Occupancy	LON	IP 40	PlanoCentro E PCLON	150
							PlanoCentro U PCLON	150
		20 m² (4,5 x 4,5 m)	49 m² (7,0 x 7,0 m)	3 x Light   3 x Occupancy	LON	IP 20	PlanoSpot 360 PSLON	152
	Wall	28 m² (ø 7,0 m   180°)	100 m² (ø 16 m   180°)	2 x Light   3 x Occupancy	LON	IP 40	PresenceLight 180 PLLON	154

# Presence and motion detectors

## Presence detectors, 230 V AC



### Description

- Presence detector (PIR)
- Automatic control of lighting depending on presence and brightness
- Square detection area allows accurate and simple planning
- Cover frame in white included in delivery, cover frames in black or silver available as optional accessories
- IP 54 for versatile use
- Light switch output (relay, 230 V)
- Mixed light measurement, suitable for fluorescent lamps (FL/PL/ESL), halogen/incandescent lamps and LEDs
- Brightness threshold and self-learning switch-off delay adjustable
- Pulse function for staircase time switch
- Parameters can be set using the potentiometers or via the optional service remote controls
- Optional user remote control
- Ready for use by ex-factory set items
- Test operation to check detection area and installation
- Ceiling mounting in flush-mounted box
- Possibility of surface mounting by using a surface frame

### Product selection

Installation type	Channel	Operating voltage	Colour	Type	Article number
Ceiling installation	Light	230 V AC	Pure white (similar to RAL 9010)	PresenceLight 360	2000000

7

### Technical data

	PresenceLight 360
Operating voltage	230 V AC
Frequency	50 Hz
Installation height	2 – 3,5 m
Power consumption	0,7 W
Setting range brightness	Approx. 10 – 1500 lx/on
Light switch-off delay	Pulse (0,5 s), 10 s – 20 min
Type of contact light	Relay 230 V
Resistive load	1400 W
Incandescent/halogen lamp load	1200 W
Compact and fluorescent lamps	960 VA (cos φ = 0,8), 580 VA (cos φ = 0,5)
Compact and fluorescent lamps (max. number of electronic ballasts)	10 x (1 x 54/58 W), 5 x (2 x 54/58 W), 16 x (1 x 35/36 W), 8 x (2 x 35/36 W), 16 x (smaller than 35/36 W)
LED lamp < 2 W	25 W
LED lamp 2 – 8 W	70 W
LED lamp > 8 W	80 W
Size of concealed housing	Ø 55 mm (NIS, PMI)
Ambient temperature	–20 °C ... +50 °C
Type of protection	IP 54

Detection range (Square)

Mounting height (A)	Walking (T)	Sitting (S)
2 m	20 m <sup>2</sup>   4,5 m x 4,5 m ± 0,5 m	9 m <sup>2</sup>   3 m x 3 m
2,5 m	36 m <sup>2</sup>   6 m x 6 m ± 0,5 m	16 m <sup>2</sup>   4 m x 4 m
3 m	49 m <sup>2</sup>   7 m x 7 m ± 1 m	20 m <sup>2</sup>   4,5 m x 4,5 m
3,5 m	64 m <sup>2</sup>   8 m x 8 m ± 1 m	-

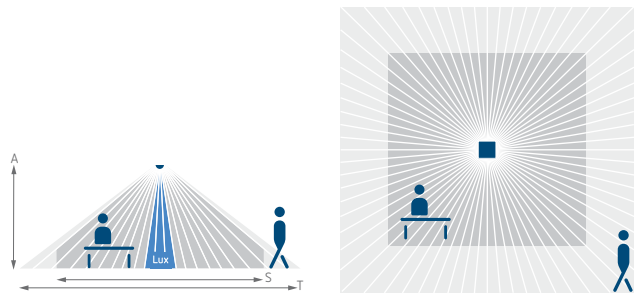

Accessories



Surface frame PresenceLight  
↳ Art.No.: 9070513  
Details page 336



SendoPro 868-A  
↳ Art.No.: 9070675  
Details page 339

QuickSafe

Details page 338

Cover frame PresenceLight  
360 SR

Details page 336

Cover frame PresenceLight  
360 BK

Details page 336

Surface frame PresenceLight BK  
Details page 336

Surface frame PresenceLight SR  
Details page 336

Ceiling installation box 73A  
Details page 337

Scale drawings

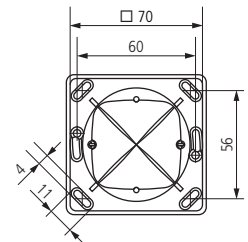
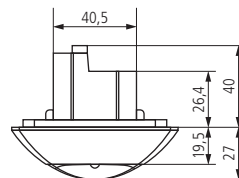
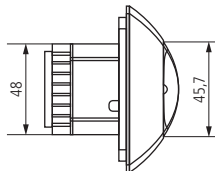
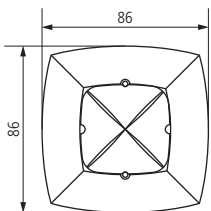

Connection diagrams

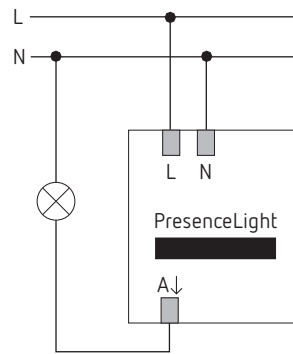
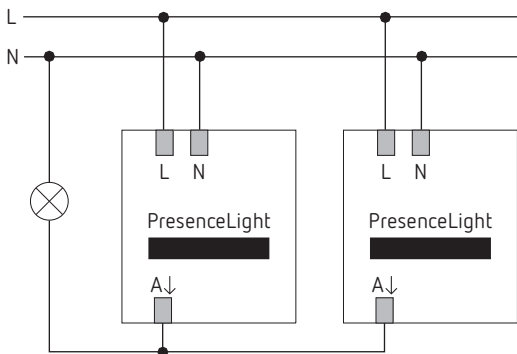

# Presence and motion detectors

## Presence detectors, 230 V AC



### Description

- Passive infra-red presence detector for ceiling installation
- Circular detection area 360°, up to Ø 8 m (50 m<sup>2</sup>)
- Automatic presence- and brightness-dependent control for lighting
- Mixed light measurement suitable for fluorescent lamps (FL/PL/ESL), halogen/ incandescent lamps and LEDs
- Channel A light: relay, 230 V
- Choice of fully or semi-automatic operation
- Brightness switching value configurable, teach-in function
- Pulse function for staircase light time switch
- Time delay configurable
- Test mode for checking function and detection area
- Connection option for sensor for manual switching
- Extension of detection area via Master/ Slave switching
- Ready for immediate use due to factory presetting
- Diameter of ceiling cutout 34–36 mm
- Remote controllable with optionally remote controls SendoPro, theSenda P and theSenda S

7

### Product selection

Installation type	Channel	Operating voltage	Colour	Type	Article number
Ceiling installation	Light	110–240 V AC	White	thePiccola P360-100 DE WH	2090200

### Technical data

thePiccola P360-100 DE WH			
Operating voltage	110–240 V AC	Fluorescent lamp load (conventional) parallel-corrected	1300 VA, 140 µF
Frequency	50–60 Hz	Fluorescent lamp load (conventional) series-corrected	2000 VA
Installation height	2–4 m	Fluorescent lamp load (electronic ballast)	1200 W
Power consumption	0,4 W	LED lamp < 2 W	55 W
Setting range brightness	5–1000 lx	LED lamp 2–8 W	180 W
Light switch-off delay	30 s–30 min	LED lamp > 8 W	200 W
Incandescent/halogen lamp load	2000 W	Ambient temperature	–20 °C ... +50 °C
Fluorescent lamp load (conventional) not corrected	2000 VA	Type of protection	IP 21 (Sensor), IP 20 (power module)

### Detection range (Round)

Mounting height (A)	Sitting (S)	Head on to (r)	Diagonally (T)
2,5 m	3 m <sup>2</sup>   2 m	3 m <sup>2</sup>   2 m	50 m <sup>2</sup>   8 m

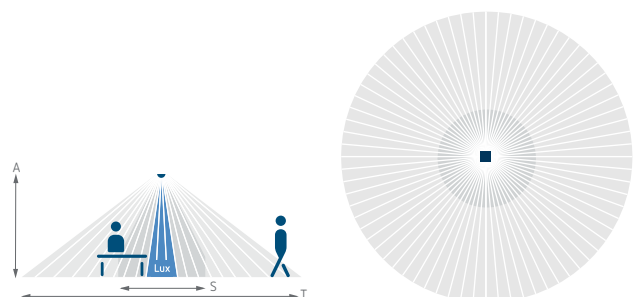

Accessories



SendoPro 868-A  
↳ Art.No.: 9070675  
Details page 339



theSenda P  
↳ Art.No.: 9070910  
Details page 341



theSenda S  
↳ Art.No.: 9070911  
Details page 341

Scale drawings

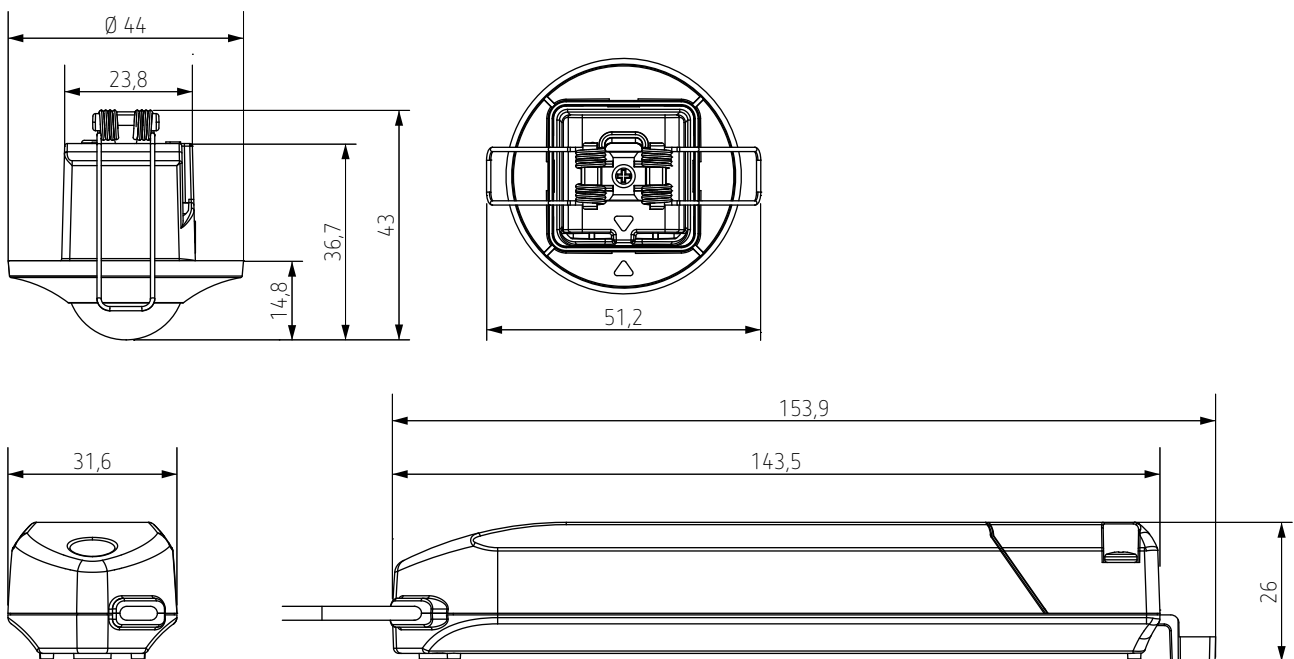

7

Connection diagrams

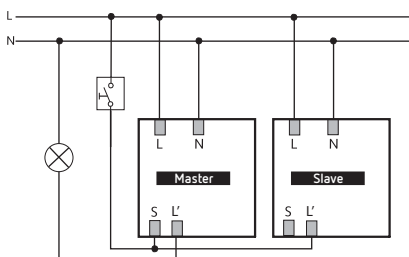

thePiccola P360-100 DE WH

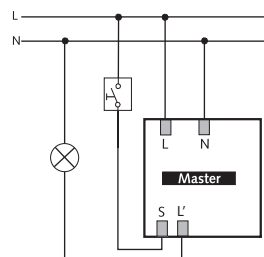

thePiccola P360-100 DE WH

# Presence and motion detectors

## Presence detectors, 230 V AC



### Description

#### Common functions

- Presence detector (PIR)
- Lighting control with adjustable light threshold value and adjustable switch-off delay
- Teach-in of current brightness value possible via remote control
- Additional pulse function can be selected for combination with staircase timer (ELPA), building automation or PLC
- Master/slave function: Up to ten detectors to expand detection area
- Test function for checking detection area
- Zero-cross switching

- Automatic lighting control based on presence and brightness
- Detection area can be limited using three enclosed segments
- Mixed light measurement suitable for the control of fluorescent, incandescent and halogen lamps
- Instant start-up possible via factory preset
- Push-button or switch options for manual switching
- Screwless terminals for quick installation

#### SPHINX 104-360 AP

- 1 channel
- Surface-mounted installation

#### SPHINX 104-360/2 AP

- 2 channels
- Surface-mounted installation
- 2. Relay for HVAC control, presence dependent
- HVAC control with programmable switch-on and switch-off delay

#### SPHINX 104-360

- 1 channel
- Flush-mounted installation

#### SPHINX 104-360/2

- As SPHINX 104-360/2 AP, but:
- Flush-mounted installation

### Product selection

Installation type	Channel	Detection angle	Colour	Type	Article number
Ceiling installation, Surface mounted	Light	360°	Pure white (similar to RAL 9010)	SPHINX 104-360 AP	1040360
	Light   Presence	360°	Pure white (similar to RAL 9010)	SPHINX 104-360/2 AP	1040362
Ceiling installation	Light	360°	Pure white (similar to RAL 9010)	SPHINX 104-360	1040370
	Light   Presence	360°	Pure white (similar to RAL 9010)	SPHINX 104-360/2	1040372

### Technical data

	SPHINX 104-360 AP	SPHINX 104-360/2 AP	SPHINX 104-360	SPHINX 104-360/2
Operating voltage	230 V AC			
Frequency	50–60 Hz			
Stand-by consumption	1 W			
Setting range brightness	10–2000 lx			
Switching capacity light	16 A (at 230 V AC, cos φ = 1)		8 A (at 230 V AC, cos φ = 1)	
Switching capacity presence	–	5 A (cos φ = 1) 250 V AC/30 V DC	–	3 A (cos φ = 1) 250 V AC/30 V DC
Detection angle	360°			
Installation height	2,5–3,5 m			
Light switch-off delay	1 s–20 min			
Presence switch-off delay	–	1–120 min	–	1–120 min

# Presence and motion detectors

## Presence detectors, 230 V AC

	SPHINX 104-360 AP	SPHINX 104-360/2 AP	SPHINX 104-360	SPHINX 104-360/2
Switch-on delay presence	–	0–60 min	–	0–60 min
Incandescent lamp load	2000 W		1800 W	
Fluorescent lamp load (conventional) not corrected	900 VA			
Fluorescent lamp load (conventional) parallel-corrected	400 VA, 42 µF			
Fluorescent lamp load (conventional) series-corrected	900 VA			
Fluorescent lamp load (conventional) lead-lag circuit	900 VA			
Energy saving lamps	4 x 7 W, 3 x 11 W, 3 x 15 W, 3 x 20 W, 3 x 23 W			
LED lamp < 2 W	25 W			
LED lamp > 2 W	90 W			
Ambient temperature	–10 °C ... +55 °C			
Protection class	II			
Type of protection	IP 41 (when fitted)			

### Detection range (Round)

Mounting height	Sitting	Walking diagonally	Walking head on to
2 m	4 m	9 m	6 m
2,5 m	5 m	12 m	6 m
3 m	5 m	12 m	6 m
3,5 m	6 m	14 m	7 m
4 m	5 m	12 m	6 m

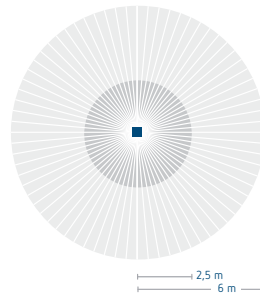

### Accessories

#### RC filter

Details page 339

#### SPHINX RC 104 Pro

Details page 341

#### SPHINX RC 104

Details page 341

7

### Scale drawings

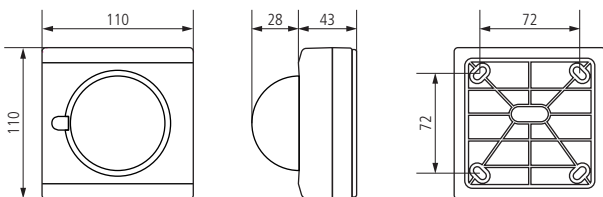

SPHINX 104-360 AP, SPHINX 104-360/2 AP

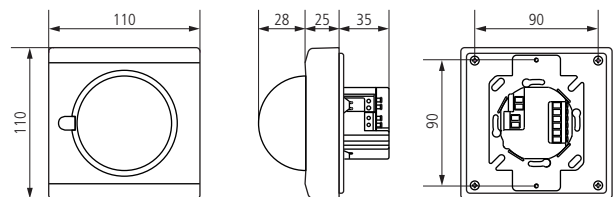

SPHINX 104-360, SPHINX 104-360/2

### Connection diagrams

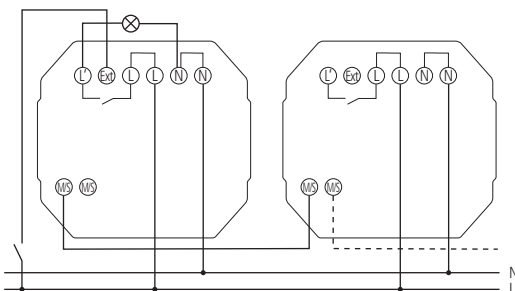

SPHINX 104-360 AP, SPHINX 104-360

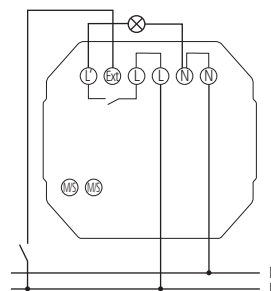

SPHINX 104-360 AP,  
SPHINX 104-360

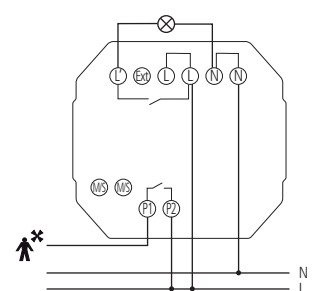

SPHINX 104-360/2 AP,  
SPHINX 104-360/2

# Presence and motion detectors

## Presence detectors, 230 V AC



### Description

- Presence detector (PIR)
- 2 channels for application areas class and conference rooms
- Flush-mounted installation
- Channel 2 presence dependent, e.g. for blackboard lighting with programmable switch-off delay or for HVAC control
- Channel 1 for constant light control (1-10 V)
- Lighting control with adjustable light threshold value and adjustable switch-off delay
- Additional pulse function can be selected for combination with staircase timer (ELPA), building automation or PLC
- Test function for checking detection area
- Zero-cross switching
- Automatic lighting control based on presence and brightness
- Detection area can be limited using three enclosed segments
- Mixed light measurement suitable for the control of fluorescent, incandescent and halogen lamps
- Instant start-up possible via factory preset
- Push-button or for manual switching
- Fully or semi-automatic: In „Fully automatic“ mode, the lighting switches on and off automatically according to presence and light In „Semi-automatic“ mode, it must be switched on manually and it switches off automatically

### Product selection

Installation type	Channel	Detection angle	Colour	Type	Article number
Ceiling installation	Light   Presence	360°	Pure white (similar to RAL 9010)	SPHINX 104-360/2 DIMplus	1040374

7

### Technical data

SPHINX 104-360/2 DIMplus			
Operating voltage	230 V AC	Fluorescent lamp load (conventional) not corrected	900 VA
Frequency	50–60 Hz	Fluorescent lamp load (conventional) not corrected (channel presence)	200 VA
Stand-by consumption	1 W	Fluorescent lamp load (conventional) series-corrected	900 VA
Setting range brightness	5–2000 lx	Fluorescent lamp load (conventional) series-corrected (channel presence)	200 VA
Switching capacity light	4 A (at 230 V AC, cos φ = 1)	Fluorescent lamp load (electronic ballast) (channel presence)	60 VA
Switching capacity presence	2 A (cos φ = 1) μ, 250 V AC/30 V DC	Energy saving lamps	4 x 7 W, 3 x 11 W, 3 x 15 W, 3 x 20 W, 3 x 23 W
Detection angle	360°	Energy saving lamps (channel presence)	2 x 7 W, 2 x 11 W, 1 x 15 W, 1 x 20 W, 1 x 23 W
Installation height	2,5–3,5 m	LED lamp < 2 W	25 W
Switching output	Not potential-free (230 V)	LED lamp > 2 W	90 W
Switching output channel presence	Potential-free	Ambient temperature	-10 °C ... +55 °C
Light switch-off delay	1 s–20 min	Protection class	II
Presence switch-off delay	1–120 min	Type of protection	IP 40 (when fitted)
Incandescent lamp load	1000 W		
Incandescent lamp load (channel presence)	400 W		

### Detection range (Round)

Mounting height	Sitting	Walking diagonally	Walking head on to
2 m	4 m	18 m	9 m
2,5 m	6 m	24 m	12 m
3 m	6 m	24 m	12 m
3,5 m	8 m	26 m	13 m
4 m	6 m	24 m	12 m

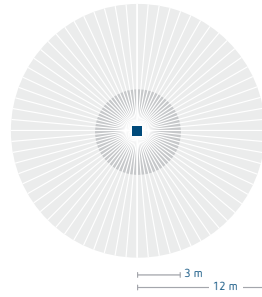

### Scale drawings

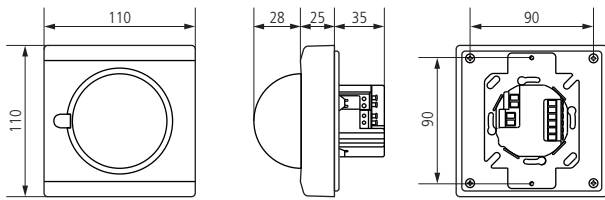

### Connection diagrams

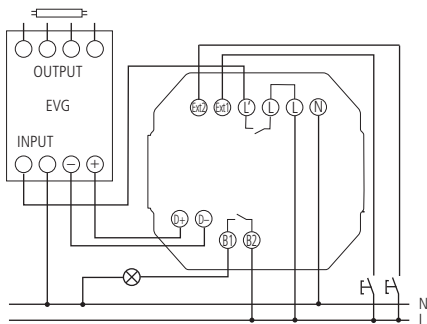

### Accessories

7



RC filter  
↳ Art.No.: 9070523  
Details page 339

# Presence and motion detectors

## Presence detectors, 230 V AC



### Description

- Passive infra-red presence detector for ceiling installation
- Circular detection area 360°, up to Ø 9 m (64 m²)
- Mixed light measurement suitable for fluorescent lamps (FL/PL/ESL), halogen/ incandescent lamps and LEDs
- Channel A light: relay, 230 V
- Operation as fully automatic device
- Brightness switching value configurable, teach-in function
- Pulse function for staircase light time switch
- Time delay configurable
- Detection sensitivity configurable
- Test mode for checking function and detection area
- Ready for immediate use due to factory presetting (Brightness switching value 300 lux, Time delay 10 min)
- One of these optional remote controls is required for changing the values and attitudes:
  - Management remote control SendoPro
  - Installation remote control theSenda P
- Optional user remote control:
  - theSenda S

#### theRonda S360-100 DE

- Automatic motion and brightness-dependent control for lighting

#### theRonda S360-101 DE

- Automatic motion and brightness-dependent control for lighting and HVAC
- Channel H, presence: relay, floating e.g. for HVAC control

7

### Product selection

Installation type	Channel	Operating voltage	Colour	Type	Article number
Ceiling installation	Light	230 V AC	White	theRonda S360-100 DE WH	2080560
			Grey	theRonda S360-100 DE GR	2080561
	Light   Presence	230 V AC	White	theRonda S360-101 DE WH	2080565
			Grey	theRonda S360-101 DE GR	2080566

### Technical data

	theRonda S360-100 DE	theRonda S360-101 DE
Operating voltage	230 V AC	
Frequency	50 Hz	
Installation height	2–4 m	
Minimum height	> 1,7 m	
Setting range brightness	30–3000 lx	
Light switch-off delay	10 s–60 min	
Incandescent/halogen lamp load	2300 W	
Inrush current	max. 400 A/200 µs	
LED lamp < 2 W	25 W	
LED lamp 2–8 W	70 W	
LED lamp > 8 W	80 W	
Switching capacity presence	–	50 W/50 VA, max. 2 A
Ambient temperature	–15 °C ... +50 °C	
Type of protection	IP 54 (when fitted)	

Detection range (Round)

Mounting height (A)	Walking (T)	Sitting (S)
2 m	38 m <sup>2</sup>   7 m	5 m <sup>2</sup>   2,5 m
2,5 m	38 m <sup>2</sup>   7 m	7 m <sup>2</sup>   3 m
3 m	50 m <sup>2</sup>   8 m	13 m <sup>2</sup>   4 m
3,5 m	50 m <sup>2</sup>   8 m	–
4 m	64 m <sup>2</sup>   9 m	–

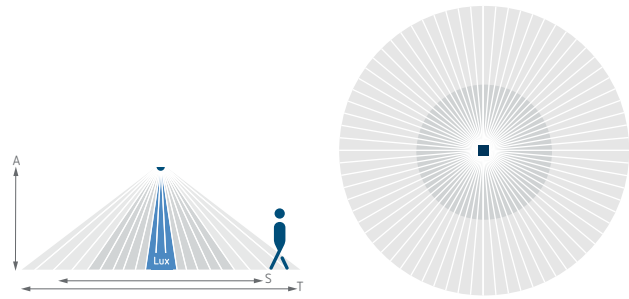

Accessories



SendoPro 868-A  
↳ Art.No.: 9070675  
Details page 339



theSenda P  
↳ Art.No.: 9070910  
Details page 341



theSenda S  
↳ Art.No.: 9070911  
Details page 341

Scale drawings

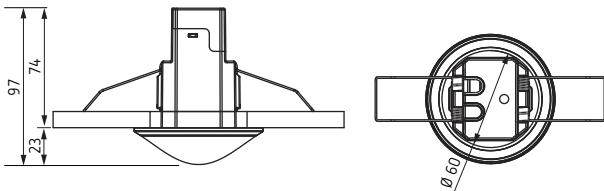

Connection diagrams

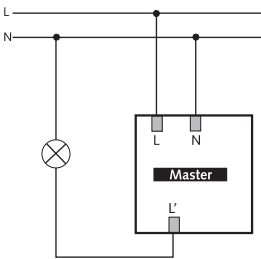

theRonda S360-100 DE

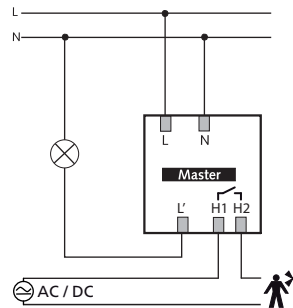

theRonda S360-101 DE

# Presence and motion detectors

## Presence detectors, 230 V AC



### Description

- Passive infra-red presence detector for ceiling installation
  - Circular detection area 360°, up to Ø 9 m (64 m<sup>2</sup>)
  - Mixed light measurement suitable for fluorescent lamps (FL/PL/ESL), halogen/ incandescent lamps and LEDs
  - Channel A light: relay, 230 V
  - Operation as fully automatic device
  - Brightness switching value configurable, teach-in function
  - Pulse function for staircase light time switch
  - Time delay configurable
  - Detection sensitivity configurable
  - Test mode for checking function and detection area
  - Ready for immediate use due to factory presetting (Brightness switching value 300 lux, Time delay 10 min)
  - One of these optional remote controls is required for changing the values and attitudes:
    - Management remote control SendoPro
    - Installation remote control theSenda P
  - Optional user remote control:
    - theSenda S
- theRonda S360-100 AP
- Automatic motion and brightness-dependent control for lighting
- theRonda S360-101 AP
- Automatic motion and brightness-dependent control for lighting and HVAC
  - Channel H, presence: relay, floating e.g. for HVAC control

### Product selection

Installation type	Channel	Operating voltage	Colour	Type	Article number
Ceiling installation	Light	230 V AC	White	theRonda S360-100 AP WH	2080550
			Grey	theRonda S360-100 AP GR	2080551
	Light   Presence	230 V AC	White	theRonda S360-101 AP WH	2080555
			Grey	theRonda S360-101 AP GR	2080556

### Technical data

	theRonda S360-100 AP	theRonda S360-101 AP
Operating voltage	230 V AC	
Frequency	50 Hz	
Installation height	2–4 m	
Minimum height	> 1,7 m	
Setting range brightness	30–3000 lx	
Light switch-off delay	10 s–60 min	
Incandescent/halogen lamp load	2300 W	
Inrush current	max. 400 A/200 µs	
LED lamp < 2 W	25 W	
LED lamp 2–8 W	70 W	
LED lamp > 8 W	80 W	
Switching capacity presence	–	50 W/50 VA, max. 2 A
Ambient temperature	–15 °C ... +50 °C	
Type of protection	IP 54	

7

Detection range (Round)

Mounting height (A)	Walking (T)	Sitting (S)
2 m	38 m <sup>2</sup>   7 m	5 m <sup>2</sup>   2,5 m
2,5 m	38 m <sup>2</sup>   7 m	7 m <sup>2</sup>   3 m
3 m	50 m <sup>2</sup>   8 m	13 m <sup>2</sup>   4 m
3,5 m	50 m <sup>2</sup>   8 m	–
4 m	64 m <sup>2</sup>   9 m	–

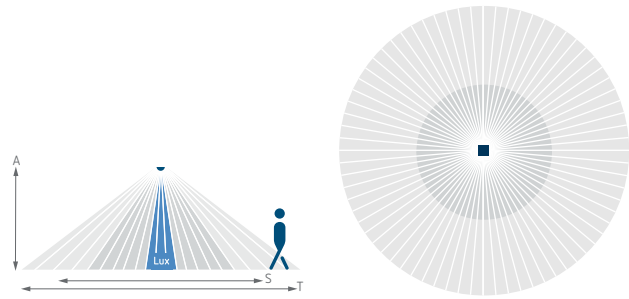

Accessories



SendoPro 868-A  
↳ Art.No.: 9070675  
Details page 339



theSenda P  
↳ Art.No.: 9070910  
Details page 341



theSenda S  
↳ Art.No.: 9070911  
Details page 341

Scale drawings

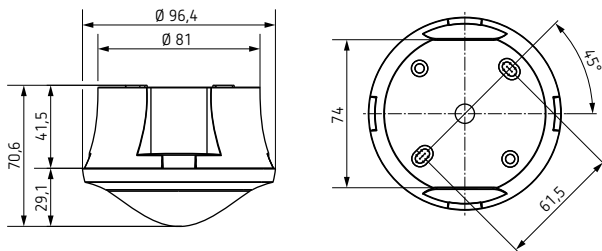

Connection diagrams

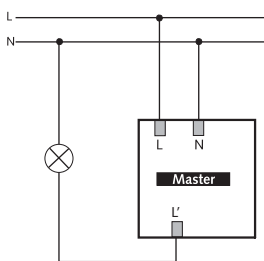

theRonda S360-100 AP

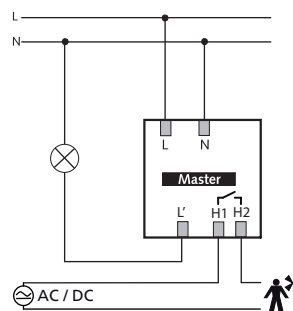

theRonda S360-101 AP

# Presence and motion detectors

## Presence detectors, 230 V AC



### Description

#### Common functions

- Passive infra-red presence detector for ceiling installation
- Circular detection area 360°, up to Ø 9 m (64 m²)
- Automatic motion and brightness-dependent control for lighting
- Mixed light measurement suitable for fluorescent lamps (FL/PL/ESL), halogen/ incandescent lamps and LEDs
- Channel A light: relay, 230 V
- Operation as fully automatic device
- Brightness switching value configurable, teach-in function

- Pulse function for staircase light time switch
- Time delay configurable
- Detection sensitivity configurable
- Test mode for checking function and detection area
- Ready for immediate use due to factory presetting (Brightness switching value 300 lux, Time delay 10 min)
- One of these optional remote controls is required for changing the values and attitudes:
  - Management remote control SendaPro
  - Installation remote control theSenda P
  - Optional user remote control: theSenda S

#### theRonda S360-100 WH GST

- Presence detector (PIR), with pre-configured cable and Wieland GSTi18 connector, cable length 1.50 meter

#### theRonda S360-100 WH WINSTA

- Presence detector (PIR), with pre-configured cable and WAGO WINSTA Midi connector, cable length 1.50 meter

### Product selection

Installation type	Channel	Operating voltage	Colour	Type	Article number
Ceiling installation	Light	230 V AC	White	theRonda S360-100 WH GST	2080570
				theRonda S360-100 WH WINSTA	2080575

### Technical data

	theRonda S360-100 WH GST	theRonda S360-100 WH WINSTA
Operating voltage	230 V AC	
Frequency	50 Hz	
Installation height	2 – 4 m	
Minimum height	> 1,7 m	
Setting range brightness	30 – 3000 lx	
Light switch-off delay	10 s – 60 min	
Incandescent/halogen lamp load	2300 W	
Inrush current	max. 400 A / 200 µs	
LED lamp < 2 W	25 W	

# Presence and motion detectors

## Presence detectors, 230 V AC

	theRonda S360-100 WH GST	theRonda S360-100 WH WINSTA
LED lamp 2–8 W	70 W	
LED lamp > 8 W	80 W	
Ambient temperature	–15 °C ... +50 °C	
Type of protection	IP 54 (when fitted)	

### Detection range (Round)

Mounting height (A)	Walking (T)	Sitting (S)
2 m	38 m <sup>2</sup>   7 m	5 m <sup>2</sup>   2,5 m
2,5 m	38 m <sup>2</sup>   7 m	7 m <sup>2</sup>   3 m
3 m	50 m <sup>2</sup>   8 m	13 m <sup>2</sup>   4 m
3,5 m	50 m <sup>2</sup>   8 m	–
4 m	64 m <sup>2</sup>   9 m	–

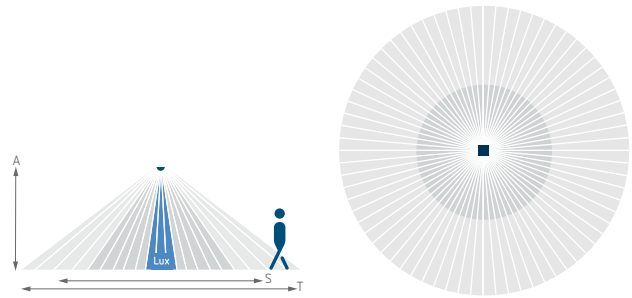

### Accessories



SendoPro 868-A  
↳ Art.No.: 9070675  
Details page 339



theSenda P  
↳ Art.No.: 9070910  
Details page 341



theSenda S  
↳ Art.No.: 9070911  
Details page 341

7

### Scale drawings

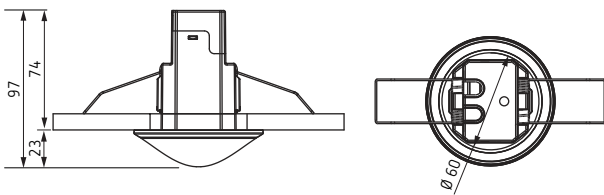

### Connection diagrams

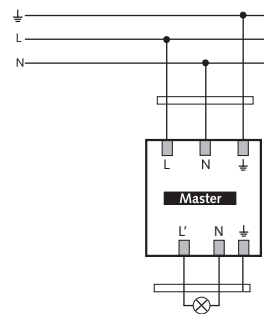

# Presence and motion detectors

## Presence detectors, 230 V AC



### Description

- Passive infrared presence detector for ceiling mounting
  - Round detection area 360°, up to Ø 24 m (452 m²)
  - Mixed light measurement suitable for fluorescent lamps (FL/PL/ESL), halogen/ incandescent lamps and LEDs
  - Channel A, light: relay, 230V
  - Choice of fully or semi-automatic operation
  - Adjustable brightness switching value, teach-in function
  - Reduction of switch-off delay time in the event of short presence (brief-presence)
  - Connection option for sensors or switches for manual switching with automatic recognition of sensor/switch
  - Pulse function for staircase light time switch
  - Switch-on delay and switch-off delay configurable
  - Sensitivity adjustable
  - Detection area can be limited using cover clip
  - Ready for immediate use due to factory preset
  - Test mode for checking function and detection area
  - Extension of detection area via Master/Slave or Master/Master switching, a maximum of 10 detectors can be switched in parallel with each other
  - Ceiling installation in flush-mounted socket
  - Ceiling installation also possible with surface-mounted frame
  - User remote control theSenda S, management remote control SendaPro (optional)
- theRonda P360-100 M
- Automatic presence- and brightness-dependent control for lighting
- theRonda P360-101 M
- Automatic presence- and brightness-dependent control for lighting and HVAC
  - Channel H, presence: relay, floating
  - e.g. for HVAC control
- theRonda P360 Slave
- Slave version for theRonda P360 M
  - Just to be used with theRonda P360 M as Master

7

### Product selection

Installation type	Channel	Operating voltage	Colour	Type	Article number
Ceiling installation	Light	110–230 V AC	White	theRonda P360-100 M UP WH	2080020
			Grey	theRonda P360-100 M UP GR	2080021
	Light   Presence	110–230 V AC	White	theRonda P360-101 M UP WH	2080025
			Grey	theRonda P360-101 M UP GR	2080026
	Slave	110–230 V AC	White	theRonda P360 Slave UP WH	2080030
			Grey	theRonda P360 Slave UP GR	2080031

### Technical data

	theRonda P360-100 M UP	theRonda P360-101 M UP	theRonda P360 Slave UP
Operating voltage	110–230 V AC		
Frequency	50–60 Hz		
Installation height	2–10 m		
Minimum height	> 1,7 m		
Power consumption	0,15 W		
Setting range brightness	30–3000 lx		–
Light switch-off delay	10 s–60 min		–
Incandescent/halogen lamp load	2300 W		–
Compact and fluorescent lamps	1150 VA (cos φ = 0,5)		–
Inrush current	max. 800 A/200 μs		–
LED lamp < 2 W	60 W		–
LED lamp 2–8 W	180 W		–

# Presence and motion detectors

## Presence detectors, 230 V AC

	theRonda P360-100 M UP	theRonda P360-101 M UP	theRonda P360 Slave UP
LED lamp > 8 W	200 W		-
Switch-on delay presence	-	0 s – 10 min	-
Presence switch-off delay	-	10 s – 120 min	-
Switching capacity presence	-	50 W / 50 VA	-
Size of concealed housing	Ø 55 mm (NIS, PMI)		
Ambient temperature	-15 °C ... +50 °C		
Type of protection	IP 54 (when fitted)		

### Detection range (Round)

Mounting height (A)	Sitting (S)	Walking diagonally (T)	Walking head on to
2 m	16 m²   4,5 m	380 m²   22 m	28 m²   6 m
2,5 m	24 m²   5,5 m	415 m²   23 m	38 m²   7 m
3 m	28 m²   6 m	452 m²   24 m	50 m²   8 m
3,5 m	38 m²   7 m	452 m²   24 m	50 m²   8 m
6 m	-	452 m²   24 m	50 m²   8 m
10 m	-	491 m²   25 m	50 m²   8 m

With a mounting height of more than 3.5 m walking motions are necessary and the detection areas of several detectors should overlap in the marginal zone. All figures are up to values. The detection range decreases with increasing temperatures.

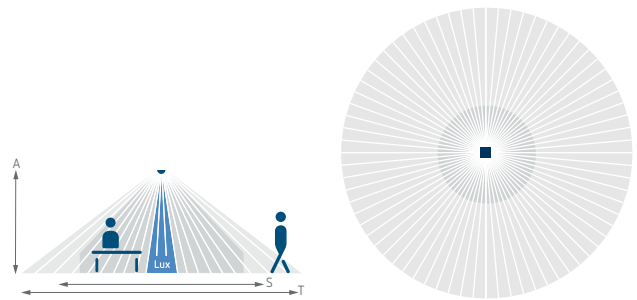

7

### Accessories



**SendoPro 868-A**  
↳ Art.No.: 9070675  
Details page 339



**theSenda P**  
↳ Art.No.: 9070910  
Details page 341



**theSenda S**  
↳ Art.No.: 9070911  
Details page 341

**QuickSafe**  
Details page 338

**Surface frame 110A WH**  
Details page 337

**Surface frame 110A GR**  
Details page 337

**Ceiling installation box 73A**  
Details page 337

**Masking clip**  
Details page 337

### Scale drawings

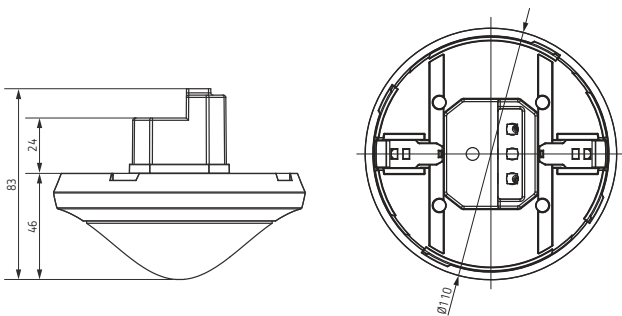

### Connection diagrams

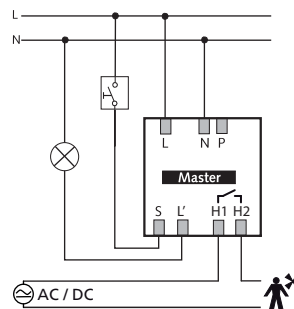

theRonda P360-101 M UP

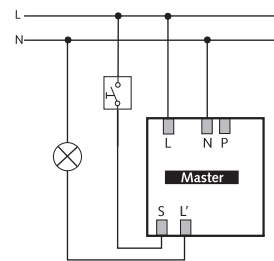

theRonda P360-100 M UP

# Presence and motion detectors

## Presence detectors, 230 V AC



### Description

#### Common functions

- Passive infrared presence detector for ceiling mounting
- Round detection area 360°, up to Ø 24 m (452 m<sup>2</sup>)
- Automatic presence- and brightness-dependent control for lighting
- Mixed light measurement suitable for fluorescent lamps (FL/PL/ESL), halogen/ incandescent lamps and LEDs
- Channel A, light: relay, 230 V
- Choice of fully or semi-automatic operation
- Adjustable brightness switching value, teach-in function

- Reduction of switch-off delay time in the event of short presence (brief-presence)
- Connection option for sensors or switches for manual switching with automatic recognition of sensor/switch
- Pulse function for staircase light time switch
- Sensitivity adjustable
- Detection area can be limited using cover clip
- Ready for immediate use due to factory preset
- Test mode for checking function and detection area

- Ceiling installation in flush-mounted socket
- Ceiling installation also possible with surface-mounted frame
- User remote control theSenda S, management remote control SendoPro (optional)

#### theRonda P360-100 WH GST

- Presence detector (PIR), with pre-configured cable and Wieland GSTi18 connector, cable length 1.50 meter

#### theRonda P360-100 WH WINSTA

- Presence detector (PIR), with pre-configured cable and WAGO WINSTA Midi connector, cable length 1.50 meter

### Product selection

Installation type	Channel	Operating voltage	Colour	Type	Article number
Ceiling installation	Light	110–230 V AC	White	theRonda P360-100 WH GST	2080010
				theRonda P360-100 WH WINSTA	2080015

### Technical data

	theRonda P360-100 WH GST	theRonda P360-100 WH WINSTA
Operating voltage	110–230 V AC	
Frequency	50–60 Hz	
Installation height	2–10 m	
Minimum height	> 1,7 m	
Power consumption	0,15 W	
Setting range brightness	30–3000 lx	
Light switch-off delay	10 s–60 min	
Incandescent/ halogen lamp load	2300 W	
Compact and fluorescent lamps	1150 VA (cos φ = 0,5)	
LED lamp < 2 W	60 W	

# Presence and motion detectors

## Presence detectors, 230 V AC

	theRonda P360-100 WH GST	theRonda P360-100 WH WINSTA
LED lamp 2–8 W	180 W	
LED lamp > 8 W	200 W	
Ambient temperature	–15 °C ... +50 °C	
Type of protection	IP 54 (when fitted)	

### Detection range (Round)

Mounting height (A)	Sitting (S)	Walking diagonally (T)	Walking head on to
2 m	16 m <sup>2</sup>   4,5 m	380 m <sup>2</sup>   22 m	28 m <sup>2</sup>   6 m
2,5 m	24 m <sup>2</sup>   5,5 m	415 m <sup>2</sup>   23 m	38 m <sup>2</sup>   7 m
3 m	28 m <sup>2</sup>   6 m	452 m <sup>2</sup>   24 m	50 m <sup>2</sup>   8 m
3,5 m	38 m <sup>2</sup>   7 m	452 m <sup>2</sup>   24 m	50 m <sup>2</sup>   8 m
6 m	–	452 m <sup>2</sup>   24 m	50 m <sup>2</sup>   8 m
10 m	–	491 m <sup>2</sup>   25 m	50 m <sup>2</sup>   8 m

With a mounting height of more than 3.5 m walking motions are necessary and the detection areas of several detectors should overlap in the marginal zone. All figures are up to values. The detection range decreases with increasing temperatures.

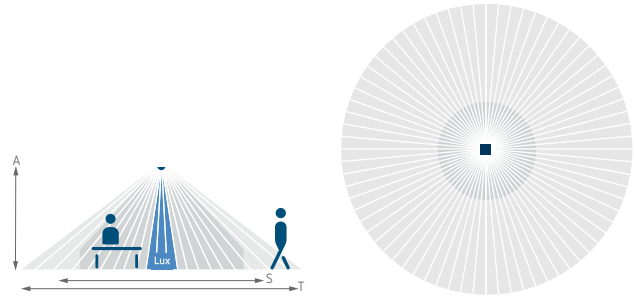

### Accessories



**SendoPro 868-A**  
↳ Art.No.: 9070675  
Details page 339



**theSenda P**  
↳ Art.No.: 9070910  
Details page 341



**theSenda S**  
↳ Art.No.: 9070911  
Details page 341

**Masking clip**  
Details page 337

**QuickSafe**  
Details page 338

### Scale drawings

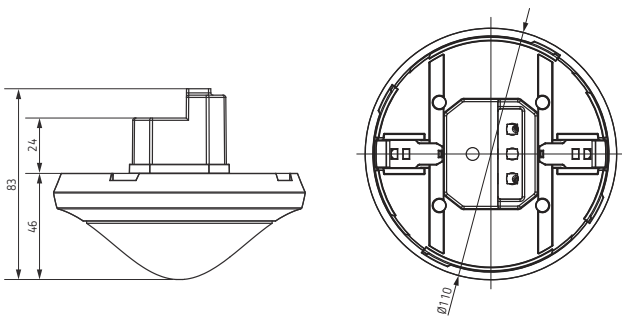

### Connection diagrams

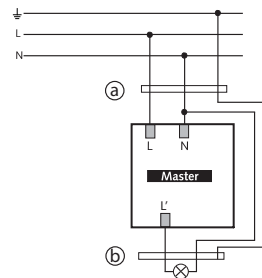

# Presence and motion detectors

## Presence detectors, 230 V AC

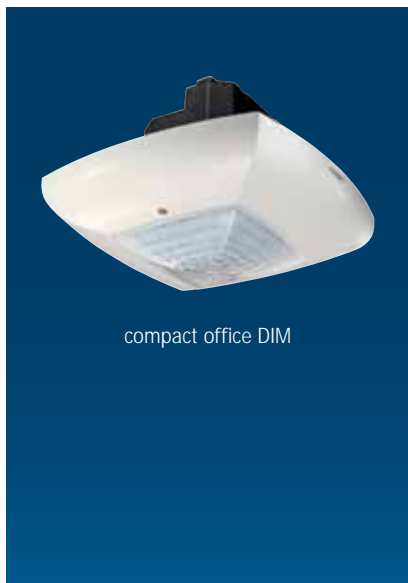

### Description

- Presence detector (PIR)
- Automatic control of lighting depending on presence and brightness
- Square detection area allows accurate and simple planning
- Light switching output (relay, 230 V) and 1–10 V interface
- Mixed light measurement, suitable for fluorescent lamps (FL/PL/ESL), halogen/ incandescent lamps and LEDs
- Brightness threshold, self-learning switch-off delay and stand-by time adjustable
- The stand-by time guarantees a minimum brightness and provides for a sense of security in hospital and care environments as the lighting does not switch off when areas are unoccupied but remains in stand-by mode for the set time
- Choice of fully or semi automatic operation: In „Semi-automatic“ (absence detection) mode the light must be switched on manually and switches off automatically
- Parameters can be set using the potentiometers or via the optional service remote controls
- Optional user remote control
- Ready for use by ex-factory set items
- Test operation to check detection area and installation
- Master/slave or master/master parallel switching: Up to ten detectors can be connected with each other to extend the detection area
- Ceiling mounting in flush-mounted box
- Possibility of surface mounting by using a surface frame

### Product selection

Installation type	Channel	Operating voltage	Colour	Type	Article number
Ceiling installation	Light   1–10 V	230 V AC	Pure white (similar to RAL 9010)	compact office DIM	2010001

### Technical data

	compact office DIM
Operating voltage	230 V AC
Frequency	50 Hz
Installation height	2–3,5 m
Power consumption	0,8 W
Setting range brightness	Approx. 10–1500 lx/on
Light switch-off delay	10 s–20 min
Stand-by time light	0 s–60 min/on
Stand-by brightness	10 %
Type of contact light	Relay 230 V
Resistive load	1400 VA
Incandescent/halogen lamp load	1200 W
Compact and fluorescent lamps	960 VA (cos φ = 0,8), 580 VA (cos φ = 0,5)
Compact and fluorescent lamps (max. number of electronic ballasts)	10 x (1 x 54/58 W), 5 x (2 x 54/58 W), 16 x (1 x 35/36 W), 8 x (2 x 35/36 W), 16 x (smaller than 35/36 W)
Control output	1–10 V DC/100 mA as per EN 60929/A1
Size of concealed housing	Ø 55 mm (NIS, PMI)
Ambient temperature	0 °C ... +50 °C
Type of protection	IP 40 (when fitted)

Detection range (Square)

Mounting height (A)	Walking (T)	Sitting (S)
2 m	20 m <sup>2</sup>   4,5 m x 4,5 m ± 0,5 m	9 m <sup>2</sup>   3 m x 3 m
2,5 m	36 m <sup>2</sup>   6 m x 6 m ± 0,5 m	16 m <sup>2</sup>   4 m x 4 m
3 m	49 m <sup>2</sup>   7 m x 7 m ± 1 m	20 m <sup>2</sup>   4,5 m x 4,5 m
3,5 m	64 m <sup>2</sup>   8 m x 8 m ± 1 m	-

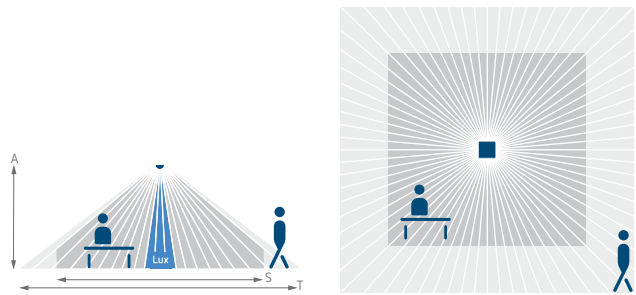

Accessories



Surface frame compact  
↳ Art.No.: 9070514  
Details page 337



SendoPro 868-A  
↳ Art.No.: 9070675  
Details page 339

Ceiling installation box 73A  
Details page 339

QuickSafe  
Details page 338

Scale drawings

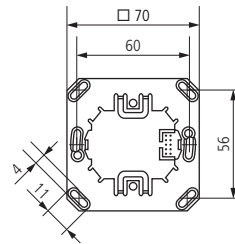
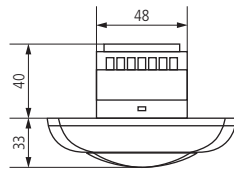
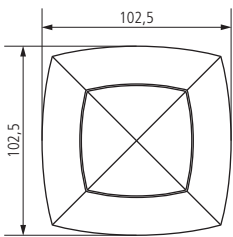

Connection diagrams

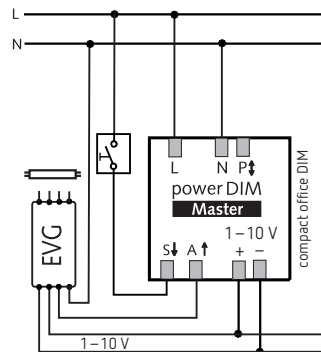
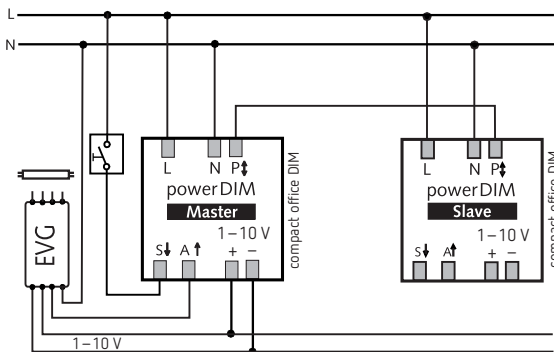

# Presence and motion detectors

## Presence detectors, 230 V AC



### Description

- Presence detector (PIR)
- Automatic control of lighting depending on presence and brightness
- Rectangular detection area for corridors allows accurate and simple planning
- Light switch output (relay, 230 V)
- Mixed light measurement, suitable for fluorescent lamps (FL/PL/ESL), halogen/incandescent lamps and LEDs
- Brightness threshold and self-learning switch-off delay adjustable
- Push button or switch connection for manual control
- Pulse function for staircase time switch
- Choice of fully or semi automatic operation: In „Semi-automatic“ (absence detection) mode the light must be switched on manually and switches off automatically
- Presence switch output (relay, potential-free) for example for HVAC control
- HVAC control with adjustable switch-on and switch-off delay
- Function „monitoring“ with reduced sensitivity only to detect walking persons
- Parameters can be set using the potentiometers or via the optional service remote controls
- Optional user remote control
- Ready for use by ex-factory set items
- Test operation to check detection area and installation
- Master/slave or master/master parallel switching: Up to ten detectors can be connected with each other to extend the detection area
- Ceiling mounting in flush-mounted box
- Possibility of surface mounting by using a surface frame

### Product selection

7

Installation type	Channel	Operating voltage	Colour	Type	Article number
Ceiling installation	Light   Presence	230 V AC	Pure white (similar to RAL 9010)	compact passage	2010090
			Black (similar to RAL 9005)	compact passage BK	2010806
			Silver (similar to RAL 9006)	compact passage SR	2010807

### Technical data

	compact passage
Operating voltage	230 V AC
Frequency	50 Hz
Installation height	2 – 6 m
Power consumption	0,7 W
Setting range brightness	Approx. 10 – 1500 lx/on
Light switch-off delay	Pulse (0,5 s), 10 s – 20 min
Type of contact light	Relay 230 V
Resistive load	1400 VA
Incandescent/halogen lamp load	1200 W
Compact and fluorescent lamps	960 VA (cos φ = 0,8), 580 VA (cos φ = 0,5)
Compact and fluorescent lamps (max. number of electronic ballasts)	10 x (1 x 54/58 W), 5 x (2 x 54/58 W), 16 x (1 x 35/36 W), 8 x (2 x 35/36 W), 16 x (smaller than 35/36 W)
LED lamp < 2 W	25 W
LED lamp 2 – 8	70 W
LED lamp > 8 W	80 W
Switch-on delay presence	0 s – 10 min
Presence switch-off delay	10 s – 120 min
Type of contact presence	Relay potential-free, 220 V DC/250 V AC
Switching capacity presence	50 W (220 V DC), 50 VA (250 V AC) min. 0,5 mV/10 mA
Size of concealed housing	Ø 55 mm (NIS, PMI)
Ambient temperature	0 °C ... +50 °C
Type of protection	IP 40 (when fitted)

Detection range (Rectangular)

Mounting height (A)	Head on to (r)	Diagonally (t)
2 m	56 m <sup>2</sup>   16 m x 3,5 m ± 1,5 m	56 m <sup>2</sup>   16 m x 3,5 m ± 1,5 m
2,5 m	72 m <sup>2</sup>   18 m x 4 m ± 1,5 m	88 m <sup>2</sup>   22 m x 4 m ± 1,5 m
3 m	90 m <sup>2</sup>   20 m x 4,5 m ± 1,5 m	135 m <sup>2</sup>   30 m x 4,5 m ± 1,5 m
3,5 m	100 m <sup>2</sup>   20 m x 5 m ± 1,5 m	150 m <sup>2</sup>   30 m x 5 m ± 1,5 m
4 m	100 m <sup>2</sup>   20 m x 5 m ± 2 m	150 m <sup>2</sup>   30 m x 5 m ± 2 m
4,5 m	100 m <sup>2</sup>   20 m x 5 m ± 2 m	150 m <sup>2</sup>   30 m x 5 m ± 2 m
5 m	100 m <sup>2</sup>   20 m x 5 m ± 2,5 m	150 m <sup>2</sup>   30 m x 5 m ± 2,5 m
6 m	100 m <sup>2</sup>   20 m x 5 m ± 2,5 m	150 m <sup>2</sup>   30 m x 5 m ± 2,5 m

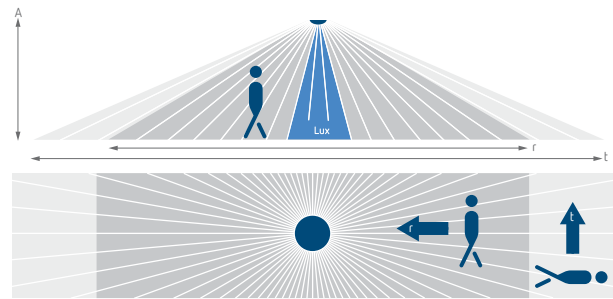

Accessories



Surface frame compact  
↳ Art.No.: 9070514  
Details page 337



SendoPro 868-A  
↳ Art.No.: 9070675  
Details page 339

QuickSafe

Details page 338

Surface frame compact BK

Details page 337

Surface frame compact SR

Details page 337

Ceiling installation box 73A

Details page 337

Scale drawings

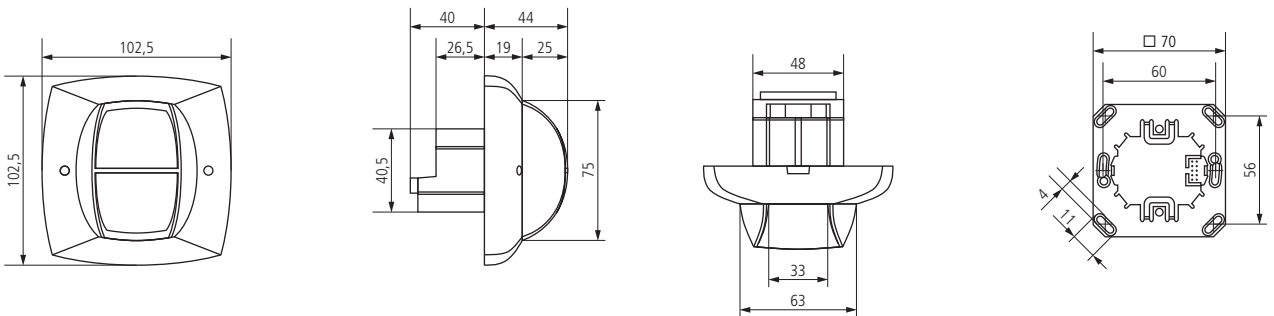

Connection diagrams

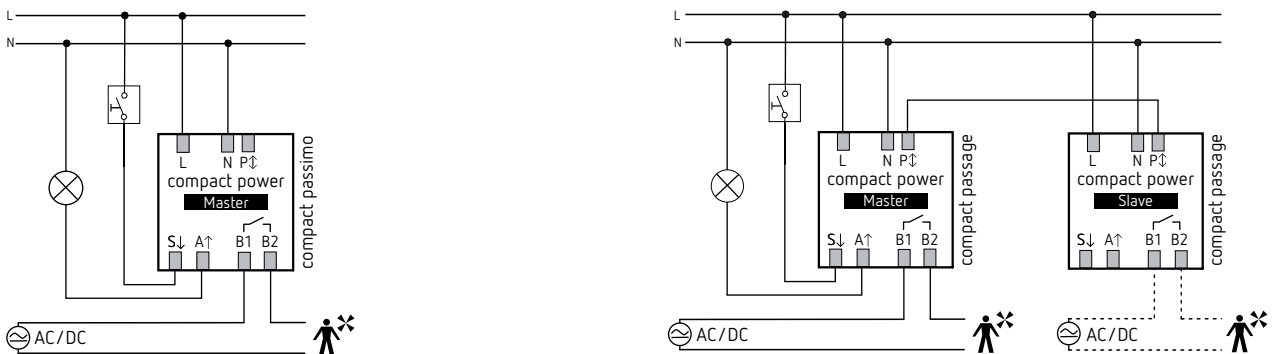

# Presence and motion detectors

## Presence detectors, 230 V AC



compact passage GST

compact passage WINSTA

### Description

#### Common functions

- Presence detector (PIR)
- Automatic control of lighting depending on presence and brightness
- Rectangular detection area for corridors allows accurate and simple planning
- Light switch output (relay, 230 V)
- Mixed light measurement, suitable for fluorescent lamps (FL/PL/ESL), halogen/incandescent lamps and LEDs
- Brightness threshold and self-learning switch-off delay adjustable
- Push button or switch connection for manual control
- Pulse function for staircase time switch

- Choice of fully or semi automatic operation: In „Semi-automatic“ (absence detection) mode the light must be switched on manually and switches off automatically
- Presence switch output (relay, potential-free) for example for HVAC control
- HVAC control with adjustable switch-on and switch-off delay
- Function „monitoring“ with reduced sensitivity only to detect walking persons
- Parameters can be set using the potentiometers or via the optional service remote controls
- Optional user remote control
- Ready for use by ex-factory set items

- Test operation to check detection area and installation

- Master/slave or master/master parallel switching: Up to ten detectors can be connected with each other to extend the detection area

#### theRonda P360-100 WH GST

- Presence detector (PIR), with pre-configured cable and Wieland GSTi18 connector, cable length 1.50 meter

#### theRonda P360-100 WH WINSTA

- Presence detector (PIR), with pre-configured cable and WAGO WINSTA Midi connector, cable length 1.50 meter

### Product selection

Installation type	Channel	Operating voltage	Colour	Type	Article number
Ceiling installation	Light   Presence	230 V AC	Pure white (similar to RAL 9010)	compact passage GST	2010100
				compact passage WINSTA	2010105

### Technical data

	compact passage
Operating voltage	230 V AC
Frequency	50 Hz
Installation height	2 – 6 m
Power consumption	0,7 W
Setting range brightness	Approx. 10 – 1500 lx/on
Light switch-off delay	Pulse (0,5 s), 10 s – 20 min
Type of contact light	Relay 230 V
Resistive load	1400 VA
Incandescent/halogen lamp load	1200 W
Compact and fluorescent lamps	960 VA (cos φ = 0,8), 580 VA (cos φ = 0,5)

# Presence and motion detectors

## Presence detectors, 230 V AC

	compact passage
Compact and fluorescent lamps (max. number of electronic ballasts)	10 x (1 x 54/58 W), 5 x (2 x 54/58 W), 16 x (1 x 35/36 W), 8 x (2 x 35/36 W), 16 x (smaller than 35/36 W)
LED lamp < 2 W	25 W
LED lamp 2–8	70 W
LED lamp > 8 W	80 W
Switch-on delay presence	0 s–10 min
Presence switch-off delay	10 s–120 min
Type of contact presence	Relay potential-free, 220 V DC/250 V AC
Switching capacity presence	50 W (220 V DC), 50 VA (250 V AC) min. 0,5 mV/10 mA
Ambient temperature	0 °C ... +50 °C
Type of protection	IP 40 (when fitted)

### Detection range (Rectangular)

Mounting height (A)	Head on to (r)	Diagonally (t)
2 m	56 m <sup>2</sup>   16 m x 3,5 m ± 1,5 m	56 m <sup>2</sup>   16 m x 3,5 m ± 1,5 m
2,5 m	72 m <sup>2</sup>   18 m x 4 m ± 1,5 m	88 m <sup>2</sup>   22 m x 4 m ± 1,5 m
3 m	90 m <sup>2</sup>   20 m x 4,5 m ± 1,5 m	135 m <sup>2</sup>   30 m x 4,5 m ± 1,5 m
3,5 m	100 m <sup>2</sup>   20 m x 5 m ± 1,5 m	150 m <sup>2</sup>   30 m x 5 m ± 1,5 m
4 m	100 m <sup>2</sup>   20 m x 5 m ± 2 m	150 m <sup>2</sup>   30 m x 5 m ± 2 m
4,5 m	100 m <sup>2</sup>   20 m x 5 m ± 2 m	150 m <sup>2</sup>   30 m x 5 m ± 2 m
5 m	100 m <sup>2</sup>   20 m x 5 m ± 2,5 m	150 m <sup>2</sup>   30 m x 5 m ± 2,5 m
6 m	100 m <sup>2</sup>   20 m x 5 m ± 2,5 m	150 m <sup>2</sup>   30 m x 5 m ± 2,5 m

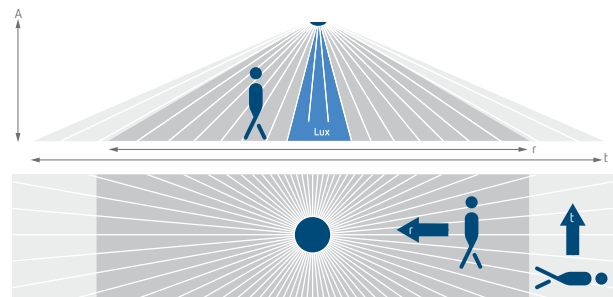

7

### Accessories



**SendoPro 868-A**  
↳ Art.No.: 9070675  
Details page 339



**QuickSafe**  
↳ Art.No.: 9070531  
Details page 338

### Scale drawings

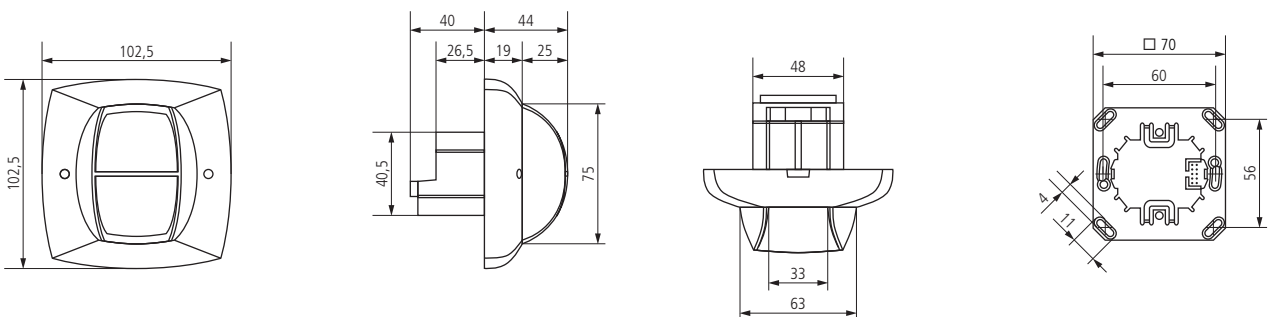

# Presence and motion detectors

## Presence detectors, 230 V AC



compact passimo

### Description

- Presence detector (PIR)
- Automatic control of lighting depending on presence and brightness
- Rectangular detection area for storage areas with clear demarcation vertically below the presence detector allows accurate and simple planning
- Light switch output (relay, 230 V)
- Mixed light measurement, suitable for fluorescent lamps (FL/PL/ESL), halogen/ incandescent lamps and LEDs
- Brightness threshold and self-learning switch-off delay adjustable
- Push button or switch connection for manual control
- Pulse function for staircase time switch
- Choice of fully or semi automatic operation: In „Semi-automatic“ (absence detection) mode the light must be switched on manually and switches off automatically
- Presence switch output (relay, potential-free) for example for HVAC control
- HVAC control with adjustable switch-on and switch-off delay
- Function „monitoring“ with reduced sensitivity only to detect walking persons
- Parameters can be set using the potentiometers or via the optional service remote controls
- Optional user remote control
- Ready for use by ex-factory set items
- Test operation to check detection area and installation
- Master/slave or master/master parallel switching: Up to ten detectors can be connected with each other to extend the detection area
- Ceiling mounting in flush-mounted box
- Possibility of surface mounting by using a surface frame

### Product selection

Installation type	Channel	Operating voltage	Colour	Type	Article number
Ceiling installation	Light   Presence	230 V AC	Pure white (similar to RAL 9010)	compact passimo WH	2010080
			Black (similar to RAL 9005)	compact passimo BK	2010809
			Silver (similar to RAL 9006)	compact passimo SR	2010810

### Technical data

	compact passimo
Operating voltage	230 V AC
Frequency	50 Hz
Installation height	2 – 6 m
Power consumption	0,7 W
Setting range brightness	Approx. 10 – 1500 lx/on
Light switch-off delay	Pulse (0,5 s), 10 s – 20 min
Type of contact light	Relay 230 V
Resistive load	1400 VA
Incandescent/halogen lamp load	1200 W
Compact and fluorescent lamps	960 VA (cos φ = 0,8), 580 VA (cos φ = 0,5)
Compact and fluorescent lamps (max. number of electronic ballasts)	10 x (1 x 54/58 W), 5 x (2 x 54/58 W), 16 x (1 x 35/36 W), 8 x (2 x 35/36 W), 16 x (smaller than 35/36 W)
LED lamp < 2 W	25 W
LED lamp 2 – 8	70 W
LED lamp > 8 W	80 W
Switch-on delay presence	0 s – 10 min
Presence switch-off delay	10 s – 120 min
Type of contact presence	Relay potential-free, 220 V DC/250 V AC
Switching capacity presence	50 W (220 V DC), 50 VA (250 V AC) min. 0,5 mV/10 mA
Size of concealed housing	Ø 55 mm (NIS, PMI)
Ambient temperature	0 °C ... +50 °C
Type of protection	IP 40 (when fitted)

7

Detection range (Rectangular)

Mounting height (A)	Head on to (r)	Diagonally (t)
2 m	28 m <sup>2</sup>   8 m x 3,5 m ± 1,5 m	28 m <sup>2</sup>   8 m x 3,5 m ± 1,5 m
2,5 m	36 m <sup>2</sup>   9 m x 4 m ± 1,5 m	44 m <sup>2</sup>   11 m x 4 m ± 1,5 m
3 m	45 m <sup>2</sup>   10 m x 4,5 m ± 1,5 m	68 m <sup>2</sup>   15 m x 4,5 m ± 1,5 m
3,5 m	50 m <sup>2</sup>   10 m x 5 m ± 1,5 m	75 m <sup>2</sup>   15 m x 5 m ± 1,5 m
4 m	50 m <sup>2</sup>   10 m x 5 m ± 2 m	75 m <sup>2</sup>   15 m x 5 m ± 2 m
4,5 m	50 m <sup>2</sup>   10 m x 5 m ± 2 m	75 m <sup>2</sup>   15 m x 5 m ± 2 m
5 m	50 m <sup>2</sup>   10 m x 5 m ± 2,5 m	75 m <sup>2</sup>   15 m x 5 m ± 2,5 m
6 m	50 m <sup>2</sup>   10 m x 5 m ± 2,5 m	75 m <sup>2</sup>   15 m x 5 m ± 2,5 m

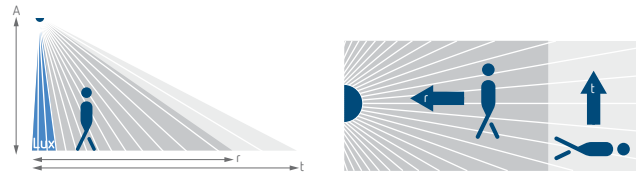

Accessories



Surface frame compact  
↳ Art.No.: 9070514  
Details page 337



SendoPro 868-A  
↳ Art.No.: 9070675  
Details page 339

QuickSafe

Details page 338

Surface frame compact BK

Details page 337

Surface frame compact SR

Details page 337

Ceiling installation box 73A

Details page 337

Scale drawings

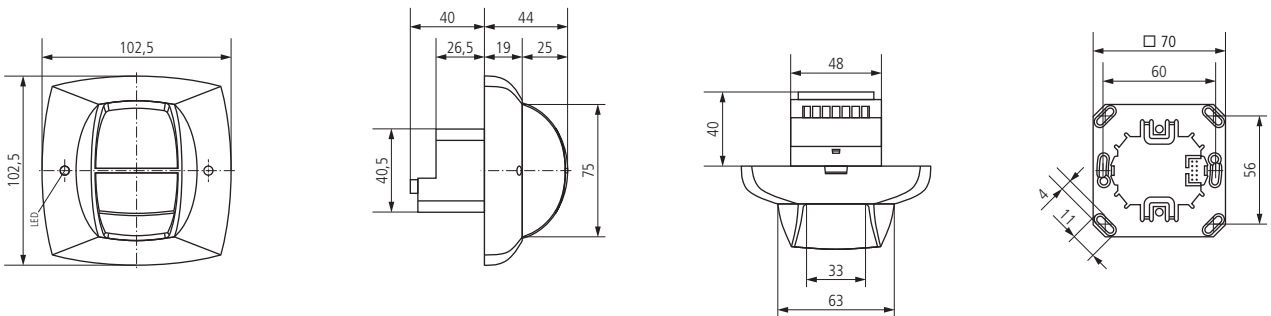

Connection diagrams

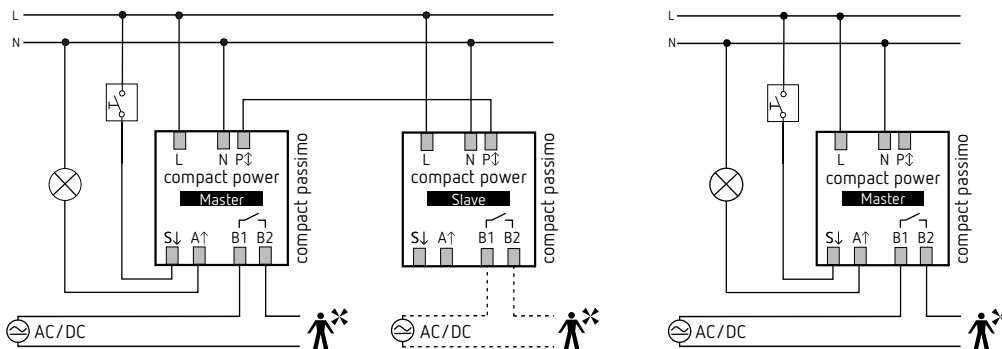

# Presence and motion detectors

## Presence detectors, 230 V AC

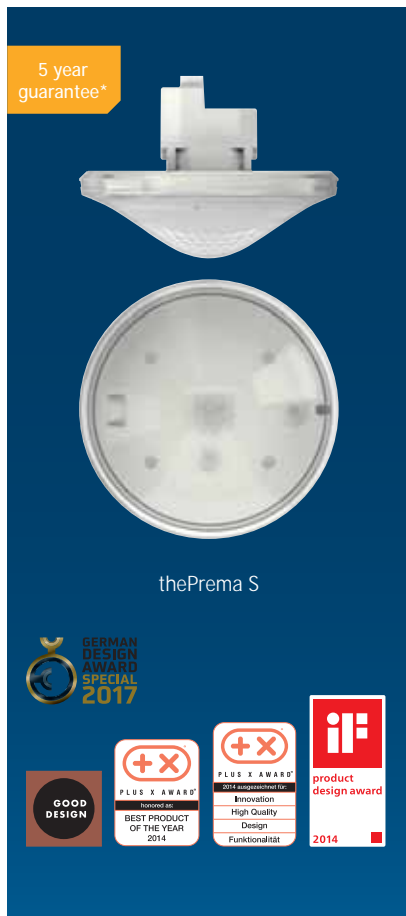

### Description

- Passive infrared presence detector for ceiling mounting
  - Square detection area 360° (up to 64 m²) for reliable and easy planning
  - Mixed light measurement suitable for fluorescent lamps (FL/PL/ESL), halogen/ incandescent lamps and LEDs
  - Choice of fully or semi-automatic (absence detection) operation
  - Adjustable brightness switching value, teach-in function
  - Self-learning time delay
  - Reduction of switch-off delay time in the event of short presence (brief-presence)
  - Connection option for sensors or switches for manual switching with automatic recognition of sensor/switch
  - Pulse function for staircase light time switch
  - Switch-on delay and switch-off delay configurable
  - Room monitoring with selective movement detection
  - Exceptionally easy configuration of the energy-saving behaviour with the new «eco plus» function
  - Staircase time function
  - User remote control theSenda S, management remote control SendoPro (optional)
  - Ready for immediate use due to factory preset
  - Test mode for checking function and detection area
  - Extension of detection area via Master/Slave or Master/Master switching, a maximum of 10 detectors can be switched in parallel with each other
  - Ceiling installation in flush-mounted socket
  - Ceiling installation also possible with surface-mounted frame
- thePrema S360-101 E**
- Automatic presence- and brightness-dependent control for lighting and HVAC
  - Channel A, light: relay, 230 V
  - Channel H, presence: relay, floating e.g. for HVAC control
  - Operating mode of light and presence relay can be flexibly selected using the remote control SendoPro
- thePrema S360-100 E**
- Automatic presence- and brightness-dependent control for lighting
  - Channel A, light: relay, 230V
- thePrema S360 Slave E**
- Slave version for thePrema
  - Just to be used with thePrema as Master

\* According to guarantee conditions, see [www.theben.de/en/guarantee](http://www.theben.de/en/guarantee)

### Product selection

Installation type	Channel	Operating voltage	Colour	Type	Article number
Ceiling installation	Light   Presence	110–230 V AC	White	thePrema S360-101 E UP WH	2070605
			Grey	thePrema S360-101 E UP GR	2070606
	Light	110–230 V AC	White	thePrema S360-100 E UP WH	2070600
			Grey	thePrema S360-100 E UP GR	2070601
	Slave	110–230 V AC	White	thePrema S360 Slave E UP WH	2070630
			Grey	thePrema S360 Slave E UP GR	2070631

### Technical data

	thePrema S360-101 E UP	thePrema S360-100 E UP	thePrema S360 Slave E UP
Operating voltage	110–230 V AC		
Frequency	50–60 Hz		
Installation height	2–3,5 m		
Power consumption	0,1 W		
Setting range brightness	Approx. 5–3000 lx/on		–
Light switch-off delay	Pulse (0,5 s), 10 s–60 min		–
Type of contact light	Relay 230 V / 10 A µ-contact		–
Incandescent/halogen lamp load	2300 W		–
Compact and fluorescent lamps	1150 VA (cos φ = 0,5)		–
Inrush current	max. 800 A / 200 µs		–

# Presence and motion detectors

## Presence detectors, 230 V AC

	thePrema S360-101 E UP	thePrema S360-100 E UP	thePrema S360 Slave E UP
Compact and fluorescent lamps (max. number of electronic ballasts)	16 x 54/58 W, 24 x 35/36 W, 8 x 2 x 54/58 W, 12 x 2 x 35/36 W		-
LED lamp < 2 W	60 W		-
LED lamp 2-8 W	180 W		-
LED lamp > 8 W	200 W		-
Switch-on delay presence	0 s-10 min/Room surveillance		-
Presence switch-off delay	10 s-120 min		-
Type of contact presence	Relay potential-free, 220 V DC / 250 V AC		-
Switching capacity presence	50 W/50 VA (max. 2 A), min. 0,5 mV/10 mA		-
Size of concealed housing		Ø 55 mm (NIS, PMI)	
Ambient temperature		0 °C ... +50 °C	
Type of protection		IP 40 (when fitted)	

### Detection range (Square)

Mounting height (A)	Walking (T)	Sitting (S)
2 m	20 m²   4,5 m x 4,5 m ± 0,5 m	9 m²   3 m x 3 m
2,5 m	36 m²   6 m x 6 m ± 0,5 m	16 m²   4 m x 4 m
3 m	49 m²   7 m x 7 m ± 1 m	25 m²   5 m x 5 m
3,5 m	64 m²   8 m x 8 m ± 1 m	-

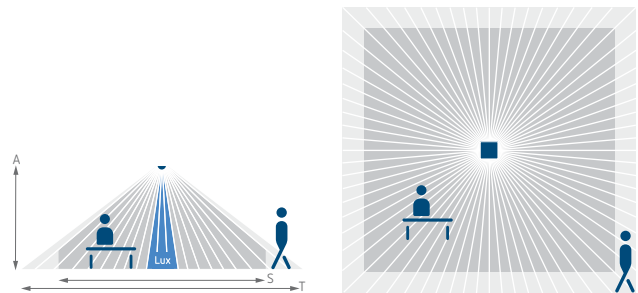

7

### Scale drawings

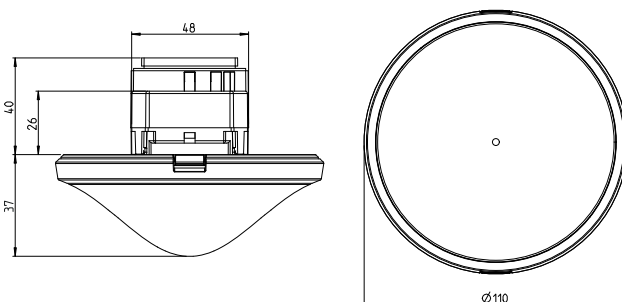

### Accessories



theSenda P  
↳ Art.No.: 9070910  
Details page 341

QuickSafe  
Details page 338

SendoPro 868-A  
Details page 339

theSenda S  
Details page 341

Surface frame 110A  
Details page 337

Ceiling installation box 73A  
Details page 337

### Connection diagrams

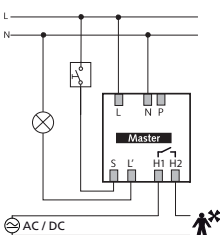

thePrema S360-101 E

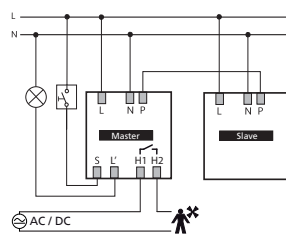

thePrema S360-101 E,  
thePrema S360 Slave E

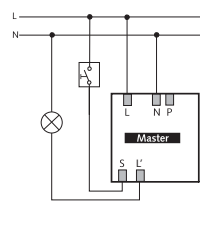

thePrema S360-100 E

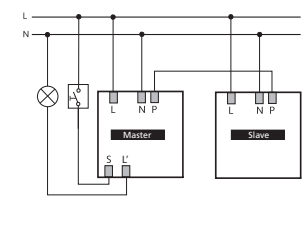

thePrema S360-100 E,  
thePrema S360 Slave E

# Presence and motion detectors

## Presence detectors, 230 V AC



### Description

#### thePrema P360-101 E

- Passive infrared presence detector for ceiling mounting
- Square detection area 360° (up to 100 m²) for reliable and easy planning
- Automatic presence- and brightness-dependent control for lighting and HVAC
- Mixed light measurement suitable for fluorescent lamps (FL/PL/ESL), halogen/ incandescent lamps and LEDs
- Light measurement can be switched to spot or wide measurement
- Channel A, light: relay, 230 V
- Choice of fully or semi-automatic (absence detection) operation
- Adjustable brightness switching value, teach-in function
- Self-learning time delay
- Reduction of switch-off delay time in the event of short presence (brief-presence)
- Connection option for sensors or switches for manual switching with automatic recognition of sensor/switch
- Pulse function for staircase light time switch
- Channel H, presence: relay, floating e.g. for HVAC control

- Switch-on delay and switch-off delay configurable
  - Room monitoring with selective movement detection
  - Exceptionally easy configuration of the energy-saving behaviour with the new «eco plus» function
  - Staircase time function
  - Operating mode of light and presence relay can be flexibly selected using the remote control SendaPro
  - User remote control theSenda S, management remote control SendaPro (optional)
  - Ready for immediate use due to factory preset
  - Test mode for checking function and detection area
  - Extension of detection area via Master/Slave or Master/Master switching, a maximum of 10 detectors can be switched in parallel with each other
  - Ceiling installation in flush-mounted socket
  - Ceiling installation also possible with surface-mounted frame
- thePrema P360 Slave E
- Slave version for thePrema
  - Just to be used with thePrema as Master

\* According to guarantee conditions, see [www.theben.de/en/guarantee](http://www.theben.de/en/guarantee)

### Product selection

Installation type	Channel	Operating voltage	Colour	Type	Article number
Ceiling installation	Light   Presence	110–230 V AC	White	thePrema P360-101 E UP WH	2070105
			Grey	thePrema P360-101 E UP GR	2070106
	Slave	110–230 V AC	White	thePrema P360 Slave E UP WH	2070130
			Grey	thePrema P360 Slave E UP GR	2070131

### Technical data

	thePrema P360-101 E UP	thePrema P360 Slave E UP
Operating voltage	110–230 V AC	
Frequency	50–60 Hz	
Installation height	2–10 m	
Power consumption	0,1 W	
Setting range brightness	Approx. 5–3000 lx/on	–
Light switch-off delay	Pulse (0,5 s), 10 s–60 min	–
Type of contact light	Relay 230 V/10 A μ-contact	–
Incandescent/halogen lamp load	2300 W	–
Compact and fluorescent lamps	1150 VA (cos φ = 0,5)	–
Inrush current	max. 800 A/200 μs	–
Compact and fluorescent lamps (max. number of electronic ballasts)	16 x 54/58 W, 24 x 35/36 W, 8 x 2 x 54/58 W, 12 x 2 x 35/36 W	–
LED lamp < 2 W	60 W	–
LED lamp 2–8 W	180 W	–

# Presence and motion detectors

## Presence detectors, 230 V AC

	thePrema P360-101 E UP	thePrema P360 Slave E UP
LED lamp > 8 W	200 W	-
Switch-on delay presence	0 s – 10 min/Room surveillance	-
Presence switch-off delay	10 s – 120 min	-
Type of contact presence	Relay potential-free, 220 V DC/250 V AC	-
Switching capacity presence	50 W/50 VA (max. 2 A), min. 0,5 mV/10 mA	-
Size of concealed housing	Ø 55 mm (NIS, PMI)	
Ambient temperature	0 °C ... +50 °C	
Type of protection	IP 40 (when fitted)	

### Detection range (Square)

Mounting height (A)	Walking (T)	Sitting (S)
2 m	36 m²   6 m x 6 m ± 0,5 m	20 m²   4,5 m x 4,5 m
2,5 m	64 m²   8 m x 8 m ± 0,5 m	36 m²   6 m x 6 m
3 m	81 m²   9 m x 9 m ± 1 m	49 m²   7 m x 7 m
3,5 m	100 m²   10 m x 10 m ± 1 m	64 m²   8 m x 8 m
6 m	144 m²   12 m x 12 m ± 1,5 m	-
10 m	400 m²   20 m x 20 m ± 2 m	-

With a mounting height of more than 3.5 m walking motions are necessary and the detection areas of several detectors should overlap in the marginal zone. All figures are up to values. The detection range decreases with increasing temperatures.

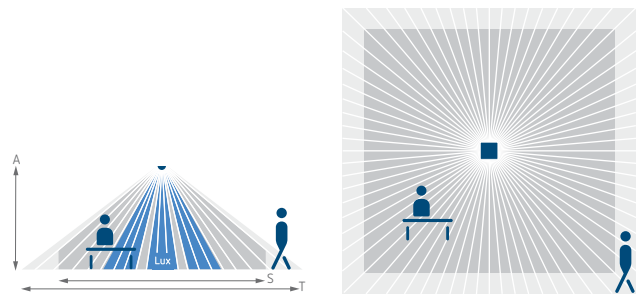

7

### Scale drawings

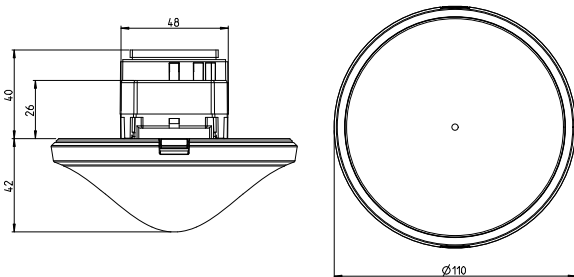

### Accessories



theSenda P  
↳ Art.No.: 9070910  
Details page 341

QuickSafe  
Details page 338

SendoPro 868-A  
Details page 339

theSenda S  
Details page 341

Surface frame 110A  
Details page 337

Ceiling installation box 73A  
Details page 337

### Connection diagrams

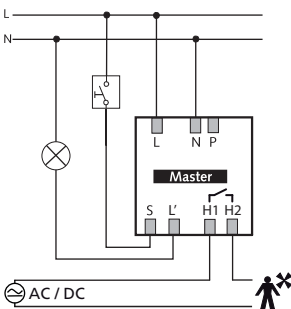

thePrema P360-101 E

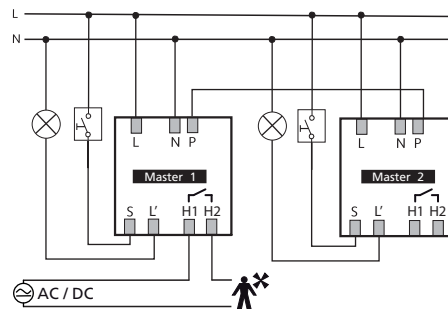

thePrema P360-101 E

# Presence and motion detectors

## Presence detectors, 230 V AC



### Description

- Presence detector (PIR)
- Square detection area
- Genuine daylight measurement
- Two light switch outputs (relay, 230 V)
- Automatic control of two lighting zones
- Lighting control with two light threshold values and self-learning switch-off delay
- Choice of fully or semi automatic operation
- Sensor or switch options for manual switching
- Inrush current limitation for EB
- Fully or semi-automatic: In „Fully automatic“ mode, the lighting switches on and off automatically according to presence and light. In „Semi-automatic“ mode, it must be switched on manually and it switches off automatically
- The presence detector has double „Genuine daylight measurement“ and is only suitable for switching fluorescent lamps (FL/PL)
- Device can be connected as master or slave
- Test operation mode checks the detection area and installation
- The parameters can either be set using the potentiometer or via the optional service remote control SendoPro 868-A
- A maximum of 10 detectors can be switched at the same time
- The square detection area allows accurate and simple planning

### Product selection

Installation type	Channel	Operating voltage	Colour	Type	Article number
Ceiling installation	2 x light	230 V AC	Pure white (similar to RAL 9010)	ECO-IR DUAL-C NT	2020401

7

### Technical data

	ECO-IR DUAL-C NT
Operating voltage	230 V AC
Frequency	50 Hz
Installation height	2–4 m
Power consumption	0,9 W
Setting range brightness	Approx. 10–1500 lx/on
Light switch-off delay	Pulse (0,5 s), 10 s–20 min
Type of contact light	Relay 230 V, switch-on current limit
Compact and fluorescent lamps	max. 1400 VA
Compact and fluorescent lamps (max. number of electronic ballasts)	16 x (1 x 54/58 W), 8 x (2 x 54/58 W), 24 x (1 x 35/36 W), 12 x (2 x 35/36 W), 24 x (smaller than 35/36 W)
Size of concealed housing	Ø 55 mm (NIS, PMI)
Ambient temperature	0 °C ... +50 °C
Type of protection	IP 40 (when fitted)

### Detection range (Square)

Mounting height (A)	Walking (T)	Sitting (S)
2 m	36 m²   6 m x 6 m ± 0,5 m	20 m²   4,5 m x 4,5 m
2,5 m	64 m²   8 m x 8 m ± 0,5 m	36 m²   6 m x 6 m
3 m	81 m²   9 m x 9 m ± 0,5 m	49 m²   7 m x 7 m
3,5 m	100 m²   10 m x 10 m ± 1 m	64 m²   8 m x 8 m
4 m	121 m²   11 m x 11 m ± 1 m	–

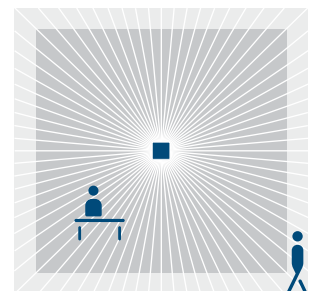
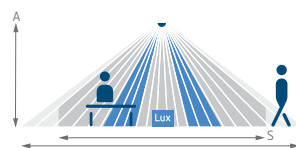

Accessories



SendoPro 868-A  
↳ Art.No.: 9070675  
Details page 339



QuickSafe  
↳ Art.Nr.: 9070531  
Details page 338

Scale drawings

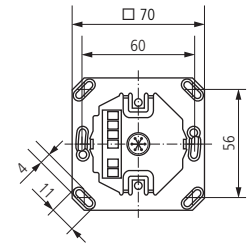
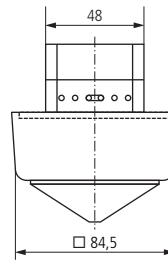
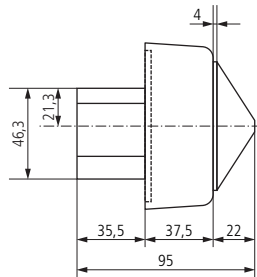
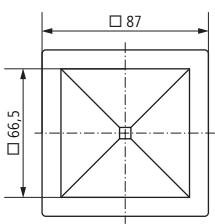

7

Connection diagrams

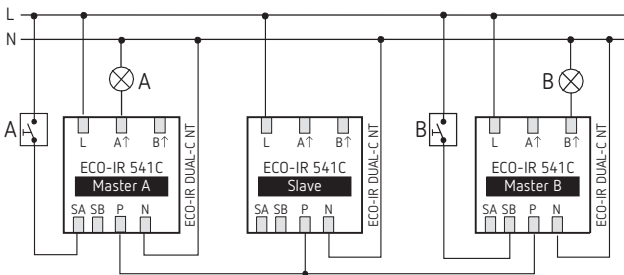
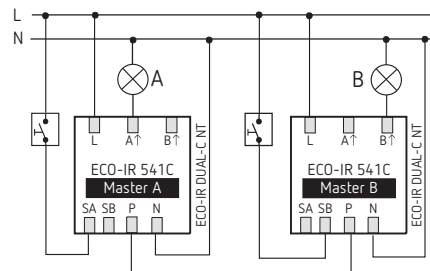
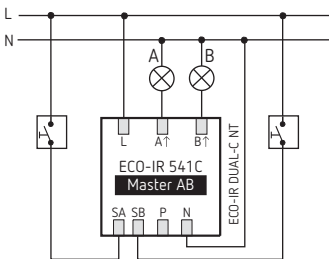

# Presence and motion detectors

## Presence detectors, 230 V AC



### Description

- Presence detector (PIR)
- Automatic control of lighting depending on presence and brightness
- Flush design using concave mirror technology
- Cover frame in white included in delivery, cover frames in black or silver available as optional accessories
- Square detection area for accurate and easy planning
- Light switch output (relay, 230 V)
- Mixed light measurement, suitable for fluorescent lamps (FL/PL/ESL), halogen/ incandescent lamps and LEDs
- Brightness threshold and self-learning switch-off delay adjustable
- Push button or switch connection for manual control
- Pulse function for staircase time switch
- Choice of fully or semi automatic operation: In „Semi-automatic“ (absence detection) mode the light must be switched on manually and switches off automatically
- Presence switch output (relay, potential-free) for example for HVAC control
- HVAC control with adjustable switch-on and switch-off delay
- Function „monitoring“ with reduced sensitivity only to detect walking persons
- Ready for use by 6 predefined settings, details can be set using the optional service remote control SentoPro
- Parameters can be selected for subsequent changes
- Adjustable sensitivity
- Optional user remote control
- Test operation to check detection area, installation, brightness settings
- Master/slave or master/master parallel switching: Up to ten detectors can be connected with each other to extend the detection area
- Individual covers available upon request

#### PlanoCentro 101-EWH

- For ceiling installation (false ceilings)
- With installation for false ceilings and cover

#### PlanoCentro 000-EWH

- Slave-Version for PlanoCentro 101-EWH
- Just to be used with PlanoCentro 101-EWH as Master

#### PlanoCentro 101-UWH

- For flush-mounting (concrete ceiling)
- With metal installation frame for screwed fixing in wooden ceilings or in flush-mounted sockets, incl. cover

#### PlanoCentro 000-UWH

- Slave-Version for PlanoCentro 101-UWH
- Just to be used with PlanoCentro 101-UWH as Master

7

### Product selection

Installation type	Channel	Operating voltage	Colour	Type	Article number
Ceiling mounting with mounting frame	Light   Presence	230 V AC	Pure white (similar to RAL 9010)	PlanoCentro 101-EWH	2030102
	Slave	230 V AC	Pure white (similar to RAL 9010)	PlanoCentro 000-EWH	2040102
Ceiling installation (flush-mounting concrete)	Light   Presence	230 V AC	Pure white (similar to RAL 9010)	PlanoCentro 101-UWH	2030202
	Slave	230 V AC	Pure white (similar to RAL 9010)	PlanoCentro 000-UWH	2040202

### Technical data

	PlanoCentro 101	PlanoCentro 000
Operating voltage	230 V AC	
Frequency	50 Hz	
Installation height	2 – 3,5 m	
Power consumption	ca. 0,8 W	0,3 W
Setting range brightness	Approx. 5 – 2000 lx/on	
Light switch-off delay	Pulse (0,5 s), 10 s – 60 min	
Type of contact light	Relay 230 V/10 A	
Incandescent/halogen lamp load	2300 W	
Compact and fluorescent lamps	1150 VA (cos φ = 0,5)	

# Presence and motion detectors

## Presence detectors, 230 V AC

	PlanoCentro 101	PlanoCentro 000
Compact and fluorescent lamps (max. number of electronic ballasts)	20 x 54/58 W, 25 x 35/36 W, 10 x 2 x 54/58 W, 15 x 2 x 35/36 W	-
LED lamp < 2 W	60 W	-
LED lamp 2-8 W	180 W	-
LED lamp > 8 W	200 W	-
Switch-on delay presence	0 s-10 min	-
Presence switch-off delay	10 s-120 min	-
Type of contact presence	Relay potential-free, 220 V DC/250 V AC	-
Switching capacity presence	60 W (220 V DC), 62,5 VA (250 V AC), min. 0,5 mV/10 mA	-
Ambient temperature	0 °C ... +50 °C	
Type of protection	IP 40 (when fitted)	

### Detection range (Square)

Mounting height (A)	Walking (T)	Sitting (S)
2 m	36 m <sup>2</sup>   6 m x 6 m ± 0,5 m	20 m <sup>2</sup>   4,5 m x 4,5 m
2,5 m	64 m <sup>2</sup>   8 m x 8 m ± 0,5 m	36 m <sup>2</sup>   6 m x 6 m
3 m	81 m <sup>2</sup>   9 m x 9 m ± 1 m	49 m <sup>2</sup>   7 m x 7 m
3,5 m	100 m <sup>2</sup>   10 m x 10 m ± 1 m	64 m <sup>2</sup>   8 m x 8 m

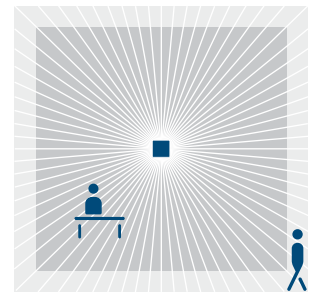
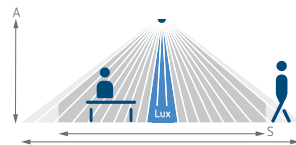

7

### Accessories



**PlanoSets**  
for PlanoCentro-E  
↳ Art.No.: 9070736  
Details page 338



**theSenda S**  
↳ Art.No.: 9070911  
Details page 341



**SendoPro 868-A**  
↳ Art.No.: 9070675  
Details page 339

**theSenda P**  
Details page 341

**Junction casing,**  
115 x 115 x 100 mm  
for PlanoCentro U  
Details page 338

**PlanoBox**  
for PlanoCentro U  
Details page 338

**QuickSafe**  
Details page 338

**PlanoCover 112 x 112**  
for PlanoCentro E  
Details page 338

**PlanoCover 123 x 123**  
for PlanoCentro U  
Details page 338

# Presence and motion detectors

## Presence detectors, 230 V AC



### Description

- Presence detector (PIR)
  - Automatic control of lighting depending on presence and brightness
  - Flush design using concave mirror technology
  - Cover frame in white included in delivery, cover frames in black or silver available as optional accessories
  - Square detection area for accurate and easy planning
  - Mixed light measurement, suitable for fluorescent lamps (FL/PL/ESL), halogen/ incandescent lamps and LEDs
  - Brightness threshold and self-learning switch-off delay adjustable
  - Push button or switch connection for manual control
  - Pulse function for staircase time switch
  - Choice of fully or semi automatic operation: In „Semi-automatic“ (absence detection) mode the light must be switched on manually and switches off automatically
  - Ready for use by 6 predefined settings, details can be set using the optional service remote control SendoPro
  - Parameters can be selected for subsequent changes
  - Adjustable sensitivity
  - Optional user remote control
  - Test operation to check detection area, installation, brightness settings
  - Master/slave or master/master parallel switching: Up to ten detectors can be connected with each other to extend the detection area
  - Individual covers available upon request
- PlanoCentro 201**
- Channels A, B light: relay, 230V
  - Zero cross switching
  - Channel H, presence: relay, floating
  - Switch-on delay and switch-off delay
  - Room surveillance
  - Detection area can be extended by using slave-version PlanoCentro 000
  - For ceiling installation (false ceilings), with installation for false ceilings and cover (PlanoCentro 201-E)
  - For flush-mounting (concrete ceiling), with metal installation frame for screwed fixing in wooden ceilings or in flush-mounted sockets, incl. cover (PlanoCentro 201)
- PlanoCentro 300**
- 3 light channels
  - Ideal for classrooms with two lighting groups switched according to daylight each with their own light measurement as well as presence-dependent controlled black-board lighting
  - A, B, C channels light: relay, 230V
  - Zero cross switching
  - Detection area can be extended by using slave-version PlanoCentro 000
  - For ceiling installation (false ceilings), with installation for false ceilings and cover (PlanoCentro 300-E)
  - For flush-mounting (concrete ceiling), with metal installation frame for screwed fixing in wooden ceilings or in flush-mounted sockets, incl. cover (PlanoCentro 300-U)

7

### Product selection

Installation type	Channel	Operating voltage	Colour	Type	Article number
Ceiling mounting with mounting frame	3 x light	230 V AC	Pure white (similar to RAL 9010)	PlanoCentro 300-EWH	2030302
Ceiling installation (flush-mounting concrete)	3 x light	230 V AC	Pure white (similar to RAL 9010)	PlanoCentro 300-UWH	2030402
Ceiling mounting with mounting frame	2 x Light   1 x Presence	230 V AC	Pure white (similar to RAL 9010)	PlanoCentro 201-EWH	2030502
Ceiling installation (flush-mounting concrete)	2 x Light   1 x Presence	230 V AC	Pure white (similar to RAL 9010)	PlanoCentro 201-UWH	2030602

### Technical data

	PlanoCentro 300	PlanoCentro 201
Operating voltage	230 V AC ± 10 %	
Frequency	50 Hz	
Installation height	2 – 3,5 m	
Power consumption	1 W	
Setting range brightness	Approx. 10 – 2000 lx/on	

# Presence and motion detectors

## Presence detectors, 230 V AC

	PlanoCentro 300	PlanoCentro 201
Light switch-off delay	10 s–60 min	
Type of contact light	Relay 230 V/10 A	
Incandescent/halogen lamp load	2300 W, (total of all contacts)	
Compact and fluorescent lamps	1150 VA (cos φ = 0,5)	
Compact and fluorescent lamps (max. number of electronic ballasts)	20 x 54/58 W, 25 x 35/36 W, 10 x 2 x 54/58 W, 15 x 2 x 35/36 W	
LED lamp < 2 W	60 W	
LED lamp 2–8 W	180 W	
LED lamp > 8 W	200 W	
Switch-on delay presence	–	0 s–10 min/Room surveillance
Presence switch-off delay	–	10 s–120 min
Type of contact presence	–	Relay potential-free, 220 V DC/250 V AC
Switching capacity presence	–	60 W (220 V DC), 62,5 VA (250 V AC), minimal 0,5 mV/10mA
Ambient temperature	0 °C ... +50 °C	
Type of protection	IP 40 (when fitted)	

### Detection range (Square)

Mounting height (A)	Walking (T)	Sitting (S)
2 m	36 m <sup>2</sup>   6 m x 6 m ± 0,5 m	20 m <sup>2</sup>   4,5 m x 4,5 m
2,5 m	64 m <sup>2</sup>   8 m x 8 m ± 0,5 m	36 m <sup>2</sup>   6 m x 6 m
3 m	81 m <sup>2</sup>   9 m x 9 m ± 1 m	49 m <sup>2</sup>   7 m x 7 m
3,5 m	100 m <sup>2</sup>   10 m x 10 m ± 1 m	64 m <sup>2</sup>   8 m x 8 m

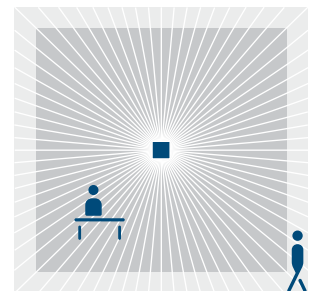
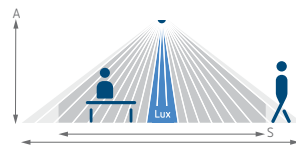

7

### Accessories



**PlanoSets**  
for PlanoCentro-E  
↳ Art.No.: 9070736  
Details page 338



**theSenda S**  
↳ Art.No.: 9070911  
Details page 341



**SendoPro 868-A**  
↳ Art.No.: 9070675  
Details page 339

**theSenda P**  
Details page 341  
**Junction casing,**  
115 x 115 x 100 mm  
for PlanoCentro U  
Details page 338

**PlanoBox**  
for PlanoCentro U  
Details page 338  
**QuickSafe**  
Details page 338

**PlanoCover 112 x 112**  
for PlanoCentro E  
Details page 338

**PlanoCover 123 x 123**  
for PlanoCentro U  
Details page 338

# Presence and motion detectors

## Presence detectors, 230 V AC

### Scale drawings

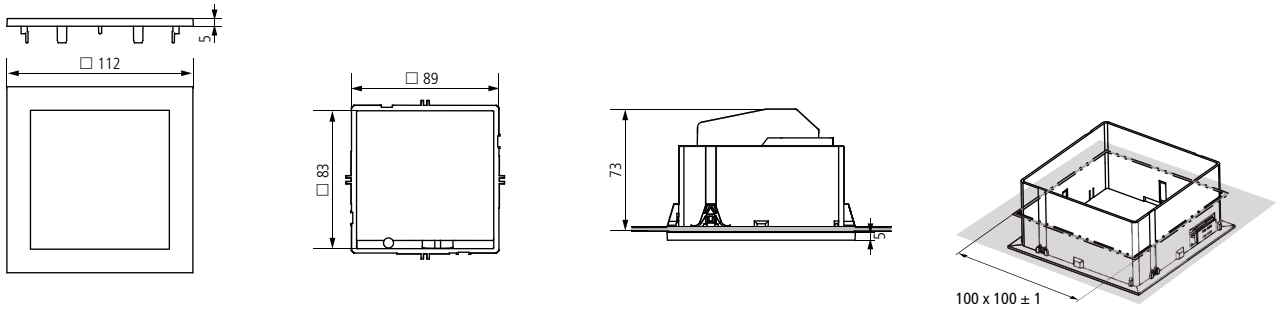

PlanoCentro E

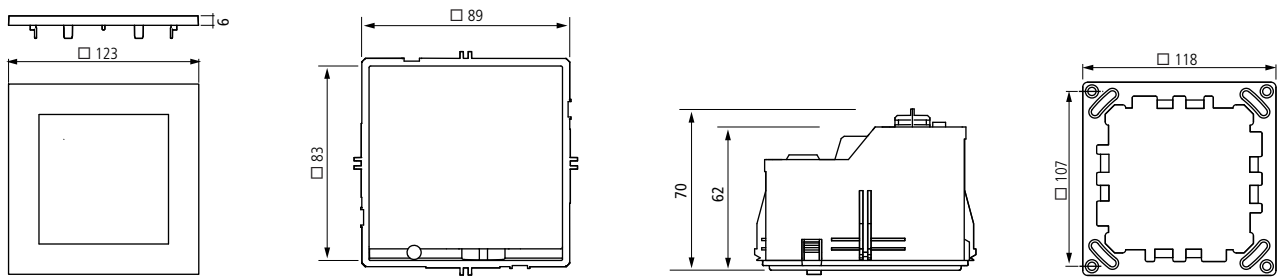

PlanoCentro U

7

### Connection diagrams

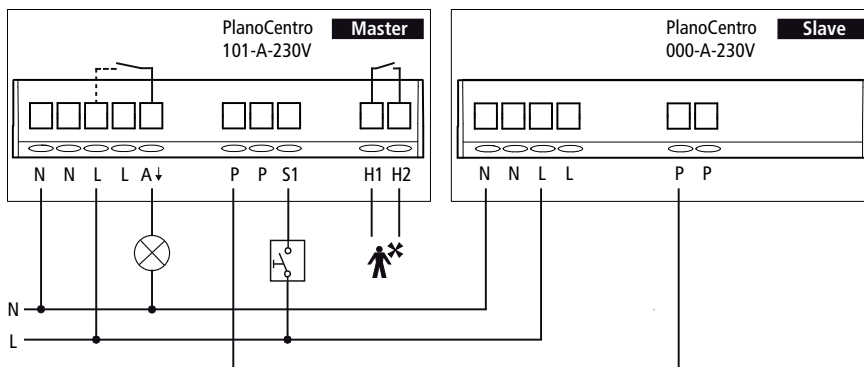

PlanoCentro 101

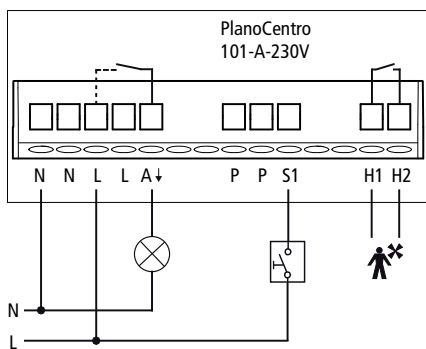

PlanoCentro 101

Connection diagrams

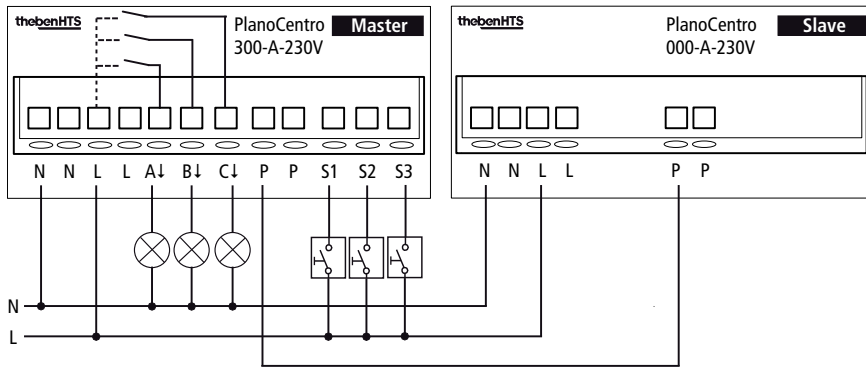

PlanoCentro 300

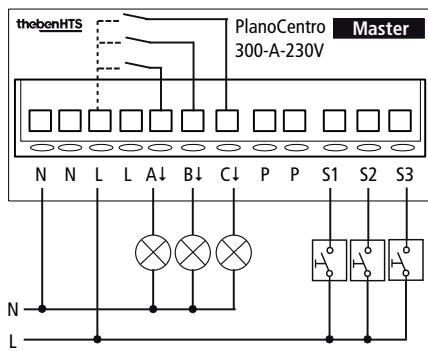

PlanoCentro 300

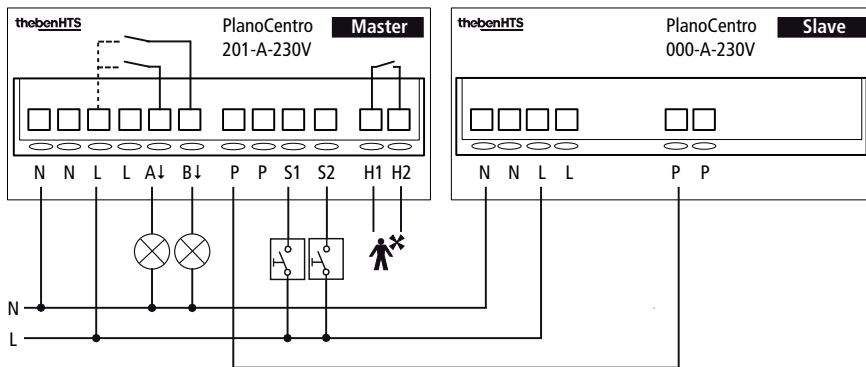

PlanoCentro 201

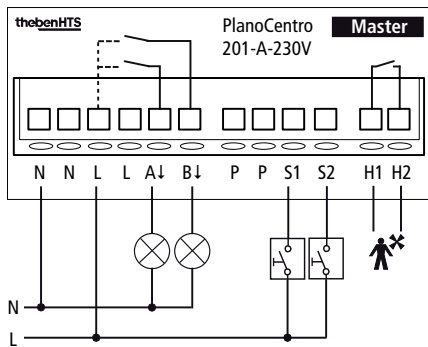

PlanoCentro 201

# Presence and motion detectors

## Presence detectors, 230 V AC



PresenceLight 180

### Description

- Presence detector (PIR)
- Automatic control of lighting depending on presence and brightness
- Cover frame in white included in delivery, cover frames in black or silver available as optional accessories
- IP 54 for versatile use
- Light switch output (relay, 230 V)
- Mixed light measurement, suitable for fluorescent lamps (FL/PL/ESL), halogen/ incandescent lamps and LEDs
- Brightness threshold and self-learning switch-off delay adjustable
- Pulse function for staircase time switch
- Parameters can be set using the potentiometers or via the optional service remote controls
- Optional user remote control
- Ready for use by ex-factory set items
- Test operation to check detection area and installation
- Wall mounting in flush-mounted box
- Possibility of surface mounting by using a surface frame

### Product selection

Installation type	Channel	Operating voltage	Colour	Type	Article number
Wall installation	Light	230 V AC	Pure white (similar to RAL 9010)	PresenceLight 180	2000050

### Technical data

	PresenceLight 180
Operating voltage	230 V AC
Frequency	50 Hz
Installation height	1,7–2,2 m
Power consumption	0,9 W
Setting range brightness	Approx. 10–1500 lx/on
Light switch-off delay	Pulse (0,5 s), 10 s–20 min
Type of contact light	Relay 230 V
Resistive load	1400 W
Incandescent/halogen lamp load	1200 W
Compact and fluorescent lamps	960 VA (cos φ = 0,8), 580 VA (cos φ = 0,5)
Compact and fluorescent lamps (max. number of electronic ballasts)	10 x (1 x 54/58 W), 5 x (2 x 54/58 W), 16 x (1 x 35/36 W), 8 x (2 x 35/36 W), 16 x (smaller than 35/36 W)
LED lamp < 2 W	25 W
LED lamp 2–8 W	70 W
LED lamp > 8 W	80 W
Size of concealed housing	Ø 55 mm (NIS, PMI)
Ambient temperature	–20 °C ... +50 °C
Type of protection	IP 54

### Detection range (Semicircular)

Mounting height (A)	Walking (T)	Sitting (S)
2,2 m	100 m <sup>2</sup>   8 m	25 m <sup>2</sup>   7 m x 3,5 m

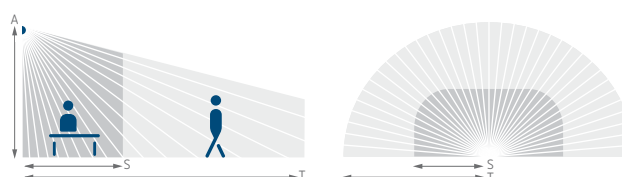

Accessories



Surface frame PresenceLight  
↳ Art.No.: 9070513  
Details page 336



SendoPro 868-A  
↳ Art.No.: 9070675  
Details page 339

QuickSafe

Details page 338

Cover frame PresenceLight  
180 SR

Details page 337

Cover frame PresenceLight  
180 BK

Details page 337

Surface frame PresenceLight BK  
Details page 336

Surface frame PresenceLight SR  
Details page 336

Ceiling installation box 73A  
Details page 337

Scale drawings

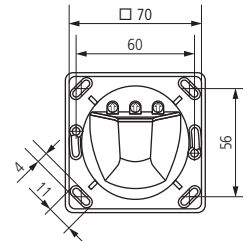
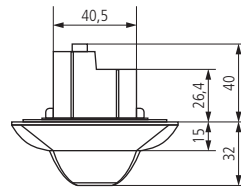
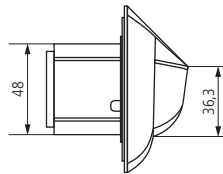
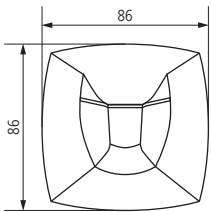

7

Connection diagrams

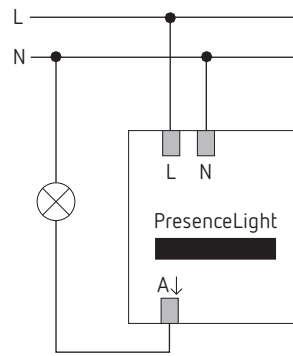
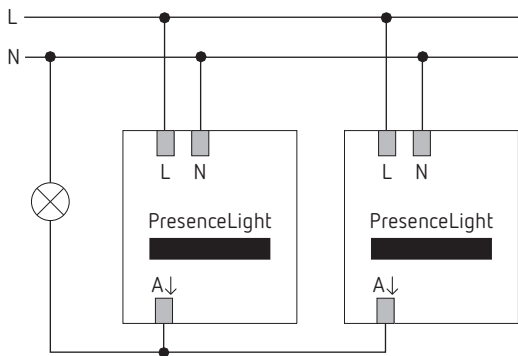

# Presence and motion detectors

## Presence detectors, 24 V AC/DC



### Description

- Presence detector (PIR)
- Automatic control of lighting depending on presence and brightness
- Square detection area allows accurate and simple planning
- Light switch output (relay, potential-free)
- Mixed light measurement, suitable for fluorescent lamps (FL/PL/ESL), halogen/ incandescent lamps and LEDs
- Brightness threshold and self-learning switch-off delay adjustable
- Pulse function for staircase time switch
- Presence switch output (relay, potential-free) for example for HVAC control
- HVAC control with adjustable switch-on and switch-off delay
- Function „monitoring“ with reduced sensitivity only to detect walking persons
- Parameters can be set using the potentiometers or via the optional service remote controls
- Optional user remote control
- Ready for use by ex-factory set items
- Test operation to check detection area and installation
- Ceiling mounting in flush-mounted box
- Possibility of surface mounting by using a surface frame

### Product selection

Installation type	Channel	Operating voltage	Colour	Type	Article number
Ceiling installation	Light   Presence	24 V AC/DC	Pure white (similar to RAL 9010)	compact office 24V	2014000

### Technical data

	compact office 24V
Operating voltage	24 V AC/DC
Installation height	2–3,5 m
Power consumption	0,4 W
Setting range brightness	Approx. 10–1500 lx/on
Light switch-off delay	Pulse (0,5 s), 10 s–20 min
Type of contact light	Relay potential-free
Switching contact light A	50 W (24 V AC/DC), 460 VA (230 V AC), $\mu$ , min. 1 V/1 mA
Switch-on delay presence	0 s–10 min
Presence switch-off delay	10 s–120 min
Type of contact presence	Relay potential-free, 220 V DC/250 V AC
Switching contact presence B	50 W (24 V AC/DC), 460 VA (230 V AC), $\mu$ , min. 1 V/1 mA
Size of concealed housing	$\emptyset$ 55 mm (NIS, PMI)
Ambient temperature	0 °C ... +50 °C
Type of protection	IP 40 (when fitted)

7

Detection range (Square)

Mounting height (A)	Walking (T)	Sitting (S)
2 m	20 m <sup>2</sup>   4,5 m x 4,5 m ± 0,5 m	9 m <sup>2</sup>   3 m x 3 m
2,5 m	36 m <sup>2</sup>   6 m x 6 m ± 0,5 m	16 m <sup>2</sup>   4 m x 4 m
3 m	49 m <sup>2</sup>   7 m x 7 m ± 1 m	20 m <sup>2</sup>   4,5 m x 4,5 m
3,5 m	64 m <sup>2</sup>   8 m x 8 m ± 1 m	-

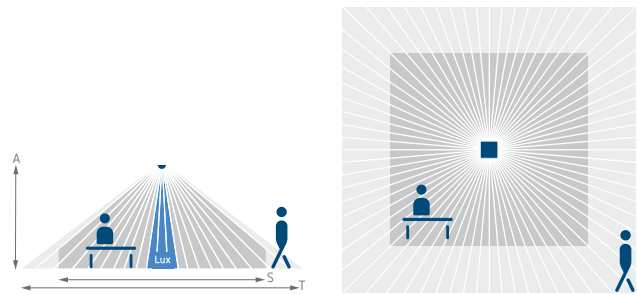

Accessories



Surface frame compact  
↳ Art.No.: 9070514  
Details page 337



SendoPro 868-A  
↳ Art.No.: 9070675  
Details page 339

QuickSafe  
Details page 338

Ceiling installation box 73A  
Details page 337

Scale drawings

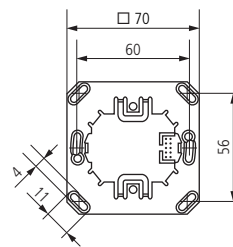
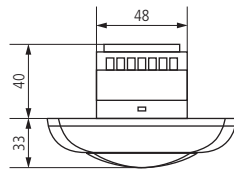
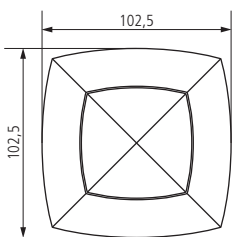

Connection diagrams

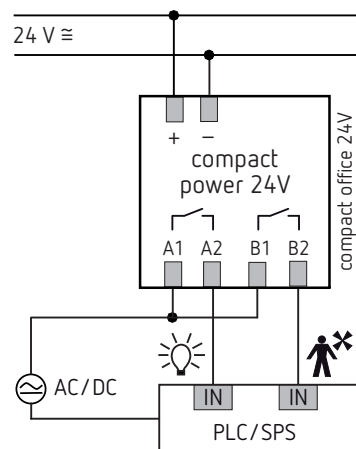
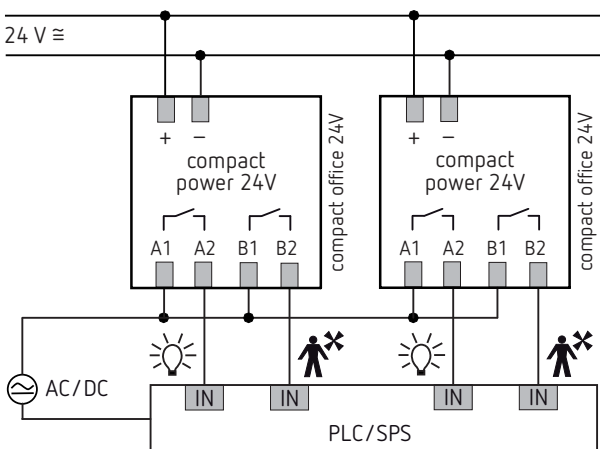

# Presence and motion detectors

## Presence detectors, 24 V AC/DC



### Description

- Presence detector (PIR)
- Automatic control of lighting depending on presence and brightness and analogue value output of measured brightness
- Square detection area allows accurate and simple planning
- Light switch output (relay, potential-free)
- Mixed light measurement, suitable for fluorescent lamps (FL/PL/ESL), halogen/ incandescent lamps and LEDs
- Brightness threshold and self-learning switch-off delay adjustable
- Analogue output 0–10 V for brightness
- Linear or logarithmic output of brightness
- Can be used as light sensor for PLC controls
- The analogue output exports the brightness measured by the internal sensor as an analogue signal. The output can be linear or logarithmic to the measured brightness. The output functions independently from the presence detector
- Pulse function for staircase time switch
- Parameters can be set using the potentiometers or via the optional service remote controls
- Optional user remote control
- Ready for use by ex-factory set items
- Test operation to check detection area and installation
- Ceiling mounting in flush-mounted box
- Possibility of surface mounting by using a surface frame

### Product selection

Installation type	Channel	Operating voltage	Colour	Type	Article number
Ceiling installation	Light   0–10 V	24 V AC/DC	Pure white (similar to RAL 9010)	compact office 24V Lux	2014001

### Technical data

	compact office 24V Lux
Operating voltage	24 V AC/DC
Installation height	2–3,5 m
Power consumption	0,5 W
Setting range brightness	Approx. 10–1500 lx/on
Light switch-off delay	Pulse (0,5 s), 10 s–20 min
Type of contact light	Relay potential-free
Switching contact light A	50 W (24 V AC/DC), 460 VA (230 V AC), $\mu$ , min. 1 V/1 mA
Size of concealed housing	Ø 55 mm (NIS, PMI)
Ambient temperature	0 °C ... +50 °C
Type of protection	IP 40 (when fitted)

7

Detection range (Square)

Mounting height (A)	Walking (T)	Sitting (S)
2 m	20 m <sup>2</sup>   4,5 m x 4,5 m ± 0,5 m	9 m <sup>2</sup>   3 m x 3 m
2,5 m	36 m <sup>2</sup>   6 m x 6 m ± 0,5 m	16 m <sup>2</sup>   4 m x 4 m
3 m	49 m <sup>2</sup>   7 m x 7 m ± 1 m	20 m <sup>2</sup>   4,5 m x 4,5 m
3,5 m	64 m <sup>2</sup>   8 m x 8 m ± 1 m	-

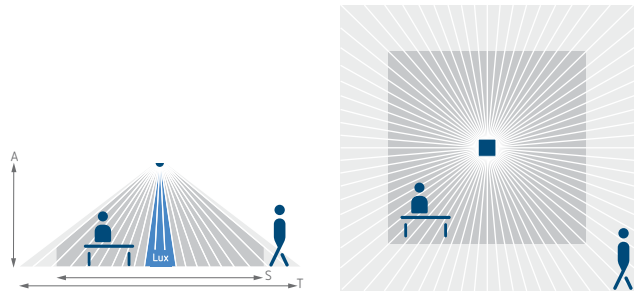

Accessories



Surface frame compact  
↳ Art.No.: 9070514  
Details page 337



SendoPro 868-A  
↳ Art.No.: 9070675  
Details page 339

QuickSafe

Details page 338

Ceiling installation box 73A

Details page 337

Scale drawings

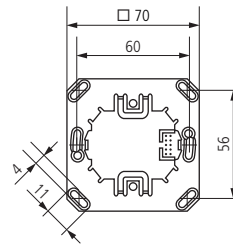
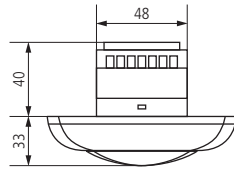
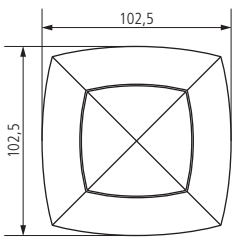

Connection diagrams

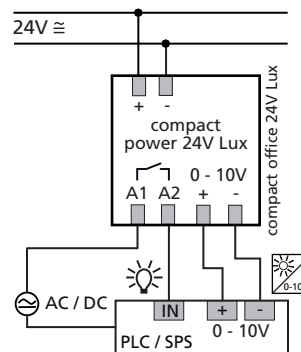
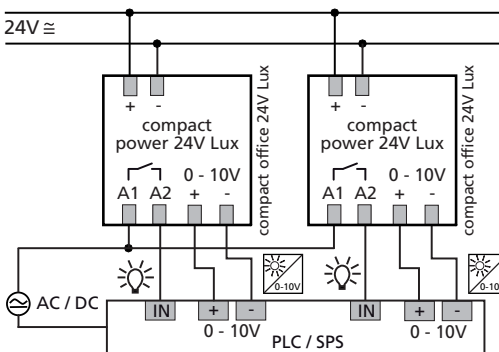

# Presence and motion detectors

## Presence detectors, 24 V AC/DC



### Description

- Presence detector (PIR)
- Automatic control of lighting depending on presence and brightness
- Rectangular detection area for corridors allows accurate and simple planning
- Light switch output (relay, potential-free)
- Mixed light measurement, suitable for fluorescent lamps (FL/PL/ESL), halogen/ incandescent lamps and LEDs
- Brightness threshold and self-learning switch-off delay adjustable
- Pulse function for staircase time switch
- Presence switch output (relay, potential-free) for example for HVAC control
- HVAC control with adjustable switch-on and switch-off delay
- Function „monitoring“ with reduced sensitivity only to detect walking persons
- Parameters can be set using the potentiometers or via the optional service remote controls
- Optional user remote control
- Ready for use by ex-factory set items
- Test operation to check detection area and installation
- Ceiling mounting in flush-mounted box
- Possibility of surface mounting by using a surface frame

### Product selection

Installation type	Channel	Operating voltage	Colour	Type	Article number
Ceiling installation	Light   Presence	24 V AC/DC	Pure white (similar to RAL 9010)	compact passage 24V	2014090

### Technical data

	compact passage 24V
Operating voltage	24 V AC/DC
Installation height	2 – 6 m
Power consumption	0,4 W
Setting range brightness	Approx. 10 – 1500 lx/on
Light switch-off delay	Pulse (0,5 s), 10 s – 20 min
Type of contact light	Relay potential-free
Switching contact light A	50 W (24 V AC/DC), 460 VA (230 V AC), $\mu$ , min. 1 V/1 mA
Switch-on delay presence	0 s – 10 min
Presence switch-off delay	10 s – 120 min
Type of contact presence	Relay potential-free, 220 V DC/250 V AC
Switching contact presence B	50 W (24 V AC/DC), 460 VA (230 V AC), $\mu$ , min. 1 V/1 mA
Size of concealed housing	$\emptyset$ 55 mm (NIS, PMI)
Ambient temperature	0 °C ... +50 °C
Type of protection	IP 40 (when fitted)

7

Detection range (Rectangular)

Mounting height (A)	Head on to (r)	Diagonally (t)
2 m	56 m <sup>2</sup>   16 m x 3,5 m ± 1,5 m	56 m <sup>2</sup>   16 m x 3,5 m ± 1,5 m
2,5 m	72 m <sup>2</sup>   18 m x 4 m ± 1,5 m	88 m <sup>2</sup>   22 m x 4 m ± 1,5 m
3 m	90 m <sup>2</sup>   20 m x 4,5 m ± 1,5 m	135 m <sup>2</sup>   30 m x 4,5 m ± 1,5 m
3,5 m	100 m <sup>2</sup>   20 m x 5 m ± 1,5 m	150 m <sup>2</sup>   30 m x 5 m ± 1,5 m
4 m	100 m <sup>2</sup>   20 m x 5 m ± 2 m	150 m <sup>2</sup>   30 m x 5 m ± 2 m
4,5 m	100 m <sup>2</sup>   20 m x 5 m ± 2 m	150 m <sup>2</sup>   30 m x 5 m ± 2 m
5 m	100 m <sup>2</sup>   20 m x 5 m ± 2,5 m	150 m <sup>2</sup>   30 m x 5 m ± 2,5 m
6 m	100 m <sup>2</sup>   20 m x 5 m ± 2,5 m	150 m <sup>2</sup>   30 m x 5 m ± 2,5 m

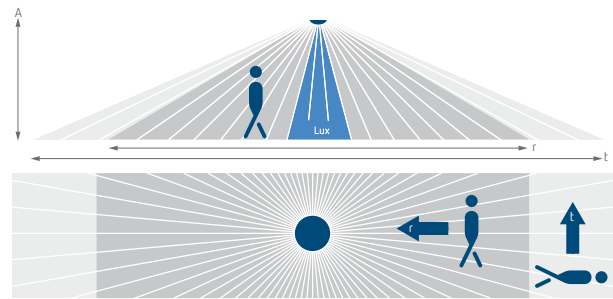

Accessories



Surface frame compact  
↳ Art.No.: 9070514  
Details page 337



SendoPro 868-A  
↳ Art.No.: 9070675  
Details page 339

QuickSafe

Details page 338

Ceiling installation box 73A

Details page 337

Scale drawings

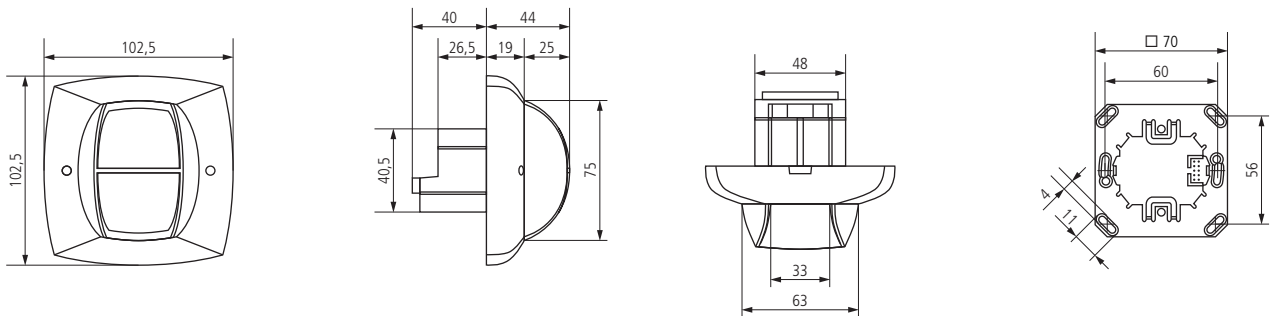

Connection diagrams

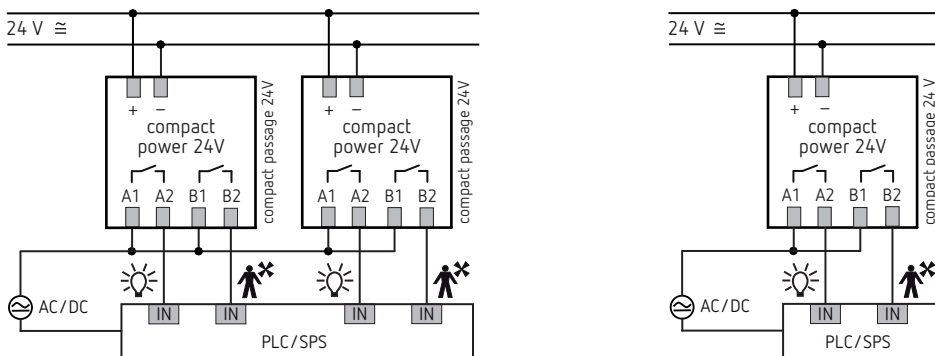

# Presence and motion detectors

## Presence detectors, DALI



### Description

- Passive infrared presence detector for ceiling mounting
- Square 360° detection range for an accurate and simple planning
- DALI interface in accordance with EN 62386 for max. 25 DALI electronic ballasts
- Automatic allocation of DALI participants (DALI Broadcast)
- Automatic lighting regulation with constant light control
- Mixed light measurement suitable for switching fluorescent lamps (FL/PL), halogen and incandescent lamps as well as LEDs
- Facility to connect a push button for manual dimming and switching (single-button control)
- Fully or semi-automatic operation switch-selectable
- Brightness switching level, self-learning switch-off delay time, stand-by time and stand-by brightness can be adjusted
- Scene component with two built-in scenes
- Ready for immediate use due to factory preset
- Test mode for checking function and detection area
- Extension of detection area via Master/Slave or Master/Master switching, a maximum of 10 detectors can be switched at the same time
- Ceiling installation in flush-mounted socket
- Ceiling installation possible with surface-mounted frame
- User remote control theSenda S (option)
- Service remote control SendoPro (option)

7

\* According to guarantee conditions, see [www.theben.de/en/guarantee](http://www.theben.de/en/guarantee)

### Product selection

Installation type	Channel	Operating voltage	Colour	Type	Article number
Ceiling installation	DALI	230 V AC	White	thePrema S360 DALI UP WH	2070525
			Grey	thePrema S360 DALI UP GR	2070526

### Technical data

	thePrema S360 DALI UP WH	thePrema S360 DALI UP GR
Operating voltage	230 V AC	
Frequency	50 Hz	
Installation height	2–3,5 m	
Minimum height	> 1,7 m	
Power consumption	0,5 W	
Setting range brightness	5–3000 lx	
Stand-by time light	0 s–60 min/on	
Stand-by brightness	1–25 %	
Control output	50 mA	
Size of concealed housing	Ø 55 mm (NIS, PMI)	
Ambient temperature	0 °C ... +50 °C	
Type of protection	IP 40 (when fitted)	

Detection range (Square)

Mounting height (A)	Walking (T)	Sitting (S)
2 m	20 m <sup>2</sup>   4,5 m x 4,5 m ± 0,5 m	9 m <sup>2</sup>   3 m x 3 m
2,5 m	36 m <sup>2</sup>   6 m x 6 m ± 0,5 m	16 m <sup>2</sup>   4 m x 4 m
3 m	49 m <sup>2</sup>   7 m x 7 m ± 1 m	25 m <sup>2</sup>   5 m x 5 m
3,5 m	64 m <sup>2</sup>   8 m x 8 m ± 1 m	-

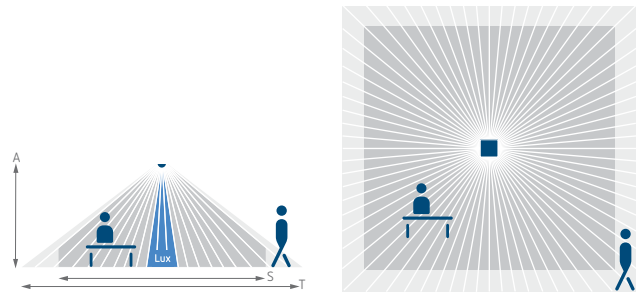

Accessories



Surface frame 110A WH  
↳ Art.No.: 9070912  
Details page 337



theSenda P  
↳ Art.No.: 9070910  
Details page 341



theSenda S  
↳ Art.No.: 9070911  
Details page 341

Surface frame 110A GR  
Details page 337

SendoPro 868-A  
Details page 339

Ceiling installation box 73A  
Details page 337

QuickSafe  
Details page 338

Scale drawings

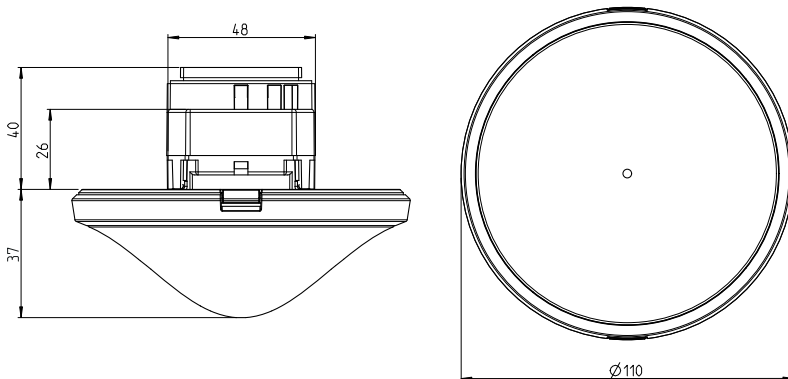

Connection diagrams

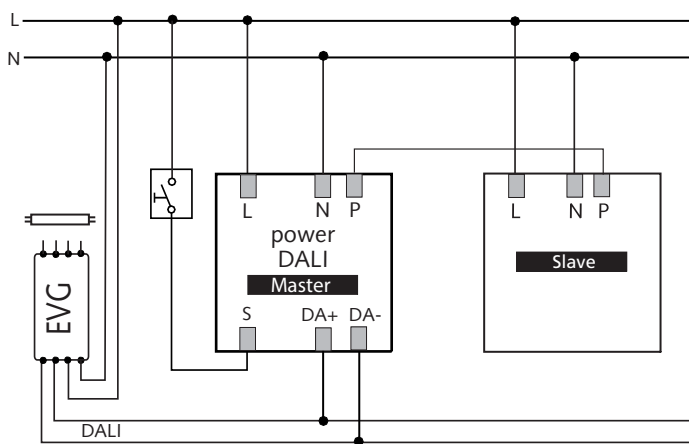

thePrema S360 DALI

thePrema S360 Slave E

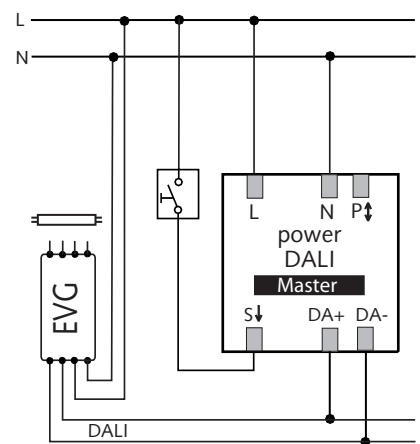

thePrema S360 DALI

# Presence and motion detectors

## Presence detectors, DALI



### Description

theRonda P360-110 DALI UP,  
theRonda S360-110 DALI UP

- Passive infrared presence detector for ceiling mounting
- Round detection area 360°
- 1 light channel DALI broadcast
- 1 push-button input
- Using of conventional push-buttons for maximum design freedom
- Switch or constant light control mode with stand-by function
- Dimmable lighting in switch mode with stand-by function
- Choice of fully or semi-automatic operation
- Adjustable brightness switching value
- Teach-in function via remote control or push-button
- Setting of room correction factor (Automatic adjustment of brightness measurement)
- Light time delay can be set
- Calibrated 1 channel light measurement
- Brief-presence
- Self-learning time delay
- Extremely easy setting of energy saving characteristics with the new „eco plus“ function

- Selectable control speed
- Manual override via remote control or push-button
- Behavior after push button operation selectable (school / office)
- Test mode light
- Test-Mode presence
- Remote-controllable
- Scenes
- Sensitivity adjustable
- Detection area can be limited using cover clip
- Extension of detection area via Master/Slave or Master/Master switching
- Optimized handling by installer during assembly, wiring, commissioning

theRonda P360-330 DALI UP

As theRonda S360-110 & P360-110, but:

- Flexible assignment of up to 3 light groups towards one DALI line
- Easy, intuitive configuration of the DALI groups
- Up to 3 push-button inputs
- Flexible assignment of the push-buttons to the desired light channel using remote control
- Calibrated 3 channels light measurement

### Product selection

Installation type	Channel	Detection range	Colour	Type	Article number
Ceiling installation	3 channels addressable	Ø 24 m	White	theRonda P360-330 DALI UP WH	2080045
			Grey	theRonda P360-330 DALI UP GR	2080046
	1 channel Broadcast	Ø 24 m	White	theRonda P360-110 DALI UP WH	2080040
			Grey	theRonda P360-110 DALI UP WH	2080041
	1 channel Broadcast	Ø 8 m	White	theRonda S360-110 DALI UP WH	2080580
			Grey	theRonda S360-110 DALI UP WH	2080581

### Technical data

	theRonda P360-330 DALI UP	theRonda P360-110 DALI UP	theRonda S360-110 DALI UP
Operating voltage	110–230 V AC		
Frequency	50–60 Hz		
Installation height	2–10 m		2–4 m
Minimum height	> 1,7 m		
Power consumption	0,3 W		
Setting range brightness	10–3000 lx / measurement off		
Light switch-off delay	10 s–60 min		
Stand-by time light	0 s–60 min/on		
Stand-by brightness	1–25 %		
Control output	100 mA		
Size of concealed housing	Ø 55 mm (NIS, PMI)		
Ambient temperature	–15 °C ... +50 °C		
Type of protection	IP 54 (when fitted)		

Detection range theRonda P (Round)

Mounting height (A)	Sitting (S)	Walking diagonally (T)	Walking head on to
2 m	16 m <sup>2</sup>   4,5 m	380 m <sup>2</sup>   22 m	28 m <sup>2</sup>   6 m
2,5 m	24 m <sup>2</sup>   5,5 m	415 m <sup>2</sup>   23 m	38 m <sup>2</sup>   7 m
3 m	28 m <sup>2</sup>   6 m	452 m <sup>2</sup>   24 m	50 m <sup>2</sup>   8 m
3,5 m	38 m <sup>2</sup>   7 m	452 m <sup>2</sup>   24 m	50 m <sup>2</sup>   8 m
6 m	-	452 m <sup>2</sup>   24 m	50 m <sup>2</sup>   8 m
10 m	-	491 m <sup>2</sup>   25 m	50 m <sup>2</sup>   8 m

With a mounting height of more than 3.5 m walking motions are necessary and the detection areas of several detectors should overlap in the marginal zone. All figures are up to values. The detection range decreases with increasing temperatures.

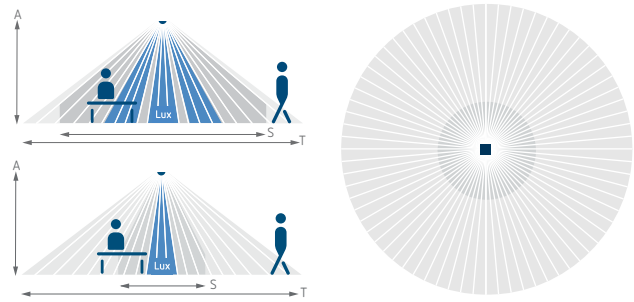

Detection range theRonda S (Round)

Mounting height (A)	Walking (T)	Sitting (S)
2 m	38 m <sup>2</sup>   7 m	5 m <sup>2</sup>   2,5 m
2,5 m	38 m <sup>2</sup>   7 m	7 m <sup>2</sup>   3 m
3 m	50 m <sup>2</sup>   8 m	13 m <sup>2</sup>   4 m
3,5 m	50 m <sup>2</sup>   8 m	-
4 m	64 m <sup>2</sup>   9 m	-

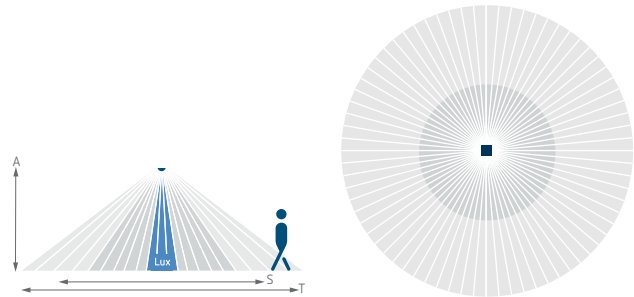

Accessories



SendoPro 868-A  
↳ Art.No.: 9070675  
Details page 339

Surface frame 110A  
Details page 337

theSenda S/P  
Details page 341

Ceiling installation box 73A  
Details page 337

Masking clip  
Details page 337

QuickSafe  
Details page 338

Scale drawings

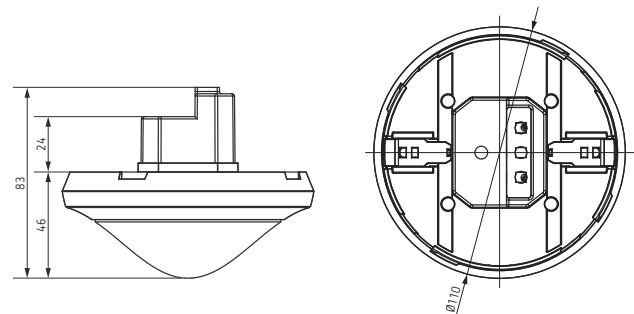

Connection diagrams

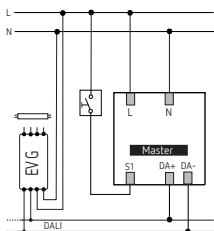

theRonda S360-110 DALI UP,  
theRonda P360-110 DALI UP,

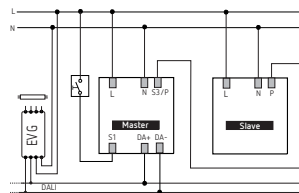

theRonda S360-110 DALI UP,  
theRonda P360-110 DALI UP,

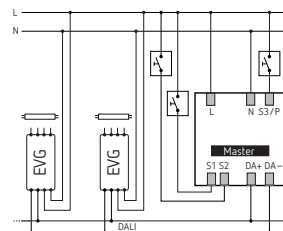

theRonda P360-330 DALI UP

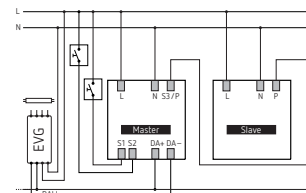

theRonda P360-330 DALI UP

# Presence and motion detectors

## Presence detectors, DALI



### Description

- Passive infrared presence detector for mounting in suspended ceilings
  - Detection area: 360°, square (up to 64 sqm) for easy and reliable planning
  - Higher flexibility due to two detection areas, different in size
  - Detection of brightness and presence for automatic control of lighting and HVAC
  - Triple light measurement (mixed light), suitable for fluorescent lamps, halogen- / incandescent lamps and LEDs
  - Totally flat design, cover frames changeable in form, colour and material
  - Optical system can be swiveled for adjusting detection area
  - Test mode for verification of function and detection area
  - Adjustable detection sensitivity
  - Setting of parameters via DALI-bus or remote control
  - Management remote control (optional)
- PlanoSpot DALI is configured as a sensor only
  - It cannot control loads, process events or make any bus configurations (addressing, binding)
  - Configuring the PlanoSpot DALI via the DALI bus therefore requires a commissioning device which supports the functionality of PlanoSpot DALI
  - Detection area, detection sensitivity and room factor may be optionally configured by means of the SendoPro management remote control

## 7

### Product selection

Installation type	Colour	Type	Article number
Ceiling installation	White	PlanoSpot 360 DALI DE WH	2030110

### Technical data

	PlanoSpot 360 DALI DE WH
Installation height	2 – 3,5 m
Minimum height	> 1,7 m
Measurement range brightness	10 – 10000 lx
Light switch-off delay	10 s – 60 min
Ambient temperature	0 °C ... +50 °C
Type of protection	IP 20

Detection range (Square)

Detection zone standard		
Mounting height (A)	Sitting (S)	Walking (T)
2 m	9 m <sup>2</sup>   3 m x 3 m	20 m <sup>2</sup>   4,5 m x 4,5 m ± 0,5 m
2,5 m	16 m <sup>2</sup>   4 m x 4 m	36 m <sup>2</sup>   6 m x 6 m ± 0,5 m
3 m	20 m <sup>2</sup>   4,5 m x 4,5 m	49 m <sup>2</sup>   7 m x 7 m ± 1 m
3,5 m	–	64 m <sup>2</sup>   8 m x 8 m ± 1 m

Detection zone reduced		
Mounting height (A)	Sitting (S)	Walking (T)
2 m	4 m <sup>2</sup>   2 m x 2 m	4,4 m <sup>2</sup>   2,1 m x 2,1 m ± 0,5 m
2,5 m	6,3 m <sup>2</sup>   2,5 m x 2,5 m	9 m <sup>2</sup>   3 m x 3 m ± 0,5 m
3 m	9 m <sup>2</sup>   3 m x 3 m	14,4 m <sup>2</sup>   3,8 m x 3,8 m ± 1 m
3,5 m	–	22,1 m <sup>2</sup>   4,7 m x 4,7 m ± 1 m

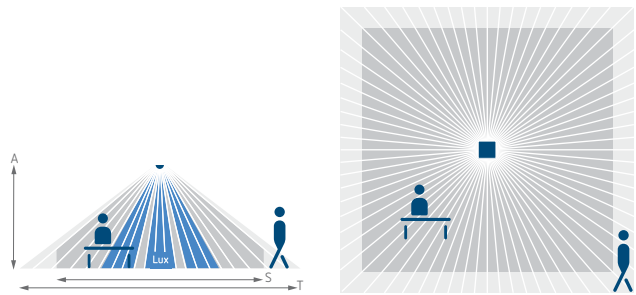

Accessories



Surface frame 75A WH  
↳ Art.No.: 9070949  
Details page 337



SendoPro 868-A  
↳ Art.No.: 9070675  
Details page 339

Surface frame 75A BK  
Details page 337

Surface frame 75A SR  
Details page 337

PlanoCover 76 BK  
Details page 338

PlanoCover 76 SR  
Details page 338

Scale drawings

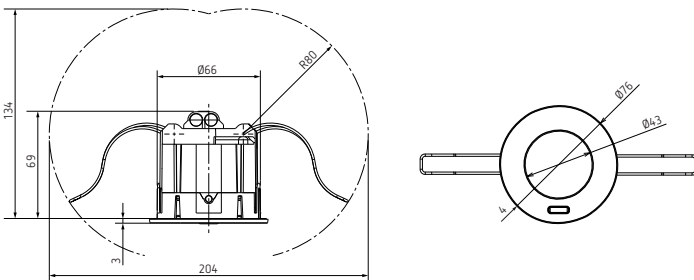

# Presence and motion detectors

## Presence detectors, LON



### Description

- Passive infrared presence detector for flush/surface mounting
- Square detection area 360° (up to 64 m<sup>2</sup>) for accurate and easy planning
- Cover frame in white included in delivery, cover frames in black or silver available as optional accessories
- Automatic presence- and brightness-dependent control for lighting and HVAC
- Mixed light measurement suitable for fluorescent lamps (FL/PL/ESL), halogen/ incandescent lamps and LEDs
- 2 independent constant light controllers #3050 for controlling two light groups
- 3 x occupancy controller #3071
- Light sensor #1010
- Occupancy sensor #1060
- Plug-in for convenient adjustment of parameters and functionality
- Brightness set point value can be set via network variables
- Scene Panel #3250 can be used with the theSenda S user remote control
- Integrated scene module (Scene controller #3251)
- Parallel switching of multiple presence detectors without logic modules
- Adjustable sensitivity
- Can be configured remotely
- SendaPro management remote control (optional)
- theSenda S user remote control (optional)
- LONMARK certified

### Product selection

Installation type	Channel	Operating voltage	Colour	Type	Article number
Ceiling installation	LON	24 V AC/DC	Pure white (similar to RAL 9010)	PresenceLight 360 PLLON WH	2009100

### Technical data

	PresenceLight 360 PLLON WH
Topology	LON FTT
Operating voltage	24 V AC/DC   AC +10 % / -20 %   DC ±20 %
Power consumption	30 mA
Installation height	2–3,5 m
Minimum height	> 1,7 m
Setting range brightness	5–2000 lx / measurement off
Light switch-off delay	10 s–100 min
Stand-by time light	30 s–60 min, on, inactive, always on
Stand-by brightness	1–25 %
Switch-on delay presence	10 s–30 min / inactive
Ambient temperature	-10 °C ... +50 °C
Type of protection	IP 54

### Detection range (Square)

Mounting height (A)	Walking (T)	Sitting (S)
2 m	20 m <sup>2</sup>   4,5 m x 4,5 m ± 0,5 m	9 m <sup>2</sup>   3 m x 3 m
2,5 m	36 m <sup>2</sup>   6 m x 6 m ± 0,5 m	16 m <sup>2</sup>   4 m x 4 m
3 m	49 m <sup>2</sup>   7 m x 7 m ± 1 m	20 m <sup>2</sup>   4,5 m x 4,5 m
3,5 m	64 m <sup>2</sup>   8 m x 8 m ± 1 m	–

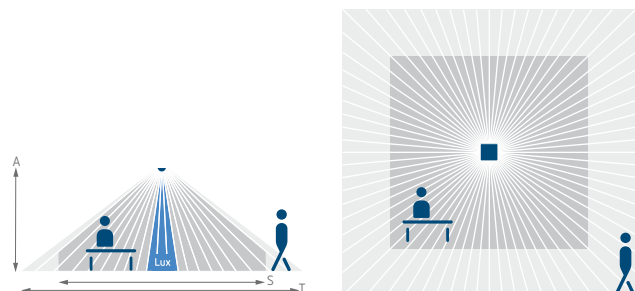

Accessories



Surface frame PresenceLight  
↳ Art.No.: 9070513  
Details page 336



SendoPro 868-A  
↳ Art.No.: 9070675  
Details page 339



theSenda S  
↳ Art.No.: 9070911  
Details page 341



theSenda P  
↳ Art.No.: 9070910  
Details page 341



QuickSafe  
↳ Art.No.: 9070531  
Details page 338

Surface frame PresenceLight BK  
Details page 336

Surface frame PresenceLight SR  
Details page 336

Ceiling installation box 73A  
Details page 337

Cover frame PresenceLight 360 SR  
Details page 336

Cover frame PresenceLight 360 BK  
Details page 336

Scale drawings

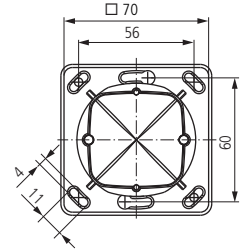
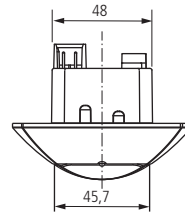
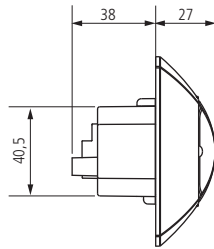
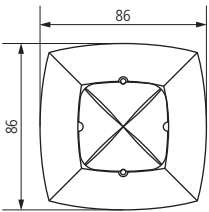

# Presence and motion detectors

## Presence detectors, LON



### Description

- Passive infrared presence detector for ceiling installation
- Flat design with interchangeable bezel frame in different colours
- Cover frame in white included in delivery, cover frames in black or silver available as optional accessories
- Square detection area 360° (up to 64 m<sup>2</sup>) for reliable and easy planning
- Automatic presence- and brightness-dependent control for lighting and HVAC
- Two differently sized detection zones for greater flexibility. Adjustable via parameters or remote control.
- Manual alignment of the detection area (swivel mechanism)
- Mixed light measurement in 3 ways suitable for fluorescent lamps (FL/PL/ESL), halogen/incandescent lamps and LEDs
- 3 x light sensor #1010
- Detection and sending of current brightness
- Setting the room correction factor for brightness measurement calibration
- 2 x constant light controller #3050 for controlling two lighting groups
- Switching or constant light control with standby function (orientation light)
- Switching mode with dimmable lighting
- Fully or semi-automatic
- Brightness switching value or setpoint value can be set in lux via plug-in, network variable or remote control
- Teach-in of the brightness switching value or the setpoint value
- Self-learning time delay can be set via plug-in, network variable or remote control
- Reduction of time delay when present briefly (short-term presence)
- Manual override by network variable, or remote control
- 3 x occupancy controller #3071
- Occupancy sensor #1060
- Switch-on delay and configurable
- Separate disable objects for light and presence outputs
- Configurable sensitivity of motion detection
- Test mode for checking function and detection area
- Scene panel #3250 can be used with the user remote control
- Integrated scene module (Scene controller #3251)
- Parallel switching of multiple presence detectors (master/slave or master/master)
- Installation in false ceilings with springs
- Surface mounting on ceilings possible with back box (optional)
- User remote control «theSenda S» (optional)
- Management remote control «SendoPro» (optional)
- Installation remote control «theSenda P» (optional)
- Standardised LONMARK objects
- Plug-in for convenient adjustment of parameters and functionality

7

### Product selection

Installation type	Colour	Type	Article number
Ceiling installation	Pure white (similar to RAL 9010)	PlanoSpot 360 PSLON DE WH	2039200

### Technical data

	PlanoSpot 360 PSLON DE
Topology	LON FTT
Operating voltage	24 V AC/DC   AC +10 % / -20 %   DC ±20 %
Power consumption	30 mA
Installation height	2–3,5 m
Minimum height	> 1,7 m
Setting range brightness	10–3000 lx / measurement off
Light switch-off delay	10 s–100 min
Stand-by time light	30 s–60 min, on, inactive, always on
Stand-by brightness	1–25 %
Switch-on delay presence	10 s–30 min / inactive
Ambient temperature	0 °C ... +50 °C
Type of protection	IP 20

Detection range (Square)

Detection zone standard		
Mounting height (A)	Sitting (S)	Walking (T)
2 m	9 m <sup>2</sup>   3 m x 3 m	20 m <sup>2</sup>   4,5 m x 4,5 m ± 0,5 m
2,5 m	16 m <sup>2</sup>   4 m x 4 m	36 m <sup>2</sup>   6 m x 6 m ± 0,5 m
3 m	20 m <sup>2</sup>   4,5 m x 4,5 m	49 m <sup>2</sup>   7 m x 7 m ± 1 m
3,5 m	–	64 m <sup>2</sup>   8 m x 8 m ± 1 m

Detection zone reduced		
Mounting height (A)	Sitting (S)	Walking (T)
2 m	4 m <sup>2</sup>   2 m x 2 m	4,4 m <sup>2</sup>   2,1 m x 2,1 m ± 0,5 m
2,5 m	6,3 m <sup>2</sup>   2,5 m x 2,5 m	9 m <sup>2</sup>   3 m x 3 m ± 0,5 m
3 m	9 m <sup>2</sup>   3 m x 3 m	14,4 m <sup>2</sup>   3,8 m x 3,8 m ± 1 m
3,5 m	–	22,1 m <sup>2</sup>   4,7 m x 4,7 m ± 1 m

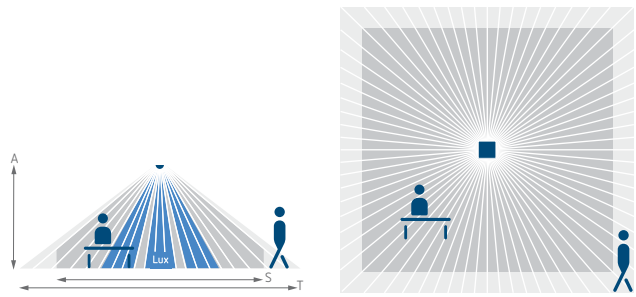

Accessories



Surface frame 75A WH  
↳ Art.No.: 9070949  
Details page 337



SendoPro 868-A  
↳ Art.No.: 9070675  
Details page 339

Surface frame 75A BK  
Details page 337

Surface frame 75A SR  
Details page 337

PlanoCover 76 BK  
Details page 338

PlanoCover 76 SR  
Details page 338

theSenda P  
Details page 341

theSenda S  
Details page 341

Scale drawings

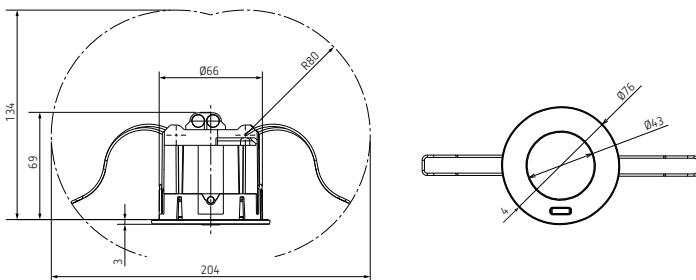

# Presence and motion detectors

## Presence detectors, LON



### Description

- Passive infrared presence detector for ceiling installation and flush/surface mounting
- Square detection area 360° (up to 100 m²) for accurate and easy planning
- Automatic presence- and brightness-dependent control for lighting and HVAC
- Flat design
- Cover frame in white included in delivery, cover frames in black or silver available as optional accessories
- 3 x mixed light measurement suitable for fluorescent lamps (FL/PL/ESL), halogen/ incandescent lamps and LEDs
- 2 independent constant light controllers #3050 for controlling two light groups
- Switching or constant light control with standby function
- Fully or semi-automatic function mode
- 3 x occupancy controller #3071
- for controlling the constant light controller or use as presence channels
- 3 x light sensor #1010
- Occupancy sensor #1060
- Plug-in for convenient adjustment of parameters and functionality
- Brightness set point value can be set via network variables
- Scene Panel #3250 can be used with the theSenda S user remote control
- Integrated scene module (Scene controller #3251)
- Parallel switching of multiple presence detectors without logic modules
- Adjustable sensitivity
- Can be configured remotely and selection of set parameters
- SendoPro management remote control (optional)
- theSenda S user remote control (optional)
- LONMARK certified

#### PlanoCentro EWH PCLON

- For ceiling installation (false ceilings), with installation for false ceilings and cover

#### PlanoCentro UWH PCLON

- For flush-mounting (concrete ceiling), with metal installation frame for screwed fixing in wooden ceilings or in flush-mounted sockets, incl. cover

7

### Product selection

Installation type	Colour	Type	Article number
Ceiling mounting with mounting frame	Pure white (similar to RAL 9010)	PlanoCentro EWH PCLON	2069102
Ceiling installation (flush-mounting concrete)	Pure white (similar to RAL 9010)	PlanoCentro UWH PCLON	2069202

### Technical data

	PlanoCentro PCLON
Topology	LON FTT
Operating voltage	24 V AC/DC   AC +10 % / -20 %   DC ±20 %
Power consumption	30 mA
Installation height	2 – 3 m
Minimum height	> 1,7 m
Setting range brightness	10 – 2000 lx / measurement off
Light switch-off delay	10 s – 100 min
Stand-by time light	30 s – 60 min, on, inactive, always on
Stand-by brightness	1 – 25 %
Switch-on delay presence	10 s – 30 min / inactive
Ambient temperature	0 °C ... +50 °C
Type of protection	IP 40 (when mounted)

Detection range (Square)

Mounting height (A)	Walking (T)	Sitting (S)
2 m	36 m <sup>2</sup>   6 m x 6 m ± 0,5 m	20 m <sup>2</sup>   4,5 m x 4,5 m
2,5 m	64 m <sup>2</sup>   8 m x 8 m ± 0,5 m	36 m <sup>2</sup>   6 m x 6 m
3 m	81 m <sup>2</sup>   9 m x 9 m ± 1 m	49 m <sup>2</sup>   7 m x 7 m
3,5 m	100 m <sup>2</sup>   10 m x 10 m ± 1 m	64 m <sup>2</sup>   8 m x 8 m

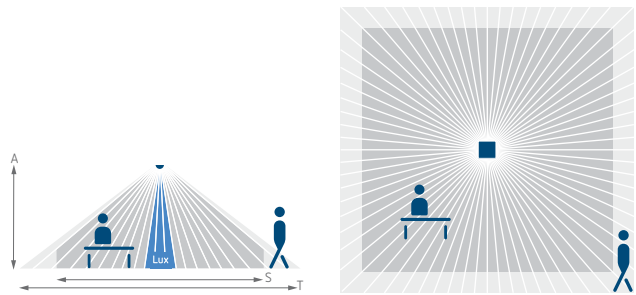

Accessories



**PlanoSets**  
for PlanoCentro-E  
↳ Art.No.: 9070736  
Details page 338



**theSenda S**  
↳ Art.No.: 9070911  
Details page 341



**SendoPro 868-A**  
↳ Art.No.: 9070675  
Details page 339

**theSenda P**  
Details page 341  
**Junction casing,**  
115 x 115 x 100 mm  
for PlanoCentro U  
Details page 338

**PlanoBox**  
for PlanoCentro U  
Details page 338

**QuickSafe**  
Details page 338

**PlanoCover 112 x 112**  
for PlanoCentro E  
Details page 338

**PlanoCover 123 x 123**  
for PlanoCentro U  
Details page 338

7

Scale drawings

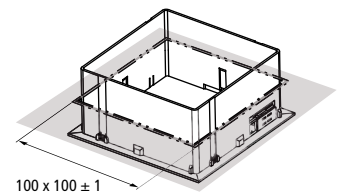
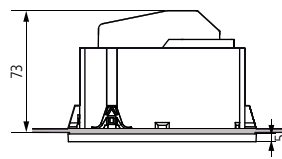
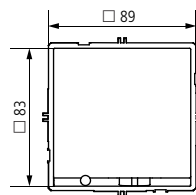
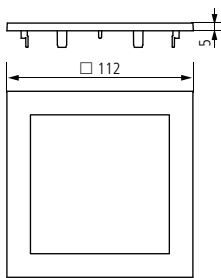

PlanoCentro E

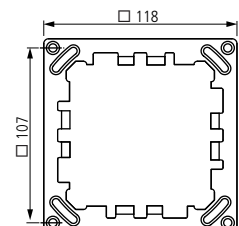
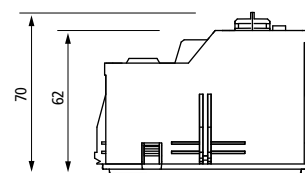
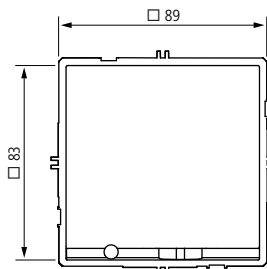
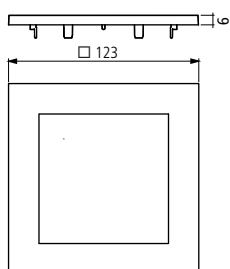

PlanoCentro U

# Presence and motion detectors

## Presence detectors, LON



### Description

- Passive infrared presence detector for wall mounting
- Detection area 180° (up to 100 m²)
- Cover frame in white included in delivery, cover frames in black or silver available as optional accessories
- Automatic presence- and brightness-dependent control for lighting and HVAC
- Mixed light measurement suitable for fluorescent lamps (FL/PL/ESL), halogen/ incandescent lamps and LEDs
- 2 independent constant light controllers #3050 for controlling two light groups
- 3 x occupancy controller #3071
- Light sensor #1010
- Occupancy sensor #1060
- Plug-in for convenient adjustment of parameters and functionality
- Brightness set point value can be set via network variables
- Scene Panel #3250 can be used with the theSenda S user remote control
- Integrated scene module (Scene controller #3251)
- Parallel switching of multiple presence detectors without logic modules
- Adjustable sensitivity
- Can be configured remotely
- SendaPro management remote control (optional)
- theSenda S user remote control (optional)
- LONMARK certified

### Product selection

Installation type	Channel	Operating voltage	Colour	Type	Article number
Wall installation	LON	24 V AC/DC	Pure white (similar to RAL 9010)	PresenceLight 180 PLLON WH	2009150

7

### Technical data

	PresenceLight 180 PLLON WH
Topology	LON FTT
Operating voltage	24 V AC/DC   AC +10 % / -20 %   DC ±20 %
Power consumption	30 mA
Installation height	1,7–2,2 m
Setting range brightness	5–2000 lx / measurement off
Stand-by time light	30 s–60 min, on, inactive, always on
Stand-by brightness	1–25 %
Light switch-off delay	10 s–100 min
Switch-on delay presence	10 s–30 min/inactive
Ambient temperature	-10 °C ... +50 °C
Type of protection	IP 54

### Detection range (Semicircular)

Mounting height (A)	Walking (T)	Sitting (S)
2,2 m	100 m <sup>2</sup>   8 m	25 m <sup>2</sup>   7 m x 3,5 m

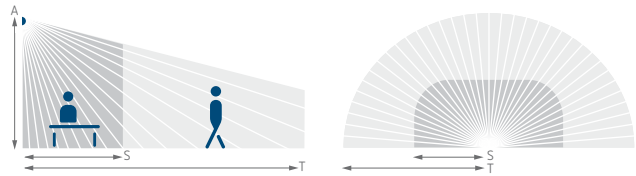

### Accessories



Surface frame PresenceLight

↳ Art.No.: 9070513

Details page 336



SendoPro 868-A

↳ Art.No.: 9070675

Details page 339



theSenda S

↳ Art.No.: 9070911

Details page 341



theSenda P

↳ Art.No.: 9070910

Details page 341



QuickSafe

↳ Art.No.: 9070531

Details page 338

Surface frame PresenceLight BK

Details page 336

Surface frame PresenceLight SR

Details page 336

Ceiling installation box 73A

Details page 337

Cover frame PresenceLight 180 SR

Details page 337

Cover frame PresenceLight 180 BK





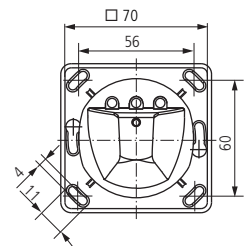
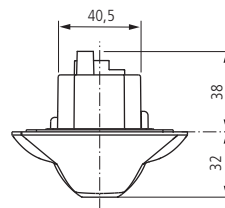
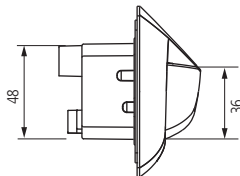
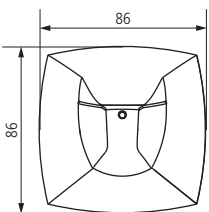

















Details page 337

### Scale drawings



# Presence and motion detectors

## Motion detectors/ Spotlights

	Installation tyoe	Detection angle	Detection range	Channel	Lamp loads	Remote controllable	Type	Page
<b>Outdoor</b>								
	Wall installation	180°	12 m	Light	2300 W	–	theLuxe E180	158
		180°	12 m	Light	2300 W	–	theLuxe R180	160
	Wall and ceiling installation	150°	12 m	Light	2300 W	–	theLuxe S150	162
		180°	12 m	Light	2300 W	–	theLuxe S180	162
		360°	16 m	Light	2300 W	–	theLuxe S360	164
	Wall and ceiling installation	220°	16 m	Light	2300 W	✓	theLuxe P220	166
		300°	16 m	Light	2300 W	✓	theLuxe P300	166
<b>Outdoor with spotlight</b>								
	Wall installation	180°	12 m	–	1000 W	–	theLeda E10/E20	168
				Light			theLeda E30	
	Wall installation	–	–	–	–	–	theLeda E10L	170
							theLeda E20L	170
							theLeda E30L	170
	Wall installation	180°	10 m	–	–	–	theLeda S10	172
							theLeda S20	172
	Wall installation	–	–	–	–	–	theLeda S10L	176
							theLeda S20L	176
	Wall installation	180°	12 m	Light	1000 W	–	LUXA 102-180 LED 32W	174
				–			–	–
	Wall installation	180°	12 m	–	–	✓	theLeda P12	178
							theLeda P24	178
	Wall installation	–	–	–	–	–	theLeda P12L	180
							theLeda P24L	180

# Presence and motion detectors

## Motion detectors/Spotlights

	Installation tyoe	Detection angle	Detection range	Channel	Lamp loads	Remote controllable	Type	Page
<b>Indoor</b>								
	Ceiling installation	360°	Ø 8 m	Light	2000 W	–	thePiccola S360-100 DE	182
				Light	2300 W	✓	theMova S360-100 DE	184
				Light   Presence	2300 W	✓	theMova S360-101 DE	184
				Light	2300 W	✓	theMova S360-100 AP	186
				Light   Presence	2300 W	✓	theMova S360-101 AP	186
			Ø 24 m	Light	2300 W	✓	theMova P360-100 UP	190
			Ø 7 m	Light	2000 W	–	LUXA 103-100 DE WH	194
			Ø 7 m	Light   Presence	2000 W	–	LUXA 103-101 DE WH	194
			Ø 7 m	Light	2000 W	–	LUXA 103-100 AP WH	194
			Ø 7 m	Light   Presence	2000 W	–	LUXA 103-101 AP WH	194
			Ø 7 m	Light	2000 W	–	LUXA 103-100 C DE WH	196
			Ø 7 m	Light   Presence	2000 W	–	LUXA 103-101 C DE WH	196
			Ø 12 m	Light	2000 W	✓	LUXA 103-100 UA WH	198
			Ø 7 m	Light	2000 W	✓	LUXA 103-100 U WH	198
	Flush-mounted wall installation	200°	8 m	Light	1000 W	–	LUXA 103-200	200
				400 W	–	LUXA 103-200 T	200	

# Presence and motion detectors

## Motion detectors, Outdoor



### Description

#### Common functions

- Motion detector (PIR)
- Automatic lighting control based on presence and brightness
- 180° detection angle
- For outdoor use
- Sensor head can be turned by  $\pm 90^\circ$  horizontally and by  $30^\circ$  downwards/upwards
- Adjustable brightness switching value and switch-off delay
- Mixed light measurement suitable for the control of fluorescent, incandescent, halogen lamps and LEDs
- Area limit via stickers
- Test function for checking detection area
- Single-handed plug-in installation

### Product selection

Installation type	Channel	Detection angle	Colour	Type	Article number
Wall installation	Light	180°	White	theLuxa E180 WH	1010205
			Black	theLuxa E180 BK	1010206

### Technical data

	theLuxa E180
Operating voltage	230 V AC
Frequency	50
Stand-by consumption	< 1 W
Setting range brightness	5 – 1000 lx
Switching capacity light	10 A (at 230 V AC, $\cos \phi = 1$ )
Detection angle	180°
Light switch-off delay	5 s – 15 min
Incandescent lamp load	2300 W
Fluorescent lamp load (conventional) parallel-corrected	350 VA, 37 $\mu$ F
Fluorescent lamp load (conventional) series-corrected	400 VA
LED lamp < 2 W	50 W
LED lamp 2 – 8 W	150 W
LED lamp > 8 W	150 W
Ambient temperature	-20 °C ... +40 °C
Protection class	II
Type of protection	IP 55

### Detection range (Semicircular)

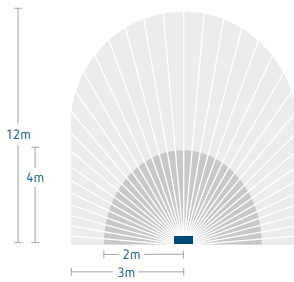

Walking diagonally to the detector  
 Walking head on to the detector  
 Mounting height: 2.5 m

### Scale drawings

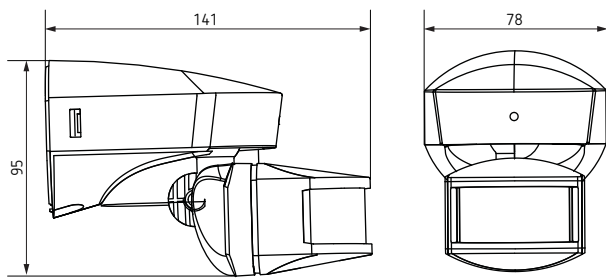

### Accessories



Corner angle theLuxe E WH  
 ↳ Art.No.: 9070974  
 Details page 339



Corner angle theLuxe E BK  
 ↳ Art.No.: 9070975  
 Details page 339

### Connection diagrams

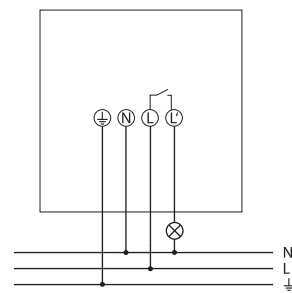

# Presence and motion detectors

## Motion detectors, Outdoor

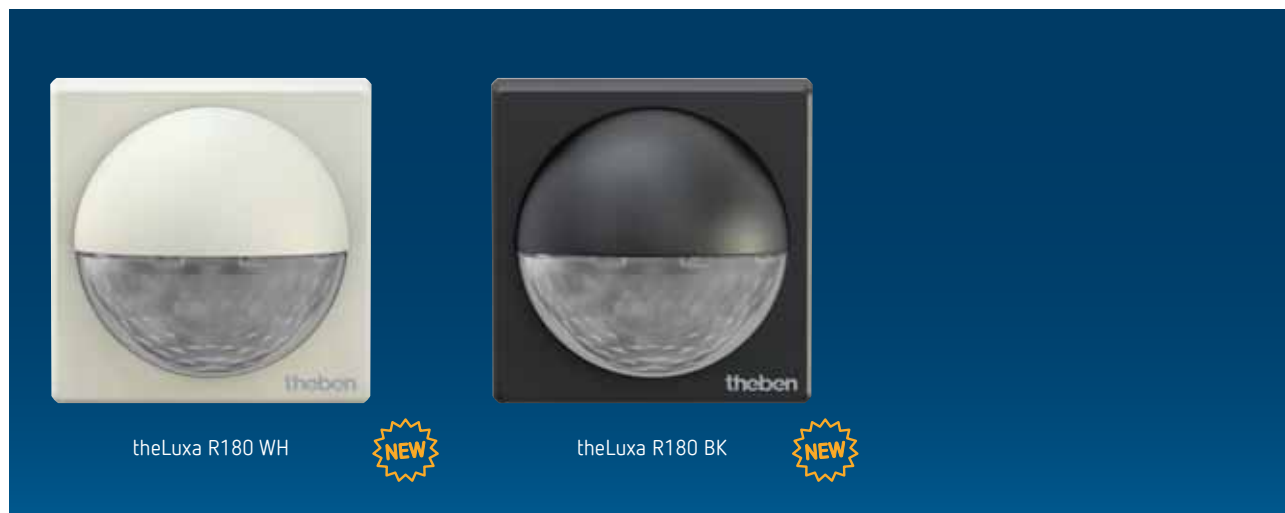

theLuxa R180 WH



theLuxa R180 BK



### Description

- Motion detector (PIR)
- Automatic lighting control based on presence and brightness
- 180° detection angle
- For outdoor use
- Protection from tampering thanks to the robust case design
- Compact dimensions
- Covered operating controls under the secured front cover
- Adjustable brightness switching value and switch-off delay
- Area limit via lens attachment
- Mixed light measurement suitable for the control of fluorescent, incandescent, halogen lamps and LEDs
- Zero-cross switching for relay-saving switching and high lamp loads
- Test function for checking detection area
- Installation on flush-mounted socket possible (60 mm)
- Single-handed plug-in installation
- Instant start-up possible via factory preset
- Terminal for protective earth conductor

8

### Product selection

Installation type	Channel	Detection angle	Colour	Type	Article number
Wall installation	Light	180°	White	theLuxa R180 WH	1010200
			Black	theLuxa R180 BK	1010201

### Technical data

	theLuxa R180 WH	theLuxa R180 BK
Operating voltage	230 V AC	
Frequency	50–60 Hz	
Stand-by consumption	< 0,5 W	
Installation height	2,5–4 m	
Detection angle	180°	
Switching capacity light	10 A (at 230 V AC, cos φ = 1)	
Setting range brightness	2–200 lx / ∞	
Light switch-off delay	2 s–30 min	
Incandescent lamp load	2300 W	
Energy saving lamps	500 W	
LED lamp < 2 W	50 W	
LED lamp > 2 W	500 W	
Ambient temperature	-25 °C ... +45 °C	
Protection class	II	
Type of protection	IP 55	

### Detection range (Semicircular)

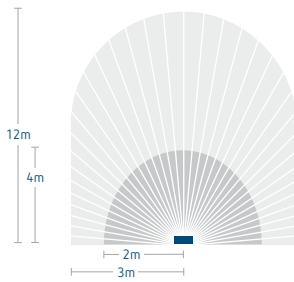

Walking diagonally to the detector  
 Walking head on to the detector  
 Mounting height: 2.5 m

### Accessories



**Corner angle 10 WH**  
 ↳ Art.No.: 9070974  
 Details page 340

**Spacer 10 WH**  
 Details page 340

**Corner angle 10 BK**  
 Details page 340

**Spacer 10 BK**  
 Details page 340

### Scale drawings

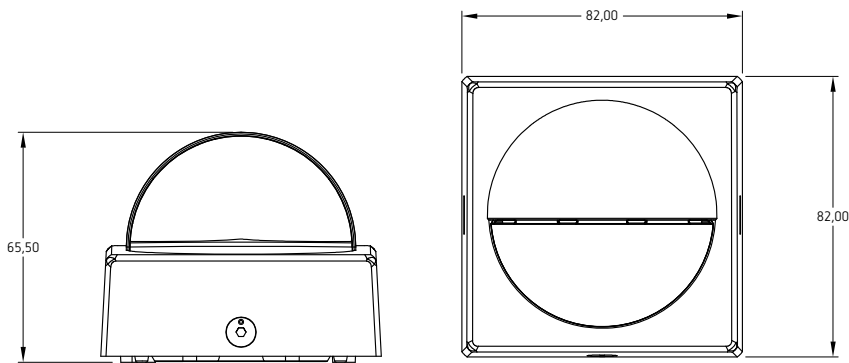

### Connection diagrams

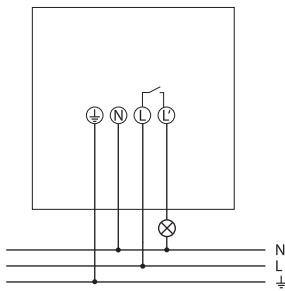

# Presence and motion detectors

## Motion detectors, Outdoor



### Description

#### Common functions

- Motion detector (PIR)
- Automatic lighting control based on presence and brightness
- For outdoor use
- Additional creep under protection
- Sensor head can be turned by  $\pm 90^\circ$  horizontally and by  $30^\circ$  downwards
- Adjustable brightness switching value and switch-off delay
- Mixed light measurement suitable for the control of fluorescent, incandescent, halogen lamps and LEDs
- Zero-cross switching for relay-saving switching and high lamp loads
- Teach-in of current brightness value possible
- Pulse function
- Test function for checking detection area
- Installation on flush-mounted socket possible (60 mm)
- Single-handed plug-in installation
- Instant start-up possible via factory preset
- Controls are place protected
- Terminal for protective earth conductor

### Product selection

Installation type	Channel	Detection angle	Colour	Type	Article number
Wall installation	Light	150°	White	theLuxa S150 WH	1010500
			Black	theLuxa S150 BK	1010501
		180°	White	theLuxa S180 WH	1010505
			Black	theLuxa S180 BK	1010506

### Technical data

	theLuxa S150	theLuxa S180
Operating voltage	230 V AC	
Frequency	50 Hz	
Stand-by consumption	0,9 W	
Setting range brightness	5 – 1000 lx	
Switching capacity light	10 A (at 230 V AC, $\cos \varphi = 1$ ), 6 A (at 230 V AC, $\cos \varphi = 0.6$ ), 3 AX (at 230 V AC, $\cos \varphi = 0.3$ )	
Detection angle	150°	180°
Light switch-off delay	1 s – 20 min	
Incandescent lamp load	2300 W	
Fluorescent lamp load (conventional) not corrected	400 VA	
Fluorescent lamp load (conventional) parallel-corrected	400 VA, 42 $\mu$ F	
Fluorescent lamp load (conventional) series-corrected	400 VA	
Energy saving lamps	150 W	
LED lamp < 2 W	25 W	
LED lamp > 2 W	200 W	

# Presence and motion detectors

## Motion detectors, Outdoor

	theLuxa S150	theLuxa S180
Ambient temperature	-25 °C ... +45 °C	
Protection class	II	
Type of protection	IP 55	

### Detection range (Semicircular)

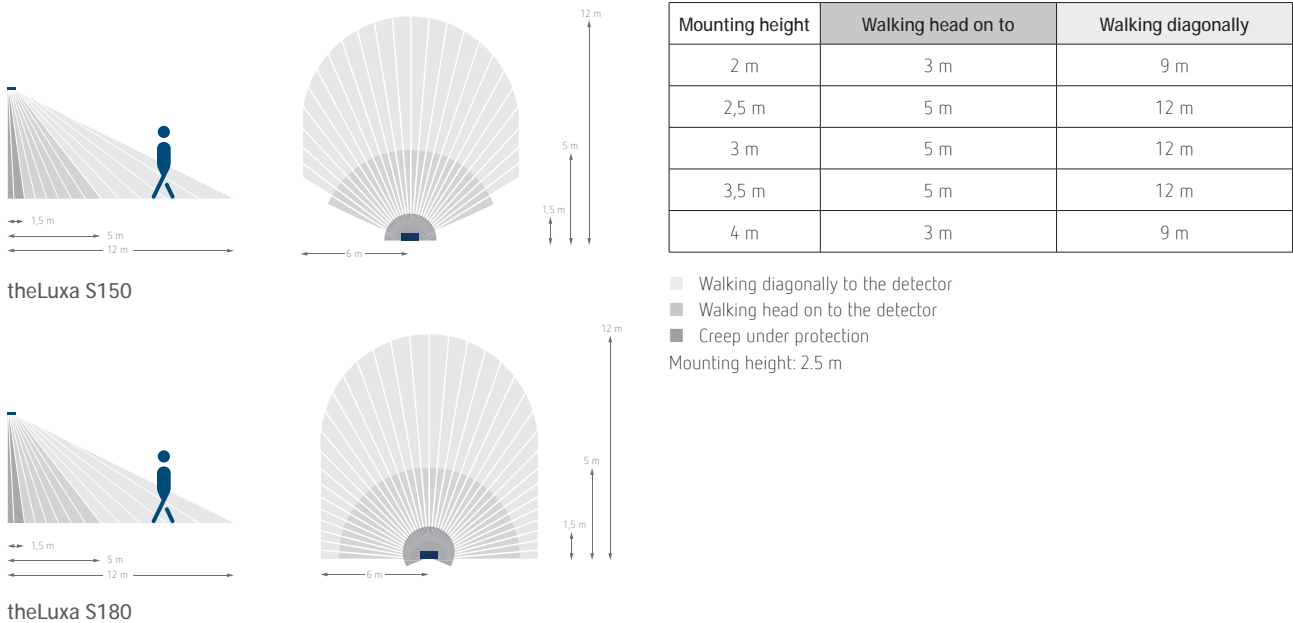

8

### Accessories



Corner angle theLuxa S WH  
↳ Art.No.: 9070902  
Details page 340



Spacer theLuxa S WH  
↳ Art.No.: 9070906  
Details page 339



Corner angle theLuxa S BK  
↳ Art.No.: 9070903  
Details page 340



Spacer theLuxa S BK  
↳ Art.No.: 9070907  
Details page 339

### Scale drawings

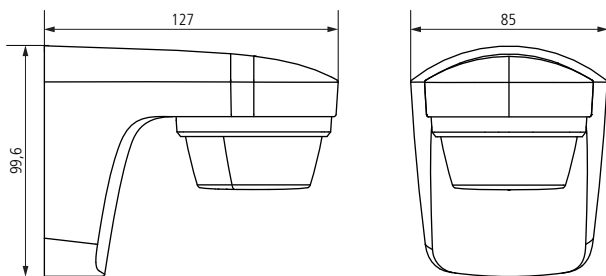

### Connection diagrams

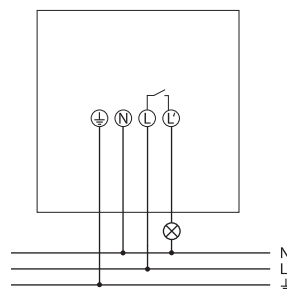

# Presence and motion detectors

## Motion detectors, Outdoor



### Description

#### Common functions

- Motion detector (PIR)
- Automatic lighting control based on presence and brightness
- For outdoor use
- For installation on walls and ceilings
- 360° detection angle
- Sensor head can be turned by  $\pm 90^\circ$  horizontally, by  $45^\circ$  downwards and by  $90^\circ$  upwards
- Adjustable brightness switching value and switch-off delay
- Sensitivity can be reduced to limit detection area
- Area limit via lens attachment
- Mixed light measurement suitable for the control of fluorescent, incandescent, halogen lamps and LEDs
- Zero-cross switching for relay-saving switching and high lamp loads
- Teach-in of current brightness value possible
- Pulse function
- Test function for checking detection area
- Installation on flush-mounted socket possible (60 mm)
- Single-handed plug-in installation
- Instant start-up possible via factory preset
- Controls are place protected
- Terminal for protective earth conductor

### Product selection

Installation type	Channel	Detection angle	Colour	Type	Article number
Wall and ceiling installation	Light	360°	White	theLuxa S360 WH	1010510
			Black	theLuxa S360 BK	1010511

### Technical data

	theLuxa S360
Operating voltage	230 V AC
Frequency	50 Hz
Stand-by consumption	0,5 W
Setting range brightness	5–1000 lx
Switching capacity light	10 A (at 230 V AC, $\cos \varphi = 1$ ), 6 A (at 230 V AC, $\cos \varphi = 0.6$ ), 3 AX (at 230 V AC, $\cos \varphi = 0.3$ )
Detection angle	360°
Light switch-off delay	1 s–20 min
Incandescent lamp load	2300 W
Fluorescent lamp load (conventional) not corrected	400 VA
Fluorescent lamp load (conventional) parallel-corrected	400 VA, 42 $\mu$ F
Fluorescent lamp load (conventional) series-corrected	400 VA
Energy saving lamps	150 W
LED lamp < 2 W	25 W
LED lamp > 2 W	200 W
Ambient temperature	-25 °C ... +45 °C
Protection class	II
Type of protection	IP 55

Detection range (Round)

Mounting height	Walking head on to	Walking diagonally
2 m	4 m	15 m
2,5 m	5 m	16 m
3 m	5 m	16 m
3,5 m	5 m	10 m
4 m	3 m	8 m

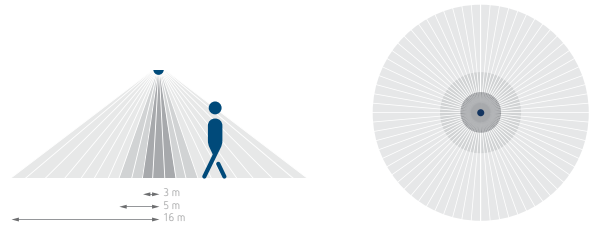

- Walking diagonally to the detector
  - Walking head on to the detector
  - Creep under protection
- Mounting height: 2.5 m

Accessories



Corner angle theLuxe S WH  
↳ Art.No.: 9070902  
Details page 340



Spacer theLuxe S WH  
↳ Art.No.: 9070906  
Details page 339



Corner angle theLuxe S BK  
↳ Art.No.: 9070903  
Details page 340



Spacer theLuxe S BK  
↳ Art.No.: 9070907  
Details page 339

Scale drawings

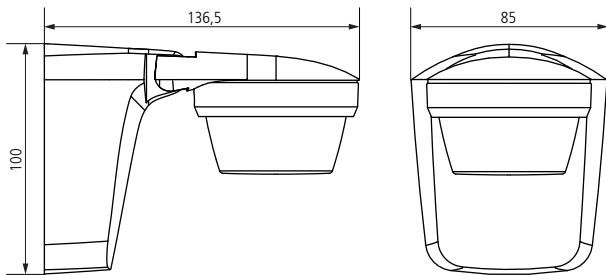

Connection diagrams

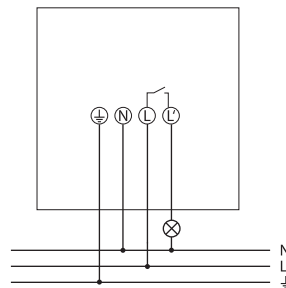

# Presence and motion detectors

## Motion detectors, Outdoor



### Description

#### Common functions

- Motion detector (PIR)
- Automatic lighting control based on presence and brightness
- For outdoor use
- For installation on walls and ceilings
- Additional creep under protection
- For larger, commercial outdoors properties such as offices, public buildings, hotels, schools, car parks and warehouses
- Adjustable brightness switching value and switch-off delay
- Sensor head can be turned by  $\pm 90^\circ$  horizontally, by  $45^\circ$  downwards and by  $90^\circ$  upwards

- Remote-controllable
- Sensitivity can be reduced to limit detection area
- Area limit via lens attachment
- Mixed light measurement suitable for the control of fluorescent, incandescent, halogen lamps and LEDs
- Potential-free relay with tungsten pre-contact for relay-saving switching and high lamp loads
- Teach-in of current brightness value possible
- Pulse function
- Test function for checking detection area

- Installation on flush-mounted socket possible (60 mm)
- Single-handed plug-in installation
- Instant start-up possible via factory preset
- Controls are place protected
- Terminal for protective earth conductor

#### theLuxa P220

- $220^\circ$  detection angle
- Spacer included in delivery

#### theLuxa P300

- $300^\circ$  detection angle
- Spacer and corner angle included in delivery

### Product selection

Installation type	Channel	Detection angle	Colour	Type	Article number
Wall and ceiling installation	Light	$220^\circ$	White	theLuxa P220 WH	1010605
			Black	theLuxa P220 BK	1010606
		$300^\circ$	White	theLuxa P300 WH	1010610
			Black	theLuxa P300 BK	1010611

### Technical data

	theLuxa P220	theLuxa P300
Operating voltage	230 V AC	
Frequency	50 Hz	
Stand-by consumption	0,3 W	
Setting range brightness	5 – 1000 lx	
Switching capacity light	10 A (at 230 V AC, $\cos \varphi = 1$ ), 10 AX (at 230 V AC, $\cos \varphi = 0.3$ )	
Detection angle	$220^\circ$	$300^\circ$
Light switch-off delay	1 s – 20 min	
Incandescent lamp load	2300 W	
Fluorescent lamp load (conventional) parallel-corrected	1300 VA, 140 $\mu$ F	
Energy saving lamps	300 W	
LED lamp < 2 W	60 W	
LED lamp > 2 W	600 W	

# Presence and motion detectors

## Motion detectors, Outdoor

	theLuxa P220	theLuxa P300
Ambient temperature	-25 °C ... +45 °C	
Protection class	II	
Type of protection	IP 55	

### Detection range (Semicircular)

Mounting height	Walking head on to	Walking diagonally
2 m	4 m	12 m
2,5 m	5 m	16 m
3 m	5 m	16 m
3,5 m	5 m	16 m
4 m	4 m	12 m

- Walking diagonally to the detector
  - Walking head on to the detector
  - Creep under protection
- Mounting height: 2.5 m

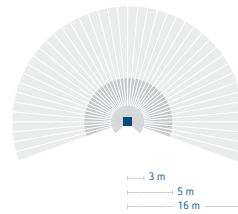

theLuxa P220

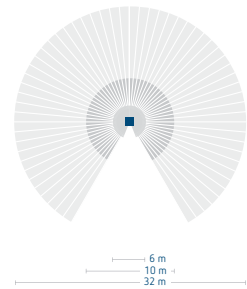

theLuxa P300

### Accessories



Corner angle theLuxa P WH

↳ Art.No.: 9070904  
Details page 340



Corner angle theLuxa P BK

↳ Art.No.: 9070905  
Details page 340



theSenda P

↳ Art.No.: 9070910  
Details page 341



Spacer theLuxa P WH

↳ Art.No.: 9070908  
Details page 339



Spacer theLuxa P BK

↳ Art.No.: 9070909  
Details page 339



theSenda S

↳ Art.No.: 9070911  
Details page 341

### Scale drawings

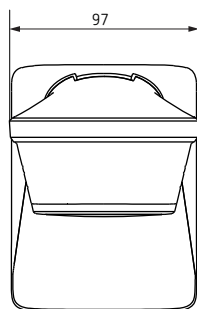
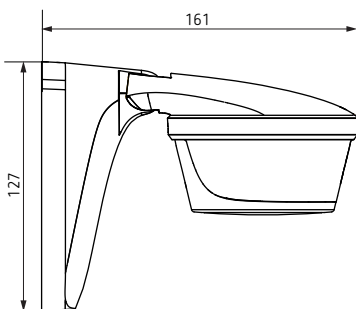

### Connection diagrams

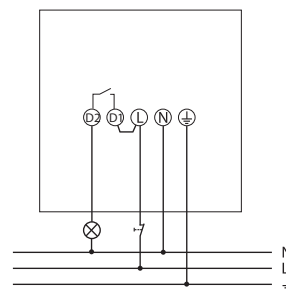

# Presence and motion detectors

## Spotlights, with motion detector



### Description

#### Common functions

- LED spotlight with motion detector
- Suitable for outdoor use
- Automatic lighting control based on presence and brightness
- 180° detection angle at a detection range of 12 m
- Sensor head can be turned by  $\pm 90^\circ$  horizontally and  $90^\circ$  downwards

- Spotlight can be swivelled  $45^\circ$  downwards and  $90^\circ$  upwards
- Area limit via stickers
- Adjustable lux value and switch-off delay
- Settings can be changed without tools
- Manually switching on possible
- Optional purely twilight-dependent control
- Not suitable for dimming application

#### theLeda E10

- LED spot with 10 W

#### theLeda E20

- LED spot with 20 W

#### theLeda E30

- LED spot with 30 W
- Additional light switch output (relay 230 V AC)

8

### Product selection

Installation type	Detection angle	LED	Colour	Type	Article number
Wall installation	180°	10 W	White	theLeda E10 WH	1020911
			Black	theLeda E10 BK	1020912
		20 W	White	theLeda E20 WH	1020913
			Black	theLeda E20 BK	1020914
		30 W	White	theLeda E30 WH	1020915
			Black	theLeda E30 BK	1020916

### Technical data

	theLeda E10 WH	theLeda E10 BK	theLeda E20 WH	theLeda E20 BK	theLeda E30 WH	theLeda E30 BK
Operating voltage	230 V AC					
Frequency	50–60 Hz					
Stand-by consumption	0,5 W					
Setting range brightness	2–200 lx					
LED output (lighting current)	750 lm	685 lm	1325 lm	1260 lm	2310 lm	2115 lm
Colour temperature	5000–5600 K					
Detection angle	180°					
Switching output	–				Not potential-free (230 V)	
Light switch-off delay	5 s–10 min					
Incandescent/halogen lamp load	–				1000 W	
LED lamp < 2 W	–				15 W	
LED lamp 2–8 W	–				50 W	

# Presence and motion detectors Spotlights, with motion detector

	theLeda E10 WH	theLeda E10 BK	theLeda E20 WH	theLeda E20 BK	theLeda E30 WH	theLeda E30 BK
LED lamp > 8 W	-				50 W	
Ambient temperature	-20 °C ... +40 °C					
Protection class	I					
Type of protection	IP 55					

## Detection range (Semicircular)

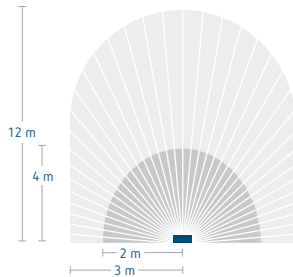

- Walking diagonally to the detector
- Walking head on to the detector

Mounting height 2.5 m

## Connection diagrams

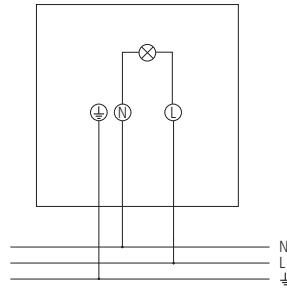

theLeda E10, theLeda E20

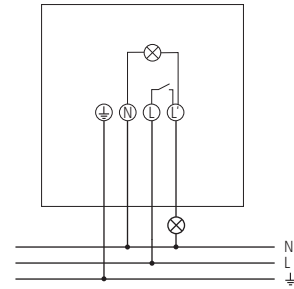

theLeda E30

## Scale drawings

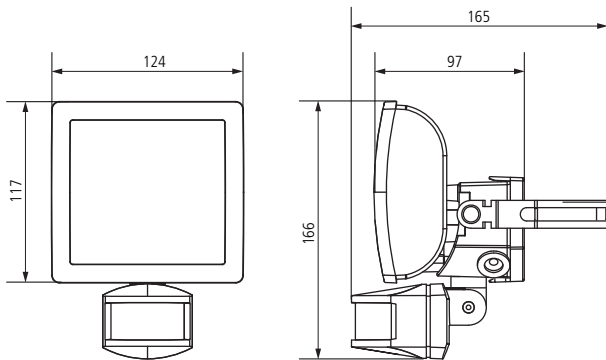

theLeda E10

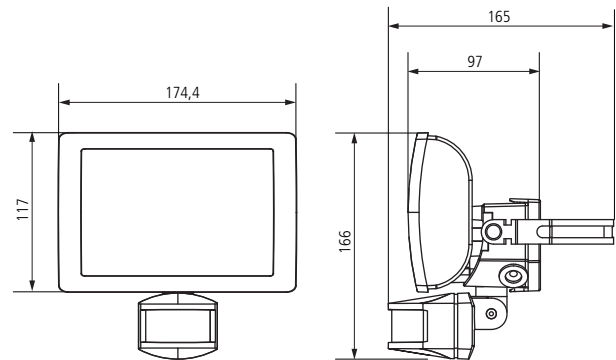

theLeda E20

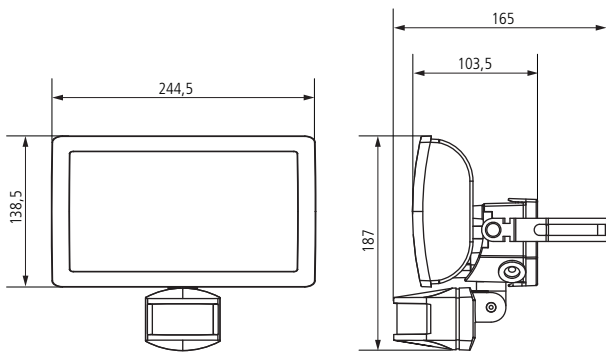

theLeda E30

# Presence and motion detectors

## Spotlights



### Description

#### Common functions

- LED spotlight
- Suitable for outdoor use
- Settings can be changed without tools

- Not suitable for dimming application

theLeda E10L

- LED spot with 10 W

theLeda E20L

- LED spot with 20 W

theLeda E30L

- LED spot with 30 W

### Product selection

Installation type	LED	Colour	Type	Article number
Wall installation	10 W	White	theLeda E10L WH	1020711
		Black	theLeda E10L BK	1020712
	20 W	White	theLeda E20L WH	1020713
		Black	theLeda E20L BK	1020714
	30 W	White	theLeda E30L WH	1020715
		Black	theLeda E30L BK	1020716

### Technical data

	theLeda E10L WH	theLeda E10L BK	theLeda E20L WH	theLeda E20L BK	theLeda E30L WH	theLeda E30L BK
Operating voltage	230 V AC					
Frequency	50–60 Hz					
LED output (lighting current)	750 lm	685 lm	1325 lm	1260 lm	2310 lm	2115 lm
Colour temperature	5000–5600 K					
Ambient temperature	–20 °C ... +40 °C					
Protection class	I					
Type of protection	IP 55					

Scale drawings

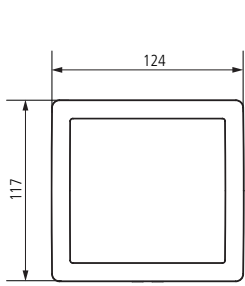

theLeda E10L

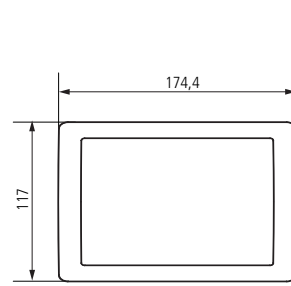
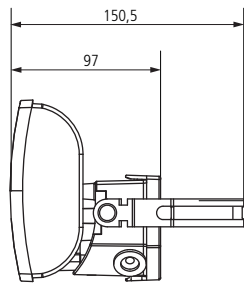

theLeda E20L

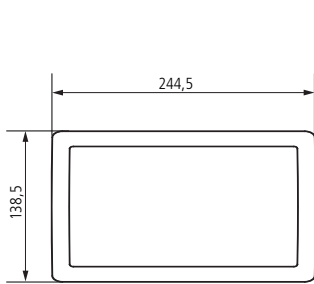
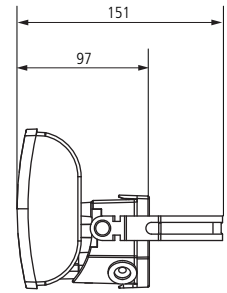

theLeda E30L

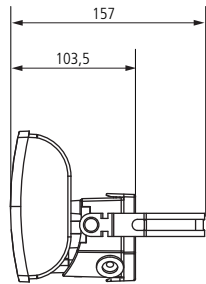

Connection diagrams

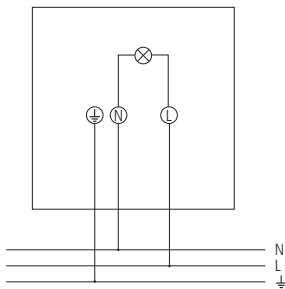

# Presence and motion detectors

## Spotlights, with motion detector



### Description

#### Common functions

- LED spotlight with motion detector
- Suitable for outdoor use
- Automatic lighting control based on presence and brightness
- 180° detection angle at a detection range of 10 m
- Area limit via lens attachment
- Orientation light with configurable dimming level

- Short and extended function via manual control system
- Integrated heat sink in housing color
- Direct-LED for maximum light output
- High-tech matrix-LED module
- Single-handed plug-in installation
- Instant start-up possible via factory preset
- Adjustable lux value and switch-off delay
- Setting elements easily accessible on the side

#### theLeda S10

- 1 LED spot with 10 W (equivalent to 140 W Halogen spotlight)
- Spotlight can be swivelled  $\pm 40^\circ$  horizontally, and adjusted  $70^\circ$  downwards, wall-wash functionality by swivelling  $180^\circ$

#### theLeda S20

- 2 LED spot with 10 W each (equivalent to 2x140 W Halogen spotlight)
- Spotlights can be swivelled  $\pm 20^\circ$  horizontally, and adjusted  $70^\circ$  downwards

### Product selection

Installation type	LED	Colour temperature	Colour	Type	Article number
Wall installation	10 W	4000 K, neutral white	White	theLeda S10 WH	1020921
			Black	theLeda S10 BK	1020922
		3000 K, warm white	White	theLeda S10 W WH	1020931
			Black	theLeda S10 W BK	1020932
	2 x 10 W	4000 K, neutral white	White	theLeda S20 WH	1020923
			Black	theLeda S20 BK	1020924
		3000 K, warm white	White	theLeda S20 W WH	1020933
			Black	theLeda S20 W BK	1020934

### Technical data

	theLeda S10	theLeda S10 W	theLeda S20	theLeda S20 W
Operating voltage	230 V AC			
Frequency	50–60 Hz			
Stand-by consumption	0,4 W			
Setting range brightness	2–200 lx			
LED output (lighting current)	840 lm		2 x 840 lm	

# Presence and motion detectors Spotlights, with motion detector

	theLeda S10	theLeda S10 W	theLeda S20	theLeda S20 W
Colour temperature	4000 K, neutral white	3000 K, warmwhite	4000 K, neutral white	3000 K, warmwhite
Detection angle	180°			
Installation height	2–4 m			
Light switch-off delay	2 s–30 min			
Ambient temperature	–20 °C ... +45 °C			
Protection class	I			
Type of protection	IP 55			

## Detection range (Semicircular)

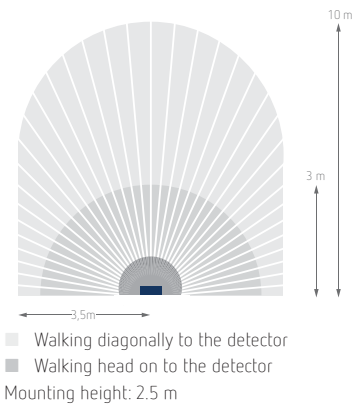

## Connection diagrams

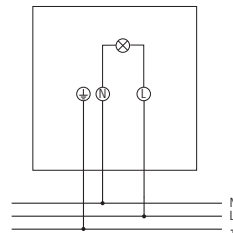

## Accessories



**Corner angle 10 WH**  
 ↳ Art.No.: 9070969  
 Details page 340



**Spacer 10 WH**  
 ↳ Art.No.: 9070971  
 Details page 340



**Corner angle 10 BK**  
 ↳ Art.No.: 9070987  
 Details page 340



**Spacer 10 BK**  
 ↳ Art.No.: 9070988  
 Details page 340

## Dimensions

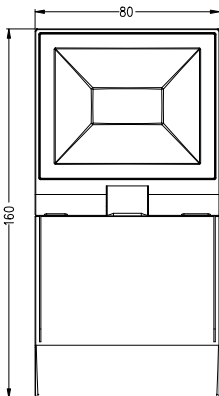

theLeda S10

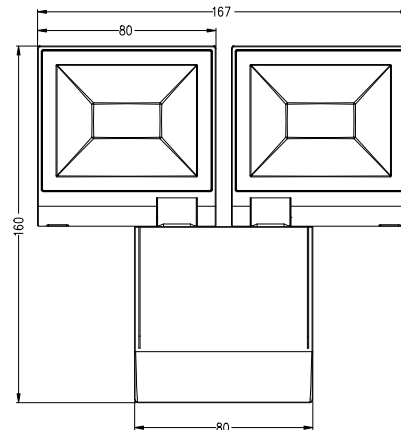
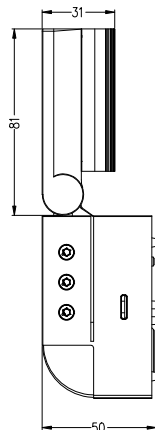

theLeda S20

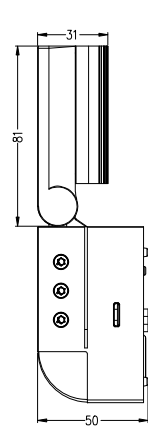

# Presence and motion detectors

## Spotlights



### Description

#### Common functions

- LED spotlight with motion detector
- 1 LED spot with 32 W (equivalent to 230 W Halogen spotlight)
- Suitable for outdoor use
- Automatic lighting control based on presence and brightness
- Additional light switch output (relay 230 V AC)

- 180° detection angle at a detection range of 12 m
- Additional creep under protection with 220° detection angle at a detection range of 1 m
- Sensor head can be turned by  $\pm 90^\circ$  horizontally
- Spotlight can be swivelled  $\pm 90^\circ$  horizontally, and adjusted  $55^\circ$  downwards
- Area limit via lens attachment
- Single-handed plug-in installation

- Instant start-up possible via factory preset
- Adjustable lux value and switch-off delay
- Settings can be changed without tools
- Optional purely twilight-dependent control
- Master/master switching
- Additional spacer included. For flexible installation (cable entry below, side, top and more space for cables) and an increased angle of rotation for spotlight
- Not suitable for dimming application

### Product selection

Installation type	Channel	Colour temperature	Colour	Type	Article number
Wall installation	Light	6000 K, daylight white	White	LUXA 102-180 LED 32W WH	1020975
			Black	LUXA 102-180 LED 32W BK	1020976

8

### Technical data

	LUXA 102-180 LED 32W
Operating voltage	220–240 V AC
Frequency	50–60 Hz
Stand-by consumption	0,5 W
Setting range brightness	5–200 lx or just presence dependent
Switching capacity light	8 AX (at 230 V AC, $\cos \varphi = 1$ ), 2,6 A (at 230 V AC, $\cos \varphi = 0.6$ )
LED output (lighting current)	32 W (2000 lm)
Colour temperature	6000 K, daylight white
Detection angle	180°
Switching output	Not potential-free (230 V)
Light switch-off delay	5 s – 10 min
Incandescent/halogen lamp load	1000 W
LED lamp < 2 W	10 W
LED lamp 2 – 8 W	25 W
Ambient temperature	–25 °C ... +45 °C
Protection class	II
Type of protection	IP 55

### Detection range (Semicircular)

Mounting height	Walking head on to	Walking diagonally
2 m	5 m	12 m
2,5 m	5 m	12 m
3 m	5 m	10 m
3,5 m	3 m	9 m
4 m	3 m	7 m

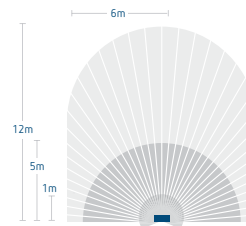

- Walking diagonally to the detector
  - Walking head on to the detector
  - Creep under protection
- Mounting height: 2.5 m

### Scale drawings

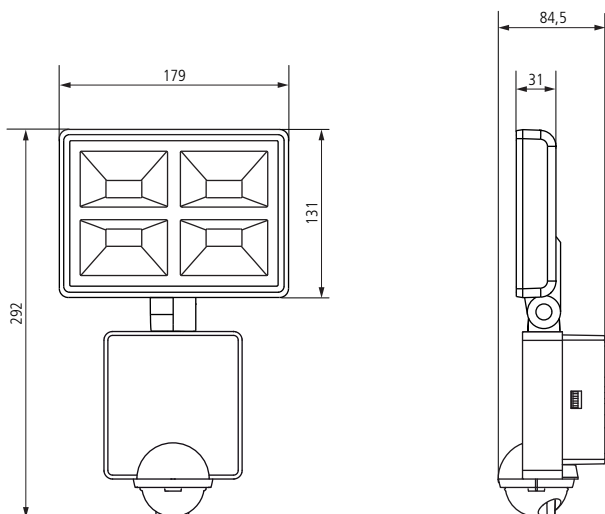

### Connection diagrams

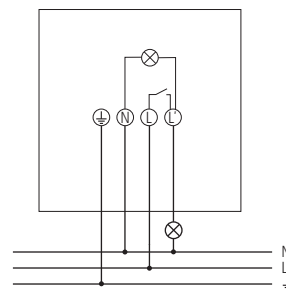

# Presence and motion detectors

## Spotlights



### Description

#### Common functions

- LED spotlight
- Suitable for outdoor use
- Single-handed plug-in installation

#### theLeda S10L

- 1 LED spot with 10 W (equivalent to 140 W Halogen spotlight)
- Spotlight can be swivelled  $\pm 40^\circ$  horizontally, and adjusted  $70^\circ$  downwards, wall-wash functionality by swivelling  $180^\circ$
- Integrated heat sink in housing color

- Direct-LED for maximum light output
- High-tech matrix-LED module

#### theLeda S20L

- 2 LED spot with 10 W each (equivalent to 2x140 W Halogen spotlight)
- Spotlights can be swivelled  $\pm 20^\circ$  horizontally, and adjusted  $70^\circ$  downwards
- Integrated heat sink in housing color
- Direct-LED for maximum light output
- High-tech matrix-LED module

#### LUXA 102 FL LED 32W

- 1 LED spot with 32 W (equivalent to 230 W Halogen spotlight)
- Additional spacer included. For flexible installation (cable entry below, side, top and more space for cables) and an increased angle of rotation for spotlight
- Spotlight can be swivelled  $\pm 90^\circ$  horizontally, and adjusted  $55^\circ$  downwards
- Instant start-up possible via factory preset
- Not suitable for dimming application

### Product selection

Installation type	LED	Colour	Type	Article number
Wall installation	10 W	White	theLeda S10L WH	1020721
		Black	theLeda S10L BK	1020722
	2 x 10 W	White	theLeda S20L WH	1020723
		Black	theLeda S20L BK	1020724
	32 W	White	LUXA 102 FL LED 32W WH	1020775
		Black	LUXA 102 FL LED 32W BK	1020776

### Technical data

	theLeda S10L	theLeda S20L	LUXA 102 FL LED 32W
Operating voltage	230 V AC		220–240 V AC
Frequency	50–60 Hz		
LED output (lighting current)	840 lm	2 x 840 lm	32 W (2000 lm)
Colour temperature	4000 K, neutral white		6000 K, daylight white
Installation height	2–4 m		
Ambient temperature	-20 °C ... +45 °C		

	theLeda S10L	theLeda S20L	LUXA 102 FL LED 32W
Protection class		II	
Type of protection		IP 55	

### Accessories (theLeda S10L and theLeda S20L)



Corner angle 10 WH  
↳ Art.No.: 9070969  
Details page 340



Spacer 10 WH  
↳ Art.No.: 9070971  
Details page 340



Corner angle 10 BK  
↳ Art.No.: 9070987  
Details page 340



Spacer 10 BK  
↳ Art.No.: 9070988  
Details page 340

### Connection diagrams

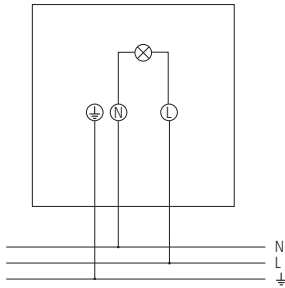

theLeda S L

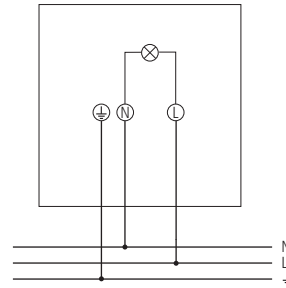

LUXA 102 FL LED 32W

### Dimensions

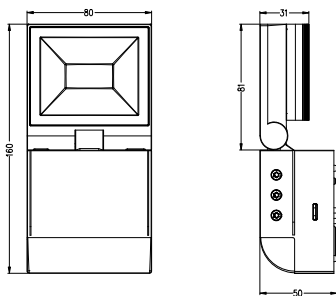

theLeda S10L

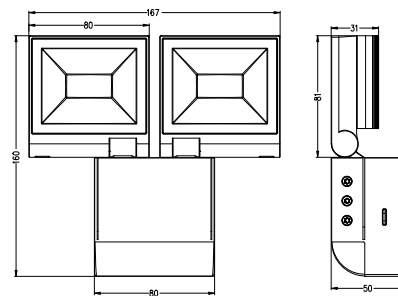

theLeda S20L

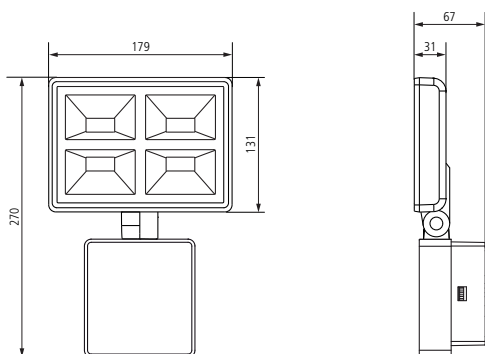

LUXA 102 FL LED 32 W

# Presence and motion detectors

## Spotlights, with motion detector



theLeda P12 WH

theLeda P24 AL

### Description

#### Common functions

- LED spotlight with motion detector
- Suitable for outdoor use
- Automatic lighting control based on presence and brightness
- 180° detection angle at a detection range of 12 m and creep under protection
- Diffused glare-free light with aura effect
- Functions teach-in, test, twilight switch, dimmable orientation light and night interruption adjustable

- Master/master switching
- Area limit via lens attachment
- Controls are place protected
- Remote controllable with optionally remote controls theSenda P and theSenda S
- Back side made of high-quality aluminum die-cast for an optimally cooling of the high-power LEDs

#### theLeda P12

- 11 W (900 lm), equivalent to 140 W Halogen spotlight

- Spotlight can be swivelled 35° left/right, 60° upwards/downwards and 180° backwards
- Spacer included in delivery

#### theLeda P24

- 20 W (2 x 900 lm), equivalent to 2 x 140 W Halogen spotlight
- Spotlight can be swivelled 30° backwards, 60° downwards
- Spacer and corner angle included in delivery

### Product selection

Installation type	LED	Colour	Type	Article number
Wall installation	11 W (900 lm)	White	theLeda P12 WH	1020941
		Aluminium	theLeda P12 AL	1020942
	20 W (2 x 900 lm)	White	theLeda P24 WH	1020943
		Aluminium	theLeda P24 AL	1020944

### Technical data

	theLeda P12	theLeda P24
Operating voltage	230 V AC	
Frequency	50–60 Hz	
Stand-by consumption	0,4 W	
Setting range brightness	5–800 lx or just presence dependent	
LED output (lighting current)	11 W (900 lm)	20 W (2 x 900 lm)
Colour temperature	4000 K, neutral white	
Detection angle	180°	
Installation height	1,8–2,5 m	
Light switch-off delay	10 s–20 min	
Ambient temperature	–25 °C ... +45 °C	
Protection class	II	
Type of protection	IP 55	

## Detection range (Semicircular)

Mounting height (A)	Head on to (r)	Diagonally (t)
2 m	5 m	12 m
2,5 m	4 m	10 m
3 m	4 m	8 m
3,5 m	4 m	6 m
4 m	2 m	4 m

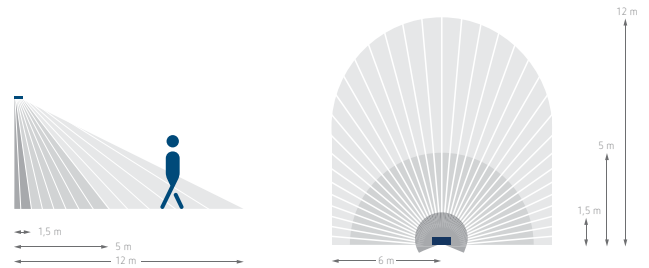

## Accessories



theSenda P  
↳ Art.No.: 9070910  
Details page 341



theSenda S  
↳ Art.No.: 9070911  
Details page 341

Corner angle 10 WH  
Details page 340

Spacer 10 WH  
Details page 340

Corner angle 10 AL  
Details page 340

Spacer 10 AL  
Details page 340

## Scale drawings

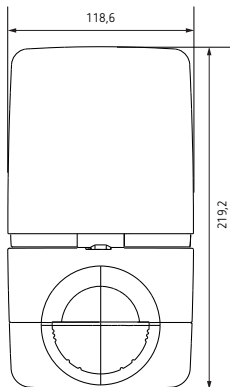

theLeda P12

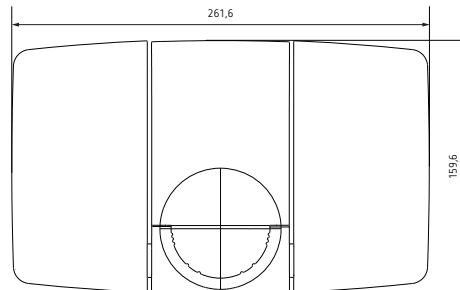
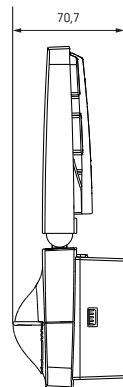

theLeda P24

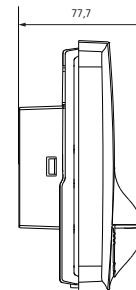

## Connection diagrams

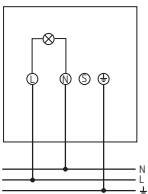

theLeda P12, theLeda P24  
(Standard operation)

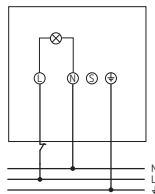

theLeda P12, theLeda P24 (Manual  
operation via circuit breaker button)

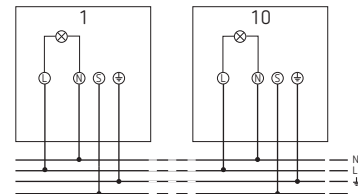

theLeda P12, theLeda P24  
(Connection Master/Master)

# Presence and motion detectors

## Spotlights



theLeda P12L WH

theLeda P24L AL

### Description

#### Common functions

- LED spotlight
- Suitable for outdoor use
- Diffused glare-free light with aura effect
- Slave-function
- Back side made of high-quality aluminium die-cast for an optimally cooling of the high-power LEDs

#### theLeda P12L

- 11 W (900 lm), equivalent to 140 W Halogen spotlight
- Spotlight can be swivelled 35° left/right, 60° upwards/downwards and 180° backwards
- Spacer included in delivery

#### theLeda P24L

- 20 W (2 x 900 lm), equivalent to 2 x 140 W Halogen spotlight
- Spotlight can be swivelled 30° backwards, 60° downwards
- Spacer and corner angle included in delivery

8

### Product selection

Installation type	LED	Colour	Type	Article number
Wall installation	11 W (900 lm)	White	theLeda P12L WH	1020741
		Aluminium	theLeda P12L AL	1020742
	20 W (2 x 900 lm)	White	theLeda P24L WH	1020743
		Aluminium	theLeda P24L AL	1020744

### Technical data

	theLeda P12L	theLeda P24L
Operating voltage	230 V AC	
Frequency	50–60 Hz	
Stand-by consumption	0,4 W	
LED output (lighting current)	11 W (900 lm)	20 W (2 x 900 lm)
Colour temperature	4000 K, neutral white	
Installation height	1,8–2,5 m	
Ambient temperature	–25 °C ... +45 °C	
Protection class	II	
Type of protection	IP 55	

Accessories



Corner angle 10 WH  
↳ Art.No.: 9070969  
Details page 340



Spacer 10 WH  
↳ Art.No.: 9070971  
Details page 340



Corner angle 10 AL  
↳ Art.No.: 9070970  
Details page 340



Spacer 10 AL  
↳ Art.No.: 9070972  
Details page 340

Scale drawings

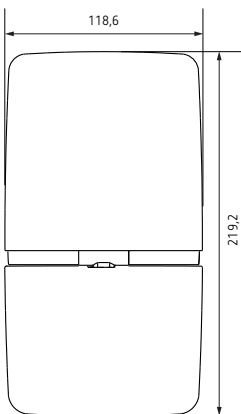

theLeda P12L

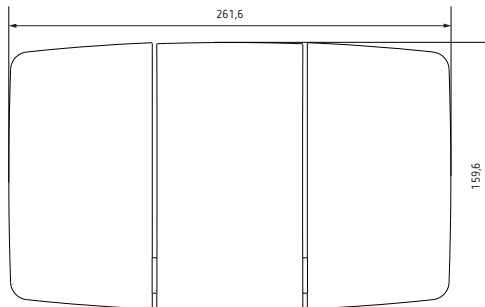
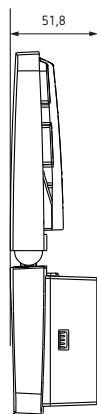

theLeda P24L

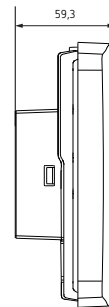

Connection diagrams

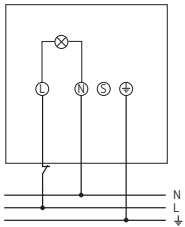

theLeda P12L, theLeda P24L

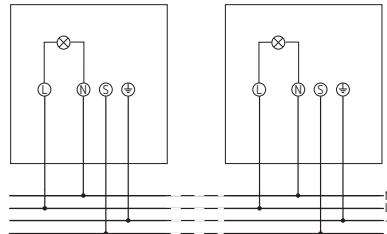

theLeda P12, theLeda P24L  
(Connection Master/Slave)

# Presence and motion detectors

## Motion detectors



### Description

- Passive infra-red motion detector for ceiling installation
- Circular detection area 360°, up to Ø 8 m (50 m<sup>2</sup>)
- Automatic motion and brightness-dependent control for lighting
- Mixed light measurement suitable for fluorescent lamps (FL/PL/ESL), halogen/ incandescent lamps and LEDs
- Channel A light: relay, 230 V
- Operation as fully automatic device
- Brightness switching value configurable, teach-in function
- Pulse function for staircase light time switch
- Time delay configurable
- Extension of detection area via Master/ Slave switching
- Test mode for checking function and detection area
- Diameter of ceiling cutout 34–36 mm
- Ready for immediate use due to factory presetting

### Product selection

Installation type	Channel	Operating voltage	Colour	Type	Article number
Ceiling installation	Light	110–240 V AC	White	thePiccola S360-100 DE WH	1060200

### Technical data

thePiccola S360-100 DE WH			
Operating voltage	110–240 V AC	Fluorescent lamp load (conventional) parallel-corrected	1300 VA, 140 µF
Frequency	50–60 Hz	Fluorescent lamp load (conventional) series-corrected	2000 VA
Installation height	2–4 m	Fluorescent lamp load (electronic ballast)	1200 W
Power consumption	0,4 W	LED lamp < 2 W	55 W
Setting range brightness	5–1000 lx	LED lamp 2–8 W	180 W
Light switch-off delay	30 s–30 min	LED lamp > 8 W	200 W
Incandescent/halogen lamp load	2000 W	Ambient temperature	–20 °C ... +50 °C
Fluorescent lamp load (conventional) not corrected	2000 VA	Type of protection	IP 21 (Sensor), IP 20 (power module)

Detection range (Round)

Mounting height (A)	Head on to (r)	Diagonally (t)
2,5 m	3 m <sup>2</sup>   2 m	50 m <sup>2</sup>   8 m

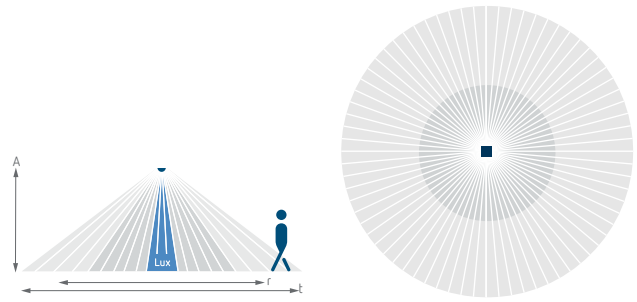

Scale drawings

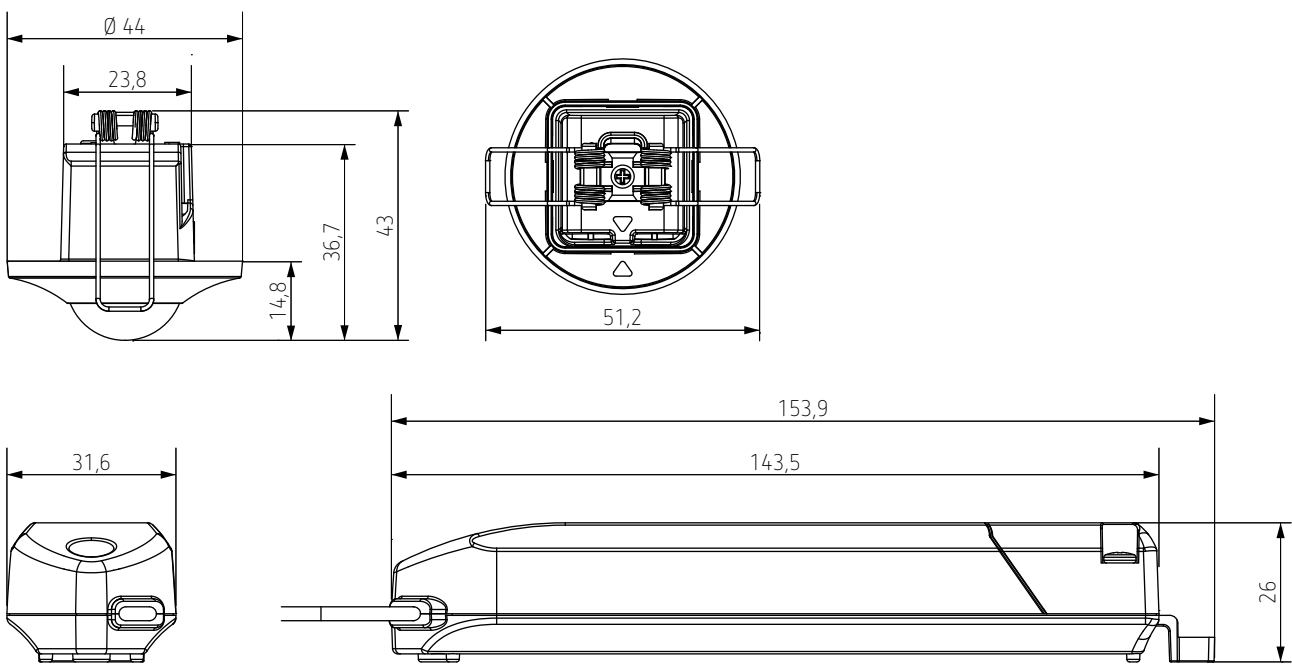

8

Connection diagrams

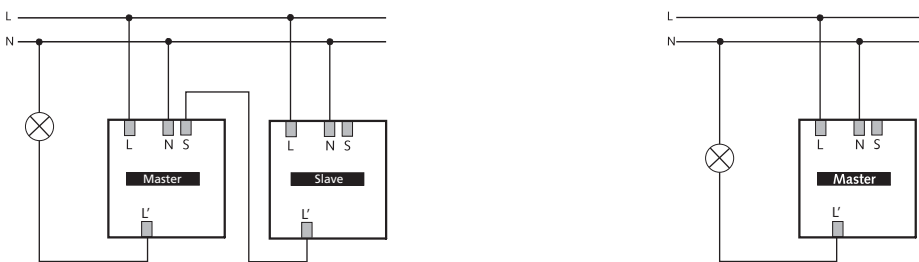

# Presence and motion detectors

## Motion detectors



### Description

- Passive infra-red motion detector for ceiling installation
  - Circular detection area 360°, up to Ø 9 m (64 m²)
  - Mixed light measurement suitable for fluorescent lamps (FL/PL/ESL), halogen/incandescent lamps and LEDs
  - Channel A light: relay, 230 V
  - Operation as fully automatic device
  - Brightness switching value configurable, teach-in function
  - Pulse function for staircase light time switch
  - Detection sensitivity configurable
  - Test mode for checking function and detection area
  - Ready for immediate use due to factory presetting (Brightness switching value 300 lux, Time delay 10 min)
- One of these optional remote controls is required for changing the values and attitudes:
    - Management remote control SendaPro
    - Installation remote control theSenda P
  - Optional user remote control:
    - theSenda S
- theMova S360-100 DE**
- 1 channel light
  - Automatic motion and brightness-dependent control for lighting
- theMova S360-101 DE**
- 1 channel light and 1 channel presence
  - Automatic motion and brightness-dependent control for lighting and HVAC
  - Channel H, presence: relay, floating e.g. for HVAC control
  - Time delay configurable

### Product selection

8

Installation type	Channel	Operating voltage	Colour	Type	Article number
Ceiling installation	Light	230 V AC	White	theMova S360-100 DE WH	1030560
			Grey	theMova S360-100 DE GR	1030561
	Light   Presence	230 V AC	White	theMova S360-101 DE WH	1030565
			Grey	theMova S360-101 DE GR	1030566

### Technical data

	theMova S360-100 DE	theMova S360-101 DE
Operating voltage	230 V AC	
Frequency	50 Hz	
Recommended installation height	2–3,5 m	
Power consumption	0,5 W	
Setting range brightness	30–3000 lx	
Light switch-off delay	10 s–60 min	
Type of contact light	Relay 230 V/10 A µ-contact	
Incandescent/halogen lamp load	2300 W	
Compact and fluorescent lamps	1150 VA (cos φ = 0,5)	
Inrush current	max. 400 A/200 µs	
LED lamp < 2 W	25 W	
LED lamp > 2 W	70 W	
Switching capacity presence	–	50 W/50 VA
Ambient temperature	–15 °C ... +50 °C	
Type of protection	IP 40 (when fitted)	

Detection range (Round)

Mounting height (A)	Head on to (r)	Diagonally (t)
2 m	5 m <sup>2</sup>   2,5 m	38 m <sup>2</sup>   7 m
2,5 m	7 m <sup>2</sup>   3 m	38 m <sup>2</sup>   7 m
3 m	13 m <sup>2</sup>   4 m	50 m <sup>2</sup>   8 m
3,5 m	13 m <sup>2</sup>   4 m	50 m <sup>2</sup>   8 m
4 m	13 m <sup>2</sup>   4 m	64 m <sup>2</sup>   9 m

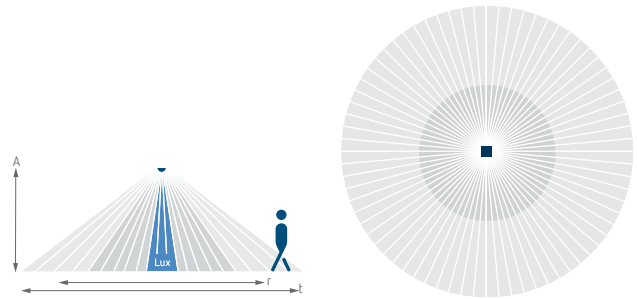

Accessories



SendoPro 868-A  
↳ Art.No.: 9070675  
Details page 339



theSenda P  
↳ Art.No.: 9070910  
Details page 341



theSenda S  
↳ Art.No.: 9070911  
Details page 341

Scale drawings

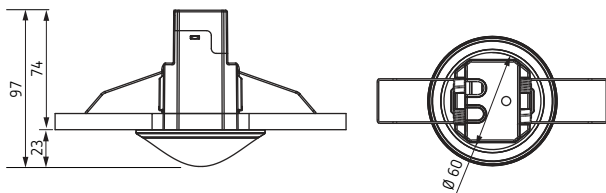

Connection diagrams

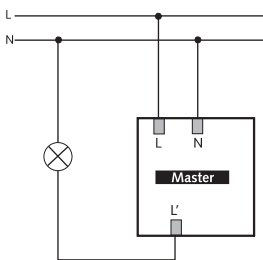

theMova S360-100 DE

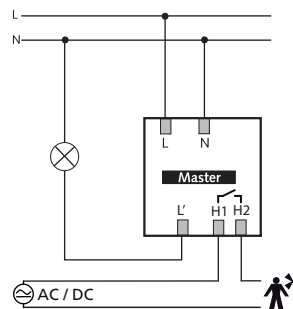

theMova S360-101 DE

# Presence and motion detectors

## Motion detectors



### Description

- Passive infra-red motion detector for ceiling installation
  - Circular detection area 360°, up to Ø 9 m (64 m<sup>2</sup>)
  - Mixed light measurement suitable for fluorescent lamps (FL/PL/ESL), halogen/ incandescent lamps and LEDs
  - Channel A light: relay, 230 V
  - Operation as fully automatic device
  - Brightness switching value configurable, teach-in function
  - Pulse function for staircase light time switch
  - Detection sensitivity configurable
  - Test mode for checking function and detection area
  - Ready for immediate use due to factory presetting (Brightness switching value 300 lux, Time delay 10 min)
- One of these optional remote controls is required for changing the values and attitudes:
    - Management remote control SendaPro
    - Installation remote control theSenda P
  - Optional user remote control:
    - theSenda S
- theMova S360-100 AP**
- 1 channel light
  - Automatic motion and brightness-dependent control for lighting
- theMova S360-101 AP**
- 1 channel light and 1 channel presence
  - Automatic motion and brightness-dependent control for lighting and HVAC
  - Channel H, presence: relay, floating e.g. for HVAC control
  - Time delay configurable

### Product selection

Installation type	Channel	Operating voltage	Colour	Type	Article number
Ceiling installation	Light	230 V AC	White	theMova S360-100 AP WH	1030550
			Grey	theMova S360-100 AP GR	1030551
	Light   Presence	230 V AC	White	theMova S360-101 AP WH	1030555
			Grey	theMova S360-101 AP GR	1030556

### Technical data

	theMova S360-100 AP	theMova S360-101 AP
Operating voltage	230 V AC	
Frequency	50 Hz	
Recommended installation height	2–3,5 m	
Power consumption	0,5 W	
Setting range brightness	30–3000 lx	
Light switch-off delay	10 s–60 min	
Type of contact light	Relay 230 V / 10 A µ-contact	
Incandescent/halogen lamp load	2300 W	
Compact and fluorescent lamps	1150 VA (cos φ = 0,5)	
Inrush current	max. 400 A / 200 µs	
LED lamp < 2 W	25 W	
LED lamp > 2 W	70 W	
Switching capacity presence	–	50 W / 50 VA
Ambient temperature	–15 °C ... +50 °C	
Type of protection	IP 54	

Detection range (Round)

Mounting height (A)	Head on to (r)	Diagonally (t)
2 m	5 m <sup>2</sup>   2,5 m	38 m <sup>2</sup>   7 m
2,5 m	7 m <sup>2</sup>   3 m	38 m <sup>2</sup>   7 m
3 m	13 m <sup>2</sup>   4 m	50 m <sup>2</sup>   8 m
3,5 m	13 m <sup>2</sup>   4 m	50 m <sup>2</sup>   8 m
4 m	13 m <sup>2</sup>   4 m	64 m <sup>2</sup>   9 m

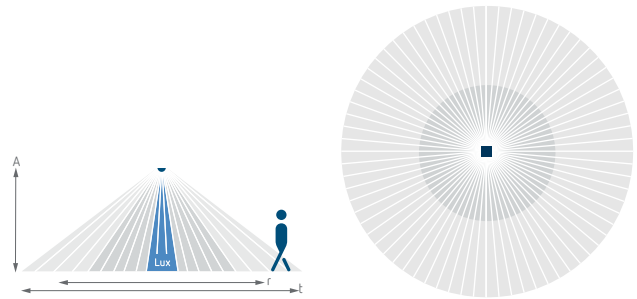

Accessories



SendoPro 868-A  
↳ Art.No.: 9070675  
Details page 339



theSenda P  
↳ Art.No.: 9070910  
Details page 341



theSenda S  
↳ Art.No.: 9070911  
Details page 341

Scale drawings

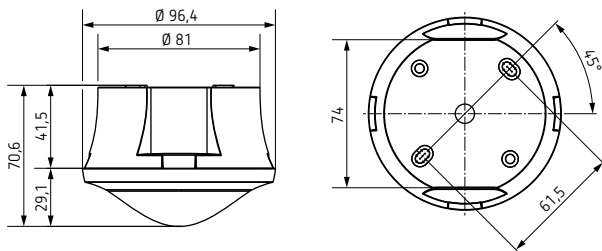

Connection diagrams

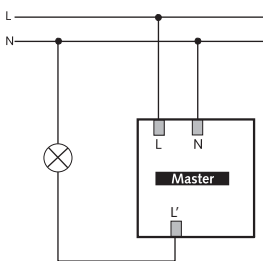

theMova S360-100 AP

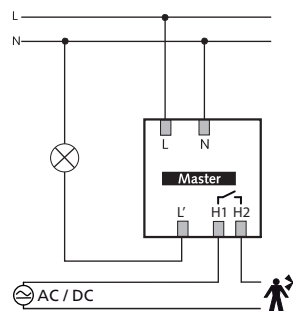

theMova S360-101 AP

# Presence and motion detectors

## Motion detectors



### Description

#### Common functions

- Passive infra-red motion detector for ceiling installation
- Circular detection area 360°, up to Ø 9 m (64 m²)
- Automatic motion and brightness-dependent control for lighting
- Mixed light measurement
- Channel A light: relay, 230 V
- Operation as fully automatic device
- Brightness switching value configurable, teach-in function
- Pulse function for staircase light time switch

- Time delay configurable
- Detection sensitivity configurable
- Test mode for checking function and detection area
- Ready for immediate use due to factory presetting (Brightness switching value 300 lux, Time delay 10 min)
- One of these optional remote controls is required for changing the values and attitudes:
  - Management remote control SendoPro
  - Installation remote control theSenda P
- Optional user remote control:
  - theSenda S

#### theMova S360-100 WH GST

- Motion detector (PIR), with pre-configured cable and Wieland GSTi18 connector, cable length 1,50 meter

#### theMova S360-100 WH WINSTA

- Motion detector (PIR), with pre-configured cable and WAGO WINSTA Midi connector, cable length 1,50 meter

### Product selection

Installation type	Channel	Operating voltage	Colour	Type	Article number
Ceiling installation	Light	230 V AC	White	theMova S360-100 WH GST	1030570
				theMova S360-100 WH WINSTA	1030575

### Technical data

	theMova S360-100 WH
Operating voltage	230 V AC
Frequency	50 Hz
Installation height	2 – 4 m
Power consumption	0,5 W
Setting range brightness	30 – 3000 lx
Light switch-off delay	10 s – 60 min
Type of contact light	Relay 230 V / 10 A µ-contact
Incandescent/halogen lamp load	2300 W
Compact and fluorescent lamps	1150 VA (cos φ = 0,5)
Inrush current	max. 400 A / 200 µs

	theMova S360-100 WH
LED lamp < 2 W	25 W
LED lamp 2–8 W	70 W
LED lamp > 8 W	80 W
Ambient temperature	-15 °C ... +50 °C
Type of protection	IP 54 (when fitted)

### Detection range (Round)

Mounting height (A)	Head on to (r)	Diagonally (t)
2 m	5 m <sup>2</sup>   2,5 m	38 m <sup>2</sup>   7 m
2,5 m	7 m <sup>2</sup>   3 m	38 m <sup>2</sup>   7 m
3 m	13 m <sup>2</sup>   4 m	50 m <sup>2</sup>   8 m
3,5 m	13 m <sup>2</sup>   4 m	50 m <sup>2</sup>   8 m
4 m	13 m <sup>2</sup>   4 m	64 m <sup>2</sup>   9 m

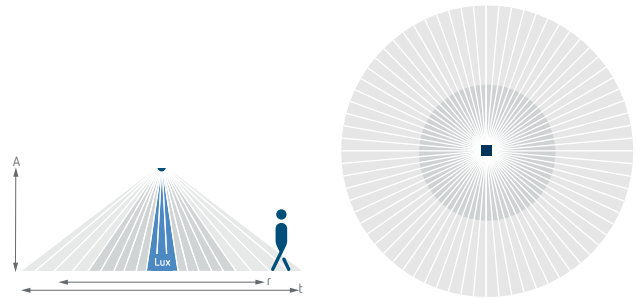

### Accessories



SendoPro 868-A  
↳ Art.No.: 9070675  
Details page 339



theSenda P  
↳ Art.No.: 9070910  
Details page 341



theSenda S  
↳ Art.No.: 9070911  
Details page 341

### Scale drawings

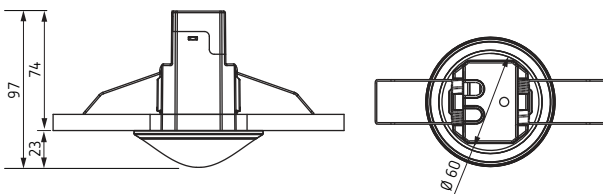

### Connection diagrams

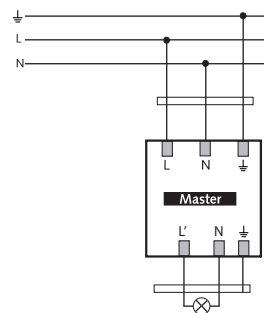

# Presence and motion detectors

## Motion detectors



### Description

- Passive infra-red motion detector for ceiling installation
- Circular detection area 360°, up to Ø 24 m (452 m<sup>2</sup>)
- Restriction of detection area with cover clips
- Automatic motion and brightness-dependent control for lighting
- Mixed light measurement suitable for fluorescent lamps (FL/PL/ESL), halogen/incandescent lamps and LEDs
- Channel A light: relay, 230 V
- Operation as fully automatic device
- Brightness switching value configurable, teach-in function
- Pulse function for staircase light time switch
- Time delay configurable
- Detection sensitivity configurable
- Ready for immediate use due to factory presetting
- Test mode for checking function and detection area
- Ceiling installation in flush-mounted socket
- Ceiling installation possible with back box, IP44 (option)
- User remote control theSenda S (option)
- Management remote control SendoPro (option)
- Installation remote control theSenda P (option)

### Product selection

Installation type	Channel	Operating voltage	Colour	Type	Article number
Ceiling installation	Light	110–230 V AC	White	theMova P360-100 UP WH	1030600
			Grey	theMova P360-100 UP GR	1030601

8

### Technical data

	theMova P360-100 UP
Operating voltage	110–230 V AC
Frequency	50–60 Hz
Recommended installation height	2–3,5 m
Power consumption	0,15 W
Setting range brightness	30–3000 lx
Light switch-off delay	10 s–60 min
Type of contact light	Relay 230 V/10 A μ-contact
Incandescent/halogen lamp load	2300 W
Compact and fluorescent lamps	1150 VA (cos φ = 0,5)
Inrush current	max. 800 A/200 μs
LED lamp < 2 W	60 W
LED lamp > 2 W	180 W
Ambient temperature	–15 °C ... +50 °C
Type of protection	IP 54 (when fitted)

Detection range (Round)

Mounting height (A)	Head on to (r)	Diagonally (t)
2 m	28 m <sup>2</sup>   6 m	380 m <sup>2</sup>   22 m
2,5 m	38 m <sup>2</sup>   7 m	415 m <sup>2</sup>   23 m
3 m	50 m <sup>2</sup>   8 m	452 m <sup>2</sup>   24 m
3,5 m	50 m <sup>2</sup>   8 m	452 m <sup>2</sup>   24 m
6 m	50 m <sup>2</sup>   8 m	452 m <sup>2</sup>   24 m
10 m	50 m <sup>2</sup>   8 m	452 m <sup>2</sup>   24 m

With a mounting height of more than 3.5 m and increasing temperatures the sensitivity of the detector decreases. Extent and distance between the active and passive zones also increases and the detection areas of several detectors should overlap in the marginal zone.

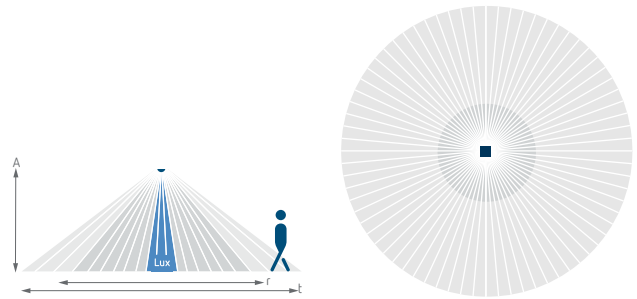

Accessories



Surface frame 110A WH  
↳ Art.No.: 9070912  
Details page 337



theSenda P  
↳ Art.No.: 9070910  
Details page 341



theSenda S  
↳ Art.No.: 9070911  
Details page 341

QuickSafe  
Details page 338

SendoPro 868-A  
Details page 339

Surface frame 110A GR  
Details page 337

Ceiling installation box 73A  
Details page 337

Masking clip  
Details page 337

Scale drawings

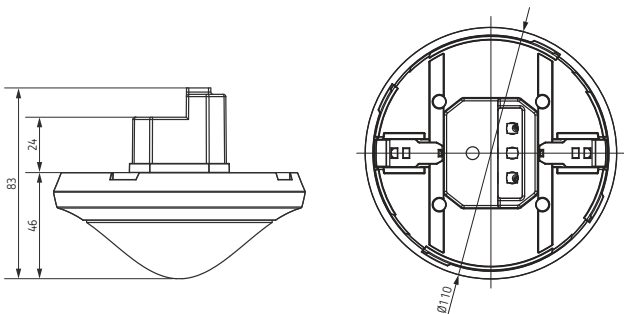

Connection diagrams

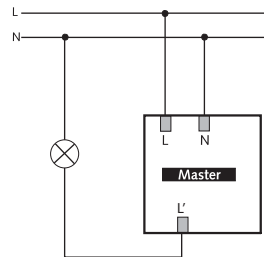

# Presence and motion detectors

## Motion detectors



theMova P360-100 WH GST

theMova P360-100 WH WINSTA

### Description

#### Common functions

- Passive infra-red motion detector for ceiling installation
- Circular detection area 360°, up to Ø 24 m (452 m<sup>2</sup>)
- Restriction of detection area with cover clips
- Automatic motion and brightness-dependent control for lighting
- Mixed light measurement suitable for fluorescent lamps (FL/PL/ESL), halogen/ incandescent lamps and LEDs
- Channel A light: relay, 230 V
- Operation as fully automatic device
- Brightness switching value configurable, teach-in function

- Pulse function for staircase light time switch
- Time delay configurable
- Detection sensitivity configurable
- Ready for immediate use due to factory presetting
- Test mode for checking function and detection area
- Ceiling installation in flush-mounted socket
- Ceiling installation possible with back box, IP 54 (option)
- User remote control theSenda S (option)
- Management remote control SendaPro (option)
- Installation remote control theSenda P (option)

#### theMova P360-100 WH GST

- Motion detector (PIR), with pre-configured cable and Wieland GSTi18 connector, cable length 1,50 meter

#### theMova P360-100 WH WINSTA

- Motion detector (PIR), with pre-configured cable and WAGO WINSTA Midi connector, cable length 1,50 meter

### Product selection

Installation type	Channel	Operating voltage	Colour	Type	Article number
Ceiling installation	Light	110–230 V AC	White	theMova P360-100 WH GST	1030610
				theMova P360-100 WH WINSTA	1030615

### Technical data

	theMova P360-100 WH GST	theMova P360-100 WH WINSTA
Operating voltage	110–230 V AC	
Frequency	50–60 Hz	
Installation height	2–10 m	
Power consumption	0,15 W	
Setting range brightness	30–3000 lx	
Light switch-off delay	10 s–60 min	
Type of contact light	Relay 230 V/ 10 A µ-contact	
Incandescent/halogen lamp load	2300 W	

	theMova P360-100 WH GST	theMova P360-100 WH WINSTA
Compact and fluorescent lamps	1150 VA ( $\cos \varphi = 0,5$ )	
Inrush current	max. 800 A / 200 $\mu$ s	
LED lamp < 2 W	60 W	
LED lamp 2–8 W	180 W	
LED lamp > 8 W	200 W	
Ambient temperature	–15 °C ... +50 °C	
Type of protection	IP 54 (when fitted)	

### Detection range (Round)

Mounting height (A)	Head on to (r)	Diagonally (t)
2 m	28 m <sup>2</sup>   6 m	380 m <sup>2</sup>   22 m
2,5 m	38 m <sup>2</sup>   7 m	415 m <sup>2</sup>   23 m
3 m	50 m <sup>2</sup>   8 m	452 m <sup>2</sup>   24 m
3,5 m	50 m <sup>2</sup>   8 m	452 m <sup>2</sup>   24 m
6 m	50 m <sup>2</sup>   8 m	452 m <sup>2</sup>   24 m
10 m	50 m <sup>2</sup>   8 m	452 m <sup>2</sup>   24 m

With a mounting height of more than 3.5 m and increasing temperatures the sensitivity of the detector decreases. Extent and distance between the active and passive zones also increases and the detection areas of several detectors should overlap in the marginal zone.

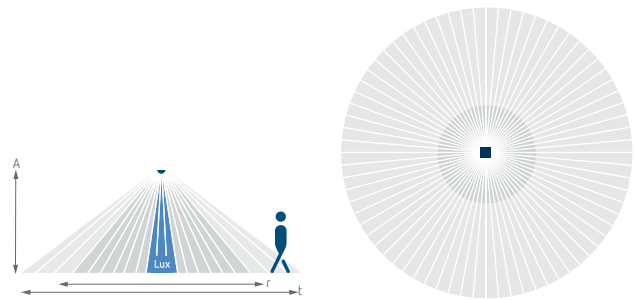

### Accessories



SendoPro 868-A  
↳ Art.No.: 9070675  
Details page 339



theSenda P  
↳ Art.No.: 9070910  
Details page 341



theSenda S  
↳ Art.No.: 9070911  
Details page 341

QuickSafe  
Details page 338

Masking clip  
Details page 337

### Scale drawings

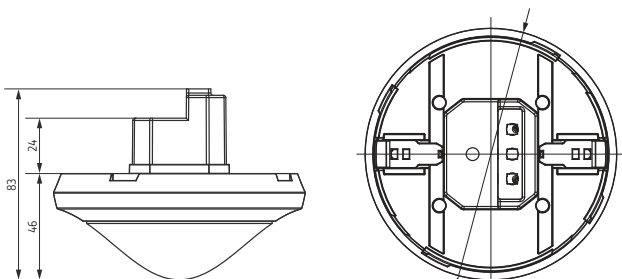

### Connection diagrams

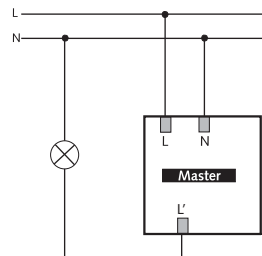

# Presence and motion detectors

## Motion detectors



### Description

#### Common functions

- Motion detector (PIR)
- Automatic lighting control based on presence and brightness
- Mixed light measurement suitable for the control of fluorescent, incandescent, halogen lamps and LED
- Zero-cross switching for relay-saving switching and high lamp loads
- Easy installation via two clamping brackets
- Large clamping area for quick installation
- Single-handed plug-in installation with captive screws
- Instant start-up possible via factory preset

- No unintentional adjustment due to covered up controls
- Adjustable brightness switching value and switch-off delay

#### LUXA 103-100 DE

- 1 channel
- System consists of power box and sensor with plugged connection cable

#### LUXA 103-101 DE

- 2 channels
- 2. Relay for HVAC control with adjustable switch-off delay, presence-dependent, potential-free

- HVAC control with programmable switch-off delay

- System consists of power box and sensor with plugged connection cable

#### LUXA 103-100 AP

- 1 channel

#### LUXA 103-101 AP

- 2 channels
- 2. Relay for HVAC control with adjustable switch-off delay, presence-dependent, potential-free
- HVAC control with programmable switch-off delay

### Product selection

Installation type	Channel	Operating voltage	Colour	Type	Article number
False ceilings	Light	230 V AC	White	LUXA 103-100 DE WH	1030012
	Light   Presence	230 V AC	White	LUXA 103-101 DE WH	1030013
Ceiling	Light	230 V AC	White	LUXA 103-100 AP WH	1030022
	Light   Presence	230 V AC	White	LUXA 103-101 AP WH	1030023

### Technical data

	LUXA 103-100 DE	LUXA 103-101 DE	LUXA 103-100 AP	LUXA 103-101 AP
Operating voltage	230 V AC			
Frequency	50–60 Hz			
Installation height	2–3 m			
Stand-by consumption	0,5 W			
Setting range brightness	10–2000 lx			
Light switch-off delay	5 s–30 min			
Switching capacity light	10 A (230 V AC, cos φ = 1)			
Incandescent lamp load	2000 W			
LED lamp < 2 W	35 W			
LED lamp > 2 W	400 W			
Switching capacity presence	–	5 A (250 V AC, cos φ = 1)	–	5 A (250 V AC, cos φ = 1)
Presence switch-off delay	–	10 s–60 min	–	10 s–60 min
Ambient temperature	0 °C ... +45 °C			
Type of protection	IP 44 (Sensor), IP 20 (power module)		IP 40	

Detection range (Round)

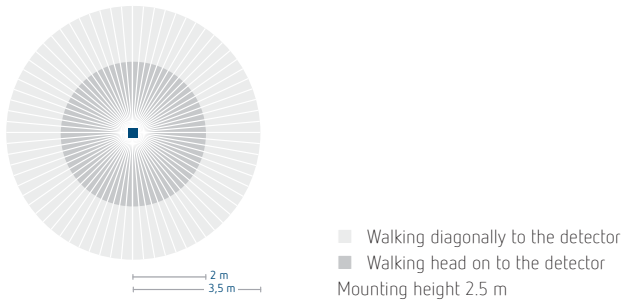

Dimensions

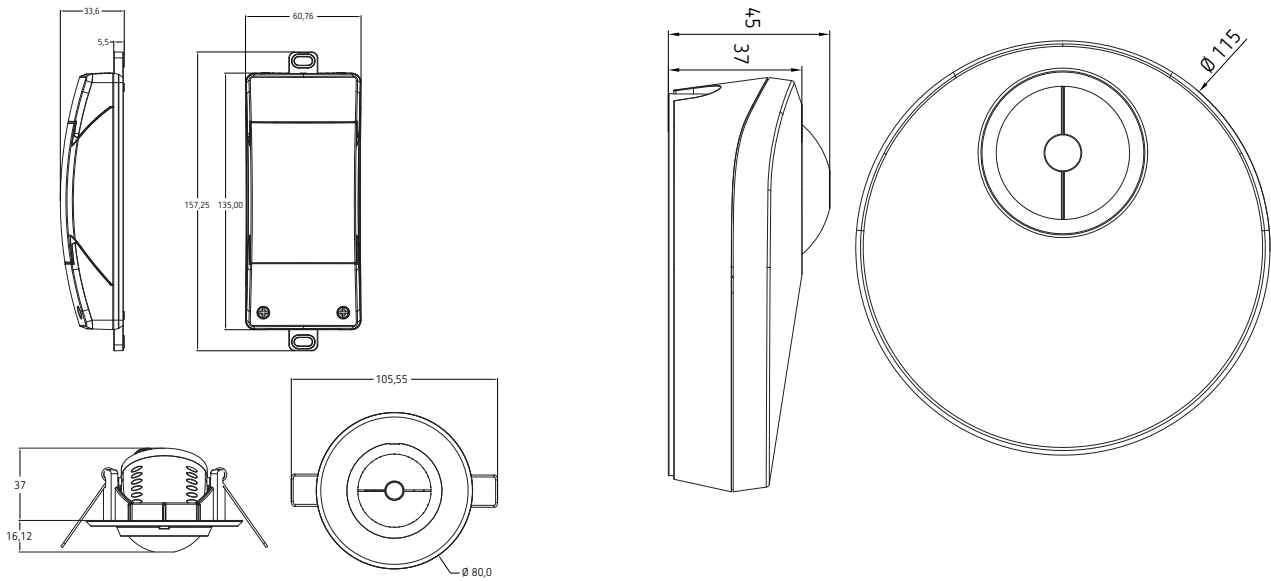

LUXA 103 DE

LUXA 103 AP

Connection diagrams

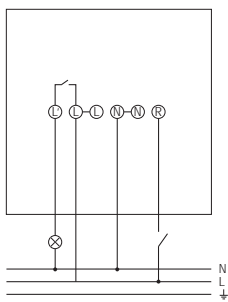

LUXA 103-100 DE

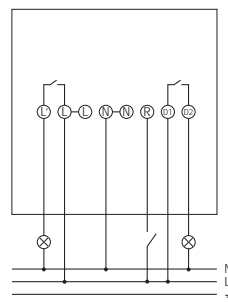

LUXA 103-101 DE

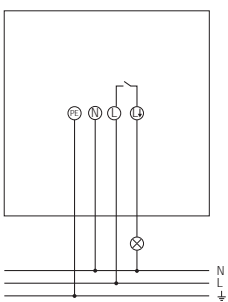

LUXA 103-100 AP

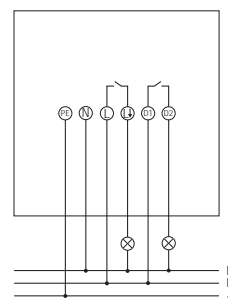

LUXA 103-101 AP

# Presence and motion detectors

## Motion detectors



### Description

#### Common functions

- Motion detector (PIR)
- Automatic lighting control based on presence and brightness
- Mixed light measurement suitable for the control of fluorescent, incandescent, halogen lamps and LED
- Zero-cross switching for relay-saving switching and high lamp loads
- Large clamping area for quick installation
- Single-handed plug-in installation with captive screws
- Instant start-up possible via factory preset
- No unintentional adjustment due to covered up controls
- Adjustable brightness switching value and switch-off delay

#### LUXA 103-100 C DE

- 1 channel

#### LUXA 103-101 C DE

- 2 channels
- 2. Relay for HVAC control with adjustable switch-off delay, presence-dependent, potential-free
- HVAC control with programmable switch-off delay

### Product selection

Installation type	Channel	Colour	Type	Article number
Ceiling installation	Light	White	LUXA 103-100 U WH	1030040
	Light   Presence	White	LUXA 103-100 UA WH	1030045

### Technical data

	LUXA 103-100 C DE	LUXA 103-101 C DE
Operating voltage	230 V AC	
Frequency	50–60 Hz	
Installation height	2–3 m	
Stand-by consumption	0,5 W	
Setting range brightness	10–2000 lx	
Light switch-off delay	5 s–30 min	
Switching capacity light	10 A (230 V AC, cos φ = 1)	
Incandescent lamp load	2000 W	
LED lamp < 2 W	35 W	
LED lamp > 2 W	400 W	
Switching capacity presence	–	5 A (250 V AC, cos φ = 1)
Presence switch-off delay	–	10 s–60 min
Ambient temperature	0 °C ... +45 °C	
Type of protection	IP 44	

Detection range (Round)

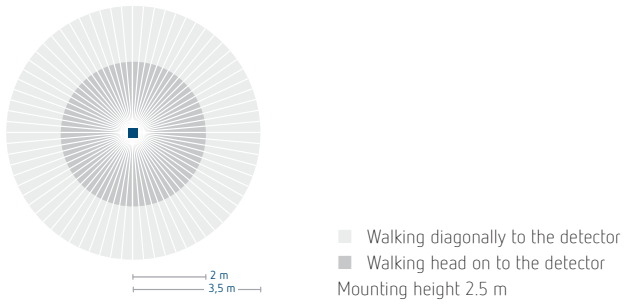

Dimensions

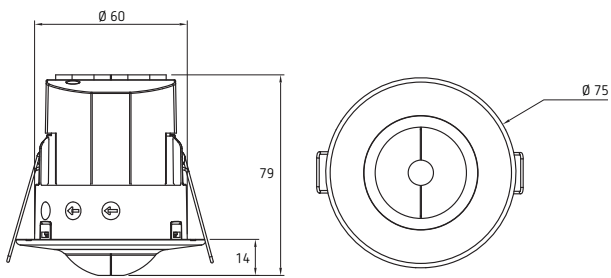

Connection diagrams

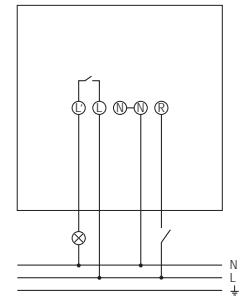

LUXA 103-100 C DE

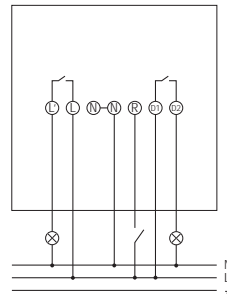

LUXA 103-101 C DE

# Presence and motion detectors

## Motion detectors



### Description

#### LUXA 103-100 U WH

- Motion detector (PIR)
- Automatic lighting control based on presence and brightness
- 1 channel
- Flexible installation options, ceiling installation using clamping brackets as well as flush-mounted or surface mounting using the optional surface frame
- Mixed light measurement suitable for the control of fluorescent, incandescent, halogen lamps and LED
- Zero-cross switching
- Detection area can be limited using three enclosed segments

- Instant start-up possible via factory preset
- No unintentional adjustment due to covered up controls
- Adjustable brightness switching value and switch-off delay
- Sensitivity can be reduced to limit detection area
- Pulse function
- Test function

#### LUXA 103-100 UA WH

- With acoustic function
- Activation by the PIR sensor and deactivation by the microphone (microphone can also be deactivated)

### Product selection

Installation type	Channel	With acoustic function	Colour	Type	Article number
Ceiling installation	Light	-	White	LUXA 103-100 U WH	1030040
		✓	White	LUXA 103-100 UA WH	1030045

### Technical data

	LUXA 103-100 UA WH
Operating voltage	230 V AC
Frequency	50–60 Hz
Stand-by consumption	0,5 W
Installation height	2–4 m
Detection angle	360°
Setting range brightness	10–2000 lx
Light switch-off delay	5s–30 min
Incandescent lamp load	2000 W
LED lamp < 2 W	35 W
LED lamp > 2 W	400 W
Ambient temperature	-20 °C ... +45 °C
Protection class	II
Type of protection	IP 40 (when fitted)

Detection range (Round)

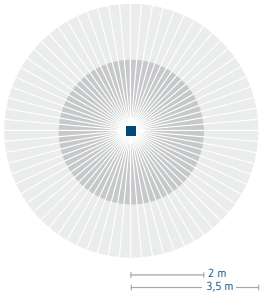

LUXA 103-100 U WH

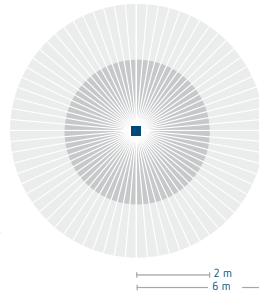

LUXA 103-100 UA WH

Dimensions

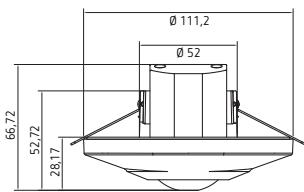

LUXA 103 U

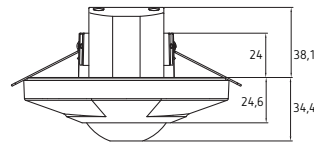
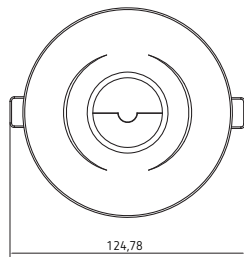

LUXA 103 UA

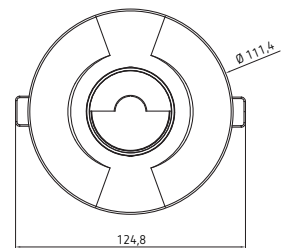

Connection diagrams

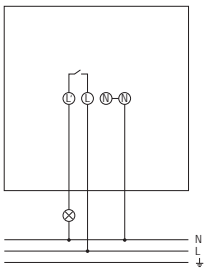

Accessories



Surface frame LUXA 103-100 U

↳ Art.No.: 9070986

Details page 341

# Presence and motion detectors

## Motion detectors



LUXA 103-200

### Description

- Motion detector (PIR)
- Automatic lighting control based on presence and brightness
- Wall installation
- Compatible with branded switches, replaces conventional light switches
- Area limit via lens attachment
- Manual AUTO/ON/OFF switching by simple adjustment of cover flap
- Teach-in of current brightness value
- Instant start-up possible via factory preset
- No unintentional adjustment due to covered up controls
- Adjustable brightness switching value and switch-off delay
- Sensitivity can be reduced to limit detection area
- Pulse function

### LUXA 103-200

- Mixed light measurement suitable for the control of fluorescent, incandescent and halogen lamps
- Expansion of detection area through integrated master/slave or master/master function when using up to 10 devices
- With acoustic advance shut-off warning 15 seconds before light switches off

### LUXA 103-200 T

- 2 wire connection, ideal for retrofitting
- Light switch output (triac, 230 V AC)
- Mixed light measurement suitable for incandescent and halogen lamps (no electronic ballast)
- Advance shut-off warning through dimming 15 seconds before light switches off

### Product selection

Installation type	Channel	Colour	Detection angle	Type	Article number
Flush-mounted wall installation	Light	White	200°, circular	LUXA 103-200	1030030
				LUXA 103-200 T	1030031

### Technical data

	LUXA 103-200	LUXA 103-200 T
Operating voltage	230 V AC	
Frequency	50 Hz	
Stand-by consumption	1 W	0,7 W
Setting range brightness	10 – 1000 lx Infinitely adjustable	
Switching capacity light	10 A (at 230 V AC, cos φ = 1), 3 AX (at 230 V AC, cos φ = 0.3)	2 A (at 230 V AC, cos φ = 1)
Detection angle	200°, circular	
Installation height	1,2 – 2 m	
Light switch-off delay	20 s – 30 min	
Incandescent lamp load	1000 W	400 W
Fluorescent lamp load (conventional) parallel-corrected	400 VA, 42 µF	–
Ambient temperature	0 °C ... +45 °C	
Protection class	II	
Type of protection	IP 40	

### Detection range (Semicircular)

Mounting height (A)	Head on to (r)	Diagonally (t)
1,2 – 2 m	3,5 m	8 m

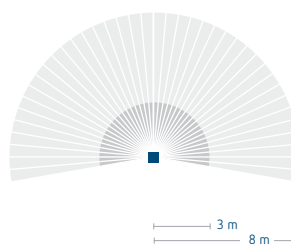

Accessories



Surface frame LUXA 103-200  
↳ Art.No.: 9070504  
Details page 341



RC filter  
↳ Art.No.: 9070523  
Details page 339

Scale drawings

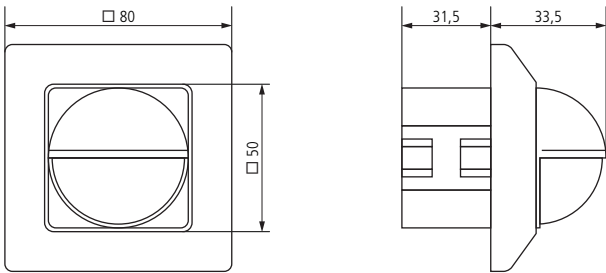

Connection diagrams

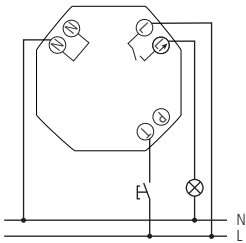

LUXA 103-200

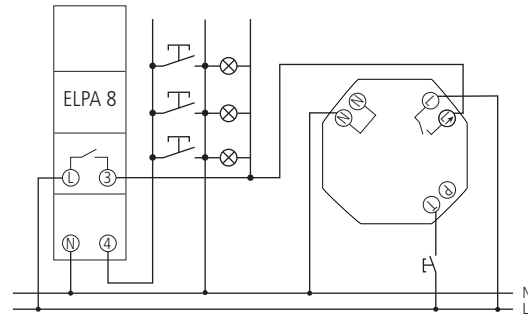

LUXA 103-200

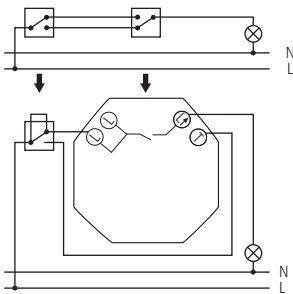

LUXA 103-200 T

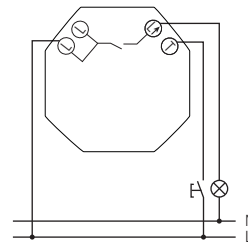









LUXA 103-200 T



## Space and time

There are daily processes that always follow a fixed schedule. It's good when everything is just so, Theben takes care of that, for example with its programmable clock thermostats, that create exactly the conditions expected – and that one is entitled to expect. This type of precision characterises Theben generally. It is apparent not just in our products. Above all, it characterises our thoughts and actions. As there is scarcely anything more important for us than precision.

Program	Type of connection	Operating voltage	Switching capacity at 250 V AC	Type of contact	Type	Page	
<b>Digital battery version</b>							
	Weekly program	2/3-way conductors	2 AA batteries	6 (1) A	Changeover contact	RAMSES 811 top2	204
						RAMSES 831 top2	204
	Radio controlled	2 AA batteries	16 (2) A	NO contact	RAMSES 813 top2 HF Set A	208	
					6 (1) A	Changeover contact	RAMSES 813 top2 HF Set 1
					RAMSES 833 top2 HF Set 1	210	
					RAMSES 833 top2 HF Set 2	210	
<b>Digital 230 V</b>							
	Weekly program	3-/4-conductors	230 V AC	6 (1) A	Changeover contact	RAMSES 812 top2	206
						RAMSES 832 top2	206
	Weekly program	DuoFix spring terminals	230 V AC	10 (2) A	Changeover contact	RAMSES 366/1 top2	212
<b>OpenTherm</b>							
	Weekly program	2-way conductor (BUS) room controller	230 V AC	2 x 2 (1) A Relay, 1 x 1 (1) A Relay	NO contact	RAMSES 816 top2 OT	214
						5 x 5 (1) A Relay, 2 x 1 (1) A Relay	NO contact
							
<b>Analogue battery version</b>							
	Daily program	2/3-way conductors	2 AA batteries	6 (1) A	Changeover contact	RAMSES 784 S	218
	Daily/weekly program	2/3-way conductors	2 AA batteries	6 (1) A	Changeover contact	RAMSES 784	220
<b>Analogue 230 V</b>							
	Daily program	3-/4-conductors	230 V AC	6 (1) A	Changeover contact	RAMSES 722 S	218
	Daily/weekly program	3-/4-conductors	230 V AC	6 (1) A	Changeover contact	RAMSES 722	220
						RAMSES 782	220
	Daily program	3-/4-conductors	230 V AC	6 (1) A	Changeover contact	RAMSES 721	220
	Daily/weekly program	3-/4-conductors	230 V AC	6 (1) A	Changeover contact	RAMSES 725	220

## Climate control

### Clock thermostats, Digital battery version

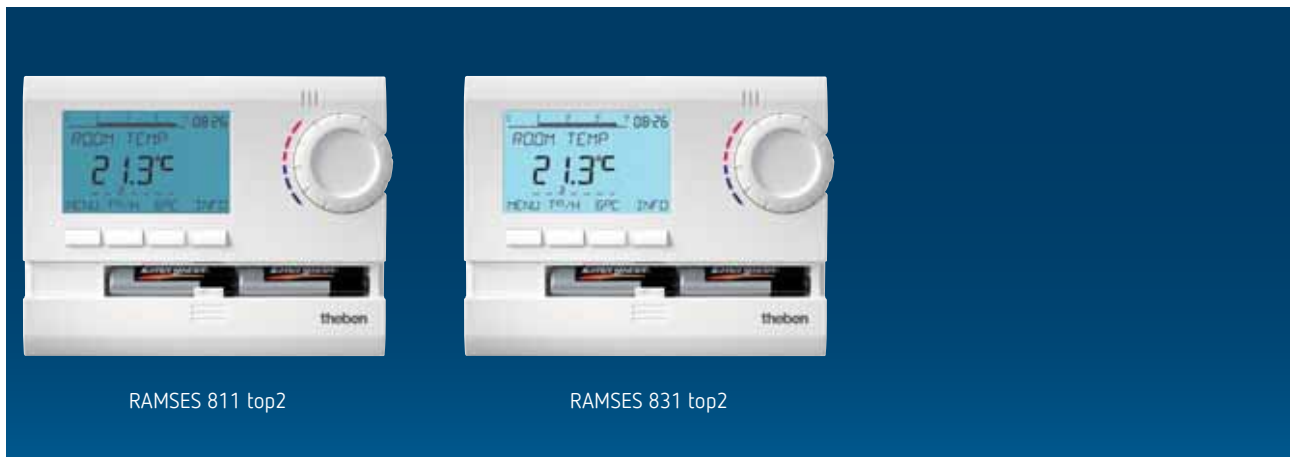

RAMSES 811 top2

RAMSES 831 top2

#### Description

##### Common functions

- Digital clock thermostat with a low profile design for time-dependent monitoring and control of room temperature
- Battery version
- Suitable for energy-saving room temperature control in houses, apartments, heating zones, offices, showrooms, factories, medical practices, holiday homes
- Temperature is set quickly via rotary switch
- INFO key for viewing important settings

- Quick start-up via 3 basic programs with individually changeable comfort and reduced temperature
- Party / ECO program
- Fully automatic summer/winter-time correction
- Holiday program with reduction phase or date-controlled heating phase for holiday homes
- Different control types can be individually set
- Optimum start option thanks to operating point and switching differential setting option

- 24 programmable time phases per program also enable reduction phases during the day
- Plug-in base for wall or flush-mounted socket installation

##### RAMSES 831 top2

- Backlit display through keystroke
- External input for connection of presence detectors, temperature sensors, floor sensors, window contacts or telephone remote switches
- Optimisation function for automatic correction of heating start up

9

#### Product selection

Type of connection	Program	Switching capacity at 250 V AC	Setting range temperature	Operating voltage	Type	Article number
2/3-way conductors	Weekly program	6 (1) A	+6 °C ... +30 °C	2 AA batteries	RAMSES 811 top2	8119132
					RAMSES 831 top2	8319132

### Technical data

	RAMSES 811 top2	RAMSES 831 top2
Operating voltage	2 AA batteries	
Type of contact	Changeover contact	
Switching capacity	6 A (at 250 V AC, $\cos \varphi = 1$ ), 1 A (at 250 V AC, $\cos \varphi = 0.6$ )	
Setting range temperature	+6 °C ... +30 °C	
Time basis	Quartz	
Program	Weekly program, Daily program, Holiday program, 3 basic programs	
Number of memory locations	42, max. 24 per program	
Control types	Pulse width modulation, Hysteresis controller	
Control period	5–30 min	
Control capture range	0,2–5 K	
Switching output	Potential-free	
Time accuracy at 25 °C	$\leq \pm 1$ s/day (quartz)	
Power reserve	Max. 10 mins without losing time	
Battery life	approx. 1 year, depending on switching frequency	
Type of protection	IP 20	
Protection class	II according to EN 60 730-1	

### Accessories



**Actuator ALPHA 5 230 V**  
↳ Art.No.: 9070441  
Details page 344



**Actuator ALPHA 5 24 V**  
↳ Art.No.: 9070442  
Details page 344



**Temperature sensor**  
for RAMSES 831 top2  
↳ Art.No.: 9070321  
Details page 343



**Temperature sensor RAMSES IP 65**  
for RAMSES 832 top2  
↳ Art.No.: 9070459  
Details page 343

9

### Scale drawings

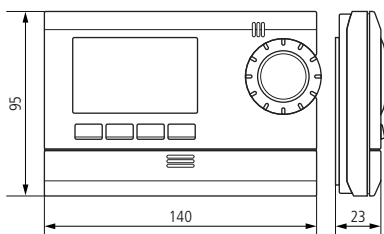

RAMSES 811 top2, RAMSES 831 top2

### Connection diagrams

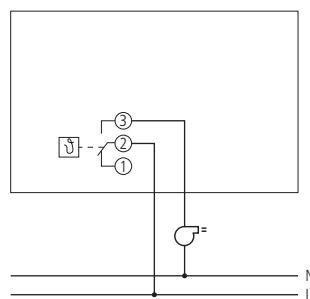

RAMSES 811 top2

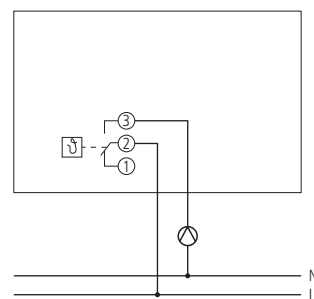

RAMSES 811 top2

# Climate control

## Clock thermostats, Digital 230 V

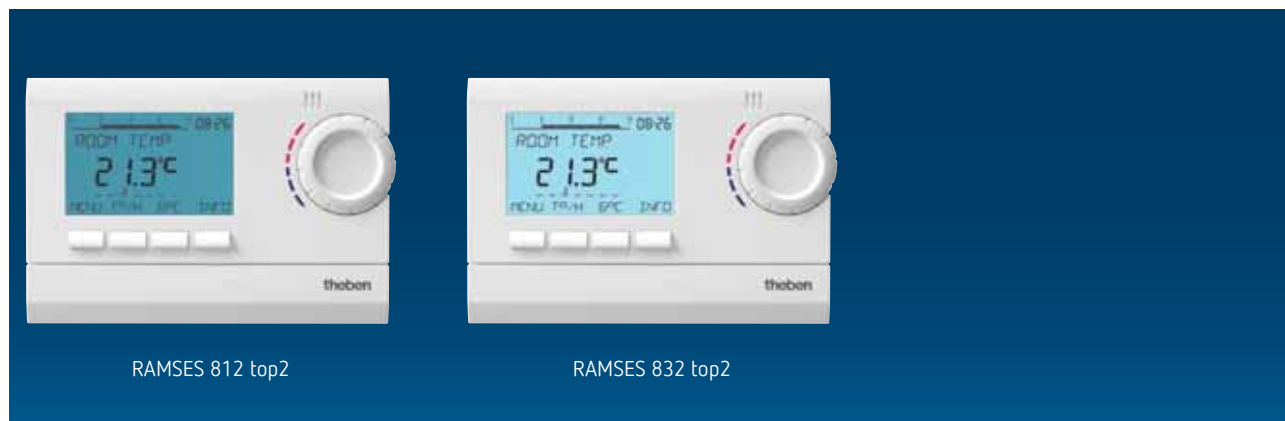

RAMSES 812 top2

RAMSES 832 top2

### Description

#### Common functions

- Digital clock thermostat with low profile design for time-dependent monitoring and control of room temperature
- Mains version
- Suitable for energy-saving room temperature control in houses, apartments, heating zones, offices, showrooms, factories, medical practices, holiday homes
- Temperature is set quickly via rotary switch
- INFO key for viewing important settings
- Quick start-up via 3 basic programs with individually changeable comfort and reduced temperature
- Party / ECO program
- Fully automatic summer/winter-time correction
- Different control types can be individually set
- Optimum start option thanks to operating point and switching differential setting option
- 24 programmable time phases per program also enable reduction phases during the day
- Plug-in base for wall or flush-mounted socket installation

#### RAMSES 832 top2

- Backlit display through keystroke
- External input for connection of presence detectors, temperature sensors, floor sensors, window contacts or telephone remote switches
- Optimisation function for automatic correction of heating start up

### Product selection

Type of connection	Program	Switching capacity at 250 V AC	Setting range temperature	Operating voltage	Type	Article number
3- /4-conductors	Weekly program	6 (1) A	+6 °C ... +30 °C	230 V AC	RAMSES 812 top2	8120132
					RAMSES 832 top2	8320132

### Technical data

	RAMSES 812 top2	RAMSES 832 top2
Operating voltage	230 V AC	
Frequency	50 Hz	
Type of contact	Changeover contact	
Switching capacity	6 A (at 250 V AC, cos φ = 1), 1 A (at 250 V AC, cos φ = 0.6)	
Setting range temperature	+6 °C ... +30 °C	
Time basis	Quartz	
Program	Weekly program, Daily program, Holiday program, 3 basic programs	
Number of memory locations	42, max. 24 per program	
Control types	Pulse width modulation, Hysteresis controller	
Control period	5–30 min	
Control capture range	0,2–5 K	
Switching output	Potential-free, not for SELV	
Time accuracy at 25 °C	≤ ± 1 s/day (quartz)	
Power reserve	5 hours	

	RAMSES 812 top2	RAMSES 832 top2
Stand-by consumption	0,4 W	
Type of protection	IP 20	
Protection class	II according to EN 60 730-1	

### Accessories



Actuator ALPHA 5 230 V  
↳ Art.No.: 9070441  
Details page 344



Actuator ALPHA 5 24 V  
↳ Art.No.: 9070442  
Details page 344



Temperature sensor  
for RAMSES 832 top2  
↳ Art.No.: 9070321  
Details page 343



Temperature sensor RAMSES  
IP 65  
for RAMSES 832 top2  
↳ Art.No.: 9070459  
Details page 343

### Scale drawings

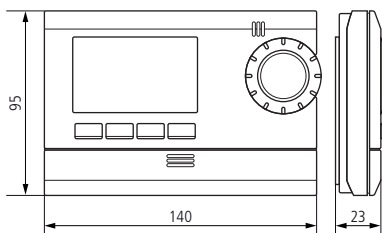

RAMSES 812 top2, RAMSES 832 top2

### Connection diagrams

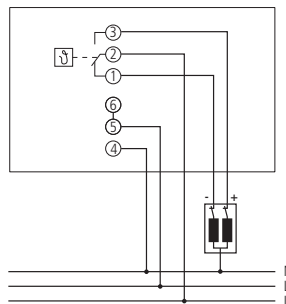

RAMSES 812 top2

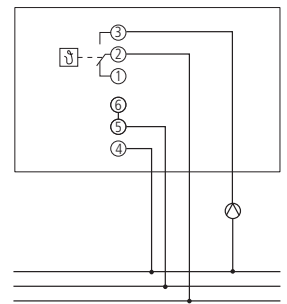

RAMSES 812 top2

### Connection diagrams

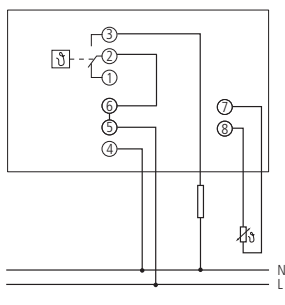

RAMSES 832 top2

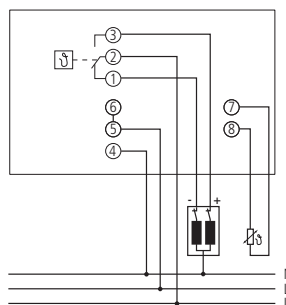

RAMSES 832 top2

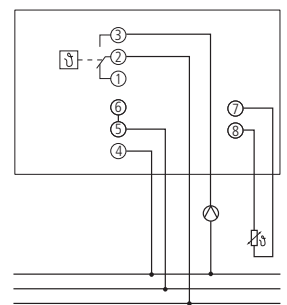

RAMSES 832 top2

# Climate control

## Clock thermostats, Digital battery version

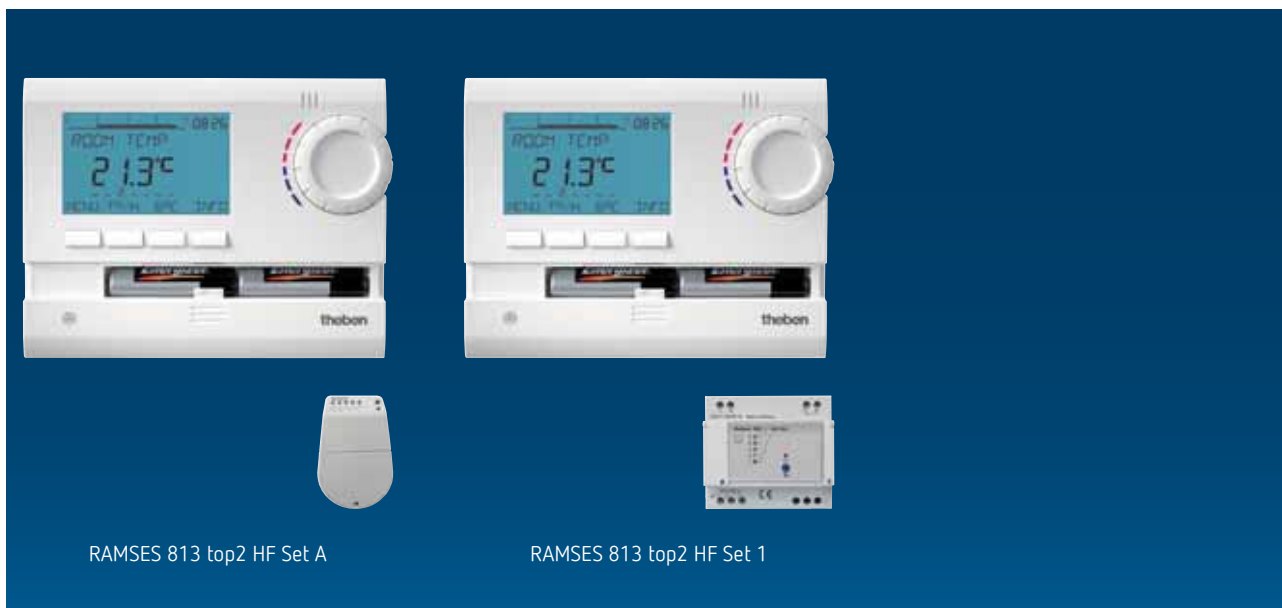

RAMSES 813 top2 HF Set A

RAMSES 813 top2 HF Set 1

### Description

#### Common functions

- Radio-controlled system for room temperature control
- The system consists of one digital clock thermostat and one receiver
- Suitable for energy-saving room temperature control in houses, apartments, heating zones, offices, showrooms, factories, medical practices, holiday homes
- Required temperature set via the rotary dial
- INFO key for viewing important settings
- Quick start-up via 3 basic programs with individually changeable comfort and reduced temperature
- Party / ECO program
- Automatic summer/winter time adjustment
- Different control types can be individually set

- Optimum start option thanks to operating point and switching differential setting option
- 24 programmable time phases per program also enable reduction phases during the day
- 2 comfort and 2 reduced temperatures can be allocated to each phase
- Including base for free choice of position
- An optionally available plug-in base is required for wall installation
- Holiday program with reduced temperature or date-controlled heating phase
- Optional pump protection function
- Optional feature to warn when boiler maintenance required

#### RAMSES 813 top2 HF Set A

- Consisting of a RAMSES 813 top2 HF and a REC 11 receiver with an NO contact 16(2) A/250 V AC for wall mounting

#### RAMSES 813 top2 HF Set 1

- Consisting of a RAMSES 813 top2 HF and a REC 1 receiver with a two-way switch 6(2) A/250 V AC

### Product selection

Type of connection	Program	Switching capacity at 250 V AC	Setting range temperature	Operating voltage	Type	Article number
Radio controlled	Weekly program	16 (2) A	+6 °C ... +30 °C	2 AA batteries	RAMSES 813 top2 HF Set A	8139503
	Weekly program	6 (1) A	+6 °C ... +30 °C	2 AA batteries	RAMSES 813 top2 HF Set 1	8139501

### Technical data

	RAMSES 813 top2 HF Set A	RAMSES 813 top2 HF Set 1
Operating voltage	2 AA batteries	
Type of contact	NO contact	Changeover contact
Switching capacity	16 A (at 250 V AC, $\cos \varphi = 1$ ), 2 A (at 250 V AC, $\cos \varphi = 0.6$ )	6 A (at 250 V AC, $\cos \varphi = 1$ ), 1 A (at 250 V AC, $\cos \varphi = 0.6$ )
Setting range temperature	+6 °C ... +30 °C	
Time basis	Quartz	
Program	Weekly program, Daily program, Holiday program, 3 basic programs	
Number of memory locations	42, max. 24 per program	
Control types	Pulse width modulation, Hysteresis controller	
Control period	5–30 min	
Control capture range	0,2–5 K	
Switching output	Potential-free, not for SELV	Potential-free
Time accuracy at 25 °C	$\pm 1$ s/day (quartz)	
Power reserve	Max. 10 mins without losing time	
Stand-by consumption	1,9 W	1,7 W
Battery life	approx. 1 year, depending on switching frequency	
Width	–	5 modules
Type of protection	IP 20	
Protection class	II according to EN 60 730-1	

### Accessories

#### Socket RAMSES

Details page 342

#### Actuator ALPHA 5 230 V

Details page 344

#### Actuator ALPHA 5 24 V

Details page 344

### Connection diagrams

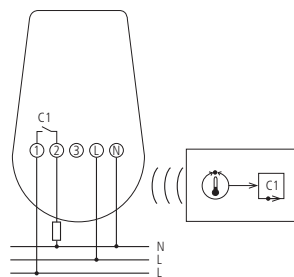

RAMSES 813 top2 HF Set A

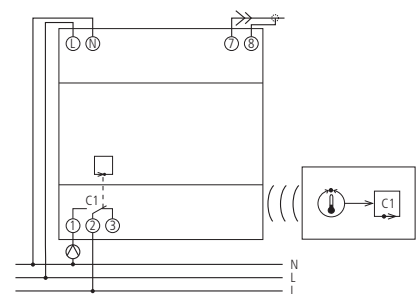

RAMSES 813 top2 HF Set 1

### Scale drawings

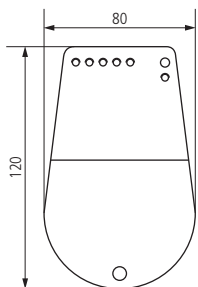

RAMSES 813 top2 HF Set A

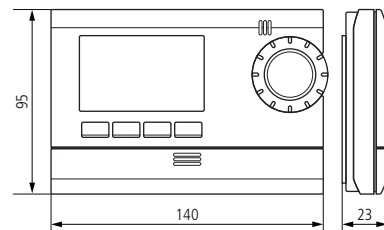

RAMSES 813 top2 HF

# Climate control

## Clock thermostats, Digital battery version



RAMSES 833 top2 HF Set 1

RAMSES 833 top2 HF Set 2

### Description

#### Common functions

- Radio-controlled system for room temperature control
- Suitable for energy-saving room temperature control in houses, apartments, heating zones, offices, showrooms, factories, medical practices, holiday homes
- The system consists of one or two digital clock thermostat and one receiver
- Required temperature set via the rotary dial
- INFO key for viewing important settings
- Quick start-up via 3 basic programs with individually changeable comfort and reduced temperature
- Party/ECO program
- Automatic summer/winter time adjustment
- Different control types can be individually set

- Optimum start option thanks to operating point and switching differential setting option
- 24 programmable time phases per program also enable reduction phases during the day
- Backlit display through keystroke
- External input for connection of presence detectors, temperature sensors, floor sensors, window contacts or telephone remote switches (can only be used in connection with optional plug-in base for wall mounting)
- Optimisation function for automatic correction of heating start up
- Holiday program with reduction phase or date-controlled heating phase for holiday homes

- Optional feature to warn when boiler maintenance required
- Optional pump protection function
- 3 comfort and 2 reduced temperatures can be allocated to each phase
- Including base for free choice of position
- An optionally available plug-in base is required for wall installation

#### RAMSES 833 top2 HF Set 1

- Consisting of a RAMSES 833 top2 HF and a REC 1 receiver with a two-way switch 6(2) A/250 VDC

#### RAMSES 833 top2 HF Set 2

- Consisting of two RAMSES 833 top2 HF and a 2 channel REC 2 receiver with a two-way switch 6(2) A/250 VDC per channel

### Product selection

Type of connection	Program	Switching capacity at 250 V AC	Setting range temperature	Operating voltage	Type	Article number
Radio controlled	Weekly program	6 (1) A	+6 °C ... +30 °C	2 AA batteries	RAMSES 833 top2 HF Set 1	8339501
	Weekly program	6 (1) A	+6 °C ... +30 °C	2 AA batteries	RAMSES 833 top2 HF Set 2	8339502

### Technical data

	RAMSES 833 top2 HF Set 1	RAMSES 833 top2 HF Set 2
Operating voltage	2 AA batteries	
Type of contact	Changeover contact	
Switching capacity	6 A (at 250 V AC, $\cos \varphi = 1$ ), 1 A (at 250 V AC, $\cos \varphi = 0.6$ )	
Setting range temperature	+6 °C ... +30 °C	
Time basis	Quartz	
Program	Weekly program, Daily program, Holiday program, 3 basic programs	
Number of memory locations	42, max. 24 per program	
Control types	Pulse width modulation, Hysteresis controller	
Control period	5–30 min	
Control capture range	0,2–5 K	
Switching output	Potential-free, not for SELV	
Time accuracy at 25 °C	$\leq \pm 1$ s/day (quartz)	
Power reserve	Max. 10 mins without losing time	
Stand-by consumption	1,7 W	2,2 W
Battery life	approx. 1 year, depending on switching frequency	
Width	5 modules	
Type of protection	IP 20	
Protection class	II according to EN 60 730-1	

### Accessories



**Actuator ALPHA 5 230 V**  
↳ Art.No.: 9070441  
Details page 344



**Temperature sensor**  
↳ Art.No.: 9070321  
Details page 343



**Temperature sensor RAMSES IP 65**  
for RAMSES 833 top2 HF Set 1  
↳ Art.No.: 9070459  
Details page 343

#### Socket RAMSES

Details page 342

#### Actuator ALPHA 5 24 V

Details page 344

9

### Scale drawings

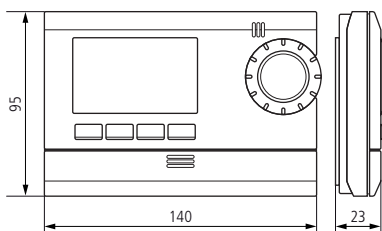

### Connection diagrams

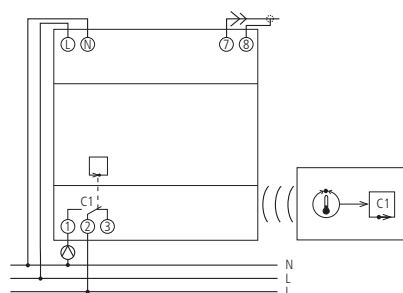

RAMSES 833 top2 HF Set 1

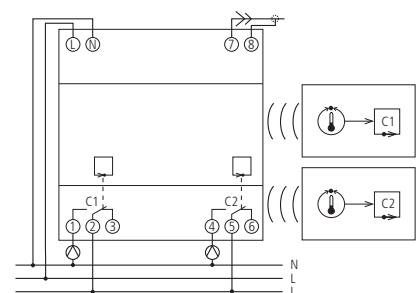

RAMSES 833 top2 HF Set 2

## Climate control

### Clock thermostats, Digital 230 V



RAMSES 366/1 top2

#### Description

- Digital clock thermostat with a low profile design for time-dependent monitoring and control of room temperature
- Zone control, 1 zone
- 1 external temperature sensor required
- Daily/weekly program can be set to the minute
- Date-controlled holiday program
- Programming displayed graphically by a bar arrangement in the LCD
- Fully automatic summer/winter-time correction
- Manual switching pre-selection and operation mode selector for: Automatic mode, comfort mode, reduction mode, frost protection mode
- PIN coding
- DuoFix spring terminals
- Text-oriented user guidance in display
- Interface for OBELISK top2 memory card (Copying of programs)

#### Product selection

Number of channels	Program	Switching capacity at 250 V AC	Setting range temperature	Operating voltage	Type	Article number
1	Weekly program	10 (2) A	+6 °C ... +30 °C	230 V AC	RAMSES 366/1 top2	3660100

#### Technical data

RAMSES 366/1 top2			
Operating voltage	230 V AC	Number of memory locations	42
Frequency	50–60 Hz	Time accuracy at 25 °C	≤ ± 0.25 s/day (quartz)
Type of contact	Changeover contact	Power reserve	10 years
Switching capacity	10 (2) A	Stand-by consumption	1,3 W
Setting range temperature	+6 °C ... +30 °C	Width	2 modules
Time basis	Quartz	Type of protection	IP 20
Program	Weekly program	Protection class	II

9

Accessories



Actuator ALPHA 5 230 V  
↳ Art.No.: 9070441  
Details page 344



Actuator ALPHA 5 24 V  
↳ Art.No.: 9070442  
Details page 344



Wall mounting kit 35 mm  
↳ Art.No.: 9070064  
Details page 334



Memory card OBELISK top2  
↳ Art.No.: 9070404  
Details page 335



Front panel kit  
↳ Art.No.: 9070001  
Details page 334



External temperature sensor 1  
↳ Art.No.: 9070191  
Details page 343



External temperature sensor 2  
↳ Art.No.: 9070192  
Details page 343

Connection diagrams

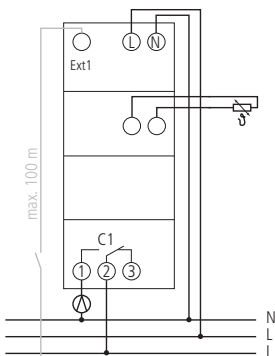

# Climate control

## Clock thermostats, OpenTherm



### Description

- Digital mixer control
- 3 different weekly programs
- 3 comfort and 2 reduced temperatures can be allocated to each zone
- INFO button for the most important data
- Party/ECO program
- Chimney sweeping function with push button OT box
- Minimum boiler temperature can be set
- 2-stage burner control option
- Holiday program with reduced temperature or date-controlled heating phase can be programmed e. g. for holiday homes
- USB interface for modem
- Automatic summer/winter time adjustment
- Control of feed temperature via motorcontrolled mixer
- 3-point controller with feed sensor
- Pump protection function
- Inputs: feed sensor heating circuit (contained in set), external sensor
- Elapsed-time counter for recording relay switching times e.g. burner operating time
- Adjustable reminder function for heater maintenance

### Product selection

Type of connection	Program	Switching capacity at 250 V AC	Setting range temperature	Operating voltage	Type	Article number
2-way conductor (BUS) room controller	Weekly program	2 x 2 (1) A, 1 x 1 (1) A	+6 °C ... +30 °C	230 V AC	RAMSES 816 top2 OT	8169132

### Technical data

RAMSES 816 top2 OT			
Operating voltage	230 V AC	Number of memory locations	42
Frequency	50 Hz	Switching hysteresis	2–20 K
Type of contact	NO contact	Mixer runtime	2–10 min
Switching capacity	2 x 2 (1) A Relay, 1 x 1 (1) A Relay	Power reserve	4 hours
Setting range temperature	+6 °C ... +30 °C	Stand-by consumption	~1,1 W
Flow temperature limit	+40 °C ... +90 °C	Type of protection	IP 20
Type of connection	2-way conductor (BUS) room controller	Protection class	II according to EN 60 730-1
Program	Weekly program		

9

Accessories



External temperature sensor  
↳ Art.No.: 9070463  
Details page 343



Temperature sensor RAMSES IP 65  
↳ Art.No.: 9070459  
Details page 343



Plunge sensor RAMSES  
↳ Art.No.: 9070379  
Details page 344

Scale drawings

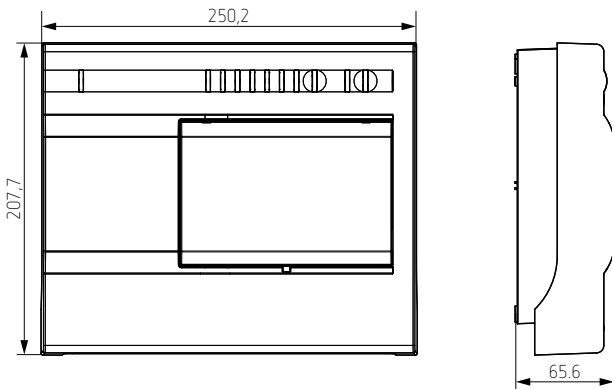

Connection diagrams

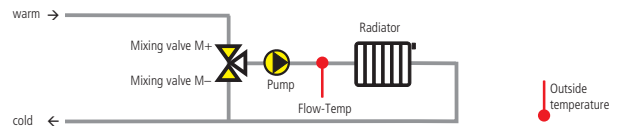
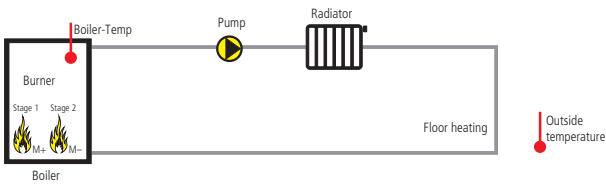

# Climate control

## Clock thermostats, OpenTherm



### Description

- Digital heating control for time-dependent monitoring and control of room temperature
- Open Therm heating controller for 2 or 3 point control, weather-dependent, service water and circulation control
- Automatic sensor recognition for weather- or room-dependent control; can be switched manually at any time
- 3 different weekly programs
- 3 comfort and 2 reduced temperatures can be allocated to each phase
- INFO button for the most important data
- Additional switching program for domestic hot water utilisation times
- Adjustable service water storage temperature, programmable legionella protection
- Party/ECO program
- Chimney sweeping function with push button OT box
- Minimum boiler temperature can be set
- 2 heating curves can be set for 2 heating circuits
- 2-stage burner control option
- Holiday program with reduced temperature or date-controlled heating phase can be programmed e. g. for holiday homes
- USB interface for modem
- Automatic summer/winter time adjustment
- Boiler/feed temperature (control circuit 1) controlled by switching the burner
- Control of feed temperature (control circuit 2) via pump control or motor-controlled mixer
- 3-point controller with feed sensor
- Time- and temperature-dependent control of hot water circulation pump.
- Pump protection function
- Inputs: External sensor (contained in set), feed sensor heating circuit (contained in set), contact or immersion sensor for domestic hot water, contact sensor for circulation
- Elapsed-time counter for recording relay switching times e.g. burner operating time
- Adjustable reminder function for heater maintenance

### Product selection

Type of connection	Program	Switching capacity at 250 V AC	Setting range temperature	Operating voltage	Type	Article number
2-way conductor (BUS) room controller	Weekly program	5 x 5 (1), 2 x 1 (1) A	+6 °C ... +30 °C	230 V AC	RAMSES 856 top2 OT	8569132

9

### Technical data

RAMSES 856 top2 OT			
Operating voltage	230 V AC	Number of memory locations	42, max. 24 per program
Frequency	50 Hz	Switching hysteresis	2–20 K
Type of contact	NO contact	Mixer runtime	2–10 min
Switching capacity	5 x 5 (1) A Relay, 2 x 1 (1) A Relay	Power reserve	4 hours
Setting range temperature	+6 °C ... +30 °C	Stand-by consumption	~1,1 W
Flow temperature limit	+40 °C ... +90 °C	Type of protection	IP 20
Type of connection	2-way conductor (BUS) room controller	Protection class	II according to EN 60 730-1
Program	Weekly program		

Accessories



Temperature sensor RAMSES IP 65  
↳ Art.No.: 9070459  
Details page 343



Flow temperature sensor RAMSES  
↳ Art.No.: 9070371  
Details page 343



OT-Box Standard  
↳ Art.No.: 9070712  
Details page 343



Plunge sensor RAMSES  
↳ Art.No.: 9070379  
Details page 344

Scale drawings

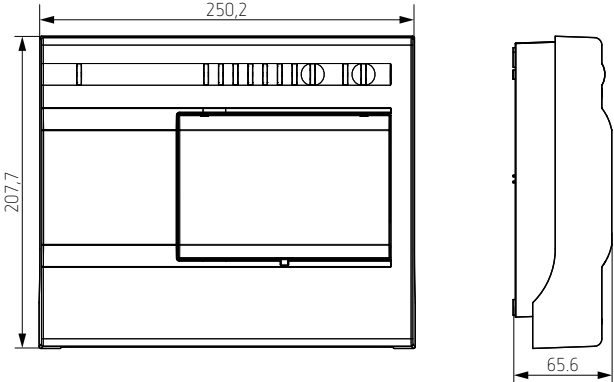

RAMSES 856 top2 OT

Connection diagrams

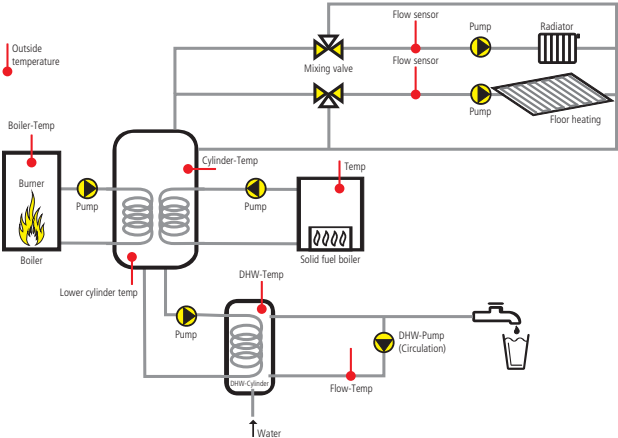

RAMSES 856 top2 OT (in combination with OT-Box 9070712)

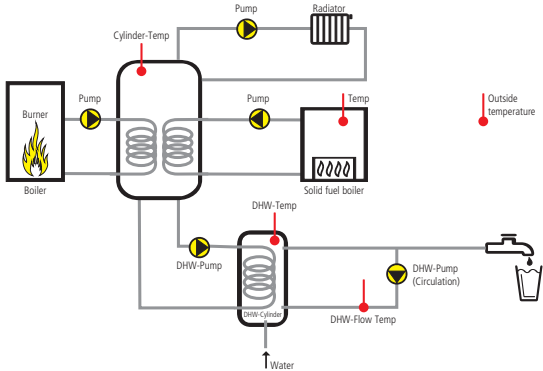

RAMSES 856 top2 OT

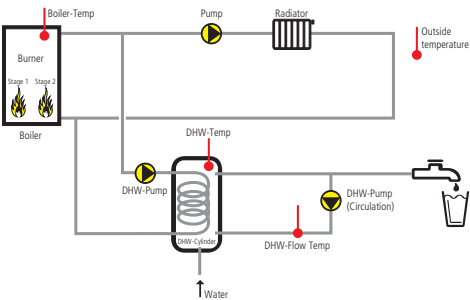

RAMSES 856 top2 OT

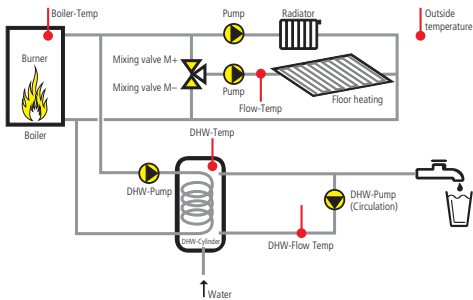

RAMSES 856 top2 OT

## Climate control

### Clock thermostats, Analogue battery version, Analogue 230 V



RAMSES 784 S

#### Description

##### Common functions

- Analogue clock thermostat with a low profile design for time-dependent monitoring and control of room temperature
- Segment program disc with daily program
- Normal and reduced temperature can be set separately
- Operating point and electronic recirculation are set from the front
- Party switch and program display

##### RAMSES 784 S

- Battery version
- Electronic temperature control
- Quartz mechanism
- Selector switch for operating mode: continuous reduced temperature, continuous normal temperature, automatic mode, frost and plant protection +6 °C
- Battery monitoring with battery replacement indicator via flashing LED
- Silting and pump protection function (option)

##### RAMSES 722 S

- Mains version
- Synchronous motor drive
- Electronic temperature control
- Selector switch for operating mode: continuous reduced temperature, continuous normal temperature, automatic mode, frost and plant protection +6 °C

#### Product selection

Power reserve	Type of connection	Program	Type of contact	Setting range temperature	Operating voltage	Type	Article number
-	2/3-way conductors	Daily program	Changeover contact	+10 °C ... +30 °C	2 AA batteries	RAMSES 784 S	7840801
-	3-/4-conductors	Daily program	Changeover contact	+10 °C ... +30 °C	230 V AC	RAMSES 722 S	7220801

# Climate control

## Clock thermostats, Analogue battery version, Analogue 230 V

### Technical data

	RAMSES 784 S	RAMSES 722 S
Operating voltage	2 AA batteries	230 V AC
Frequency	–	50 Hz
Type of contact	Changeover contact	
Program	Daily program	
Switching capacity	6 A (at 250 V AC, $\cos \varphi = 1$ ), 1 A (at 250 V AC, $\cos \varphi = 0.6$ )	
Switching differential	0,4–1,2 K	
Switching output	Potential-free	Potential-free, not for SELV
Setting range temperature	+10 °C ... +30 °C	
Shortest switching times	15 min	
Programmable every	15 min	
Time accuracy at 25 °C	$\leq \pm 1$ s/day (quartz)	Synchronised with mains
Stand-by consumption	–	1,3 W
Battery life	approx. 1 year, depending on switching frequency	–
Type of protection	IP 20	
Protection class	II according to EN 60 730-1	

### Accessories



Actuator ALPHA 5 230 V

↳ Art.No.: 9070441

Details page 344

Actuator ALPHA 5 24 V

Details page 344

Adapter RAMSES 72x/78x

Details page 342

### Scale drawings

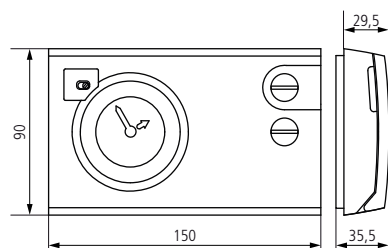

9

### Connection diagrams

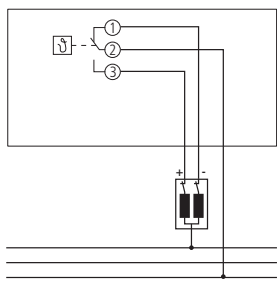

RAMSES 784 S

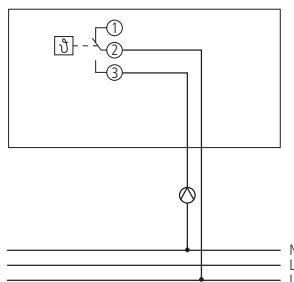

RAMSES 784 S

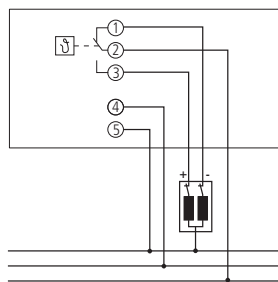

RAMSES 722 S

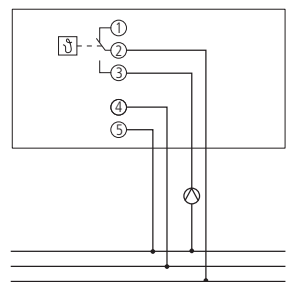

RAMSES 722 S

# Climate control

## Clock thermostats, Analogue battery version, Analogue 230 V



### Description

#### Common functions

- Analogue clock thermostat with a low profile design for time-dependent monitoring and control of room temperature
- Operating point and electronic recirculation are set from the front
- Party switch and program display

#### RAMSES 784

- Battery version
- Tappet program disc with daily or weekly program
- Electronic temperature control
- Normal and reduced temperature can be set separately
- Quartz mechanism
- Selector switch for operating mode: continuous reduced temperature, continuous normal temperature, automatic mode, frost and plant protection +6 °C
- Battery monitoring with battery replacement indicator via flashing LED
- Silting and pump protection function (option)

#### RAMSES 722

- Mains version

- Tappet program disc with daily or weekly program
- Synchronous motor drive
- Normal and reduced temperature can be set separately
- Electronic temperature control
- Selector switch for operating mode: continuous reduced temperature, continuous normal temperature, automatic mode, frost and plant protection +6 °C

#### RAMSES 782

- Mains version
- Tappet program disc with daily or weekly program
- Quartz mechanism, 3 day power reserve
- Normal and reduced temperature can be set separately
- Electronic temperature control
- Selector switch for operating mode: continuous reduced temperature, continuous normal temperature, automatic mode, frost and plant protection +6 °C

#### RAMSES 721

- Mains version
- Tappet program disc with daily program

- Synchronous motor drive
- Normal temperature can be set
- Reduced temperature approx. 5 K lower in relation to the set comfort temperature
- Without selector switch
- Electronic temperature control
- Selector switch for operating mode: continuous reduced temperature, continuous normal temperature, automatic mode, frost and plant protection +6 °C

#### RAMSES 725

- Mains version
- Tappet program disc with daily or weekly program
- Synchronous motor drive
- Reduced temperature can be set
- Central control of reduced temperature as per time program
- Electronic temperature control
- Selector switch for operating mode: continuous reduced temperature, continuous normal temperature, automatic mode, frost and plant protection +6 °C

### Product selection

Power reserve	Type of connection	Program	Type of contact	Setting range temperature	Operating voltage	Type	Article number
-	2/3-way conductors	Daily/weekly program	Changeover contact	+10 °C ... +30 °C	2 AA batteries	RAMSES 784	7840030
	3-/4-conductors	Daily/weekly program	Changeover contact	+10 °C ... +30 °C	230 V AC	RAMSES 722	7220030
3 days	3-/4-conductors	Daily/weekly program	Changeover contact	+10 °C ... +30 °C	230 V AC	RAMSES 782	7820030
-	3-/4-conductors	Daily program	Changeover contact	+10 °C ... +30 °C	230 V AC	RAMSES 721	7210030
		Daily/weekly program	Changeover contact	+10 °C ... +30 °C	230 V AC	RAMSES 725	7250030

# Climate control

## Clock thermostats, Analogue battery version, Analogue 230 V

### Technical data

	RAMSES 784	RAMSES 722	RAMSES 782	RAMSES 721	RAMSES 725
Operating voltage	2 AA batteries	230 V AC			
Frequency	–	50 Hz	50–60 Hz	50 Hz	
Type of contact	Changeover contact				
Program	Daily/weekly program			Daily program	Daily/weekly program
Switching capacity	6 A (at 250 V AC, $\cos \varphi = 1$ ), 1 A (at 250 V AC, $\cos \varphi = 0.6$ )				
Switching differential	0,4–1,2 K			1,5 K	
Switching output	Potential-free	Potential-free, not for SELV			
Setting range temperature	+10 °C ... +30 °C				
Shortest switching times	20 min, 120 min			20 min	20 min, 120 min
Programmable every	5 min, 30 min			5 min	5 min, 30 min
Time accuracy at 25 °C	$\leq \pm 1$ s/day (quartz)	Synchronised with mains	$\leq \pm 1$ s/day (quartz)	Synchronised with mains	
Power reserve	–	3 days		–	
Stand-by consumption	–	~1,3 W	1,1 W	1,3 W	1,4 W
Battery life	approx. 1 year, depending on switching frequency	–			
Type of protection	IP 20				
Protection class	II according to EN 60 730-1				

### Accessories



**Actuator ALPHA 5 230 V**  
↳ Art.No.: 9070441  
Details page 344

**Actuator ALPHA 5 24 V**  
Details page 344

**Adapter RAMSES 72x/78x**  
Details page 342

### Scale drawings

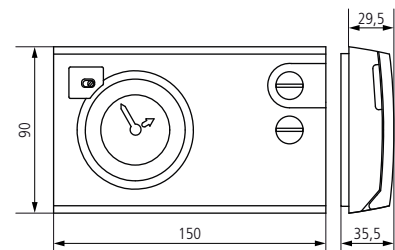

9

### Connection diagrams

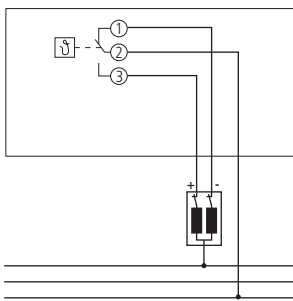

RAMSES 784

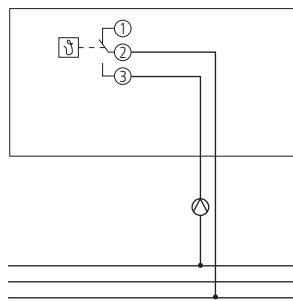

RAMSES 784

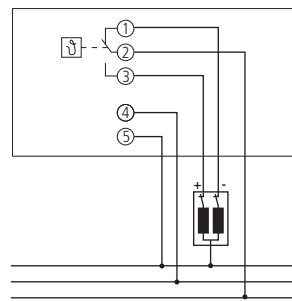

RAMSES 722, RAMSES 782,  
RAMSES 721, RAMSES 725

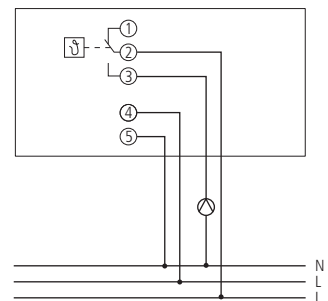







RAMSES 722, RAMSES 782,  
RAMSES 721, RAMSES 725



## The perfect work climate

Cause and effect: Whoever wants to act efficiently must create the best conditions for themselves and their employees. The right attitude is decisive. Theben provides it with products such as presence detectors, room thermostats or KNX systems for home and building automation, we help people live, work and achieve more in a relaxed way and in a pleasant atmosphere. As a company we offer exactly that to our employees: a reliable work environment. For us, it's a sign of our professionalism.

	Type of connection	Switching capacity at 230 V AC	Type of contact	Operating voltage	Installation type	Type	Page
<b>Mechanical</b>							
	2/3-way conductors	10 (4) A	NC contact	230–240 V AC	Surface-mounted	RAMSES 701	224
	3-/4-conductors	10 (4) A	NC contact	230–240 V AC	Surface-mounted	RAMSES 702	224
						RAMSES 703	224
						RAMSES 704	224
						RAMSES 705	224
4/5-way conductor	10 (4) A	NC contact	230–240 V AC	Surface-mounted	RAMSES 706	224	
					RAMSES 707	224	
	3-/4-conductors	Heating: 10 (4) A Cooling: 5 (2) A	Changeover contact	230–240 V AC	Surface-mounted	RAMSES 708	224
	4/5-way conductor	Heating: 10 (4) A Cooling: 5 (2) A	Changeover contact	230–240 V AC	Surface-mounted	RAMSES 709	224
	2/3-way conductors	10 (4) A	NC contact	230–240 V AC	Flush-mounted	RAMSES 741	226
	4/5-way conductor	10 (4) A	NC contact	230–240 V AC	Flush-mounted	RAMSES 746	226
	3-/4-conductors	Heating: 10 (4) A Cooling: 5 (1) A	Changeover contact	230–240 V AC	Flush-mounted	RAMSES 748	226
	2/3-way conductors	10 (4) A	NC contact	230–240 V AC	Flush-mounted	RAMSES 741 RA	226
	4/5-way conductor	10 (4) A	NC contact	230–240 V AC	Flush-mounted	RAMSES 746 RA	226
	3-/4-conductors	Heating: 10 (4) A Cooling: 5 (1) A	Changeover contact	230–240 V AC	Flush-mounted	RAMSES 748 RA	226
<b>Electronic</b>							
	2/3-way conductors	8 A (at 230 V AC, cos φ = 1)	NC contact	230 V AC	Surface-mounted	RAMSES 714	228
	4/5-way conductor	16 A (at 230 V AC, cos φ = 1)	NC contact	230 V AC	Surface-mounted	RAMSES 714 A	228
	5-way conductor	16 (4) A	NO contact	230 V AC	Flush-mounted	RAMSES 751 RA	228

# Climate control

## Room thermostats, Mechanical



### Description

#### Common functions

- Room temperature controller with thermal feedback
- Suitable for all types of heating, e.g. gas, water, electric heating with central/individual room control
- Setting controller with mechanical setting limit or detection

#### RAMSES 702

- Integrated temperature reduction (approx. 4 K) possible via control with time switch

#### RAMSES 703

- Internal setting: Temperature cannot be set externally. Temperature is set inside the device at start-up

- Integrated temperature reduction (approx. 4 K) possible via control with time switch

#### RAMSES 704

- Switch for additional heating ON/OFF + indicator lamp

#### RAMSES 705

- Switch for heating ON/OFF

#### RAMSES 706

- Switch for heating ON/OFF + indicator lamp
- Integrated temperature reduction (approx. 4 K) possible via control with time switch

#### RAMSES 707

- Switch for heating ON/OFF

- Switch for additional heating ON/OFF + indicator lamp

#### RAMSES 708

- Also suitable for air conditioning equipment
- Heating/cooling changeover contact

#### RAMSES 709

- Also suitable for air conditioning equipment
- Heating/cooling changeover contact
- 3-way selector switch for: comfort mode, reduction mode, external reduction
- Indicator lamp
- External temperature reduction (approx. 4 K) possible via control with time switch

10

### Product selection

Type of connection	Type of contact	Switching capacity at 230 V AC	Setting range temperature	Operating voltage	Type	Article number
2/3-way conductors	NC contact	10 (4) A	+5 °C ... +30 °C	230–240 V AC	RAMSES 701	7010001
3-/4-conductors	NC contact	10 (4) A	+5 °C ... +30 °C	230–240 V AC	RAMSES 702	7020001
					RAMSES 703	7030001
					RAMSES 704	7040001
					RAMSES 705	7050001
4/5-way conductor	NC contact	10 (4) A	+5 °C ... +30 °C	230–240 V AC	RAMSES 706	7060001
					RAMSES 707	7070001
3-/4-conductors	Changeover contact	Heating: 10 (4) A Cooling: 5 (2) A	+5 °C ... +30 °C	230–240 V AC	RAMSES 708	7080001
4/5-way conductor	Changeover contact	Heating: 10 (4) A Cooling: 5 (2) A	+5 °C ... +30 °C	230–240 V AC	RAMSES 709	7090001

Technical data

	RAMSES 701–RAMSES 707	RAMSES 708–RAMSES 709
Operating voltage	230–240 V AC	
Frequency	50–60 Hz	
Type of contact	NC contact	Changeover contact
Switching capacity	10 A (at 230 V AC, $\cos \varphi = 1$ ), 4 A (at 230 V AC, $\cos \varphi = 0.6$ )	Heating: 10 A (at 230 V AC, $\cos \varphi = 1$ ), 4 A (at 230 V AC, $\cos \varphi = 0.6$ ) Cooling: 5 A (at 230 V AC, $\cos \varphi = 1$ ), 2 A (at 230 V AC, $\cos \varphi = 0.6$ )
Setting range temperature	+5 °C ... +30 °C	
Control accuracy	Approx. 1 K, thermal recirculation	
Test approval		
Colour	Pure white (similar to RAL 9010)	
Installation type	Surface-mounted	
Type of protection	IP 30	
Protection class	II according to EN 60 730-1	

Accessories



Actuator ALPHA 5 230 V  
↳ Art.No.: 9070441  
Details page 344



Adapter plate RAMSES 70x  
↳ Art.No.: 9070480  
Details page 342

Scale drawings

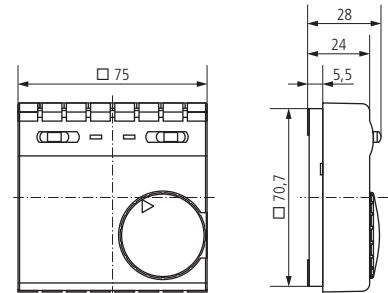

Connection diagrams

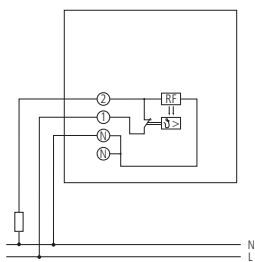

RAMSES 701

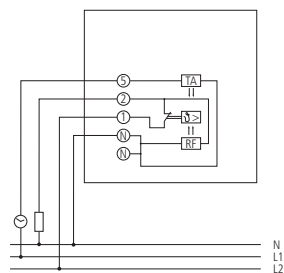

RAMSES 702, RAMSES 703

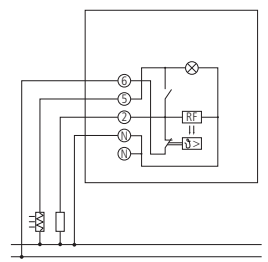

RAMSES 704

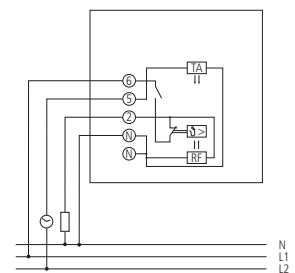

RAMSES 705

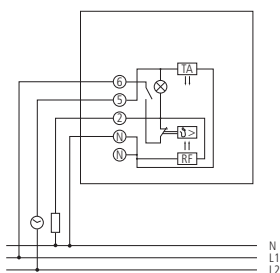

RAMSES 706

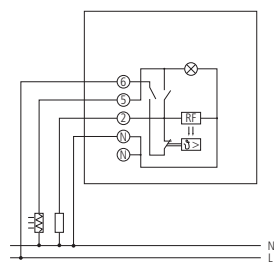

RAMSES 707

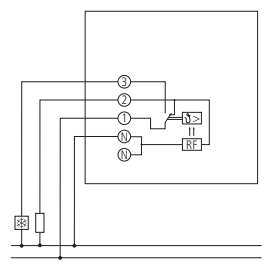

RAMSES 708

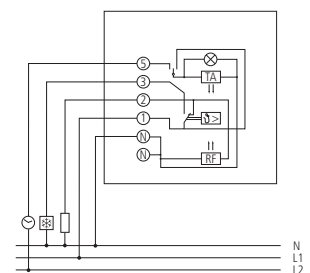

RAMSES 709

# Climate control

## Room thermostats, Mechanical



### Description

#### Common functions

- Room temperature controller with thermal feedback
- Central part fits nearly all frames using an adapter frame from the switch manufacturer
- Ideal controller for refurbished and new build properties

#### RAMSES 741

- Supplied as replacement device without frame, central part and setting button, incl. protective cap
- Frame, central part and setting button available as accessories

#### RAMSES 746

- Switch for heating ON/OFF + indicator lamp
- Supplied as replacement device without frame, central part and setting button, incl. protective cap
- Frame, central part and setting button available as accessories

#### RAMSES 748

- Heating/cooling two-way switch
- Supplied as replacement device without frame, central part and setting button, incl. protective cap

- Frame, central part and setting button available as accessories

#### RAMSES 741 RA

- With frame, central part and setting button

#### RAMSES 746 RA

- With frame, central part and setting button
- Switch for heating ON/OFF + indicator lamp

#### RAMSES 748 RA

- Heating/cooling two-way switch
- With frame, central part and setting button

### Product selection

Scope of delivery	Type of connection	Type of contact	Switching capacity at 230 V AC	Setting range temperature	Operating voltage	Type	Article number
Without cover	2/3-way conductors	NC contact	10 (4) A	+5 °C ... +30 °C	230–240 V AC	RAMSES 741	7410130
	4/5-way conductor	NC contact	10 (4) A	+5 °C ... +30 °C	230–240 V AC	RAMSES 746	7460130
	3-/4-conductors	Changeover contact	Heating: 10 (4) A Cooling: 5 (1) A	+5 °C ... +30 °C	230–240 V AC	RAMSES 748	7480130
With cover	2/3-way conductors	NC contact	10 (4) A	+5 °C ... +30 °C	230–240 V AC	RAMSES 741 RA	7410131
	4/5-way conductor	NC contact	10 (4) A	+5 °C ... +30 °C	230–240 V AC	RAMSES 746 RA	7460131
	3-/4-conductors	Changeover contact	Heating: 10 (4) A Cooling: 5 (1) A	+5 °C ... +30 °C	230–240 V AC	RAMSES 748 RA	7480131

## Technical data

	RAMSES 741	RAMSES 746	RAMSES 748	RAMSES 741 RA	RAMSES 746 RA	RAMSES 748 RA
Operating voltage	230–240 V AC					
Frequency	50–60 Hz					
Type of contact	NC contact		Changeover contact	NC contact		Changeover contact
Switching capacity	10 A (at 230 V AC, cos φ = 1), 4 A (at 230 V AC, cos φ = 0.6)		Heating: 10 A (at 230 V AC, cos φ = 1), 4 A (at 230 V AC, cos φ = 0.6) Cooling: 5 A (at 230 V AC, cos φ = 1), 1 A (at 230 V AC, cos φ = 0.6)	10 A (at 230 V AC, cos φ = 1), 4 A (at 230 V AC, cos φ = 0.6)		Heating: 10 A (at 230 V AC, cos φ = 1), 4 A (at 230 V AC, cos φ = 0.6) Cooling: 5 A (at 230 V AC, cos φ = 1), 1 A (at 230 V AC, cos φ = 0.6)
Setting range	+5 °C ... +30 °C					
Control accuracy	approx. 0.5 K, thermal recirculation					
Test approval						
Colour	–			Brilliant pure white (similar to RAL 9010)		
Installation type	Flush-mounted					
Type of protection	–			IP 30		
Protection class	II according to EN 60 730-1					

## Accessories



**Actuator ALPHA 5 230 V**  
↳ Art.No.: 9070441  
Details page 344

- Central part RAMSES 746**  
Details page 345
- Central part RAMSES 741/748**  
Details page 345
- Frame RAMSES 74x**  
Details page 344

## Scale drawings

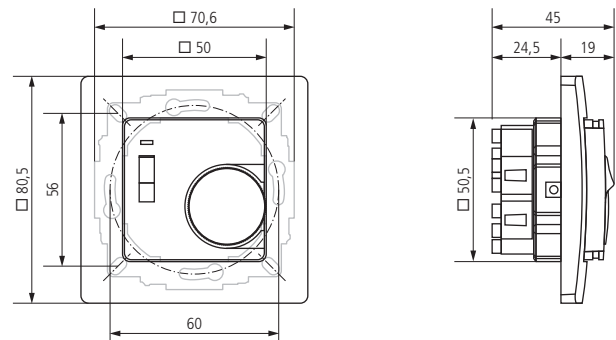

## Connection diagrams

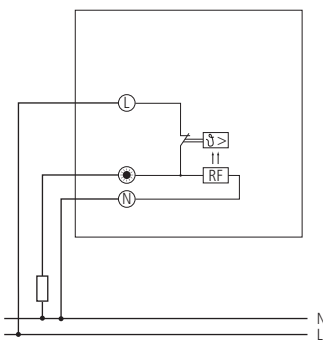

RAMSES 741, RAMSES 741 RA

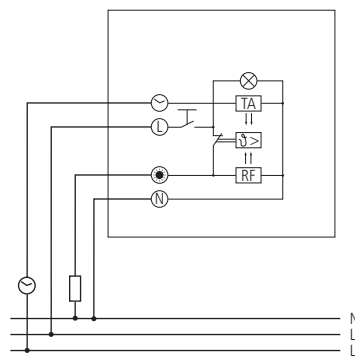

RAMSES 746, RAMSES 746 RA

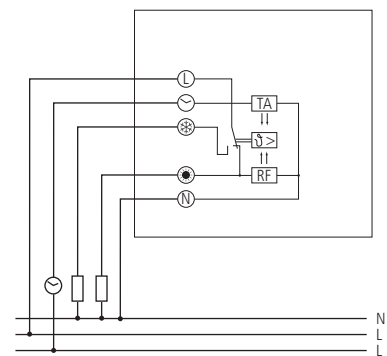

RAMSES 748, RAMSES 748 RA

# Climate control

## Room thermostats, Electronic



### Description

#### RAMSES 714

- Electronic room thermostats for all types of heating, e.g. gas, water, electric heating etc.
- Individual room control possible in combination with Theben actuators
- Heating status display via LED
- External temperature reduction (approx. 3.5 K) is possible via control with time switch. Temperature reduction can be cut to 2 K by opening a wire bridge

#### RAMSES 714 A

As RAMSES 714, but:

- External temperature sensor for underfloor heating (wet rooms or bathroom heating)
- Switchable for the connection of available NTC sensors (33 K $\Omega$ /25 °C)
- Switch for heating ON/OFF

#### RAMSES 751 RA

- Electronic room thermostat with remote temperature sensor for underfloor heating control

- Display of temperature reduction and heating ON
- 2-pole mains switch for heating ON/OFF
- Emergency mode for sensor malfunction at 30 % heating
- Central part fits nearly all frames using an adapter frame from the switch manufacturer

### Product selection

Type of connection	Type of contact	Switching capacity at 230 V AC	Setting range temperature	Installation type	Type	Article number
2/3-way conductors	NC contact	8 A (at 230 V AC, cos $\phi$ = 1)	+5 °C ... +30 °C	Surface-mounted	RAMSES 714	7140002
4/5-way conductor	NC contact	16 A (at 230 V AC, cos $\phi$ = 1)	+10 °C ... +60 °C	Surface-mounted	RAMSES 714 A	7140016
5-way conductor	NO contact	16 (4) A	+10 °C ... +50 °C	Flush-mounted	RAMSES 751 RA	7510131

### Technical data

	RAMSES 714	RAMSES 714 A	RAMSES 751 RA
Operating voltage	230 V AC		
Frequency	50 Hz		
Type of contact	NC contact		NO contact
Switching output	Not potential-free		Potential-free
Switching capacity	8 A (at 230 V AC, cos $\phi$ = 1)	16 A (at 230 V AC, cos $\phi$ = 1)	16 A (at 230 V AC, cos $\phi$ = 1), 4 A (at 230 V AC, cos $\phi$ = 0.6)
Setting range temperature	+5 °C ... +30 °C	+10 °C ... +60 °C	+10 °C ... +50 °C
Control accuracy	$\pm$ 0.25 K	$\pm$ 0.5 K	
Control behaviour	-		Proportional controller with PWM (continuous type)
Colour	Pure white (similar to RAL 9010)		
Installation type	Surface-mounted		Flush-mounted
Max. cable length	-	Length 4 m, $\varnothing$ 6 mm, (IP 54)	Length 4 m, $\varnothing$ 6 mm, extendable to 50 m
Ambient temperature	-		+0 °C ... +40 °C
Type of protection	IP 20		IP 30
Protection class	II according to EN 60 730-1		

Accessories



Actuator ALPHA 5 230 V  
↳ Art.No.: 9070441  
Details page 344



Adapter plate RAMSES 714  
for RAMSES 714, RAMSES 714 A  
↳ Art.No.: 9070212  
Details page 343

Scale drawings

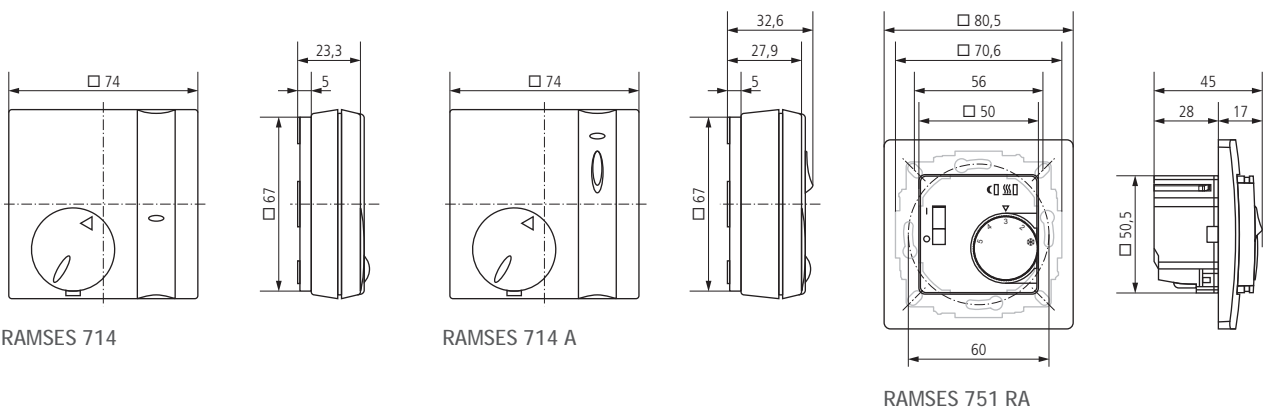

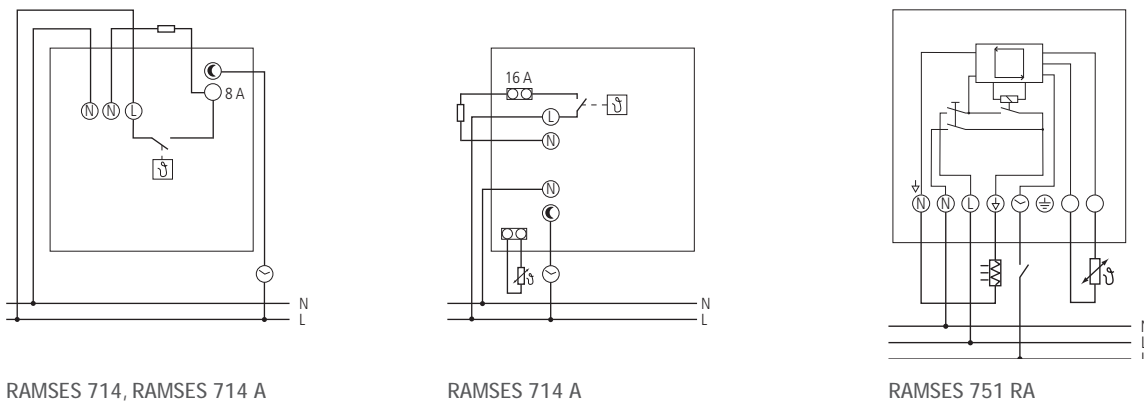

Connection diagrams





## The sense for what's fresh

Where a fresh wind blows, there is also room for new ideas. You need a feeling for what is needed – or a sensor. Theben offers many such sensors and each one of them helps inspire the mind. For example in public areas such as schools and universities or in offices. For many people the supply of fresh air is just a stimulus. However mostly it offers more: namely comfort.

Description	Type	Page
<b>CO<sub>2</sub> sensor</b>		
 CO <sub>2</sub> sensor for ventilation control and monitoring of air quality in the room with switch and analog outputs	AMUN 716 SR	232
<b>Hygrostat</b>		
 Hygrostat for wall installation for control of humidifiers or ventilation and dehumidifier systems	SOTHIS 715	233

# Climate control

## CO2 sensor



### Description

- CO<sub>2</sub> sensor
- Suitable for conference and meeting rooms, offices, schools/nurseries, passive and low-energy housing.
- For fan control
- Warning display for CO<sub>2</sub> concentration (lights)
- Power unit optionally available. Power unit is suitable for flush mounted installation
- Simple upgrade of uncontrolled ventilation systems possible
- 2 switch outputs CO<sub>2</sub> controlled for 2 stage control, with manual and automatic mode as well as display of switching status
- 3 x 0–10 V outputs for CO<sub>2</sub>, temperature and relative humidity

### Product selection

Measuring range	Data interface	Display	Operating voltage	Protection class	Type	Article number
0–5000 ppm	3 x 0-10 V, 2 x relay 5 A/250 V AC	LEDs	24 V AC/DC	II according to EN 60 730-1	AMUN 716 SR	7160110

### Technical data

AMUN 716 SR			
Operating voltage	24 V AC/DC SELV	Type of connection	Screw terminals
Outputs	3 x 0-10 V, 2 x relay 5 A/250 V AC	Display	6 LEDs
Measuring range CO <sub>2</sub>	0–5000 ppm	Installation type	Wall installation (also on flush-mounted socket possible)
Measuring range temperature	+5 °C ... +40 °C	Type of protection	IP 20
Measuring range humidity	30–80 % rH	Protection class	II according to EN 60 730-1
ON/OFF thresholds	700 ppm ±200 ppm, 1300 ppm ±200 ppm		

### Accessories



Power unit CO<sub>2</sub>-sensor  
↳ Art.No.: 9070494  
Details page 345

### Scale drawings

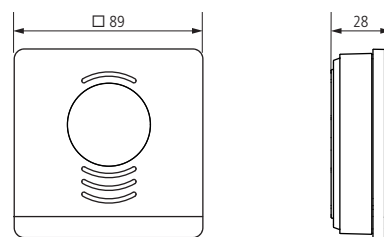

AMUN 716 SR



## Description

- Hygrostat for wall installation
- Measurement of relative humidity
- Suitable for control of humidifiers or ventilation and dehumidifier systems
- Use SELV when there is a risk of high humidity and the build up of condensation

## Product selection

Measuring range	Type of contact	Switching capacity humidifier	Switching capacity dehumidifying	Type	Article number
35–100 % rH	Changeover contact	2 A	5 A	SOTHIS 715	7150002

## Technical data

SOTHIS 715			
Switching capacity dehumidifying	5 A	Installation type	Wall installation
Switching capacity humidifier	2 A	Type of protection	IP 30
Suitable for SELV	Yes	Protection class	II according to EN 60 730-1
Colour	Pure white (similar to RAL 9010)		

## Accessories



Adapter plate RAMSES 714

↳ Art.No.: 9070212

Details page 343

## Scale drawings

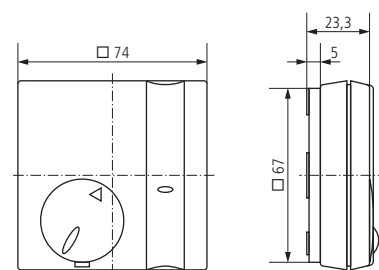

SOTHIS 715

## Connection diagrams

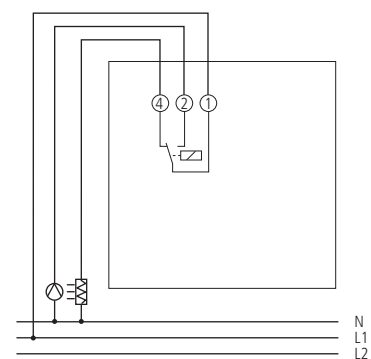













SOTHIS 715

## How innovation arises

Progress thrives on exchanging and from intelligently developing what's already proved itself or applying it to other spheres. Theben is an example of that. Over and over again, through changes in technology, we have pushed open the door to new areas and thus successfully completed the transformation from mechanical to electromechanical systems and digital technology to systems based on bus technology. Behind that lies the competence of our employees - and we do everything to promote that. Because that is the precondition for developing innovations.



Description	Type	Page
<b>Switching actuators</b>		
 Schaltaktoren	RMG 4 U KNX/RME 4 U KNX/ RM 4 U KNX/RMG 8 S KNX/RME 8 S KNX/RM 8 S KNX/ RM 16 S KNX/RMG 4 I KNX/RME 4 I KNX/RM 4 I KNX/RM 8 I KNX/RMG 8 T KNX/ RME 8 T KNX/RM 8 T KNX/RM 16 T KNXX	236
<b>Blinds actuators</b>		
 Blinds actuators	JMG 4 T KNX/JME 4 T KNX/JM 4 T KNX/JM 8 T KNX/JMG 4 T 24V KNX/ JME 4 T 24V KNX/JM 4 T 24V KNX/JM 8 T 24V KNX	244
<b>Dimming actuators</b>		
 Universal dimming actuators	DMG 2 T KNX/DME 2 T KNX/DMB 1 T KNX/DM 2 T KNX/DM 4 T KNX/DM 4-2 T KNX/ DM 8-2 T KNX	248
 Control units	SMG 2 S KNX/SME 2 S KNX	252
<b>Binary inputs</b>		
 Binary inputs	BMG 6 T KNX/BME 6 T KNX/BM 6 T KNX/BM 12 T KNX	254
 Binary inputs for flush-mounted sockets	TA 2 S KNX/TA 4 S KNX/TA 6 S KNX/TA 8 S KNX	256
<b>HVAC controller</b>		
 Multifunction display and room thermostats	VARIA 826 S KNX/RAMSES 718 P KNX/RAMSES 718 S KNX	257
 Heating actuators	HMG 6 T KNX/HME 6 T KNX/HM 6 T KNX/HM 12 T KNX/HMT 6 S KNX/HMT 12 S KNX	260
 Motor-driven actuators	CHEOPS control KNX/CHEOPS drive KNX	263
 CO <sub>2</sub> room air sensor	AMUN 716 S KNX	264
 Room thermostat Fan-Coil and Fan-Coil actuator	RAMSES 713 FC KNX/FCA 1 KNX /FCA 2 KNX	265
<b>Presence and motion detectors</b>		
 Presence detectors	PresenceLight 360 KNX/compact passage KNX/compact passimo KNX/thePrema KNX/ theRonda S KNX/theRonda P KNX/PlanoCentro KNX/PlanoSpot KNX/PlanoSpot S KNX/ PresenceLight 180 KNX	268
 Motion detectors	theLuxa P KNX/ SPHINX 331 S KNX/SPHINX 332 S KNX/theMova S360 KNX	284
<b>Weather station, brightness sensor</b>		
Weather stations KNX	Meteodata 140 S KNX/Meteodata 139 KNX	286
Brightness and temperature sensors	LUNA 134 KNX/LUNA 131 S KNX/LUNA 133 KNX	289
<b>Digital time switches/Time transmitter</b>		
8 channel time switch with yearly and astro program	TR 648 top2 RC KNX/TR 648 top2 RC-DCF KNX	292
Time transmitter	ZS 600 DCF KNX	294
<b>Gateways</b>		
KNX-OpenTherm-Gateway	KNX-OT-Box S	296
KNX-DALI-interface	DALI-Gateway KNX plus	295
<b>System devices</b>		
Supply voltage	PS 640 mA/320 mA/160 mA T KNX	297
Interface and line coupler	IP Interface KNX/IP Router KNX/Interface USB KNX/Line coupler S KNX	298
<b>Display units</b>		
KNX indoor clocks	OSIRIA KNX	300
<b>Visualisation</b>		
KNX-Visualisation	theServa S110	302

# Home and building control

## KNX, Switching actuators



### Description

#### Common functions

- Switching actuator
- LED switching status display for each channel
- Manual operation on device (even without bus connection)
- Switching functions: On/Off, pulse, On/Off delay, staircase light with warning
- Logical links: e.g. lock, AND, release, OR
- Adjustable characteristics: e.g. switching, delayed switching, pulse function
- Links, type of contact (NC contact/NO contact) and participation in central commands such as continuous On, continuous Off, central switching and save/call up scene

#### RMG 4 U KNX

- 4-way switching actuator MIX2
- Base module MIX2
- Can be upgraded to maximum of 12 channels
- Up to two extension modules MIX or MIX2 can be connected to one base module
- Device and KNX bus module can be swapped independently of each other
- Removable KNX bus module enables devices to be changed without reprogramming
- Manual set-up and use of switching actuators is possible without KNX bus module

#### RME 4 U KNX

- 4-way switching actuator MIX2
- Extension module MIX2
- For upgrading to maximum of 12 channels

#### RM 4 U KNX

- 4-way switching actuator

### Product selection

Function	Type	Article number
MIX2 Base module	RMG 4 U KNX	4930223
MIX2 Extension module	RME 4 U KNX	4930228
FIX1 Module	RM 4 U KNX	4940223

Technical data

	RMG 4 U KNX	RME 4 U KNX	RM 4 U KNX
Operating voltage KNX	Bus voltage, $\leq 4$ mA	–	Bus voltage, $\leq 4$ mA
Operating voltage	110–240 V AC	–	110–240 V AC
Frequency	50–60 Hz	–	50–60 Hz
Stand-by consumption	0,3 W	0,2 W	0,2 W
Width	4 modules		
Type of contact	NO contact, 16 A ( $\cos \varphi = 1$ ), 3 A ( $\cos \varphi = 0,6$ )		
Inrush current	max. 800 A / 200 $\mu$ s		
Resistive load	3680 W		
Glüh- / Halogenlampenlast	2000 W		
Incandescent lamp load	1200 W		
Energy saving lamps	300 W		
LED lamp < 2 W	55 W		
LED lamp 2–8 W	180 W		
LED lamp > 8 W	200 W		
Ambient temperature	–5 °C ... +45 °C		
Type of protection	IP 20		
Protection class	II		

Connection diagrams

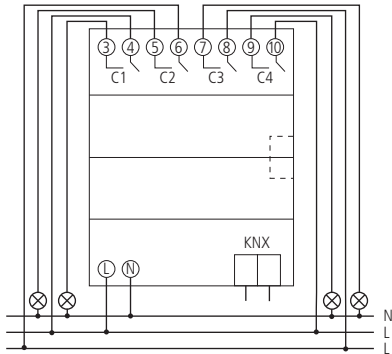

RMG 4 U KNX, RM 4 U KNX

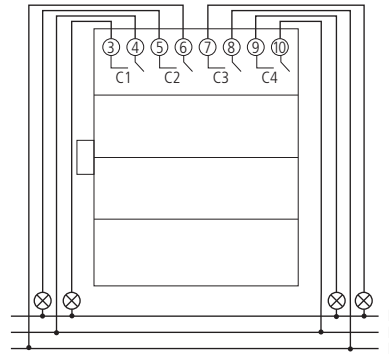

RME 4 U KNX

# Home and building control

## KNX, Switching actuators

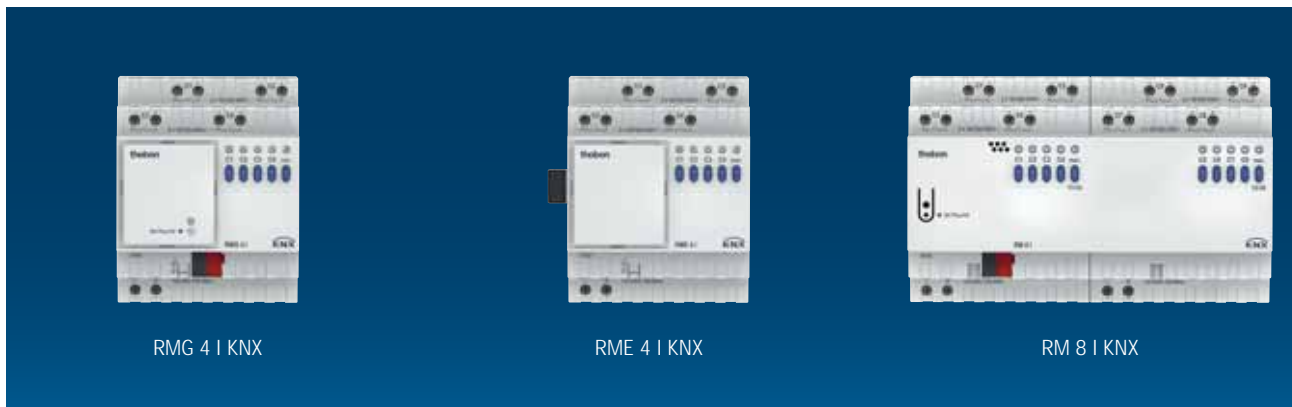

### Description

#### Common functions

- C load switching actuator
- With current recognition
- For higher lamp loads
- LED switching status display for each channel
- Manual operation on device (even without bus connection)
- Switching functions: On/Off, pulse, On/Off delay, staircase light with warning
- Logical links: e.g. lock, AND, release, OR
- Adjustable characteristics: e.g. switching, delayed switching, pulse function
- Links, type of contact (NC contact/NO contact) and participation in central commands such as continuous On, continuous Off, central switching and save/call up scene

#### RMG 4 I KNX

- 4-way C load switching actuator MIX2
- Base module MIX2
- Can be upgraded to maximum of 12 channels
- Up to two extension modules MIX or MIX2 can be connected to one base module
- Device and KNX bus module can be swapped independently of each other
- Removable KNX bus module enables devices to be changed without reprogramming
- Manual set-up and use of switching actuators is possible without KNX bus module

#### RME 4 I KNX

- 4-way C load switching actuator MIX2
- Extension module MIX2
- For upgrading to maximum of 12 channels

#### RM 8 I KNX

- 8-way C load switching actuator FIX1

#### RM 4 I KNX

- 4-way C load switching actuator FIX2

### Product selection

Function	Type	Article number
MIX2 Base module	RMG 4 I KNX	4930210
MIX2 Extension module	RME 4 I KNX	4930215
FIX1 module	RM 4 I KNX	4940210
FIX2 module	RM 8 I KNX	4940215

### Technical data

	RMG 4 I KNX	RME 4 I KNX	RM 8 I KNX	RM 4 I KNX
Operating voltage KNX	Bus voltage, $\leq 4$ mA	–	Bus voltage, $\leq 4$ mA	
Operating voltage	110–240 V AC			
Frequency	50–60 Hz			
Stand-by consumption	1,3 W	1,1 W	2,4 W	1,3 W
Width	4 modules		8 modules	4 modules
Type of contact	NO contact, 16 A ( $\cos \varphi = 1$ ), 10 A ( $\cos \varphi = 0,6$ )			
Inrush current	max. 1500 A / 200 $\mu$ s			
Resistive load	3680 W			
Incandescent lamp load	2600 W			
Fluorescent lamp load (electronic ballast)	1650 W			
Energy saving lamps	410 W			
LED lamp < 2 W	75 W			
LED lamp 2–8 W	250 W			
LED lamp > 8 W	300 W			
Ambient temperature	–5 °C ... +45 °C			
Type of protection	IP 20			
Protection class	II according to EN 60 669			

### Connection diagrams

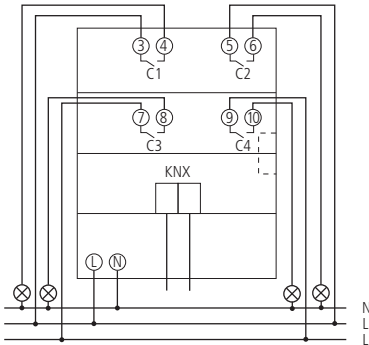

RMG 4 I KNX, RM 4 I KNX

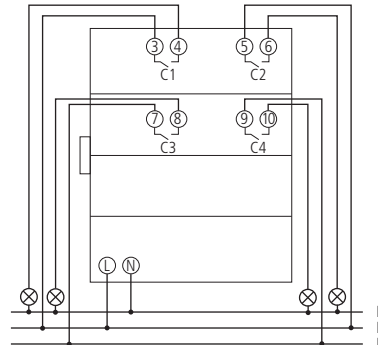

RME 4 I KNX

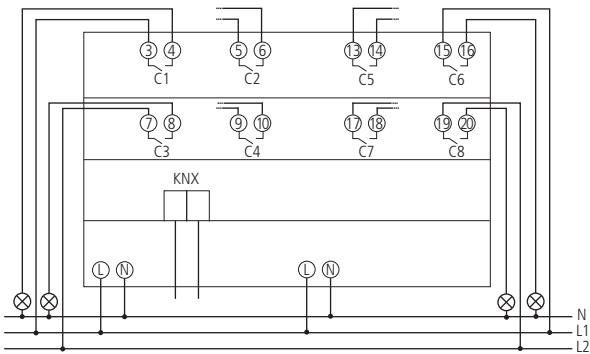

RM 8 I KNX

# Home and building control

## KNX, Switching actuators



### Description

#### Common functions

- Switching actuator
- LED switching status display for each channel
- Manual operation on device (even without bus connection)
- Switching functions: On/Off, pulse, On/Off delay, staircase light with warning
- Logical links: e.g. lock, AND, release, OR
- Adjustable characteristics: e.g. switching, delayed switching, pulse function
- Links, type of contact (NC contact/NO contact) and participation in central commands such as continuous On, continuous Off, central switching and save/call up scene

#### RMG 8 S KNX

- 8-way switching actuator MIX2
- Base module MIX2
- Can be upgraded to maximum of 24 channels
- Up to two extension modules MIX or MIX2 can be connected to one base module
- Device and KNX bus module can be swapped independently of each other
- Removable KNX bus module enables devices to be changed without reprogramming
- Manual set-up and use of switching actuators is possible without KNX bus module

#### RME 8 S KNX

- 8-way switching actuator MIX2
- Extension module MIX2
- For upgrading to maximum of 24 channels

#### RM 8 S KNX

- 8-way switching actuator FIX1

#### RM 16 S KNX

- 16-way switching actuator FIX2

### Product selection

Function	Type	Article number
MIX2 Base module	RMG 8 S KNX	4930220
MIX2 Extension module	RME 8 S KNX	4930225
FIX1 module	RM 8 S KNX	4940220
FIX2 module	RM 16 S KNX	4940225

### Technical data

	RMG 8 S KNX	RME 8 S KNX	RM 8 S KNX	RM 16 S KNX
Operating voltage KNX	Bus voltage, $\leq 4$ mA	-	Bus voltage, $\leq 4$ mA	
Operating voltage	110–240 V AC	-	110–240 V AC	
Frequency	50–60 Hz	-	50–60 Hz	
Stand-by consumption	0,3 W	0,2 W	0,3 W	
Width	4 modules			8 modules
Type of contact	NO contact, 16 A ( $\cos \varphi = 1$ ), 3 A ( $\cos \varphi = 0,6$ )			
Inrush current	max. 800 A / 200 $\mu$ s			
Resistive load	3680 W			
Glüh- / Halogenlampenlast	2000 W			
Incandescent lamp load	1200 W			
Energy saving lamps	300 W			
LED lamp < 2 W	55 W			
LED lamp 2–8 W	180 W			
LED lamp > 8 W	200 W			
Ambient temperature	-5 °C ... +45 °C			
Type of protection	IP 20			
Protection class	II			

### Connection diagrams

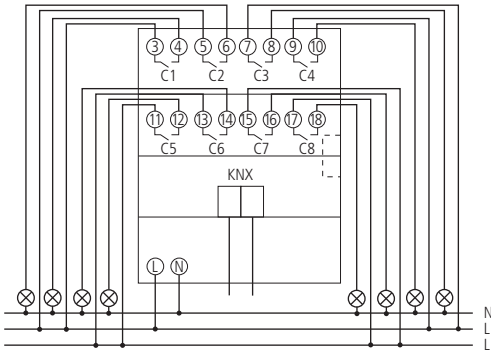

RMG 8 S KNX, RM 8 S KNX

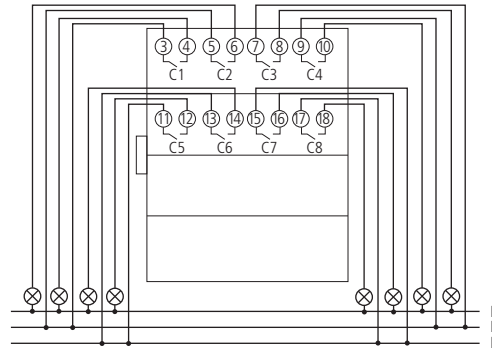

RME 8 S KNX

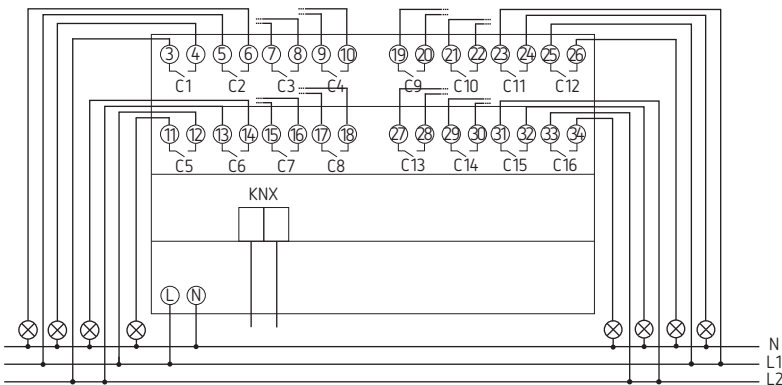

RM 16 S KNX

# Home and building control

## KNX, Switching actuators



### Description

#### Common functions

- Switching or blind actuator
- Flexible channel function selection as switching actuator or for controlling drives for blinds, shutters, sun and vision protection devices, skylights and ventilation flaps
- LED switching status display for each channel
- Manual operation on device (even without bus connection)
- Switching functions: On/Off, pulse, On/Off delay, staircase light with warning
- Logical links: e.g. lock, AND, release, OR
- Adjustable characteristics: e.g. switching, delayed switching, pulse function
- Links, type of contact (NC contact/NO contact) and participation in central commands such as continuous On, continuous Off, central switching and save/call up scene

#### RMG 8 T KNX

- 8-way switching or 4-way blind actuator MIX2
- Base module MIX2
- Can be upgraded to maximum of 24 channels
- Up to two extension modules MIX or MIX2 can be connected to one base module
- Device and KNX bus module can be swapped independently of each other
- Removable KNX bus module enables devices to be changed without reprogramming
- Manual set-up and use of actuator is possible without KNX bus module

#### RME 8 T KNX

- 8-way switching or 4-way blind actuator MIX2
- Extension module MIX2
- For upgrading to maximum of 24 channels

#### RM 8 T KNX

- 8-way switching or 4-way blind actuator FIX1

#### RM 16 T KNX

- 16-way switching or 8-way blind actuator FIX2

### Product selection

Function	Type	Article number
MIX2 Base module	RMG 8 T KNX	4930200
MIX2 Extension module	RME 8 T KNX	4930205
FIX1 module	RM 8 T KNX	4940200
FIX2 module	RM 16 T KNX	4940205

Technical data

	RMG 8 T KNX	RME 8 T KNX	RM 16 T KNX	RM 8 T KNX
Operating voltage KNX	Bus voltage, $\leq 4 \text{ mA}$	-	Bus voltage, $\leq 4 \text{ mA}$	
Operating voltage	110–240 V AC	-	110–240 V AC	
Frequency	50–60 Hz	-	50–60 Hz	
Stand-by consumption	0,3 W	0,2 W	0,5 W	
Width	4 modules		8 modules	4 modules
Type of contact	NO contact, 16 A ( $\cos \varphi = 1$ ), 3 A ( $\cos \varphi = 0,6$ )			
Inrush current	max. 800 A / 200 $\mu\text{s}$			
Resistive load	3680 W			
Incandescent lamp load	2000 W			
Fluorescent lamp load (electronic ballast)	1200 W			
Energy saving lamps	300 W			
LED lamp < 2 W	55 W			
LED lamp 2–8 W	180 W			
LED lamp > 8 W	200 W			
Ambient temperature	-5 °C ... +45 °C			
Type of protection	IP 20			
Protection class	II according to EN 60 669			

Connection diagrams

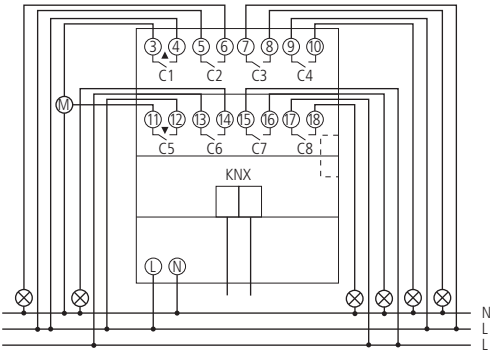

RMG 8 T KNX, RM 8 T KNX

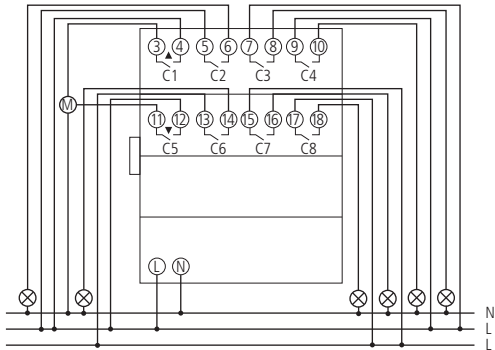

RME 8 T KNX

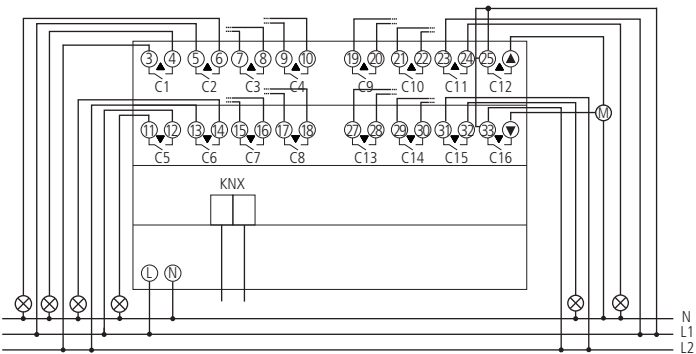

RM 16 T KNX

# Home and building control

## KNX, Blinds actuators



### Description

#### Common functions

- Blind actuator
- For controlling drives for blinds, shutters, sun and vision protection devices, skylights and ventilation flaps
- Manual operation on device (even without bus connection)
- LED Up and Down switching status display for each channel
- Potential-free contacts for Up and Down per channel
- Copy function for fast configuration
- Setting option for phase sequence and running time of devices

#### JMG 4 T KNX

- 4-way blind actuator MIX2
- Base module MIX2
- Can be upgraded to maximum of 12 channels
- Up to two extension modules MIX or MIX2 can be connected to one base module
- Device and KNX bus module can be swapped independently of each other
- Removable KNX bus module enables devices to be changed without reprogramming
- Manual set-up and use of actuators is possible without KNX bus module
- Free combination of switches, dimming, blinds and heating control as well as binary inputs

#### JME 4 T KNX

- 4-way blind actuator MIX2
- Extension module MIX2
- Can be upgraded to maximum of 12 channels

#### JM 4 T KNX

- 4-way blind actuator FIX1

#### JM 8 T KNX

- 8-way blind actuator FIX2

### Product selection

Function	Type	Article number
MIX2 Base module	JMG 4 T KNX	4930250
MIX2 Extension module	JME 4 T KNX	4930255
FIX1 module	JM 4 T KNX	4940250
FIX2 module	JM 8 T KNX	4940255

### Technical data

	JMG 4 T KNX	JME 4 T KNX	JM 8 T KNX	JM 4 T KNX
Operating voltage KNX	Bus voltage, $\leq 4 \text{ mA}$	–	Bus voltage, $\leq 4 \text{ mA}$	
Operating voltage	110–240 V AC	–	110–240 V AC	
Stand-by consumption	0,3 W	0,2 W	0,5 W	0,3 W
Frequency	50–60 Hz	–	50–60 Hz	
Width	4 modules		8 modules	4 modules
Type of contact	NO contact, 6 A ( $\cos \varphi = 1$ )			
Ambient temperature	–5 °C ... +45 °C			
Type of protection	IP 20			
Protection class	II according to EN 60 669			

### Connection diagrams

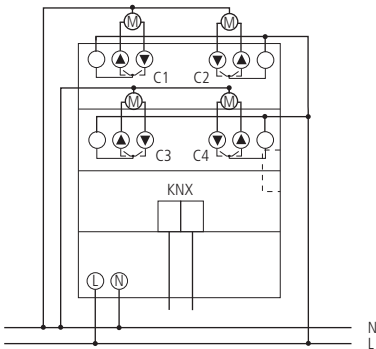

JMG 4 T KNX, JM 4 T KNX

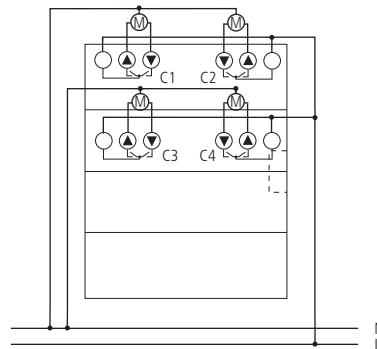

JME 4 T KNX

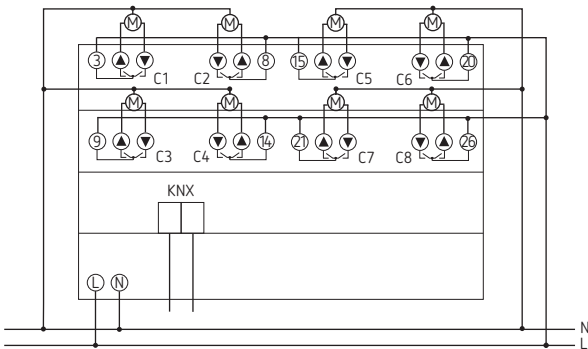

JM 8 T KNX

# Home and building control

## KNX, Blinds actuators



### Description

#### Common functions

- Blind actuator
- For controlling 24V drives for blinds, shutters, sun and vision protection devices, skylights and ventilation flaps
- Manual operation on device (even without bus connection)
- LED Up and Down switching status display for each channel
- Potential-free contacts for Up and Down per channel
- Setting option for phase sequence and running time of devices
- Copy function for fast configuration

#### JMG 4 T 24V KNX

- 4-way blind actuator MIX2
- Base module MIX2
- Can be upgraded to maximum of 12 channels
- Up to two extension modules MIX or MIX2 can be connected to one base module
- Device and KNX bus module can be swapped independently of each other
- Removable KNX bus module enables devices to be changed without reprogramming
- Manual set-up and use of actuators is possible without KNX bus module
- Free combination of switches, dimming, blinds and heating control as well as binary inputs

#### JME 4 T 24V KNX

- 4-way blind actuator MIX2
- Extension module MIX2
- Can be upgraded to maximum of 12 channels

#### JM 4 T 24V KNX

- 4-way blind actuator FIX1

#### JM 8 T 24V KNX

- 8-way blind actuator FIX2

### Product selection

Function	Type	Article number
MIX2 Base module	JMG 4 T 24V KNX	4930260
MIX2 Extension module	JME 4 T 24V KNX	4930265
FIX1 module	JM 4 T 24V KNX	4940260
FIX2 module	JM 8 T 24V KNX	4940265

### Technical data

	JMG 4 T 24V KNX	JME 4 T 24V KNX	JM 4 T 24V KNX	JM 8 T 24V KNX
Operating voltage KNX	Bus voltage, ≤ 4 mA	–	Bus voltage, ≤ 4 mA	
Operating voltage	110–240 V AC	–	110–240 V AC	
Stand-by consumption	0,3 W	–	0,3 W	0,5 W
Frequency	50–60 Hz	–	50–60 Hz	
Width	4 modules			8 modules
Type of contact	Changeover contact			
Switching capacity	6 A (at 24 V DC)			
Ambient temperature	–5 °C ... +45 °C			
Type of protection	IP 20			
Protection class	II according to EN 60 730-1			

### Connection diagrams

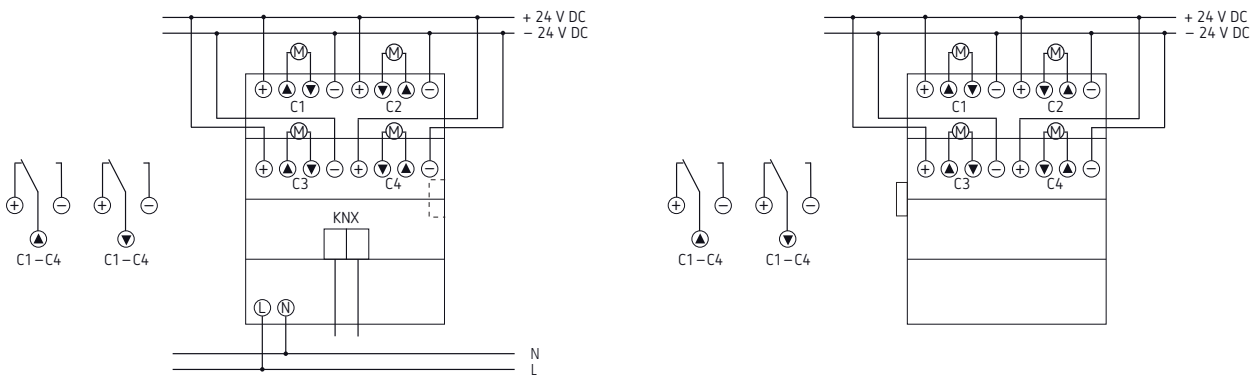

JMG 4 T 24V KNX, JM 4 T 24V KNX

JME 4 T 24V KNX

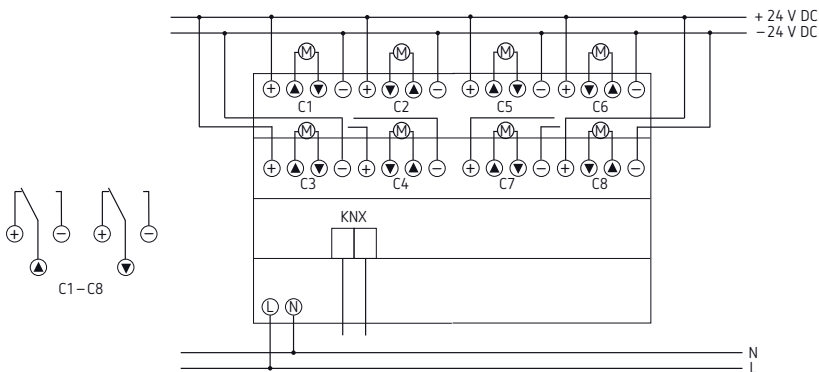

JM 8 T 24V KNX

# Home and building control

## KNX, Blinds actuators



### Description

#### Common functions

- Universal dimmer actuator
- For dimming dimmable LED, incandescent lamps, LV, HV halogen lamps and Energy saving lamps
- Also suitable for dimming of dimmable energy-saving lamps
- Also suitable for controlling fans
- LED switching status display for each channel
- Manual operation on device (even without bus connection)
- The dimming output can be upgraded by using additional dimmboosters „DMB 1 T KNX“ - dimming output 300 W/VA for each dimmbooster. Output to a maximum of 2000 W/VA by using max. 4 boosters possible
- Automatic load detection (can be deactivated)
- For R, L and C loads

#### DMG 2 T KNX

- 2-way universal dimmer actuator MIX2
- Base module MIX2
- Can be upgraded to maximum of 6 channels
- Up to two extension modules MIX or MIX2 can be connected to one base module
- Device and KNX bus module can be swapped independently of each other
- Removable KNX bus module enables devices to be changed without reprogramming
- Manual set-up and use of switching actuators is possible without KNX bus module
- Dimming output: 400 W per channel or 800 W in parallel operation

#### DME 2 T KNX

- 2-way universal dimmer actuator MIX2
- Extension module MIX2
- For upgrading to maximum of 6 channels

#### DM 2 T KNX

- 2-way universal dimmer actuator FIX1

#### DM 4 T KNX

- 4-way universal dimmer actuator FIX2

#### DMB 1 T KNX

- 1 channel dimming output extension module „Dimmbooster“

### Product selection

Function	Type	Article number
MIX2 Base module	DMG 2 T KNX	4930270
MIX2 Extension module	DME 2 T KNX	4930275
FIX1 module	DM 2 T KNX	4940270
FIX2 module	DM 4 T KNX	4940275
Dimmbooster	DMB 1 T KNX	4930279

### Technical data

	DMG 2 T KNX	DME 2 T KNX	DM 4 T KNX	DM 2 T KNX	DMB 1 T KNX
Operating voltage KNX	Bus voltage, $\leq 4$ mA	–	Bus voltage, $\leq 4$ mA		–
Operating voltage	230 V AC				
Frequency	50 Hz				
Stand-by consumption	0,9 W	0,6 W	1,5 W	–	0,2 W
Width	4 modules		8 modules	4 modules	1 modules

	DMG 2 T KNX	DME 2 T KNX	DM 4 T KNX	DM 2 T KNX	DMB 1 T KNX
Lamp types	Incandescent, low-voltage and high-voltage halogen and dimmable energy saving lamps and LED				Incandescent, low-voltage and high-voltage halogen and dimmable LED
Switching capacity per channel	400 W				300 W
Switching capacity in parallel operation	800 W				-
Dimming capacity LED lamp per channel	Trailing edge (RC-mode): 400 W				45 W
Dimming capacity LED lamp in parallel operation	Trailing edge (RC-mode): 800 W				-
Dimming capacity energy saving lamps per channel	Trailing edge (RC-mode): 80 W				-
Dimming capacity energy saving lamps in parallel operation	Trailing edge (RC-mode): 140 W				-
Switching capacity min.	5 W				
Ambient temperature	-5 °C ... +45 °C				
Type of protection	IP 20				
Protection class	II according to EN 60 669				

### Connection diagrams

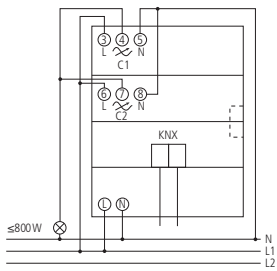

DMG 2 T KNX, DM 2 T KNX

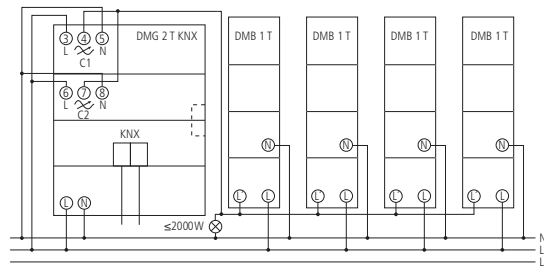

DMG 2 T KNX, DM 2 T KNX

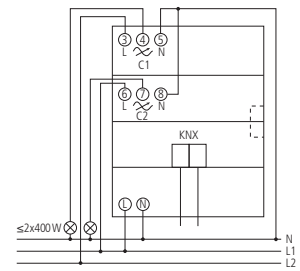

DMG 2 T KNX, DM 2 T KNX

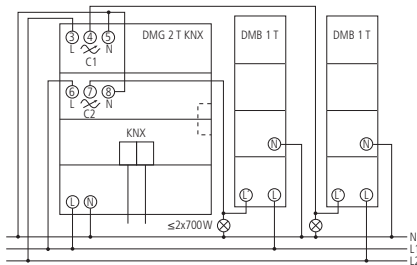

DMG 2 T KNX, DMB 1 T KNX

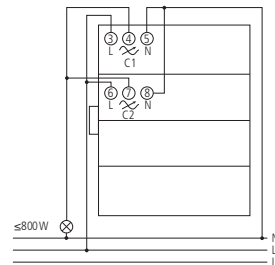

DME 2 T KNX

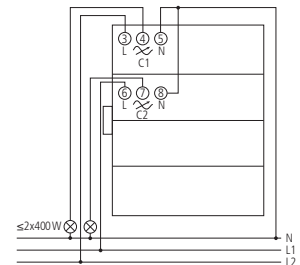

DME 2 T KNX

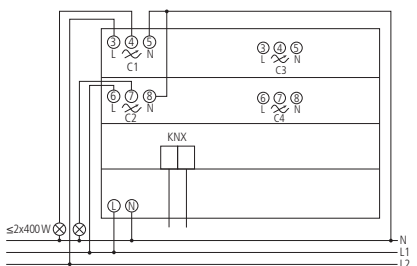

DM 4 T KNX

# Home and building control

## KNX, Dimming actuators



### Description

#### Common functions

- Universal dimmer actuator
- For dimming dimmable LED, incandescent lamps, LV, HV halogen lamps and energy saving lamps
- Also suitable for dimming of dimmable energy-saving lamps
- Also suitable for controlling fans

- LED switching status display for each channel
- Manual operation on device
- Dimming output: 200 W per channel or 400 W in parallel operation
- Automatic load detection (can be deactivated)
- For R, L and C loads

#### DM 4-2 T KNX

- 4-way universal dimmer actuator FIX1

#### DM 8-2 T KNX

- 8-way universal dimmer actuator FIX2

### Description

Function	Number of channels	Type	Article number
FIX1 module	4	DM 4-2 T KNX	4940280
FIX2 module	8	DM 8-2 T KNX	4940285

### Technical data

	DM 4-2 T KNX	DM 8-2 T KNX
Operating voltage KNX	Bus voltage, $\leq 10$ mA	Bus voltage, $\leq 17,5$ mA
Operating voltage	230–240 V AC	
Frequency	50–60 Hz	
Stand-by consumption	< 1 W	
Width	4 modules	8 modules
Lamp types	Incandescent, low-voltage and high-voltage halogen and dimmable energy saving lamps and LED	
Switching capacity per channel	200 W	
Switching capacity in parallel operation	400 W	
Dimming capacity LED lamp per channel	Trailing edge (RC-mode): 200 W	
Dimming capacity LED lamp in parallel operation	Trailing edge (RC-mode): 400 W	
Dimming capacity energy saving lamps per channel	Trailing edge (RC-mode): 200 W	
Dimming capacity energy saving lamps in parallel operation	Trailing edge (RC-mode): 400 W	
Switching capacity min.	2 W	
Ambient temperature	–5 °C ... +45 °C	
Type of protection	IP 20	
Protection class	II according to EN 60 669	

Connection diagrams

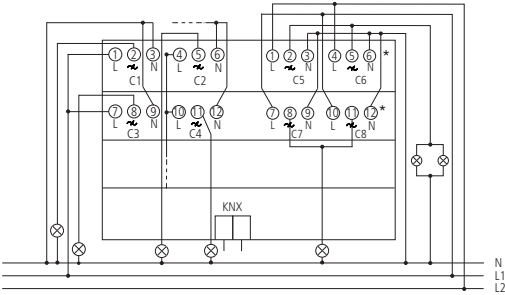

DM 8-2 T KNX

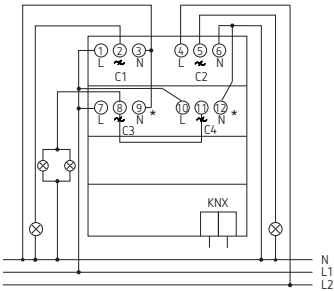

DM 4-2 T KNX

# Home and building control

## KNX, Dimming actuators



SMG 2 S KNX

SME 2 S KNX

### Description

#### Common functions

- 2-way 1–10 V control unit MIX
- Free combination of switching, dimming, blinds and heating control as well as binary inputs
- Switching and dimming of lighting circuits in combination with electronic ballasts (EBs and ballasts LED)

- 1–10 V inputs and one switch output (relay contact) per channel
- LED switching status display for each channel
- Manual switch with On/Off/Bus settings (also without bus voltage)
- Zero-cross switching for relay-saving switching and high lamp loads

#### SMG 2 S KNX

- Base module MIX
- Can be upgraded to maximum of 6 channels

#### SME 2 S KNX

- Extension module MIX
- For upgrading to maximum of 6 channels

### Product selection

Type	Article number
SMG 2 S KNX	4910273
SME 2 S KNX	4910274

### Technical data

	SMG 2 S KNX	SME 2 S KNX
Operating voltage KNX	Bus voltage, ≤ 10 mA	–
Operating voltage	230 V AC	
Frequency	50 Hz	
Stand-by consumption	1,6 W	
Width	4 modules	
Type of contact	NO contact, 16 A (cos φ = 1), 10 A (cos φ = 0,6)	
Incandescent/halogen lamp load	2500 W	
Ambient temperature	–5 °C ... +45 °C	
Type of protection	IP 20	
Protection class	II according to EN 60 730-1	

Connection diagrams

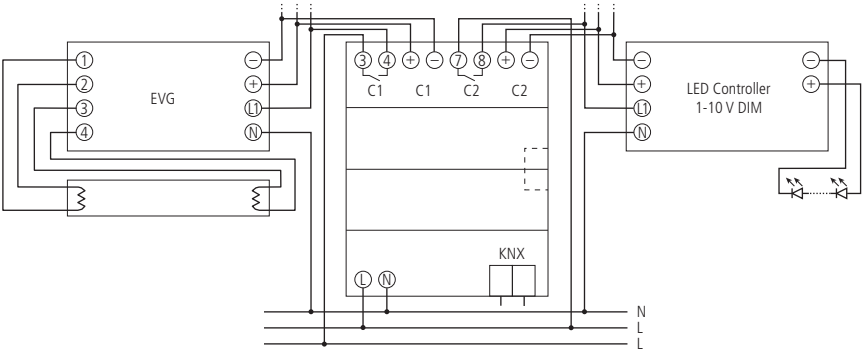

# Home and building control

## KNX, Dimming actuators

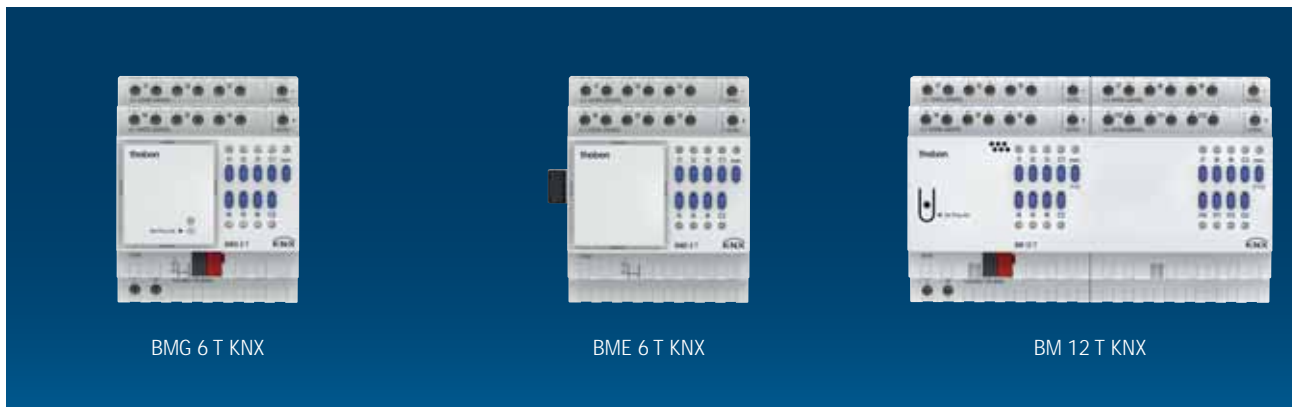

### Description

#### Common functions

- Binary input
- LED switching status display for each channel
- Manual operation on device (even without bus connection)
- Manual operation per channel for simulating the input states
- All inputs can be operated with different voltages and at different potentials
- Connectable cable length up to 100 m
- Free allocation of functions: switch/push button, dimming, blinds/roller blinds, counter, repeat telegram, sequences

#### BMG 6 T KNX

- 6-way binary input MIX2
- Base module MIX2
- Can be upgraded to maximum of 18 channels
- 6 floating universal and wide-range voltage inputs (10–240 V AC/DC or internally generated auxiliary voltage of approx. 12 V DC)
- 2 additional channels operable by buttons on the device, but without input
- Up to two extension modules MIX or MIX2 can be connected to one base module
- Device and KNX bus module can be swapped independently of each other
- Removable KNX bus module enables devices to be changed without reprogramming
- Manual set-up and use of actuator is possible without KNX bus module

#### BME 6 T KNX

- 6-way binary input MIX2
- Extension module MIX2
- For upgrading to maximum of 18 channels

#### BM 6 T KNX

- 6-way binary input FIX1
- 6 floating universal and wide-range voltage inputs (10–240 V AC/DC or internally generated auxiliary voltage of approx. 12 V DC)
- 2 additional channels operable by buttons on the device, but without input

#### BM 12 T KNX

- 12-way binary input FIX2
- 12 floating universal and wide-range voltage inputs (10–240 V AC/DC or internally generated auxiliary voltage of approx. 12 V DC)
- 4 additional channels operable by buttons on the device, but without input

### Product selection

Function	Type	Article number
MIX2 Base module	BMG 6 T KNX	4930230
MIX2 Extension module	BME 6 T KNX	4930235
FIX1 module	BM 6 T KNX	4940230
FIX2 module	BM 12 T KNX	4940235

### Technical data

	BMG 6 T KNX	BME 6 T KNX	BM 12 T KNX	BM 6 T KNX
Operating voltage KNX	Bus voltage, $\leq 4 \text{ mA}$	–	Bus voltage, $\leq 4 \text{ mA}$	
Operating voltage	110–240 V AC	–	110–240 V AC	
Frequency	50–60 Hz	–	50–60 Hz	
Stand-by consumption	0,3 W	–	0,5 W	0,3 W
Width	4 modules		8 modules	4 modules
Voltage inputs	10 V DC – 240 V AC 2 mA			
Ambient temperature	–5 °C ... +45 °C			
Type of protection	IP 20			
Protection class	II according to EN 60 730-1			

### Connection diagrams

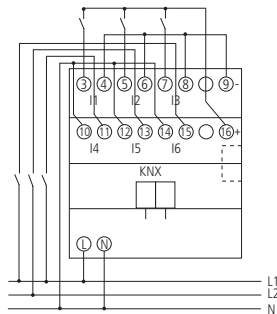

BMG 6 T KNX, BM 6 T KNX

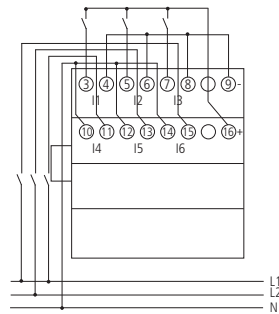

BME 6 T KNX

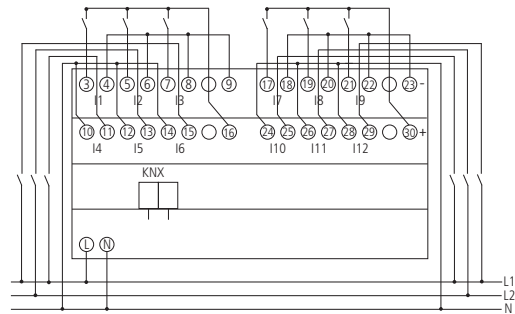

BM 12 T KNX

# Home and building control

## KNX, Binary inputs



### Description

#### Common functions

- Binary input/binary output sensor interfaces
- Can be installed in flush-mounted sockets with conventional sensors/switches
- Flexible LED controlling, thanks to increased output current of 3 mA commercially available LEDs and low current LEDs can be controlled
- Inputs can be reconfigured to outputs with parameterizable flashing and pulsing function
- Colour coding of wiring pairs

#### TA 2 S KNX

- 2-way key interface
- 4-pole cable connection
- Free allocation of functions: Switch/key, dimming, blinds, valuator, sequences, controlling LED

#### TA 4 S KNX

- 4-way key interface
- 6-pole cable connection
- Free allocation of functions: Switch/key, dimming, blinds, valuator, sequences, measuring temperature, controlling LED

- 2 NTC inputs for detection of the actual temperature

#### TA 6 S KNX

- As TA 4 S KNX, but:
- 6-way key interface
  - 8-pole cable connection

#### TA 8 S KNX

- As TA 4 S KNX, but:
- 8-way key interface
  - 10-pole cable connection

### Product selection

Type	Article number
TA 2 S KNX	4969222
TA 4 S KNX	4969224
TA 6 S KNX	4969226
TA 8 S KNX	4969228

### Technical data

	TA S KNX
Operating voltage KNX	Bus voltage, ≤10 mA
Length connecting wires	25 cm
Contact current	0,5 mA
Ambient temperature	-5 °C ... +45 °C
Type of protection	IP 20
Protection class	III

12

### Accessories

#### External temperature sensor 1

Details page 343

#### Temperature sensor

Details page 343

#### Temperature sensor RAMSES IP 65

Details page 343

### Scale drawings

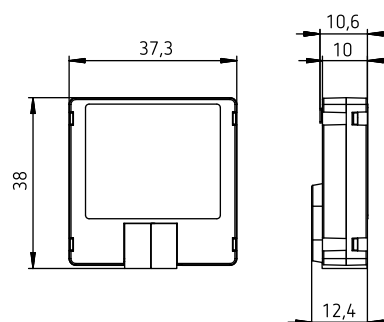



VARIA 826 S KNX

VARIA 826 S KNX

## Description

### Common functions

- Multi-functional display with room thermostat
- Glass front in white or black
- Freely configurable for displaying and controlling functions e.g. light settings, sun protection systems
- Backlit display and integrated time switch

- For control and regulation of heating, fan coils, air conditioning systems
- Up to 7 different display pages
- Automatic summer/winter time adjustment with power reserve
- Controls up to 8 rooms via own temperature profiles
- Weekly time switch with 8 channels with up to 3 different statuses, e.g. for light, shutters, fans etc.

- 3 heating programs
- Alternative continuous or on/off control
- Operation modes: comfort, stand-by, temperature reduction at night, frost protection
- Weather data from Theben weather stations can be displayed
- Free choice of programming via the ETS without plug-in
- Installation in flush-mounted socket

## Product selection

Colour	Type	Article number
Glass front in white	VARIA 826 S WH KNX	8269210
Glass front in black	VARIA 826 S BK KNX	8269211

## Technical data

	VARIA 826 S WH KNX	VARIA 826 S BK KNX
Operating voltage KNX	Bus voltage, ≤ 15 mA, (< 25 mA without power supply)	
Operating voltage	230 V AC	
Frequency	50 Hz	
Stand-by consumption	0,4 W	
Power reserve	1,5 years	
Display	Display with 132 x 72 points (8 lines with various functions) e.g. title, switching, dimming, blinds/shutters, % value, HVAC, counter value, temperature, 2-byte value, 8/16 bit counter value etc.	
Ambient temperature	0 °C ... +45 °C	
Type of protection	IP 20	
Protection class	II according to EN 60 730-1	

## Scale drawings

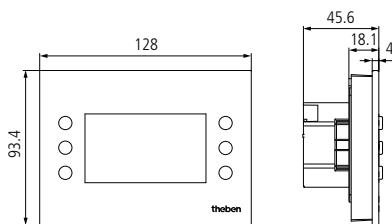

# Home and building control

## KNX, HVAC controller



### Description

- Individual room thermostat
- For controlling heating actuators or motorised actuators
- Can be used as a continuous or two point control (can also be combined).
- Continuous PI control can be configured for 2 stage heating (basic and additional stage, e. g. underfloor heating and radiators) or for heating and cooling (radiators and cooling surfaces)
- Two front panels are included in delivery: a numerical scale and a relative scale
- Rotary control can be limited via parameters
- Manual override button for presence or operation modes: comfort, stand-by, temperature reduction at night, frost protection
- 4 binary inputs for conventional switches/sensors (switching, dimming, blinds), also for external temperature sensor, window contact or presence signal
- Temperature sensor can be connected to give remote temperature reading
- LED (red) for heating mode, (blue) for cooling mode, LEDs for operation mode

### Product selection

Type	Article number
RAMSES 718 P KNX	7189210

### Technical data

RAMSES 718 P KNX			
Operating voltage KNX	Bus voltage, ≤ 12 mA	Setting range temperature	+10 °C ... +30 °C
Interface extension max.	30 m	Type of protection	IP 20
Ambient temperature	+5 °C ... +40 °C	Protection class	III according to EN 60 730-1
Measuring range temperature	-5 °C ... +45 °C		

### Accessories

- External temperature sensor 1  
Details page 343
- Temperature sensor  
Details page 343
- Temperature sensor RAMSES IP 65  
Details page 343

### Scale drawings

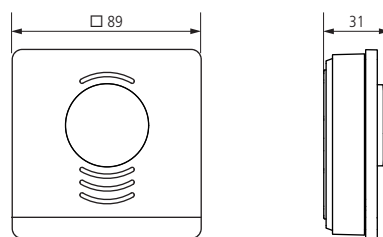

RAMSES 718 P KNX



### Description

- Individual room thermostat
- For controlling heating actuators or motorised actuators
- Can be used as a continuous or two point control (can also be combined)
- Temperature sensor can be connected to give remote temperature reading
- Objects for night operation (only with „old“ operation mode selection) presence, window/frost
- LED (red) for heating mode, (blue) for cooling mode
- 4 binary inputs for conventional switches/sensors (switch/sensor, dimmer, blinds, valuator, LED control)

### Product selection

Type	Article number
RAMSES 718 S KNX	7189200

### Technical data

RAMSES 718 S KNX			
Operating voltage KNX	Bus voltage, ≤ 12 mA	Setting range temperature	+10 °C ... +30 °C
Interface extension max.	30 m	Type of protection	IP 20
Ambient temperature	+5 °C ... +40 °C	Protection class	III according to EN 60 730-1
Measuring range temperature	-5 °C ... +45 °C		

### Accessories

- External temperature sensor 1  
Details page 343
- Temperature sensor  
Details page 343
- Temperature sensor RAMSES IP 65  
Details page 343

### Scale drawings

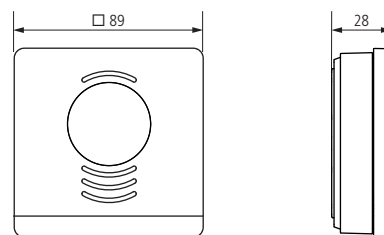

RAMSES 718 S KNX

# Home and building control

## KNX, HVAC controller

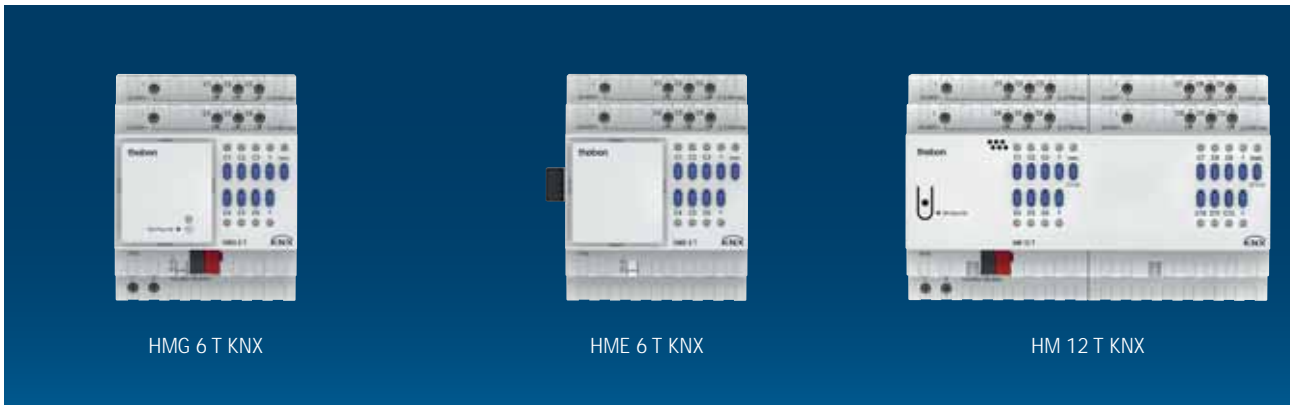

### Description

#### Common functions

- Heating actuator
- Short-circuit-proof and overcharge protected
- Continuous or switching actuating value selectable
- Valve protection function can be deactivated
- With the modes: comfort, standby, night as well as frost/heating protection
- Changeover to summer mode possible
- LED switching status display for each channel
- Manual operation on device (even without bus connection)

#### HMG 6 T KNX

- 6-way heating actuator MIX2
- With 6 temperature controllers (P/PI) for heating and cooling
- Base module MIX2
- Can be upgraded to maximum of 18 channels
- For controlling 6 thermal actuators 24 V–240 V AC in 2 groups with 3 outputs and 450 mA each
- Up to two extension modules MIX or MIX2 can be connected to one base module
- Device and KNX bus module can be swapped independently of each other
- Removable KNX bus module enables devices to be changed without reprogramming
- Manual set-up and use of actuator is possible without KNX bus module

#### HME 6 T KNX

- 6-way heating actuator MIX2
- With 6 temperature controllers (P/PI) for heating and cooling
- Extension module MIX2
- For upgrading to maximum of 18 channels

#### HM 6 T KNX

- 6-way heating actuator FIX1
- With 6 temperature controllers (P/PI) for heating and cooling
- For controlling 6 thermal actuators 24 V–240 V AC in 2 groups with 3 outputs and 450 mA each

#### HM 12 T KNX

- 12-way heating actuator FIX2
- With 12 temperature controllers (P/PI) for heating and cooling
- For controlling 12 thermal actuators 24 V–240 V AC in 4 groups with 3 outputs and 450 mA each

### Product selection

Function	Type	Article number
MIX2 Base module	HMG 6 T KNX	4930240
MIX2 Extension module	HME 6 T KNX	4930245
FIX1 module	HM 6 T KNX	4940240
FIX2 module	HM 12 T KNX	4940245

### Technical data

	HMG 6 T KNX	HME 6 T KNX	HM 12 T KNX	HM 6 T KNX
Operating voltage KNX	Bus voltage, ≤ 4 mA	–	Bus voltage, ≤ 12 mA	Bus voltage, ≤ 4 mA
Operating voltage	110–240 V AC	–	110–240 V AC	
Frequency	50–60 Hz	–	50–60 Hz	
Stand-by consumption	0,3 W	0,2 W	0,5 W	0,3 W
Width	4 modules		8 modules	4 modules
Switching output	Not potential-free			
Output	Triac, 0,45 A			
Ambient temperature	–5 °C ... +45 °C			
Type of protection	IP 20			
Protection class	II according to EN 60 669			

### Accessories



Actuator ALPHA 5 230 V

↳ Art.No.: 9070441

Details page 344



Actuator ALPHA 5 24 V

↳ Art.No.: 9070442

Details page 344

### Connection diagrams

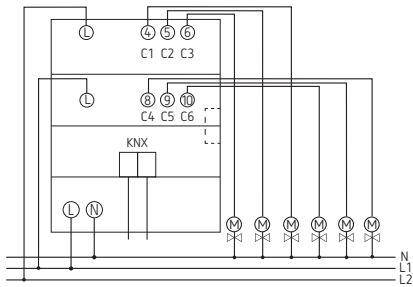

HMG 6 T KNX, HME 6 T KNX

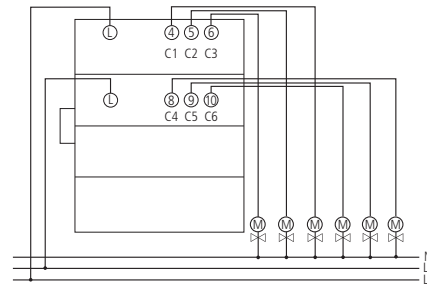

HME 6 T KNX

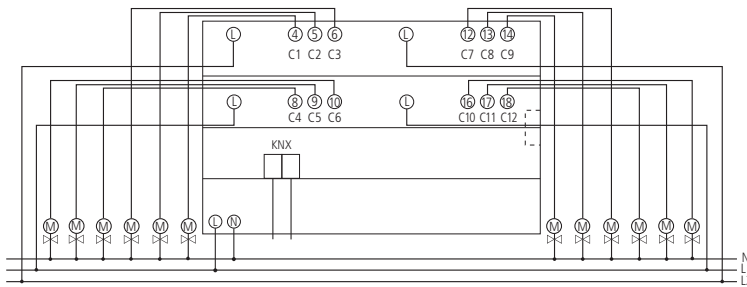

HM 12 TKNX

# Home and building control

## KNX, HVAC controller



HMT 6 S KNX



### Description

- Heating actuator for controlling thermal actuators, switching 24 V DC or permanently 0–10 V DC
- Integration of up to 2 heating circuit pumps
- Flow temperature adjustment to meet requirements: Automatic calculation of the maximum actuating value for energy-efficient adjustment of the actuating value to actual requirements
- No KNX room thermostat needed: Flexible use of each channel as a heating actuator or heating controller
- Can be installed directly on a rail in the heating circuit distributor
- Screwless terminal technology
- Integrated power supply for a maximum of 12 thermal actuators
- Silent semiconductor switch (triac)
- For integrating boiler control
- Continuous or switching actuating value selectable

HMT 6 KNX

- 6-way

HMT 12 KNX

- 12-way

### Product selection

Type	Article number
HMT 6 S KNX	4900373
HMT 12 S KNX	4900373

### Technical data

	HMT 6 S KNX	HMT 12 S KNX
Operating voltage KNX	Bus voltage, ≤ 10 mA	
Operating voltage	230–240 V AC	
Stand-by consumption	< 1 W	
Frequency	50–60 Hz	
Number of channels	6	12
Switching capacity	Valve output: 24 V SELV; 0.4 A peak; 0.12 A permanent or 0-10 V at at least 1250 ohm 24 V output terminal: max. 1.4 A	
Switch output	5 A, 240 V AC floating (pump)	
Ambient temperature	-5 °C ... +50 °C	
Type of protection	IP 20	
Protection class	II according to EN 60 730-1	

### Accessories



Actuator ALPHA 5 24 V

↳ Art.No.: 9070442

Details page 344

### Scale drawings

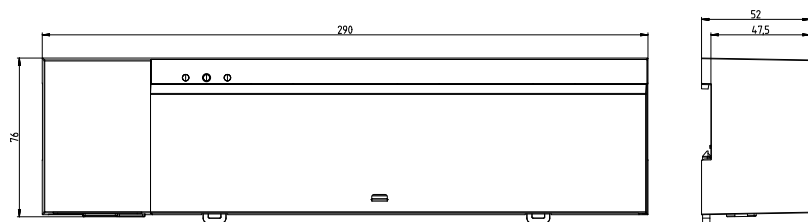

HMT 6 S KNX, HMT 12 S KNX

### Connection diagrams

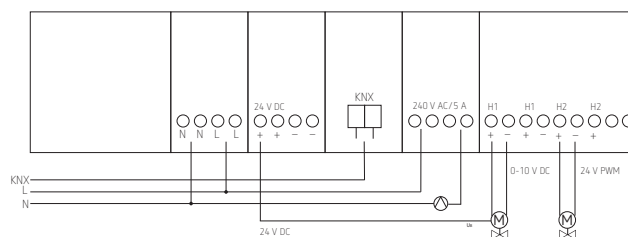

HMT 6 S KNX

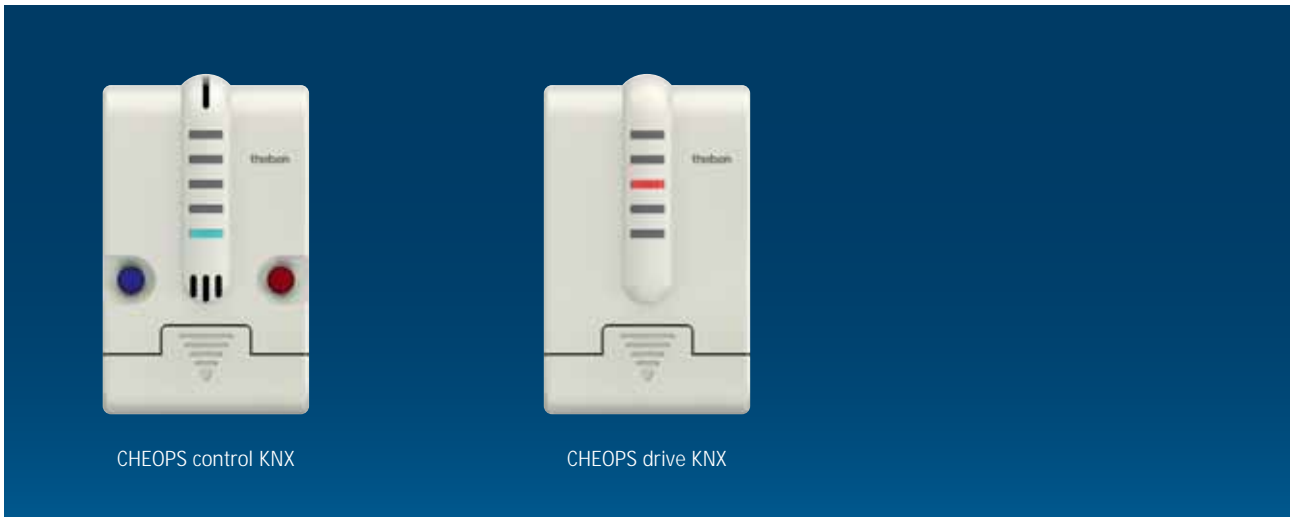

### Description

#### Common functions

- Motorised actuator for heater valve or for controlling the heating valves
- Display of valve stroke
- Automatic valve stroke recognition
- 2 inputs for window contact, presence detector, remote sensor (remote sensor only for CHEOPS control and only 9070191)
- Simple installation by clicking onto valve adapter
- Can be used in heating circuit distributor

- Integrated bus coupling unit
- With summer mode and valve protection
- 2 different valve adapters included (VA 10, VA 78)

#### CHEOPS control KNX

- Independent room thermostat and integrated temperature sensor
- Manual operation possible via 2 keys on the device
- Display via LEDs (red/blue for hotter/colder)
- Configurable as: Heating control (continuous control), two stage heating, heating and cooling

#### CHEOPS drive KNX

- Without integrated control
- Display via LEDs (red)

### Product selection

Type	Article number
CHEOPS control KNX	7329201
CHEOPS drive KNX	7319200

### Technical data

	CHEOPS control KNX	CHEOPS drive KNX
Operating voltage KNX	Bus voltage, ≤ 10 mA	
Max. valve stroke	7,5 mm	
Controlling torque details	120 N	
Ambient temperature	0 °C ... +50 °C	
Dimensions	50 mm, 82 mm, 65 mm	
Protection class	III according to EN 60730-2-14	
Type of protection	IP 20	IP 21

### Accessories

#### External temperature sensor 1

Details page 343

#### Valve adapter VA 80

Details page 344

### Scale drawings

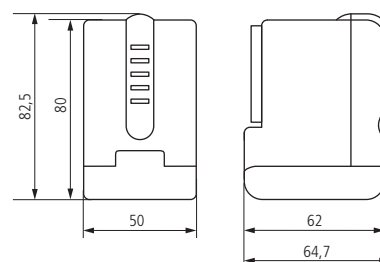

# Home and building control

## KNX, HVAC controller



### Description

- CO<sub>2</sub> airquality sensor with integrated individual room thermostat
- Measures CO<sub>2</sub> level, relative humidity, temperature and barometric air pressure
- Three independent, configurable thresholds for the CO<sub>2</sub> level and relative humidity
- CO<sub>2</sub> setting range of 300-5000 ppm
- Actions can be carried out if thresholds are exceeded or not reached (send, priority, switching, value)
- For controlling heating actuators or motorised actuators
- Two front panels are included in delivery: a numerical and a relative scale
- Manual override button for presence or operation modes: comfort, stand-by, temperature reduction at night, frost protection
- 4 binary inputs for conventional switches/sensors (switching, dimming, blinds), also for external temperature sensor, window contact or presence signal
- Display of the current operating mode and heating/cooling mode through multi-colored LED

### Product selection

Type	Article number
AMUN 716 S KNX	7169230

### Technical data

AMUN 716 S KNX			
Operating voltage KNX	Bus voltage, ≤ 15 mA	Contact voltage	5 V, Internal provided
Measuring range CO <sub>2</sub>	300–5000 ppm	Contact current	0,5 mA
Measuring range temperature	-5 °C ... +45 °C	Number of inputs	4
Measuring range humidity	1–100 % rH	Ambient temperature	+5 °C ... +40 °C
Measuring range air pressure	30000–110000 Pa	Type of protection	IP 20
Interface extension max.	30 m	Protection class	III according to EN 60 730-1

### Accessories

#### External temperature sensor 1

Details page 343

#### Temperature sensor

Details page 343

#### Temperature sensor RAMSES IP 65

Details page 343

### Scale drawings

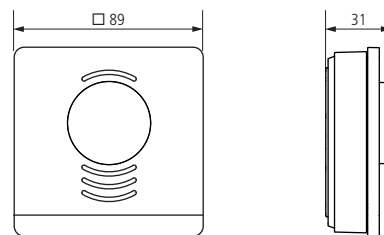

AMUN 716 KNX



RAMSES 713 FC KNX

### Description

- Individual room thermostat fan coil
- For control of fan coil
- Continuous PI controller for heating and cooling
- Two rotary controls are included in delivery: an absolute scale (mounted) and 1 relative scale (enclosed)
- Rotary control can be limited mechanically or via parameters.
- Manual button for OFF, Auto, fan stages 1, 2, 3 operation modes
- 3 binary inputs for conventional switches/sensors (switching, dimming, blinds), also for external temperature sensor, window contact or presence signal
- LED (red) for heating mode, (blue) for cooling mode
- With integrated bus coupling unit

### Product selection

Type	Article number
RAMSES 713 FC KNX	7139202

### Technical data

RAMSES 713 FC KNX			
Operating voltage KNX	Bus voltage, ≤ 10 mA	Setting range temperature	+10 °C ... +28 °C
Ambient temperature	+0 °C ... +50 °C	Type of protection	IP 20
Measuring range temperature	+0 °C ... +40 °C	Protection class	II according to EN 60 730-1

### Accessories

External temperature sensor 1

Details page 343

Temperature sensor

Details page 343

### Scale drawings

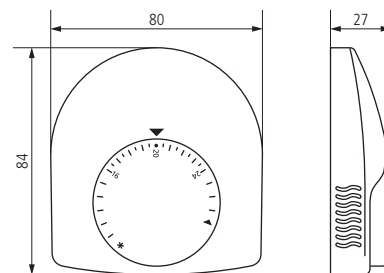

RAMSES 713 FC KNX

# Home and building control

## KNX, HVAC controller



FCA 1 KNX

FCA 2 KNX

### Description

#### Common functions

- Fan coil actuator
- For controlling fan coils
- For 2 and 4 pipe systems
- For up to three fan stages
- Additional relay for electrical heater or cooler bank
- Potential-free input for window contacts or temperature sensor
- Potential-free, condensation monitoring
- Display of operation status via 9 LEDs
- Manual operation on device (fan stages, switching between heating and cooling)
- Adjustment of setpoint value for cooling in relation to external temperature
- Potential-free switching contact for either cooler or heater bank
- With emergency program

#### FCA 1 KNX

- For 2-way and 3-way valves

#### FCA 2 KNX

- Optionally with 0-10 V fan control
- For proportional 0-10 V valves

### Product selection

Type	Article number
FCA 1 KNX	4920200
FCA 2 KNX	4920210

### Technical data

	FCA 1 KNX	FCA 2 KNX
Operating voltage KNX	Bus voltage, ≤10 mA	Bus voltage, ≤8 mA
Operating voltage	220–230 V AC	100–240 V AC
Frequency	50–60 Hz	
Stand-by consumption	1,9 W	0,5 W
Width	4 modules	
Type of contact	Triac	NO contact
Switching capacity additional relay	16 A	
Switching capacity blower relay	8 A	6 A
Ambient temperature	-5 °C ... +45 °C	
Type of protection	IP 20	
Protection class	II according to EN 60 730-1	

Accessories

Temperature sensor  
↳ Art.No.: 9070321  
Details page 343



Connection diagrams

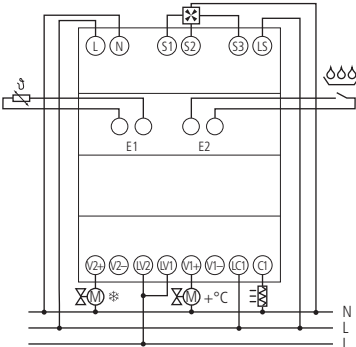

FCA 1 KNX

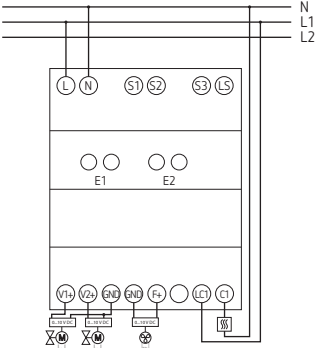

FCA 2 KNX

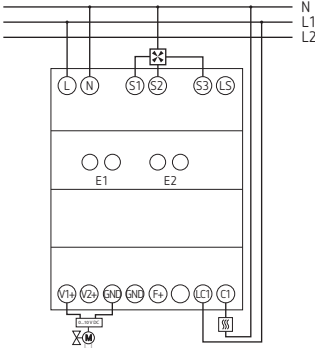

FCA 2 KNX

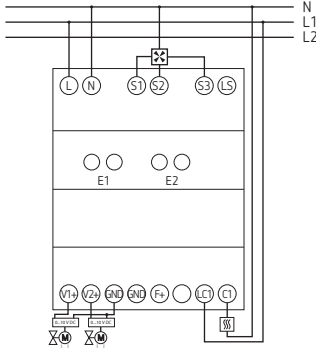

FCA 2 KNX

# Home and building control

## KNX, Presence detectors



### Description

- Presence detector (PIR)
- Automatic control of lighting depending on presence and brightness
- Square detection area allows accurate and simple planning
- Cover frame in white included in delivery, cover frames in black or silver available as optional accessories
- Integrated bus coupling unit
- IP 54 for versatile use
- 2 channels light for controlling one or two lighting groups
- Mixed light measurement, suitable for fluorescent lamps (FL/PL/ESL), halogen/incandescent lamps and LEDs
- Switching or constant light control with stand-by function
- Adjustable sensitivity
- Choice of fully or semi automatic operation: In „Semi-automatic“ mode the light must be switched on manually and switches off automatically
- Short presence; Reduced switch-off delay time in case of a short presence
- Self-learning time delay
- Channel presence with switch-off delay and switch-on delay time and send values
- Function „monitoring“ with reduced sensitivity only to detect walking persons
- Channel brightness (Lux)
- Set brightness level via bus object
- Scene functionality (8-bit scenes)
- Selected parameters can be configured remotely using the SendoPro remote control. Parameter settings are made via ETS
- Optional user remote control
- Ready for use by ex-factory set items
- Test operation to check detection area and installation
- Parallel switching of several presence detectors (master-slave or master-master) possible
- Ceiling mounting in flush-mounted box
- Possibility of surface mounting by using a surface frame

### Product selection

Installation type	Colour	Type	Article number
Ceiling installation	Pure white (similar to RAL 9010)	PresenceLight 360B-KNX WH	2009000

### Technical data

	PresenceLight 360B-KNX
Operating voltage KNX	Bus voltage, approx. 13 mA (17 mA LED on)
Installation height	2–3,5 m
Setting range brightness	approx. 5–2000 lx/measuring off
Light switch-off delay	30 s–60 min
Stand-by time light	30 s–60 min, on, inactive
Presence switch-off delay	10 s–120 min
Presence switch-on delay	10 s–30 min/inactive
Ambient temperature	–10 °C ... +50 °C
Type of protection	IP 54

Detection range (Square)

Mounting height (A)	Walking (T)	Sitting (S)
2 m	20 m <sup>2</sup>   4,5 m x 4,5 m ± 0,5 m	9 m <sup>2</sup>   3 m x 3 m
2,5 m	36 m <sup>2</sup>   6 m x 6 m ± 0,5 m	16 m <sup>2</sup>   4 m x 4 m
3 m	49 m <sup>2</sup>   7 m x 7 m ± 1 m	20 m <sup>2</sup>   4,5 m x 4,5 m
3,5 m	64 m <sup>2</sup>   8 m x 8 m ± 1 m	-

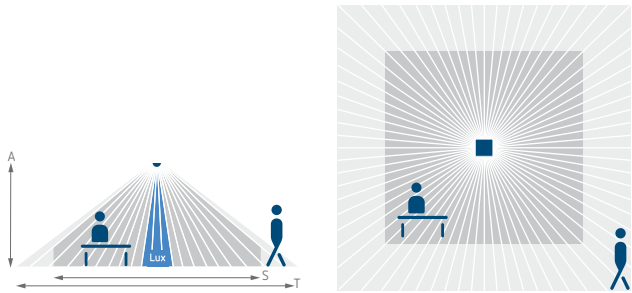

Accessories



Surface frame PresenceLight  
↳ Art.No.: 9070513  
Details page 336



SendoPro 868-A  
↳ Art.No.: 9070675  
Details page 339



QuickSafe  
↳ Art.No.: 9070531  
Details page 338



theSenda P  
↳ Art.No.: 9070910  
Details page 341



theSenda S  
↳ Art.No.: 9070911  
Details page 341

Cover frame PresenceLight 360 SR  
Details page 336

Cover frame PresenceLight 360 BK  
Details page 336

Surface frame PresenceLight BK  
Details page 336

Surface frame PresenceLight SR  
Details page 336

Scale drawings

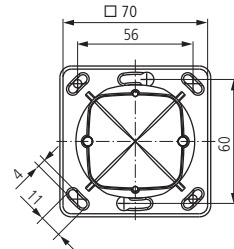
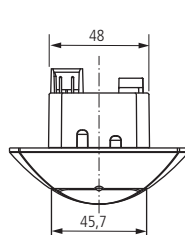
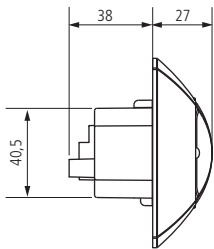
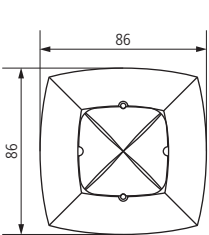

# Home and building control

## KNX, Presence detectors



### Description

#### Common functions

- Presence detector (PIR)
  - Mixed light measurement
  - Two channels light for controlling two lighting groups
  - Switching or constant light control
  - Choice of fully or semi automatic operation
  - Presence output for HVAC control with switch-on delay and switch-off delay
  - Room monitoring with selective movement detection
  - Integrated bus coupling unit
  - SendoPro 868-A service remote control (optional)
  - Clic user remote control (optional)
- In the „switching“ operation mode, lighting switches on with darkness and presence and off with sufficient light or when nobody is present. In the „constant light control“ operation mode the sensor controls the artificial light daylight-dependent on a constant lighting level
  - The self-learning switch-off delay time adjusts to occupants' behaviour
  - Fully or semi-automatic: In „Fully automatic“ mode, the lighting switches on and off automatically according to presence and light. In „Semi-automatic“ mode, it must be switched on manually and it switches off automatically
  - The monitoring output works with reduced sensitivity and indicates the presence of persons with a high level of accuracy
- The brightness output makes the light information available for visualisation purposes
  - Master or slave operating mode is selected via configuration
  - Test operation mode checks the detection area and configuration
  - A maximum of 10 detectors can be switched at the same time

#### compact passage KNX

- Rectangular detection area for corridors

#### compact passimo KNX

- Rectangular detection area for storage areas with clear demarcation vertically below the presence detector

### Product selection

Installation type	Colour	Type	Article number
Ceiling installation	Pure white (similar to RAL 9010)	compact passage KNX	2019290
	Black (similar to RAL 9005)	compact passage KNX BK	2019803
	Silver (similar to RAL 9006)	compact passage KNX SR	2019804
	Pure white (similar to RAL 9010)	compact passimo KNX WH	2019280
	Black (similar to RAL 9005)	compact passimo KNX BK	2019809
	Silver (similar to RAL 9006)	compact passimo KNX SR	2019810

### Technical data

	compact passage KNX/compact passimo KNX
Operating voltage KNX	Bus voltage, approx. 8 mA (9,5 mA LED on)
Installation height	2–6 m
Setting range brightness	approx. 10–1500 lx/measuring off
Light switch-off delay	30 s–20 min
Stand-by time	0 s–60 min/on
Presence switch-off delay	30 s–120 min
Switch-on delay presence	0 s–30 min
Ambient temperature	0 °C ... +50 °C
Type of protection	IP 40 (when fitted)

## Detection range compact passage KNX (Rectangular)

Mounting height (A)	Diagonally (t)	Head on to (r)
2 m	56 m <sup>2</sup>   16 m x 3,5 m ± 1,5 m	56 m <sup>2</sup>   16 m x 3,5 m ± 1,5 m
2.5 m	88 m <sup>2</sup>   22 m x 4 m ± 1,5 m	72 m <sup>2</sup>   18 m x 4 m ± 1,5 m
3 m	135 m <sup>2</sup>   30 m x 4,5 m ± 1,5 m	90 m <sup>2</sup>   20 m x 4,5 m ± 1,5 m
3.5 m	150 m <sup>2</sup>   30 m x 5 m ± 1,5 m	100 m <sup>2</sup>   20 m x 5 m ± 1,5 m
4 m	150 m <sup>2</sup>   30 m x 5 m ± 2 m	100 m <sup>2</sup>   20 m x 5 m ± 2 m
4.5 m	150 m <sup>2</sup>   30 m x 5 m ± 2 m	100 m <sup>2</sup>   20 m x 5 m ± 2 m
5 m	150 m <sup>2</sup>   30 m x 5 m ± 2,5 m	100 m <sup>2</sup>   20 m x 5 m ± 2,5 m
6 m	150 m <sup>2</sup>   30 m x 5 m ± 2,5 m	100 m <sup>2</sup>   20 m x 5 m ± 2,5 m

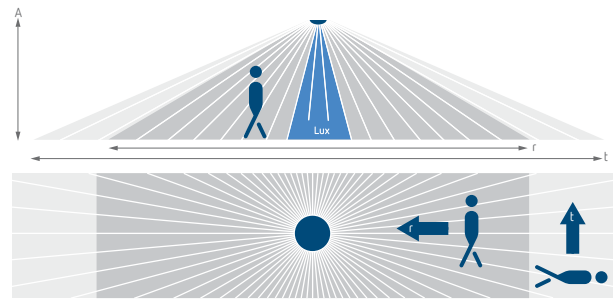

## Detection range compact passimo KNX (Rectangular)

Mounting height (A)	Diagonally (t)	Head on to (r)
2 m	28 m <sup>2</sup>   8 m x 3,5 m ± 1,5 m	28 m <sup>2</sup>   8 m x 3,5 m ± 1,5 m
2.5 m	44 m <sup>2</sup>   11 m x 4 m ± 1,5 m	36 m <sup>2</sup>   9 m x 4 m ± 1,5 m
3 m	68 m <sup>2</sup>   15 m x 4,5 m ± 1,5 m	45 m <sup>2</sup>   10 m x 4,5 m ± 1,5 m
3.5 m	75 m <sup>2</sup>   15 m x 5 m ± 1,5 m	50 m <sup>2</sup>   10 m x 5 m ± 1,5 m
4 m	75 m <sup>2</sup>   15 m x 5 m ± 2 m	50 m <sup>2</sup>   10 m x 5 m ± 2 m
4.5 m	75 m <sup>2</sup>   15 m x 5 m ± 2 m	50 m <sup>2</sup>   10 m x 5 m ± 2 m
5 m	75 m <sup>2</sup>   15 m x 5 m ± 2,5 m	50 m <sup>2</sup>   10 m x 5 m ± 2,5 m
6 m	75 m <sup>2</sup>   15 m x 5 m ± 2,5 m	50 m <sup>2</sup>   10 m x 5 m ± 2,5 m

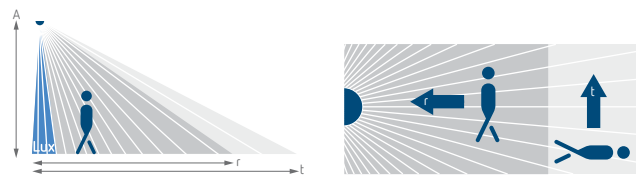

## Accessories



Surface frame compact

↳ Art.No.: 9070514

Details page 337



SentoPro 868-A

↳ Art.No.: 9070675

Details page 339



Ceiling installation box 73A

↳ Art.No.: 9070917

Details page 337

QuickSafe

Details page 338

Surface frame compact BK

Details page 337

Surface frame compact SR

Details page 337

## Scale drawings

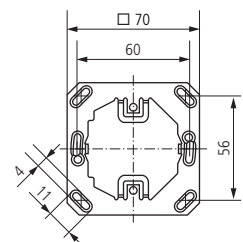
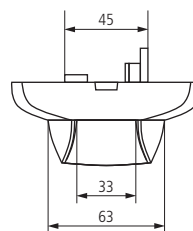
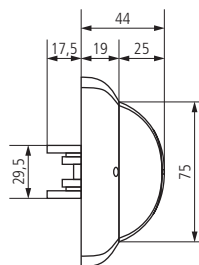
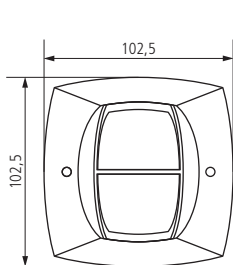

# Home and building control

## KNX, Presence detectors



### Description

- KNX Passive infrared presence detector for ceiling installation
- Circular detection area 360°, up to Ø 9 m (64 m²)
- Automatic presence- and brightness-dependent control for lighting and HVAC
- Mixed light measurement suitable for fluorescent (FL/PL/ESL), halogen/ incandescent lamps and LEDs
- 2 light channels C1, C2
- Switching operation or constant light control with standby function (orientation light)
- Switching mode with dimmable lighting
- Choice of fully or semi-automatic
- Brightness switching value or set point value can be set in lux by using parameters, the object or via remote control
- Teach-in of the brightness switching value or the set point value
- Reduction of time delay when present briefly (short-term presence)
- Manual override by telegram or remote control
- 2 presence channels C4, C5, individually configurable
- Switch-on delay and time delay configurable
- Setting the room correction factor for brightness measurement comparison
- Adjustable sensitivity
- Test mode for checking function and detection area
- Scenes
- Parallel switching of multiple presence detectors (Master/Slave or Master/Master)
- User remote control «theSenda S» (option)
- Management remote control «SendoPro 868-A» (option)
- Installation remote control «theSenda P» (option)

### Product selection

Installation type	Colour	Type	Article number
Ceiling installation	White	theRonda S360 KNX AP WH	2089550
	Grey	theRonda S360 KNX AP GR	2089551
	White	theRonda S360 KNX DE WH	2089560
	Grey	theRonda S360 KNX DE GR	2089561

### Technical data

	theMova S360 KNX AP	theMova S360 KNX DE
Operating voltage KNX	Bus voltage, 9 mA	
Installation height	2–4 m	
Setting range brightness	approx. 30–3000 lx/measuring off	
Light switch-off delay	30 s–60 min	
Presence switch-off delay	10 s–120 min	
Presence switch-on delay	10 s–30 min/inactive	
Ambient temperature	–15 °C ... +50 °C	
Type of protection	IP 54 (when fitted)	

Detection range (Round)

Mounting height (A)	Sitting (S)	Walking (T)
2 m	5 m <sup>2</sup>   2,5 m	38 m <sup>2</sup>   7 m
2,5 m	7 m <sup>2</sup>   3 m	38 m <sup>2</sup>   7 m
3 m	13 m <sup>2</sup>   4 m	50 m <sup>2</sup>   8 m
3,5 m	-	50 m <sup>2</sup>   8 m
4 m	-	64 m <sup>2</sup>   9 m

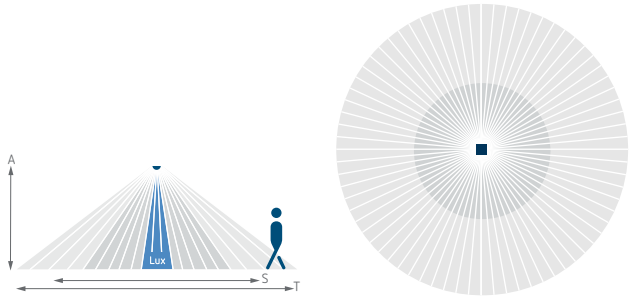

Accessories



SendoPro 868-A  
↳ Art.No.: 9070675  
Details page 339



theSenda P  
↳ Art.No.: 9070910  
Details page 341



theSenda S  
↳ Art.No.: 9070911  
Details page 341

Scale drawings

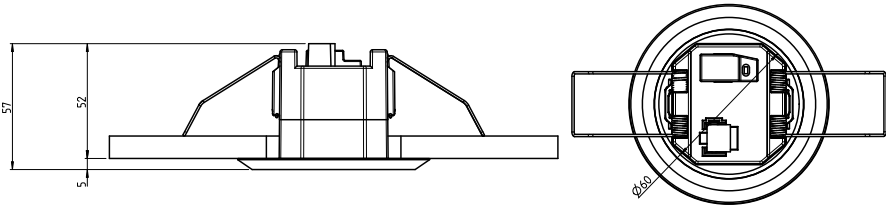

theRonda S360 KNX FLAT DE

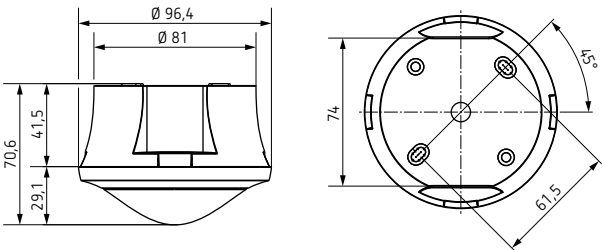

theRonda S360 KNX AP



### Description

- KNX Passive infrared presence detector for ceiling mounting
- Round detection area 360°, up to Ø 24 m (452 m<sup>2</sup>)
- 2 channels light and 2 channels presence
- 2 channels light C1, C2 with 1 light measurement
- 2 presence channels can be parametrized individually
- Adaptable 1 channel light measurement
- Mixed light measurement suitable for LEDs, fluorescent lamps (FL/PL/ESL) and halogen/incandescent lamps
- Can be used as fully or semi-automatic, switchable
- Switch or constant light control mode with stand-by function
- Dimmable lighting in switch mode with stand-by function
- Brightness switching value or set point value can be set in lux using parameters, on the device itself or via remote control
- Teaching in of the brightness switching value or the set point value
- Room correction factor setting for brightness measurement calibration
- Light time delay can be set using parameters, on the device itself or via remote control
- Switch on delay and time delay for presence can be set
- Detection sensitivity can be set
- Reduced time delay in the event of a shorter stay in the room (short presence)
- Scenario functions
- Test mode for checking function and detection range
- Sensitivity adjustable
- Detection area can be limited using cover clip
- Manual override using telegram or remote control
- Parallel switching of several detectors in Master/Slave or Master/Master possible
- Ceiling installation in flush-mounted socket
- Ceiling installation also possible with surface-mounted frame
- User remote control and management-remote control (optional)

### Product selection

Installation type	Colour	Type	Article number
Ceiling installation	White	theRonda P360 KNX UP WH	2089000
	Grey	theRonda P360 KNX UP GR	2089001

### Technical data

	theRonda P360 KNX UP
Operating voltage KNX	Bus voltage, approx. 8 mA (9 mA LED on)
Installation height	2 – 10 m
Setting range brightness	10 – 3000 lx/measuring off
Light switch-off delay	30 s – 60 min
Stand-by dimming value	1 – 25 % of the lamp output
Stand-by time	30 s – 60 min/inactive/permanently on
Presence switch-off delay	10 s – 120 min
Presence switch-on delay	10 s – 30 min/inactive
Ambient temperature	- 15 °C ... +50 °C
Type of protection	IP 54 (when fitted)

Detection range (Round)

Mounting height (A)	Sitting (S)	Walking diagonally (T)	Walking head on to
2 m	16 m <sup>2</sup>   4,5 m	380 m <sup>2</sup>   22 m	28 m <sup>2</sup>   6 m
2,5 m	24 m <sup>2</sup>   5,5 m	415 m <sup>2</sup>   23 m	38 m <sup>2</sup>   7 m
3 m	28 m <sup>2</sup>   6 m	452 m <sup>2</sup>   24 m	50 m <sup>2</sup>   8 m
3,5 m	38 m <sup>2</sup>   7 m	452 m <sup>2</sup>   24 m	50 m <sup>2</sup>   8 m
6 m	-	452 m <sup>2</sup>   24 m	50 m <sup>2</sup>   8 m
10 m	-	491 m <sup>2</sup>   25 m	50 m <sup>2</sup>   8 m

With a mounting height of more than 3.5 m walking motions are necessary and the detection areas of several detectors should overlap in the marginal zone. All figures are up to values. The detection range decreases with increasing temperatures.

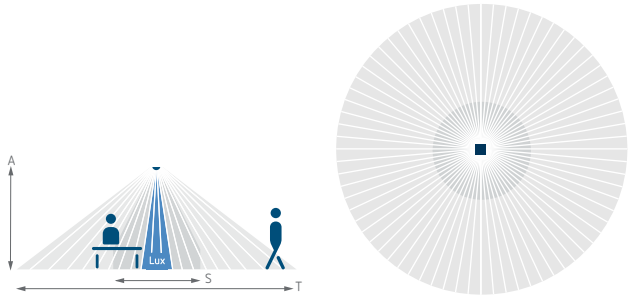

Accessories



Surface frame 110A WH  
↳ Art.No.: 9070912  
Details page 337



theSenda P  
↳ Art.No.: 9070910  
Details page 341



theSenda S  
↳ Art.No.: 9070911  
Details page 341

QuickSafe  
Details page 338

SendoPro 868-A  
Details page 339

Surface frame 110A GR  
Details page 337

Ceiling installation box 73A  
Details page 337

Masking clip  
Details page 337

Scale drawings

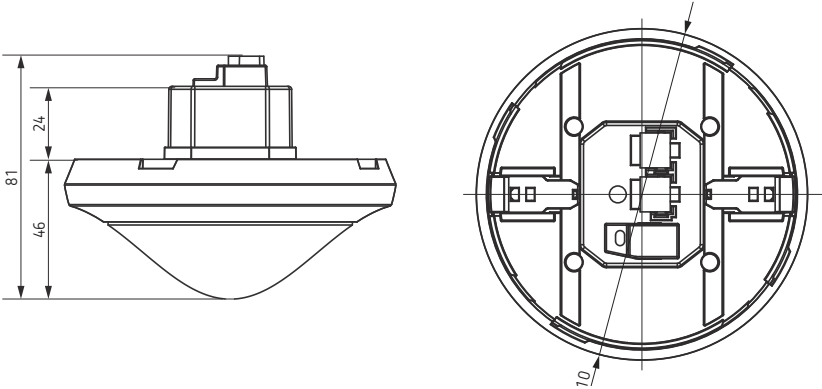

# Home and building control

## KNX, Presence detectors



### Description

#### Common functions

- KNX Passive infrared presence detector for ceiling mounting
- Square detection range of 360° for safe and easy planning
- Mixed light measurement suitable for LEDs, fluorescent lamps (FL/PL/ESL) and halogen/incandescent lamps
- Can be used as fully or semi-automatic, switchable
- Switch or constant light control mode with stand-by function
- Dimmable lighting in switch mode with stand-by function
- Brightness switching value or set point value can be set in lux using parameters, on the device itself or via remote control
- Teaching in of the brightness switching value or the set point value

- Room correction factor setting for brightness measurement calibration
- Light time delay can be set using parameters, on the device itself or via remote control
- Switch on delay and time delay for presence can be set
- Detection sensitivity can be set
- Self-learning time delay
- Reduced time delay in the event of a shorter stay in the room (short presence)
- Scenario functions
- Extremely easy setting of energy saving characteristics with the new „eco plus“ function
- Test mode for checking function and detection range
- Parallel switching of several detectors in Master/Slave or Master/Master possible

- User remote control and management-remote control (optional)
  - Room monitoring
- thePrema P360 KNX UP**
- 3 channels light and 2 channels presence
  - 2 channels light C1, C2 with 2 light measurements and additional lighting channel C3 without brightness factor
  - 2 presence channels can be set individually
  - Adaptable 3 channels light measurement
- thePrema S360 KNX UP**
- 2 channels light and 2 channels presence
  - 2 channels light C1, C2 with 1 light measurement
  - 2 presence channels can be set individually with parallel offset
  - Adaptable 1 channel light measurement

\* According to warranty terms and conditions, see [www.theben.de/en/guarantee](http://www.theben.de/en/guarantee)

### Product selection

Channels	Colour	Type	Article number
3x light / 2x presence	White	thePrema P360 KNX UP WH	2079000
	Grey	thePrema P360 KNX UP GR	2079001
2x light / 2x presence	White	thePrema S360 KNX UP WH	2079500
	Grey	thePrema S360 KNX UP GR	2079501

### Technical data

	thePrema P360 KNX UP	thePrema S360 KNX UP
Operating voltage KNX	Bus voltage, approx. 9 mA (13 mA LED on)	Bus voltage, approx. 8 mA (12 mA LED on)
Installation height	2–10 m	2–3,5 m
Setting range brightness	approx. 5–3000 lx/measuring off	
Light switch-off delay	30 s–60 min	
Stand-by dimming value	1–25 % of the lamp output	
Stand-by time	30 s–60 min/inactive/permanently on	

	thePrema P360 KNX UP	thePrema S360 KNX UP
Presence switch-off delay	10 s – 120 min	
Presence switch-on delay	10 s – 30 min / inactive	
Ambient temperature	0 °C ... +50 °C	
Type of protection	IP 40 (when fitted)	

## Detection range thePrema P360 KNX (Square)

Mounting height (A)	Walking (T)	Sitting (S)
2 m	36 m <sup>2</sup>   6 m x 6 m ± 0,5 m	20 m <sup>2</sup>   4,5 m x 4,5 m
2,5 m	64 m <sup>2</sup>   8 m x 8 m ± 0,5 m	36 m <sup>2</sup>   6 m x 6 m
3 m	81 m <sup>2</sup>   9 m x 9 m ± 1 m	49 m <sup>2</sup>   7 m x 7 m
3,5 m	100 m <sup>2</sup>   10 m x 10 m ± 1 m	64 m <sup>2</sup>   8 m x 8 m
6 m	144 m <sup>2</sup>   12 m x 12 m ± 1,5 m	–
10 m	400 m <sup>2</sup>   20 m x 20 m ± 2 m	–

With a mounting height of more than 3.5 m walking motions are necessary and the detection areas of several detectors should overlap in the marginal zone. All figures are up to values. The detection range decreases with increasing temperatures.

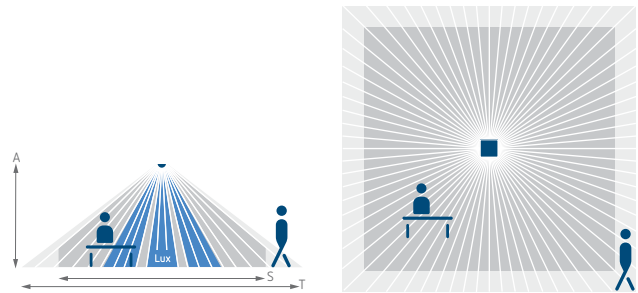

## Detection range thePrema S360 KNX (Square)

Mounting height (A)	Walking (T)	Sitting (S)
2 m	20 m <sup>2</sup>   4 m x 4 m ± 0,5 m	9 m <sup>2</sup>   3 m x 3 m
2,5 m	36 m <sup>2</sup>   6 m x 6 m ± 0,5 m	16 m <sup>2</sup>   4 m x 4 m
3 m	49 m <sup>2</sup>   7 m x 8 m ± 1 m	25 m <sup>2</sup>   5 m x 5 m
3,5 m	64 m <sup>2</sup>   8 m x 8 m ± 1 m	–

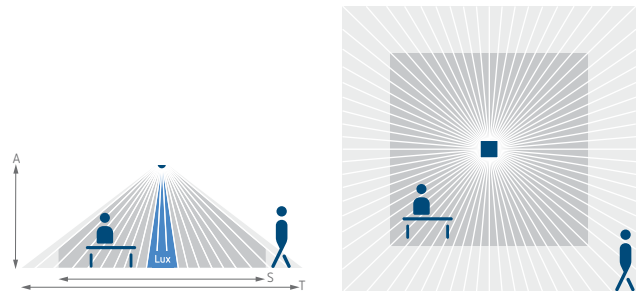

## Accessories



Surface frame 110B WH

↳ Art.No.: 9070918  
Details page 337



theSenda P

↳ Art.No.: 9070910  
Details page 341



theSenda S

↳ Art.No.: 9070911  
Details page 341

QuickSafe

Details page 338

SendoPro 868-A

Details page 339

Ceiling installation box 73A

Details page 337

Surface frame 110B GR

Details page 337

## Scale drawings

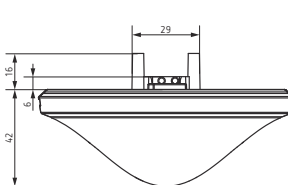

thePrema P360 KNX

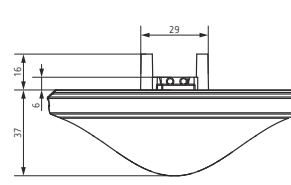
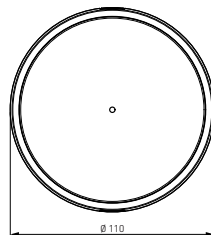

thePrema S360 KNX

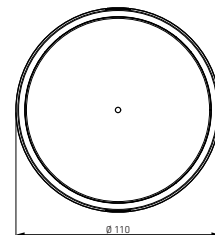



PlanoSpot 360 KNX DE WH

### Description

#### PlanoSpot 360 KNX DE WH

- Passive infrared presence detector for ceiling installation
- Flat design, cover frame in white included in delivery
- Cover frames in black or silver available as optional accessories
- Square detection area 360° (up to 64 m<sup>2</sup>) for reliable and easy planning
- Automatic presence- and brightness-dependent control for lighting and HVAC
- Two differently sized detection zones for greater flexibility. Adjustable via parameters or remote control.
- Manual alignment of the detection area (swivel mechanism)
- Mixed light measurement suitable for fluorescent lamps (FL/PL/ESL), halogen/ incandescent lamps and LEDs
- 3 directed light measurements
- 2 light channels C1, C2 with 2 light measurements and additional lighting channel C3 without brightness factor
- Switched or constant light control with 2 independent control systems and standby function (orientation light)
- Switching mode with dimmable lighting
- Fully or semi-automatic
- Brightness switching value or set point value can be set in lux by using parameters, the object or via remote control
- Teach-in of the brightness switching value or the set point value
- Light time delay configurable
- Self-learning time delay can be set using parameters, object or via remote control
- Reduction of time delay when present briefly (short-term presence)
- Manual override by telegram or remote control
- 2 presence channels C4, C5, individually configurable
- Switch-on delay and time delay configurable
- Room monitoring with selective movement detection
- Setting the room correction factor for brightness measurement comparison
- Configurable sensitivity
- Extremely simple setting of the energy-saving ratio with the new «eco plus» function
- Test mode for checking function and detection area
- Scenarios
- Parallel switching of multiple presence detectors (Master/Slave or Master/Master)
- Installation in false ceilings with springs
- Surface mounting on ceilings possible with surface frame (optional)
- User remote control «theSenda S» (optional)
- Management remote control «SendoPro» (optional)
- Installation remote control «theSenda P» (optional)

#### PlanoSpot 360 KNX S DE WH

As PlanoSpot 360 KNX DE WH, but:

- Without manual alignment of the detection area (swivel mechanism)

### Product selection

Swivel mechanism	Colour	Type	Article number
✓	Pure white (similar to RAL 9010)	PlanoSpot 360 KNX DE WH	2039100
—	Pure white (similar to RAL 9010)	PlanoSpot 360 KNX S DE WH	2039300

### Technical data

	PlanoSpot 360 KNX DE
Operating voltage KNX	Bus voltage, approx. 8 mA (9 mA LED on)
Installation height	2–3,5 m
Setting range brightness	approx. 10–3000 lx/measuring off
Light switch-off delay	30 s–60 min
Stand-by dimming value	1–25 % of the lamp output
Stand-by time	30 s–60 min/on/inactive
Presence switch-off delay	10 s–120 min
Presence switch-on delay	10 s–30 min/inactive
Ambient temperature	0 °C ... +50 °C
Type of protection	IP 40 (when fitted)

Detection range (Square)

Detection zone standard		
Mounting height (A)	Sitting (S)	Walking (T)
2 m	9 m <sup>2</sup>   3 m x 3 m	20 m <sup>2</sup>   4,5 m x 4,5 m ± 0,5 m
2,5 m	16 m <sup>2</sup>   4 m x 4 m	36 m <sup>2</sup>   6 m x 6 m ± 0,5 m
3 m	20 m <sup>2</sup>   4,5 m x 4,5 m	49 m <sup>2</sup>   7 m x 7 m ± 1 m
3,5 m	-	64 m <sup>2</sup>   8 m x 8 m ± 1 m

Detection zone reduced		
Mounting height (A)	Sitting (S)	Walking (T)
2 m	4 m <sup>2</sup>   2 m x 2 m	4,4 m <sup>2</sup>   2,1 m x 2,1 m ± 0,5 m
2,5 m	6,3 m <sup>2</sup>   2,5 m x 2,5 m	9 m <sup>2</sup>   3 m x 3 m ± 0,5 m
3 m	9 m <sup>2</sup>   3 m x 3 m	14,4 m <sup>2</sup>   3,8 m x 3,8 m ± 1 m
3,5 m	-	22,1 m <sup>2</sup>   4,7 m x 4,7 m ± 1 m

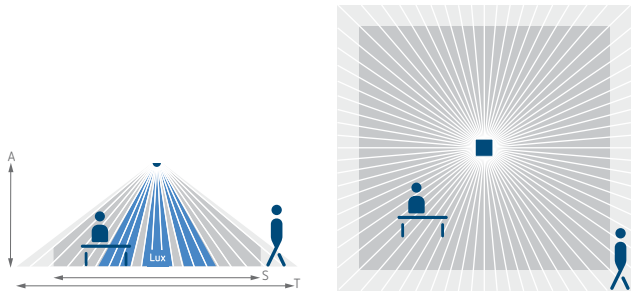

Accessories



Surface frame 75A WH  
↳ Art.No.: 9070949  
Details page 337



theSenda P  
↳ Art.No.: 9070910  
Details page 341



theSenda S  
↳ Art.No.: 9070911  
Details page 341

SendoPro 868-A  
Details page 339

Surface frame 75A BK  
Details page 337

Surface frame 75A SR  
Details page 337

PlanoCover 76 BK  
Details page 338

PlanoCover 76 SR  
Details page 338

Scale drawings

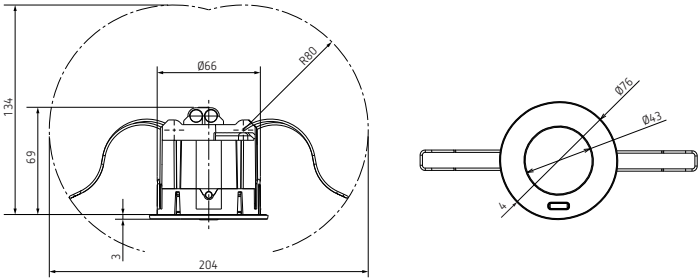

# Home and building control

## KNX, Presence detectors



### Description

- Presence detector (PIR)
- Automatic control of lighting depending on presence and brightness
- Flat design, cover frame in white included in delivery
- Cover frames in black or silver available as optional accessories
- Square detection area allows accurate and simple planning
- Integrated bus coupling unit
- 2 channels light for controlling one or two lighting groups
- Mixed light measurement, suitable for fluorescent lamps (FL/PL/ESL), halogen/ incandescent lamps and LEDs
- Switching or constant light control with stand-by function
- Adjustable sensitivity
- Choice of fully or semi automatic operation: In „Semi-automatic“ mode the light must be switched on manually and switches off automatically
- The self-learning switch-off delay time adjusts to occupants' behavior
- Short presence; Reduced switch-off delay time in case of a short presence
- Channel presence with switch-off delay and switch-on delay time and send values
- Function „monitoring“ with reduced sensitivity only to detect walking persons
- Selected parameters can be configured remotely using the SendoPro remote control. Parameter settings are made via ETS
- Optional user remote control
- Test operation to check detection area, installation and brightness settings
- Parallel switching of several presence detectors (master-slave or master-master) possible
- Individual covers available on request

#### PlanoCentro EWH-A KNX

- For ceiling installation (false ceilings)
- With installation for false ceilings and cover

#### PlanoCentro UWH-A KNX

- For flush-mounting (concrete ceiling)
- With metal installation frame for screwed fixing in wooden ceilings or in flush-mounted sockets, incl. cover

### Product selection

Installation type	Colour	Type	Article number
Ceiling mounting with mounting frame	Pure white (similar to RAL 9010)	PlanoCentro EWH-A KNX	2059102
Ceiling installation (flush-mounting concrete)	Pure white (similar to RAL 9010)	PlanoCentro UWH-A KNX	2059202

### Technical data

	PlanoCentro KNX
Operating voltage KNX	Bus voltage, approx. 14 mA (18 mA LED on)
Installation height	2–3,5 m
Setting range brightness	approx. 5–2000 lx/measuring off
Light switch-off delay	30 s–60 min
Stand-by dimming value	5–10 %
Stand-by time	30 s–60 min/on
Presence switch-off delay	10 s–120 min
Presence switch-on delay	10 s–30 min/inactive
Ambient temperature	0 °C ... +50 °C
Type of protection	IP 40 (when fitted)

Detection range (Square)

Mounting height (A)	Walking (T)	Sitting (S)
2 m	36 m <sup>2</sup>   6 m x 6 m ± 0,5 m	20 m <sup>2</sup>   4,5 m x 4,5 m
2,5 m	64 m <sup>2</sup>   8 m x 8 m ± 0,5 m	36 m <sup>2</sup>   6 m x 6 m
3 m	81 m <sup>2</sup>   9 m x 9 m ± 1 m	49 m <sup>2</sup>   7 m x 7 m
3,5 m	100 m <sup>2</sup>   10 m x 10 m ± 1 m	64 m <sup>2</sup>   8 m x 8 m

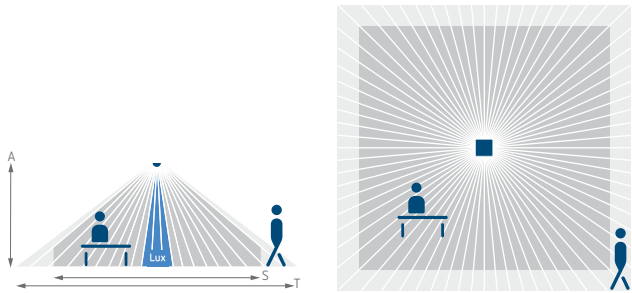

Accessories



**PlanoSets**  
for PlanoCentro-E  
↳ Art.No.: 9070736  
Details page 338



**theSenda S**  
↳ Art.No.: 9070911  
Details page 341



**SendoPro 868-A**  
↳ Art.No.: 9070675  
Details page 339

**theSenda P**  
Details page 341  
**Junction casing,**  
115 x 115 x 100 mm  
for PlanoCentro U  
Details page 338

**PlanoBox**  
for PlanoCentro U  
Details page 338

**QuickSafe**  
Details page 338

**PlanoCover 112 x 112**  
for PlanoCentro E  
Details page 338

**PlanoCover 123 x 123**  
for PlanoCentro U  
Details page 338

Scale drawings

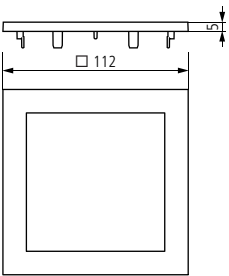

PlanoCentro E KNX

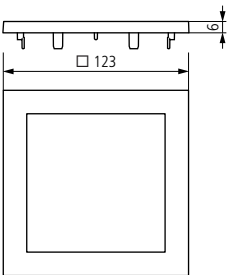
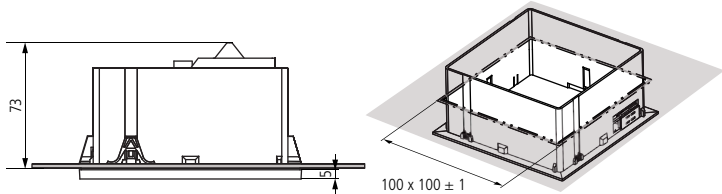

PlanoCentro U KNX

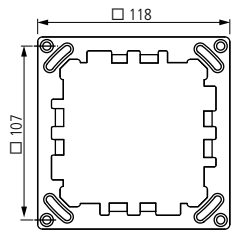
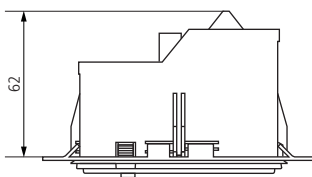
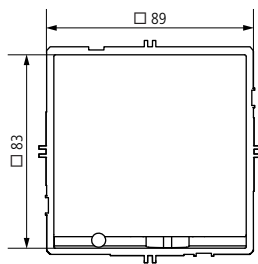

# Home and building control

## KNX, Presence detectors



### Description

- Presence detector (PIR)
- Automatic control of lighting depending on presence and brightness
- Cover frame in white included in delivery, cover frames in black or silver available as optional accessories
- Integrated bus coupling unit
- IP 54 for versatile use
- 2 channels light for controlling one or two lighting groups
- Mixed light measurement, suitable for fluorescent lamps (FL/PL/ESL), halogen/ incandescent lamps and LEDs
- Switching or constant light control with stand-by function
- Adjustable sensitivity
- Choice of fully or semi automatic operation: In „Semi-automatic“ mode the light must be switched on manually and switches off automatically
- Short presence; Reduced switch-off delay time in case of a short presence
- Channel presence with switch-off delay and switch-on delay time and send values
- Function „monitoring“ with reduced sensitivity only to detect walking persons
- Channel brightness (Lux)
- Set brightness level via bus object
- Scene functionality (8-bit scenes)
- Selected parameters can be configured remotely using the SendoPro remote control. Parameter settings are made via ETS
- Optional user remote control
- Ready for use by ex-factory set items
- Test operation to check detection area and installation
- Parallel switching of several presence detectors (master-slave or master-master) possible
- Ceiling mounting in flush-mounted box
- Possibility of surface mounting by using a surface frame

### Product selection

Installation type	Colour	Type	Article number
Wall installation	Pure white (similar to RAL 9010)	PresenceLight 180B-KNX WH	2009050

### Technical data

	PresenceLight 180B-KNX
Operating voltage KNX	Bus voltage, approx. 13 mA (17 mA LED on)
Installation height	1,7–2,2 m
Setting range brightness	approx. 5–2000 lx/measuring off
Light switch-off delay	30 s–60 min
Stand-by dimming value	5–10 %
Stand-by time	30 s–60 min / on/inactive
Presence switch-off delay	10 s–120 min
Presence switch-on delay	10 s–30 min/inactive
Ambient temperature	–10 °C ... +50 °C
Type of protection	IP 54

### Detection range (Semicircular)

Mounting height (A)	Walking (T)	Sitting (S)
2,2 m	100 m <sup>2</sup>   8 m	25 m <sup>2</sup>   7 m x 3,5 m

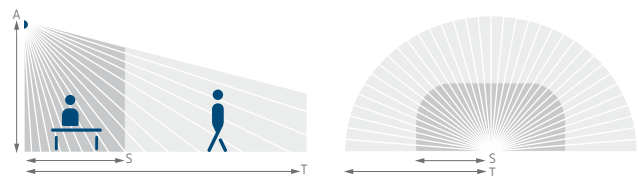

Accessories



Surface frame PresenceLight  
↳ Art.No.: 9070513  
Details page 336



SendoPro 868-A  
↳ Art.No.: 9070675  
Details page 339



QuickSafe  
↳ Art.No.: 9070531  
Details page 338



theSenda P  
↳ Art.No.: 9070910  
Details page 341



theSenda S  
↳ Art.No.: 9070911  
Details page 341

Cover frame PresenceLight 180 SR  
Details page 337

Cover frame PresenceLight 180 BK  
Details page 337

Surface frame PresenceLight BK  
Details page 336

Surface frame PresenceLight SR  
Details page 336

Scale drawings

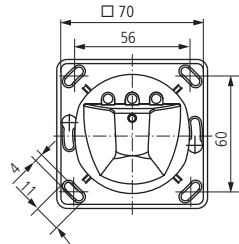
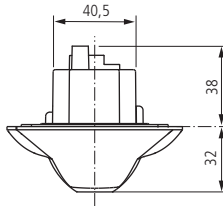
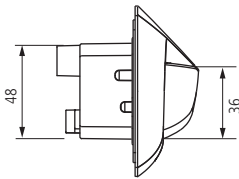
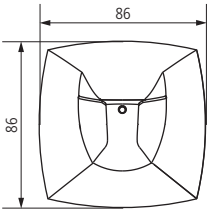

# Home and building control

## KNX, Motion detectors



### Description

- Motion detector (PIR)
- Automatic lighting control based on presence and brightness
- For integration into KNX building systems
- For outdoor use
- For installation on walls and ceilings
- Integrated temperature sensor
- For larger, commercial outdoor applications such as offices, public buildings, hotels, schools, car parks and warehouses
- Easy to program with KNX ETS software
- Adjustable brightness switching value and switch-off delay
- Sensitivity can be reduced
- Area limit via lens attachment
- Mixed light measurement
- Teach-in of current brightness value possible
- Pulse function
- Test function for checking detection area
- Installation on flush-mounted socket possible (60 mm)
- Single-handed plug-in installation
- Instant start-up possible via factory preset
- Controls are place protected
- Spacer and corner angle included

### Product selection

Installation type	Colour	Type	Article number
Wall and ceiling installation	White	theLuxa P300 KNX WH	1019610
	Black	theLuxa P300 KNX BK	1019611

### Technical data

	theLuxa P300 KNX
Operating voltage KNX	Bus voltage, < 10 mA
Setting range brightness	1 – 3000 lx
Light switch-off delay	1 s – 60 min
Ambient temperature	-25 °C ... +45 °C
Protection class	III
Type of protection	IP 55

### Detection range

Mounting height	Head on to	Diagonally
2 m	4 m	12 m
2,5 m	5 m	16 m
3 m	5 m	16 m
3,5 m	5 m	16 m
4 m	4 m	12 m

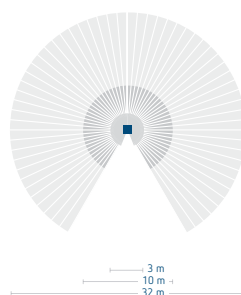

- Walking diagonally to the detector
  - Walking head on to the detector
  - Creep under protection
- Mounting height: 2,5 m

Accessories



Corner angle theLuxa P WH  
↳ Art.No.: 9070904  
Details page 340



Corner angle theLuxa P BK  
↳ Art.No.: 9070905  
Details page 340



theSenda P  
↳ Art.No.: 9070910  
Details page 341



Spacer theLuxa P WH  
↳ Art.No.: 9070908  
Details page 339



Spacer theLuxa P BK  
↳ Art.No.: 9070909  
Details page 339



theSenda S  
↳ Art.No.: 9070911  
Details page 341

Scale drawings

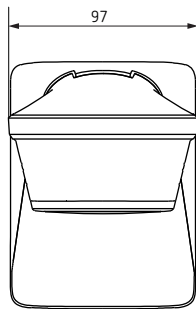
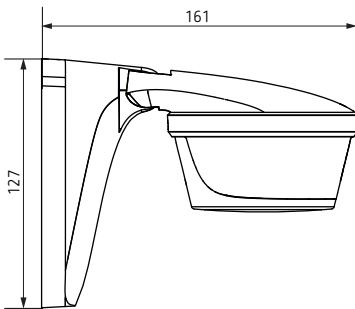

# Home and building control

## KNX, Weather station, brightness sensor

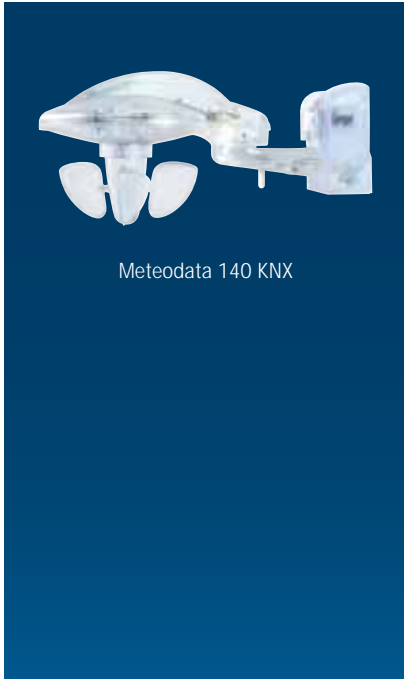

### Description

#### Meteodata 140 S KNX

- Self-contained outdoor weather station
- For measuring wind, rain, brightness and temperature
- For fully automatic blinds and sun protection control with automatic adjustment of blinds according to position of the sun
- Rain sensor with integrated heating
- The weather station can also be operated without mains supply. The heating of the rain sensor will not function then
- Measurement and evaluation directly on device
- Sun protection for up to eight facades via 3 integrated brightness sensors
- 8 sun protection channels
- 4 additional threshold channels for connection of external KNX sensors
- 6 logic channels
- Display of weather data e.g. with VARIA 826 KNX multi-function display

#### Meteodata 140 S GPS KNX

As Meteodata 140 S KNX, but

- Integrated GPS receiver (provides additionally time information)
- Automatic calculation of elevation and azimuth
- The weather station can also be operated without mains supply. The GPS module will not function then

#### Meteodata 140 basic KNX

As Meteodata 140 S KNX, but:

- Without rain sensor
- No automatic adjustment of blinds according to position of the sun
- 3 sun protection channels

### Product selection

Detection	GPS module integrated	Operating voltage	Type	Article number
Wind, Rain, Brightness, Temperature	-	110–230 V AC	Meteodata 140 S KNX	1409207
Wind, Brightness, Temperature	-	-	Meteodata 140 basic KNX	1409205
Wind, Rain, Brightness, Temperature, Time	✓	110–230 V AC	Meteodata 140 S GPS KNX	1409208
Wind, Rain, Brightness, Temperature	-	15–34 V DC	Meteodata 140 S 24V KNX	1409201
Wind, Rain, Brightness, Temperature, Time	✓	15–34 V DC	Meteodata 140 S 24V GPS KNX	1409204

### Technical data

	Meteodata 140 S GPS KNX	Meteodata 140 S KNX	Meteodata 140 S 24V GPS KNX	Meteodata 140 S 24V KNX	Meteodata 140 basic KNX
Operating voltage	110–230 V AC		15–34 V DC		-
Frequency	50–60 Hz		-		
Operating voltage KNX	Bus voltage, ≤ 10 mA				
Stand-by consumption	< 0,5 W				
Measuring range brightness	1–100000 lx				
Measuring range temperature	-30 °C ... +60 °C				
Measuring range wind speed	2–30 m/s				
Ambient temperature	-20 °C ... +55 °C				
Protection class	II		III		II
Type of protection	IP 44				

## Accessories



Mast mounting S  
↳ Art.No.: 9070928  
Details page 345



Power unit 24 V DC  
for Meteodata 140 KNX  
↳ Art.No.: 9079330  
Details page 345

## Scale drawings

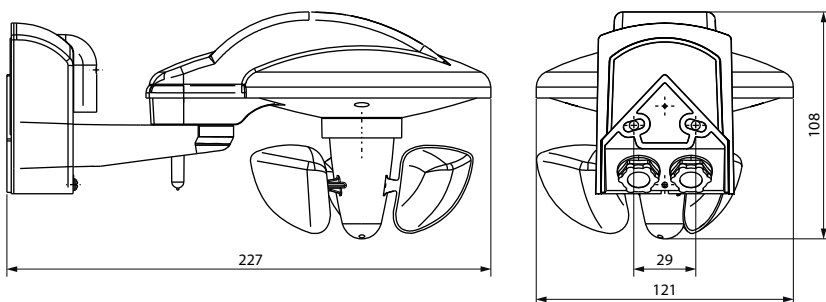

Meteodata 140 KNX

## Connection diagrams

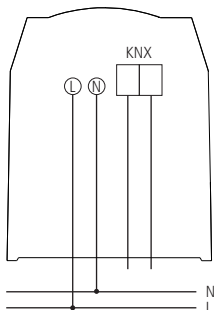

# Home and building control

## KNX, Weather station, brightness sensor



### Description

- Weather forecast receiver
- Receives weather data from the HKW via longwave on hours of sunlight, probability of rain, wind speeds and temperatures
- (This service is not available in all European countries. Find out more at [www.efr.de/en](http://www.efr.de/en))
- Weather forecasts for the next 3 days are shown in 6 hour blocks
- In addition, weather scenarios such as „fine“, „cloudy“, „rainy“, among others, and storm warnings are also received
- Data can be visualised purely for information purposes
- By using the data, heating and shade can be controlled with foresight
- Exact time entry in the KNX system thanks to a time signal sent with the weather data
- Provision and transmission of the weather data by HKW is currently guaranteed until 2021-12-31. Any termination of the transmission will be announced on the website, at least 5 years in advance

### Product selection

Type	Article number
Metodata 139 KNX	1399200

### Technical data

Metodata 139 KNX			
Operating voltage KNX	Bus voltage, $\leq 12$ mA	Protection class	III
Ambient temperature	-20 °C ... +55 °C	Type of protection	IP 54

### Accessories



Mast mounting S  
 ↳ Art.No.: 9070928  
 Details page 345

### Scale drawings

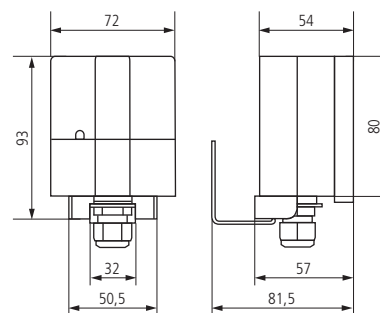

Metodata 139 KNX



### Description

- Light level controller
- External light sensor included in delivery
- For brightness-dependent controlling
- 10 channels
- 4 threshold values channels for connecting external KNX-sensors (e.g. temperature)
- 6 logic channels
- Up to 3 lights sensors can be connected
- Manual operation on device
- 4 keys for setting threshold and switch on/off delay
- DuoFix spring terminals
- Display back light (can be turned off)
- Thresholds can be shown or changed on display
- PIN coding

### Product selection

Type	Article number
LUNA 134 KNX	1349200

### Technical data

LUNA 134 KNX			
Operating voltage	110–240 V AC	Width	3 modules
Frequency	50–60 Hz	Ambient temperature	-5 °C ... +45 °C
Operating voltage KNX	Bus voltage, ≤10 mA	Ambient temperature sensor	-40 °C ... +70 °C
Stand-by consumption	0,8 W	Protection class	II
Measuring range brightness	1–100000 lx	Type of protection	IP 20
On/off switching delay	0–20 min		

### Accessories



Digital surface-mounted light sensor

↳ Art.No.: 9070415

Details page 342



Digital flush-mounted light sensor

↳ Art.No.: 9070456

Details page 342

# Home and building control

## KNX, Weather station, brightness sensor



### Description

- Brightness and temperature sensor
- For brightness and temperature dependent controlling in outdoor areas
- 5 freely configurable channels: 1 sun protection channel and 4 universal channels
- Sun protection channel with automated sun protection especially for blind, awning and shutter applications
- Universal channels allow linking of brightness and temperature
- Brightness range from 1 - 100,000 lux
- Temperature range -20 °C to + 55 °C
- Learning object for brightness threshold

### Product selection

Type	Article number
LUNA 131 S KNX	1319201

### Technical data

LUNA 131 S KNX			
Operating voltage KNX	Bus voltage, ≤5 mA	Ambient temperature	-25 °C ... +55 °C
Measuring range brightness	1 – 100000 lx	Type of protection	IP 54
Measuring range temperature	-20 °C ... +55 °C		

### Accessories



Mast mounting S  
 ↳ Art.No.: 9070928  
 Details page 345

### Scale drawings

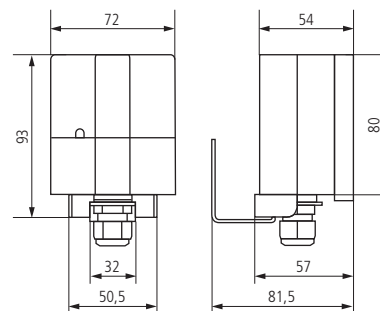

LUNA 131 S KNX



LUNA 133 KNX

## Description

- Brightness sensor
- For brightness dependent controlling in outdoor areas
- Brightness range from 1 - 100,000 lux
- Ideally combinable with the Theben weather stations for individual control of several facades

## Product selection

Type	Article number
LUNA 133 KNX	1339200

## Technical data

LUNA 133 KNX			
Operating voltage KNX	Bus voltage, $\leq 5$ mA	Ambient temperature	-25 °C ... +55 °C
Measuring range brightness	1 – 100000 lx	Type of protection	IP 54

## Accessories



Mast mounting S  
↳ Art.No.: 9070928  
Details page 345

## Scale drawings

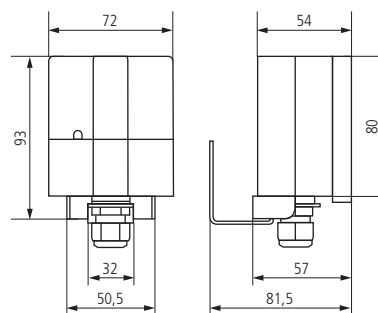

LUNA 133 KNX

# Home and building control

## KNX, Digital time switches



TR 648 top2 RC KNX

TR 648 top2 RC-DCF KNX

### Description

#### Common functions

- Digital time switch with yearly and astronomical time program
- 8 channels
- DuoFix spring terminals for 2 conductors each
- Text-oriented user guidance in display
- 800 memory locations
- Interface for OBELISK top2 memory card (PC programming)
- 8 year power reserve (lithium battery)
- ON-OFF switching times
- Pulse program
- Cycle program
- Extensive yearly clock functions

- Astronomical switching function (automatic calculation of sunrise and sunset times for the whole year)
- Switching preselection
- Permanent switching ON/OFF
- Count-down timer
- Integrated hour counter
- Holiday program
- 2 random programs
- Display backlight (can be turned off)
- PIN coding
- Automatic summer/winter time changeover
- Time and date synchronisation of other bus participants

#### TR 648 top2 RC KNX

- Time synchronisation via connection of external DCF or GPS antennas, additional positioning for astronomical program with GPS

#### TR 648 top2 RC-DCF KNX

- Time synchronisation via connection of external DCF antenna
- Can be operated without mains supply

### Product selection

Type	Article number
TR 648 top2 RC KNX	6489212
TR 648 top2 RC-DCF KNX	6489210

Technical data

	TR 648 top2 RC KNX	TR 648 top2 RC-DCF KNX
Operating voltage KNX	Bus voltage, $\leq 12$ mA	
Operating voltage	110–240 V AC	–
Frequency	50–60 Hz	–
Stand-by consumption	0,2 W	–
Width	3 modules	
Number of channels	8	
Number of memory locations	800	
Time accuracy at 25 °C	$\leq \pm 0,5$ s/day (quartz) or DCF77/GPS	$\leq \pm 0,5$ s/day (quartz) or DCF77
Shortest switching times	1 s	
Display	LCD	
Ambient temperature	–5 °C ... +45 °C	
Type of protection	IP 20	
Protection class	II according to EN 60 730-1	III according to EN 60 730-1

Accessories



Antenna top2 RC-GPS  
for TR 648 top2 RC KNX  
↳ Art.No.: 9070610  
Details page 335



Antenna top2 RC-DCF  
↳ Art.No.: 9070410  
Details page 335



PC set OBELISK top2  
↳ Art.No.: 9070409  
Details page 335



Memory card OBELISK top2  
↳ Art.No.: 9070404  
Details page 335

Connection diagrams

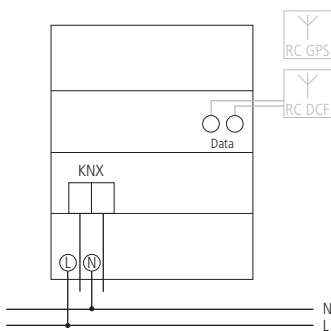

TR 648 top2 RC KNX

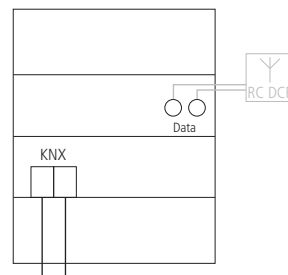

TR 648 top2 RC-DCF KNX

# Home and building control

## KNX, Time transmitter



ZS 600 DCF KNX

### Description

- Time transmitter for hour and date
- Can also be used with DCF77 antenna
- LED for status display DCF reception
- Integrated voltage supply for DCF77 antenna
- Preset time and date (CET or CEST)
- Automatic summer/winter time switchover

### Product selection

Type	Article number
ZS 600 DCF KNX	6009200

### Technical data

ZS 600 DCF KNX			
Operating voltage KNX	Bus voltage, ≤10 mA	Ambient temperature	-10 °C ... +50 °C
Width	2 modules	Protection class	III according to EN 60 730-1
Power reserve	10 years	Type of protection	IP 20
Time accuracy at 25 °C	≤ ± 1 s/day (quartz) or DCF77 synchronous		

### Accessories

#### Antenna DCF77 KNX

↳ Art.No.: 9070271

Details page 335





### Description

- The DALI Gateway KNX serves as an interface between the the DALI and the KNX system
- A maximum of 64 DALI members can be connected to a DALI output
- Individual control of up to 64 ECGs possible
- Up to 16 groups can be switched, dimmed or set to a defined value
- Operation of single battery emergency lamps according to EN 62386-202
- Emergency lighting systems with central battery are also supported
- Support of DALI „Device Type 8“ (DT8) for controlling light color, brightness and color temperature
- Status and error information for a visualization
- Scene module for up to 16 different groups
- Effect module for sequencers
- LC display (2x 12 characters) for menu guidance during start-up and parameter settings
- The DALI start-up takes place via the control elements on the device, via the integrated web server or via the ETS plug-in

### Product selection

Type	Article number
DALI-Gateway KNX plus	9070929

### Technical data

DALI-Gateway KNX plus			
Operating voltage KNX	Bus voltage, <10 mA	Ambient temperature	-5 °C ... +45 °C
Operating voltage	100 – 240 V AC/DC	Protection class	I
Frequency	50 – 60 Hz	Type of protection	IP 20
Width	4 modules		



KNX-OT-Box S

### Description

- The KNT-OT-Box S serves as an interface between the boilers with OpenTherm (bus system in heating and ventilation technology) and the KNX system (building system technology)
- This enables the bidirectional exchange of data between the OpenTherm boiler and the heat distribution via the KNX system (individual room control)
- In combination with the OT-Box (9070712) from the RAMSES 856 top2 OT (8569132) also heating systems without OpenTherm interface can be controlled
- Device and KNX bus module can be swapped independently of each other
- Removable KNX bus module
- Button for OT-test-program
- The following functions are available with the KNT- OT-box:
  - Customised flow control
  - Weather-compensation flow control
  - Control of domestic hot water
  - Energy optimization of domestic hot water with solar support
  - Legionella protection program
  - Screed drying program

### Product selection

Type	Article number
KNX-OT-Box S	8559201

### Technical data

KNX-OT-Box S			
Operating voltage KNX	Bus voltage, ≤10 mA	Ambient temperature	+0 °C ... +45 °C
Width	4 modules	Protection class	III
Rated impulse with stand voltage	4 kV	Type of protection	IP 20

### Connection diagrams

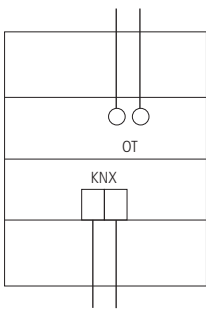

KNX-OT-Box S

12

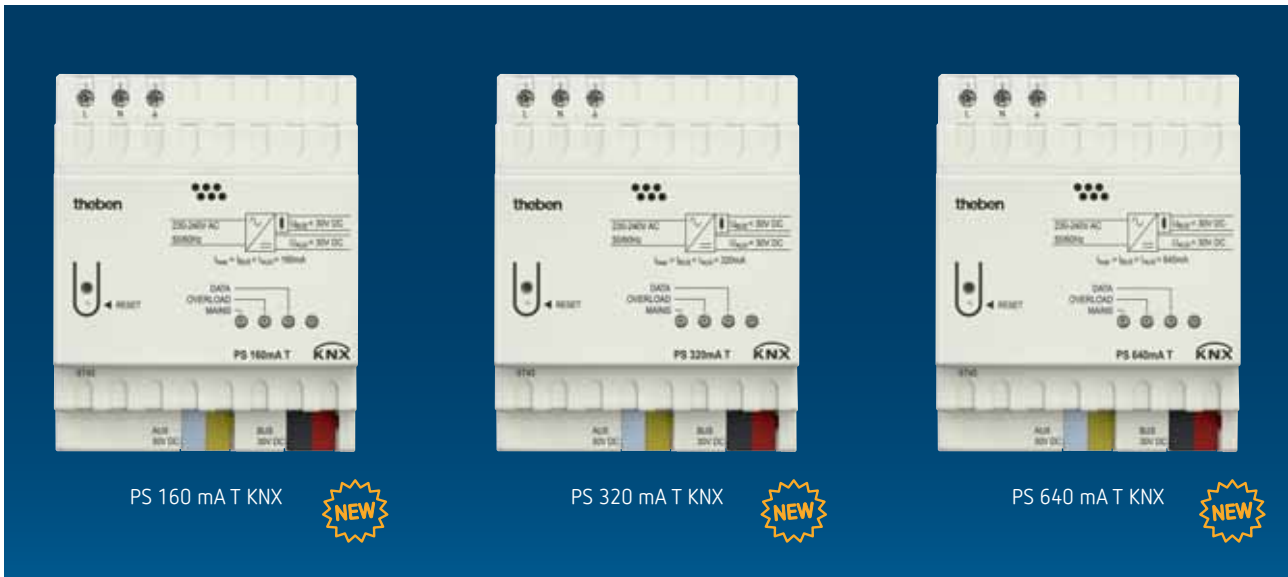

## Description

### Common functions

- 30 V DC auxiliary supply
- Power-supplying and monitoring of the KNX system voltage
- Reset key for 20 sec. bus reset
- Continuous short-circuit protection

### PS 160 mA T KNX

- 160 mA supply voltage

### PS 320 mA T KNX

- 320 mA supply voltage

### PS 640 mA T KNX

- 640 mA supply voltage

## Product selection

Type	Article number
PS 160 mA T KNX	9070956
PS 320 mA T KNX	9070957
PS 640 mA T KNX	9070958

## Technical data

	PS 160 mA T KNX	PS 320 mA T KNX	PS 640 mA T KNX
Operating voltage KNX	Bus voltage, $\leq 12$ mA		
Operating voltage	230–240 V AC		
Frequency	50–60 Hz		
Stand-by consumption	$\leq 0,8$ W		
Width	4 modules		
KNX output	1 line with integrated throttle drive		
Nominal voltage KNX	30 V DC, $\pm 2$ V, SELV		
Nominal current KNX	160 mA	320 mA	640 mA
Uninterrupted short-circuit current	max.0,5 A	max.0,8 A	max.1,4 A
Mains failure bridging time	min.130 ms		
Ambient temperature	$-5$ °C ... $+45$ °C		
Protection class	II according to EN 60 730-1		
Type of protection	IP 20		



## Description

### Common functions

- Firmware update (Theben IP Tool Software)
- Power Supply: 12–30 V DC/PoE - IEEE 802.3af class 1

### IP Interface KNX

- Interface IP and KNX
- Tunneling: Up to 5 Tunneling Server

### IP Router KNX

- Router/Interface/Line Coupler IP and KNX
- Support of full Filter Table for all main groups 0...31
- Monitoring for KNX bus voltage failure (KNX IP Service)
- Unicast: Up to 10 unicast devices

- Tunneling: Up to 5 Tunneling Server (Visualisation, App...)

## Product selection

Type	Article number
IP Interface KNX	9070981
IP Router KNX	9070980

## Technical data

	IP Interface KNX	IP Router KNX
Operating voltage KNX	Bus voltage, ≤10 mA	
Operating voltage	12–30 V DC	
Width	2 modules	
Ambient temperature	-5 °C ... +45 °C	
Protection class	II according to EN 60 730-1	
Type of protection	IP 20	



Interface USB KNX

Line coupler S KNX

## Description

### Interface USB KNX

- USB interface
- For communication between PC and the KNX equipment to be programmed
- USB LED and KNX LED to display data transmission
- Usable from ETS3

### Line coupler S KNX

- Line coupler
- For connecting KNX lines or areas
- Galvanic separation of the lines/areas
- Bus terminals for main line and subordinate line

- Telegrams can be filtered (to reduce telegram traffic)
- Can also be used as line amplifier (repeater)

## Product selection

Type	Article number
Interface USB KNX	9070397
Line coupler S KNX	9070880

## Technical data

	Interface USB KNX	Line coupler S KNX
Operating voltage KNX	Bus voltage, ≤10 mA	
Operating voltage	-	24 V DC
Width	2 modules	
Ambient temperature	-5 °C ... +45 °C	
Protection class	II according to EN 60 730-1	III
Type of protection	IP 20	



OSIRIA 220/230/240 AR KNX

OSIRIA 230 SR KNX, OSIRIA 240 SR KNX

OSIRIA 241 BR KNX, OSIRIA 241 AR KNX

## Description

OSIRIA 220 AR KNX, OSIRIA 230 AR KNX, OSIRIA 240 AR KNX

- KNX indoor clock, round, single-sided
- Black bar hour and minute hands, red second hand
- White metallic dial with black arabic numerals
- Impact-resistant plastic housing
- Matte border
- Flat, shock-resistant Plexiglas
- Diameter dial: 250 mm/300 mm/400 mm

OSIRIA 230 SR KNX, OSIRIA 240 SR KNX

- KNX indoor clock, round, single-sided
- Black bar hour and minute hands, red second hand
- White metallic dial with black fine-line numerals
- Impact-resistant plastic housing
- Matte border
- Flat, shock-resistant Plexiglas
- Diameter dial: 300 mm/400 mm

OSIRIA 241 BR KNX, OSIRIA 241 AR KNX

- KNX indoor clock, round, single-sided
- Silver metallic painted metallic housing (RAL 9006 white-aluminium)
- Black bar hour and minute hands, red second hand
- White metallic dial with black DIN bar numerals or arabic numbers
- Curved, shock-resistant Plexiglas
- Diameter dial: 400 mm

## Product selection

Dial dimensions	Housing material	Type of numerals	Type	Article number
∅ 250 mm	Plastic housing	Arabic numerals	OSIRIA 220 AR KNX	5009200
∅ 300 mm	Plastic housing	Arabic numerals	OSIRIA 230 AR KNX	5009210
		Fineline numerals	OSIRIA 230 SR KNX	5009211
∅ 400 mm	Plastic housing	Arabic numerals	OSIRIA 240 AR KNX	5009230
		Fineline numerals	OSIRIA 240 SR KNX	5009231
	Silver metallic painted metallic housing	Arabic numerals	OSIRIA 241 AR KNX	5009240
		Bar numerals	OSIRIA 241 BR KNX	5009241



## Description

### OSIRIA 242 AR KNX, OSIRIA 242 SR KNX

- KNX indoor clock, round, double-sided
- With wall or ceiling holder (150 mm)
- White dials
- Black Arabic numerals
- Black bar hour and minute hands, red second hand
- White painted metallic housing
- Shock-resistant plexiglass
- Diameter dial: 400 mm

### OSIRIA 251 BQ KNX

- KNX indoor clock, square, single-sided
- Wall clock limited protected against thrown balls e.g. for sports halls, schools, etc.
- White metallic dial with black DIN bar numerals
- Black bar hour and minute hands, red second hand
- Single-faced, robust, white painted metallic housing (RAL 9016) for heavy-duty applications
- Laminated safety glass
- 3-point fastening resistant to being pried out
- Dial: 400 mm x 400 mm

### OSIRIA 232 BQ KNX

- KNX indoor clock, square, single-sided, for flush-mounted installation (for OP rooms)
- White metallic dial with black DIN bar numerals
- Black bar hour and minute hands, red second hand
- Stainless steel housing frame flush with tiles or wall V4A for wall installation (flush-mounted)
- Resistant to acids, cleaning agents and disinfectants; in the installed state protected against dust and water in acc. with protection rating IP 54 (DIN 40050)
- 3 mm flat mineral lens
- Dial: 250 x 250 mm

## Product selection

Dial dimensions	Housing material	Type of numerals	Type	Article number
Ø 400 mm	White painted metallic housing	Arabic numerals	OSIRIA 242 AR KNX	5009250
		Fineline numerals	OSIRIA 242 SR KNX	5009251
400 mm x 400 mm	White painted metallic housing	Bar numerals	OSIRIA 251 BQ KNX	5009252
250 mm x 250 mm	Rustproof high quality steel housing	Bar numerals	OSIRIA 232 BQ KNX	5009223

# Home and building control

## KNX, visualisation



### Description

- theSera S110 is a high-performance KNX visualisation solution for lighting, awning and climate control via smartphone and tablet
- The intuitive app user interface is able to control devices, and also:
  - Display status and alarm messages and measured values as text or via pre-defined symbols
  - Show energy consumption in graphic format
  - Mix colours of RGB LEDs using a colour wheel
  - Integrate images from IP cameras
  - Control audio/video devices from almost all leading manufacturers via IR transmitter from IRTrans
  - Display current weather data and forecasts from the Internet or via KNX weather stations
  - Program time switch and calendar functions, as well as scenes
- In addition to the functions above, theSera offers a complete range of other functions that run in the background, including:
  - Presence simulation
  - Solar position calculation with sunrise and sunset
  - Logic, multiplexer and filter functions
  - Linear combination
  - Calculation of complex mathematical functions
  - Notification via email and push notifications (iOS only)
  - Load management for automatic shut-down of consumers
- Configuration is via theSera configurator. A theSera S110 miniserver from Theben is required to operate the software. Further information is available from the Theben website at [www.theben.de/en](http://www.theben.de/en)

### Product selection

Type	Article number
theSera S110	8254100

### Technical data

	theSera S110
Operating voltage	110–240 V AC
Frequency	50–60 Hz
Stand-by consumption	< 1 W
Ambient temperature	0 °C ... +50 °C
Type of protection	IP 20

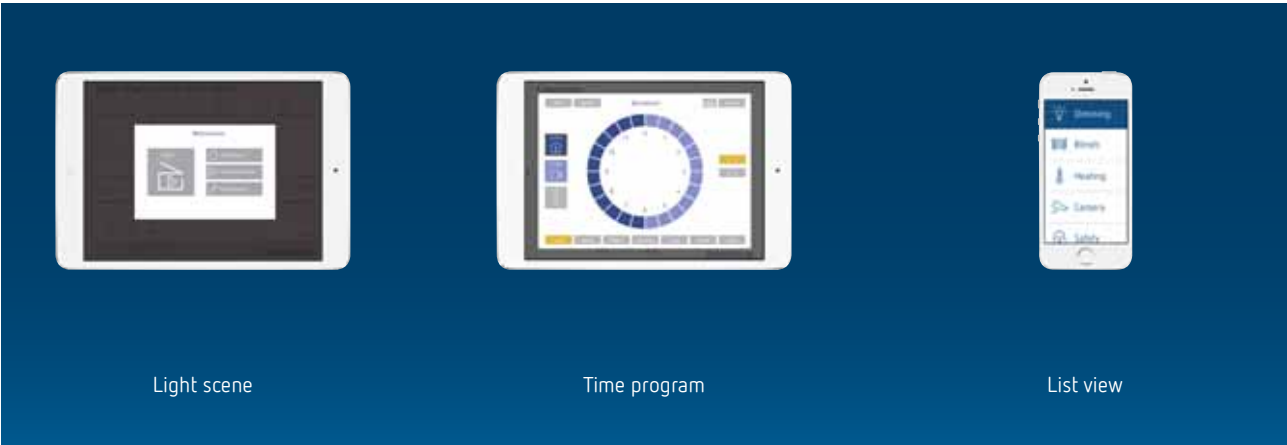

Scale drawings

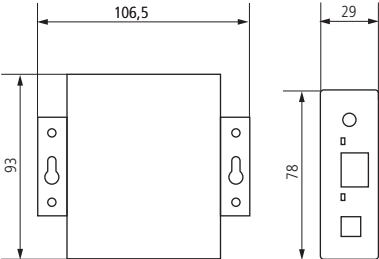

More information















App download



## Open to new perspectives

Sometimes you need to change perspective to discover new possibilities. Then you establish that you're not just going further, but upwards. Theben always takes the viewpoint of its customers. First, to develop products that meet the requirements of people who will use them. Second, to be open to new technologies. So we are, as it were, programmed to change perspective systematically. For us it's a central value: openness.



Description	Type	Page	
<b>LUXORliving Actuators</b>			
 LUXORliving Switching actuators	LUXORliving S4 / LUXORliving S8 / LUXORliving S16	306	
LUXORliving Dimming actuators	LUXORliving D2 / LUXORliving D4	308	
LUXORliving Blinds actuators	LUXORliving J4 / LUXORliving J8	309	
<b>LUXORliving Binary inputs/Push-button interfaces</b>			
 LUXORliving Binary inputs	LUXORliving B6	310	
LUXORliving Push-button interfaces	LUXORliving T2 / LUXORliving T4 / LUXORliving T8	311	
<b>LUXORliving Heating control</b>			
 LUXORliving Room thermostat	LUXORliving R718	313	
LUXORliving Heating actuator	LUXORliving H6	312	
<b>LUXORliving Weather station</b>			
 LUXORliving Weather station	LUXORliving M140	314	
<b>LUXORliving System center</b>			
 LUXORliving System center	LUXORliving IP1	315	
<b>LUXORliving Power supply</b>			
 LUXORliving Power supply	LUXORliving P640	316	
<b>LUXORliving Sets</b>			
	LUXORliving Sets	LUXORliving set drives	317
		LUXORliving set lighting	317
		LUXORliving set lighting&drives	317
<b>LUXOR Switching/Dimming/Blinds control</b>			
	LUXOR Switching	LUXOR 400 / LUXOR 404 / LUXOR 402	318
	LUXOR Dimming	LUXOR 405 S	320
	LUXOR Blinds control	LUXOR 408 S / LUXOR 409 S	321
<b>LUXOR Weather sensors</b>			
	LUXOR Weather sensors	LUXOR 411	322
		LUXOR 440	322
<b>LUXOR Multifunction display</b>			
 LUXOR Multifunction display	LUXOR 426	324	
<b>LUXOR Time switch module</b>			
 LUXOR Time switch module	LUXOR 414	326	
<b>LUXOR Sets</b>			
 LUXOR Sets	LUXOR Set 4 / LUXOR Set 5	327	

# Home and building control







## Smart Home system LUXORliving, Switching actuators



### Smart Home system LUXORliving

- LUXORliving is the simple smart home system from Theben, offering all-round home comfort, whilst avoiding unnecessary waste. Switching lights on and off. Dimming. Regulating heating and controlling blinds.
- That's what it's all about. And the best thing: LUXORliving is so easy to assemble, install and use that you don't need to be a specialised fitter – unless you really want to!
- Anyone who is building or renovating should include LUXORliving in their plans. The smart home system makes houses and flats more comfortable and provides a pleasant working atmosphere in offices and doctor's surgeries too. What's more, it creates optimum conditions for you to use your energy-saving potential.

### Highlights of LUXORliving at a glance

-  Simple start-up
-  Free push button selection
-  Certified KNX system
-  Flexible BUS wiring
-  Safe panic function
-  Control centre OFF
-  Individual scenarios
-  Clever presence simulation

### Description Switching actuators

- |                                                                                                                                                                                                                                                                                                     |                                                                                                                                                                                                                               |                                                                                                                  |
|-----------------------------------------------------------------------------------------------------------------------------------------------------------------------------------------------------------------------------------------------------------------------------------------------------|-------------------------------------------------------------------------------------------------------------------------------------------------------------------------------------------------------------------------------|------------------------------------------------------------------------------------------------------------------|
| <p>Common functions</p> <ul style="list-style-type: none"> <li>- Switching actuator LUXORliving</li> <li>- LED switching status display for each channel</li> <li>- Manual operation on device</li> <li>- Switching functions: On/Off, pulse, On/Off delay, staircase light with warning</li> </ul> | <p>LUXORliving S4</p> <ul style="list-style-type: none"> <li>- 4-way switching actuator LUXORliving</li> </ul> <p>LUXORliving S8</p> <ul style="list-style-type: none"> <li>- 8-way switching actuator LUXORliving</li> </ul> | <p>LUXORliving S16</p> <ul style="list-style-type: none"> <li>- 16-way switching actuator LUXORliving</li> </ul> |
|-----------------------------------------------------------------------------------------------------------------------------------------------------------------------------------------------------------------------------------------------------------------------------------------------------|-------------------------------------------------------------------------------------------------------------------------------------------------------------------------------------------------------------------------------|------------------------------------------------------------------------------------------------------------------|

### Product selection

Number of channels	Type	Article number
4	LUXORliving S4	4800420
8	LUXORliving S8	4800425
16	LUXORliving S16	4800429

### Technical data

	LUXORliving S4	LUXORliving S8	LUXORliving S16
Operating voltage	110–240 V AC		
Frequency	50–60 Hz		
Stand-by consumption	< 0,3 W		
Width	4 modules		8 modules
Type of contact	NO contact, 16 A (cos $\phi$ = 1), 3 A (cos $\phi$ = 0,6)		
Inrush current	max. 800 A / 200 $\mu$ s		
Resistive load	3680 W		
Incandescent lamp load	2000 W		
Fluorescent lamp load (electronic ballast)	1200 W		
Energy saving lamps	300 W		
LED lamp < 2 W	55 W		
LED lamp 2-8 W	180 W		
LED lamp > 8 W	200W		
Operating temperature	-5 °C ... +45 °C		
Type of protection	IP 20		
Protection class	II		

### Connection diagrams

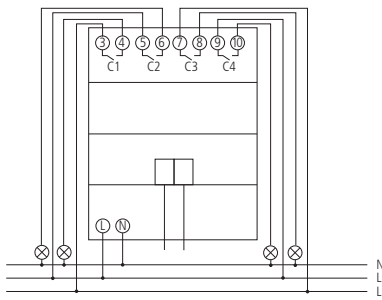

LUXORliving S4

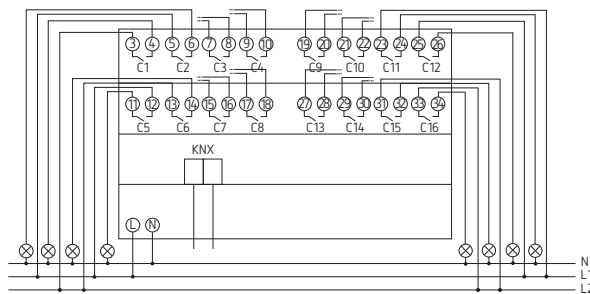

LUXORliving S16

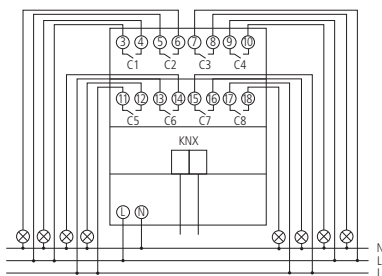

LUXORliving S8

# Home and building control

## Smart Home system LUXORliving, Dimming actuators



### Description

#### Common functions

- Universal dimmer actuator LUXORliving
- For dimming dimmable LED, incandescent lamps, LV, HV halogen lamps and energy saving lamps
- Also suitable for dimming of dimmable energy-saving lamps

- LED switching status display for each channel

- Manual operation on device

#### LUXORliving D2

- 2-way universal dimmer actuator LUXORliving

- Dimming output: 400 W per channel, dimming area 0-100%

#### LUXORliving D4

- 4-way universal dimmer actuator LUXORliving

- Dimming output: 200 W per channel, dimming area 0-100%

### Product selection

Number of channels	Switching capacity per channel	Type	Article number
2	400 W	LUXORliving D2	4800470
4	200 W	LUXORliving D4	4800475

### Technical data

	LUXORliving D2	LUXORliving D4
Operating voltage	230 V AC	
Stand-by consumption	0,9 W	< 1 W
Width	4 modules	
Lamp types	Incandescent, low-voltage and high-voltage halogen and dimmable energy saving lamps and LED	
Switching capacity dimmable energy saving lamps per channel	400 W	200 W
Switching capacity dimmable 230 V LED per channel	400 W	200 W
Incandescent/halogen lamp load	400 W	200 W
Type of protection	IP 20	
Protection class	II according to EN 60 669	

### Connection diagrams

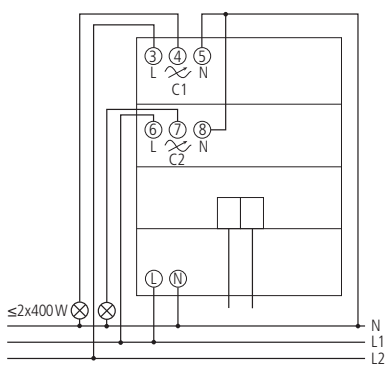

LUXORliving D2

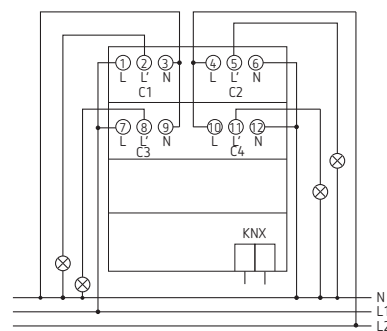

LUXORliving D4



## Description

### Common functions

- Blind actuator LUXORliving
- For controlling drives for blinds, shutters, sun and vision protection devices
- Manual operation on device

- LED Up and Down switching status display for each channel

### LUXORliving J4

- 4-way blind actuator LUXORliving

### LUXORliving J8

- 8-way blind actuator LUXORliving

## Product selection

Number of channels	Type	Article number
4	LUXORliving J4	4800450
8	LUXORliving J8	4800455

## Technical data

	LUXORliving J4	LUXORliving J8
Operating voltage	110–240 V AC	
Stand-by consumption	< 0,3 W	< 0,5 W
Width	4 modules	8 modules
Type of contact	NO contact	
Type of protection	IP 20	
Protection class	II according to EN 60 669	

## Connection diagrams

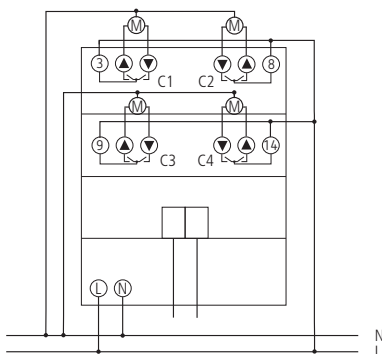

LUXORliving J4

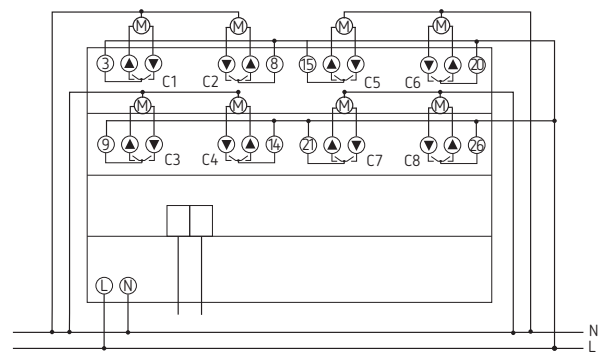

LUXORliving J8

# Home and building control

## Smart Home system LUXORliving, Binary input



### Description

- 6-way binary input LUXORliving
- 6 floating universal and wide-range voltage inputs (10-240 V AC/DC or internally generated auxiliary voltage of approx. 12 V DC)
- Software functions: Switch/push-button, dimming, blinds
- LED switching status display for each channel
- Manual operation on device

### Product selection

Number of channels	Type	Article number
6	LUXORliving B6	4800430

### Technical data

LUXORliving B6			
Operating voltage	110–240 V AC	Type of protection	IP 20
Stand-by consumption	< 0,3 W	Protection class	II according to EN 60 730-1
Width	4 modules		



## Description

### Common functions

- Can be installed in flush-mounted sockets with conventional sensors/switches
- Software functions: Switch/push-button, dimming, blinds
- Colour coding of wiring pairs

### LUXORliving T2

- 2-way binary input sensor interface LUXORliving
- 4-pole cable connection

### LUXORliving T4

- 4-way binary input sensor interface LUXORliving
- 6-pole cable connection

### LUXORliving T8

- 8-way binary input sensor interface LUXORliving
- 10-pole cable connection

## Product selection

Number of channels	Type	Article number
2	LUXORliving T2	4800402
4	LUXORliving T4	4800404
8	LUXORliving T8	4800408

## Technical data

	LUXORliving T2	LUXORliving T4	LUXORliving T8
Interface extension max.		30 m	
Length connecting wires		25 cm	
Contact current		0,5 mA	
Type of protection		IP 20	
Protection class		III	

## Scale drawings

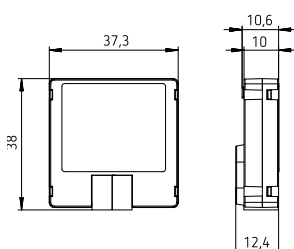

## Connection diagrams

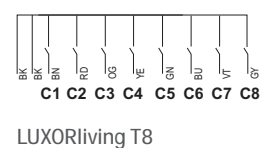
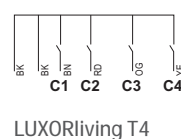
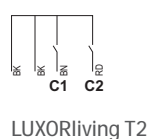

# Home and building control

## Smart Home system LUXORliving, Heating actuator



### Description

- 6-way heating actuator LUXORliving
- For controlling 6 thermal actuators  
24 V–240 V AC in 2 groups with 3 outputs  
and 450 mA each
- Valve protection
- LED switching status display for each  
channel
- Manual operation on device

### Product selection

Number of channels	Type	Article number
6	LUXORliving H6	4800440

### Technical data

LUXORliving H6			
Operating voltage	110–240 V AC	Output	Triac
Stand-by consumption	0,3 W	Type of protection	IP 20
Width	4 modules	Protection class	II according to EN 60 669
Switching output	Not potential-free		

### Connection diagrams

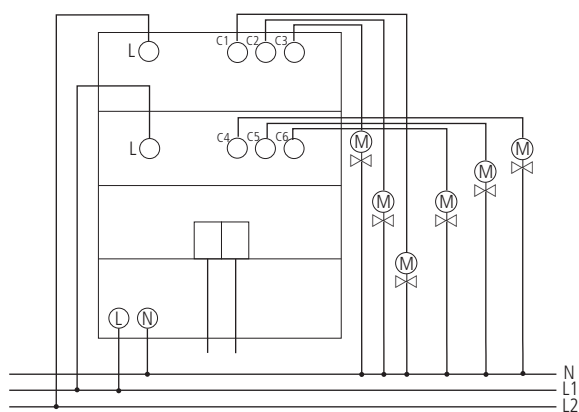

LUXORliving H6



### Description

- Individual room thermostat LUXORliving
- Setting range 5 - 30°C
- Applications: heating via radiator or underfloor heating, heating and cooling e.g. radiator or cooling ceiling
- Integrated 4-way binary input sensor interface

### Product selection

Type	Article number
LUXORliving R718	4800480

### Technical data

LUXORliving R718			
Interface extension max.	5 m	Setting range temperature	+5 °C ... +30 °C
Ambient temperature	+5 °C ... +40 °C	Type of protection	IP 20
Measuring range temperature	-5 °C ... +45 °C	Protection class	III according to EN 60 730-1

### Scale drawings

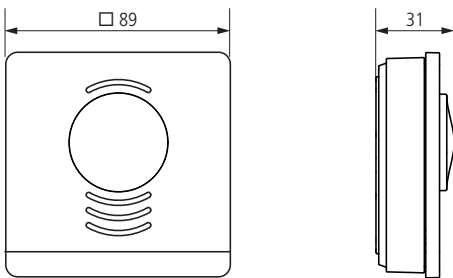

### Connection diagrams

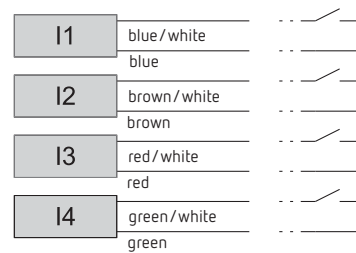

# Home and building control

## Smart Home system LUXORliving, Weather station



### Description

- Self contained outdoor weather station LUXORliving
- For measuring wind, rain, brightness and temperature
- Rain sensor with integrated heating
- For fully automatic blinds and sun protection control
- Measurement and evaluation directly on device
- Sun protection for up to 4 facades via 3 integrated brightness sensors
- Display of weather data e.g. with LUXORliving-App „LUXORplay“

### Product selection

Type	Article number
LUXORliving M140	4800490

### Technical data

LUXORliving M140			
Operating voltage	110–230 V AC	Measuring range temperature	-30 °C... +60 °C
Frequency	50–60 Hz	Measuring range wind speed	2–30 m/s
Operating voltage KNX	Bus voltage, ≤10 mA	Ambient temperature	-20 °C... +55 °C
Stand-by consumption	< 5,5 W	Protection class	II
Measuring range brightness	100000 lx	Type of protection	IP 44

### Scale drawings

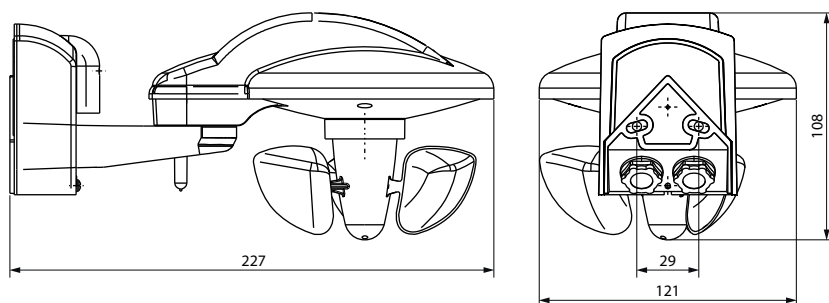

LUXORliving M140



### Description

- System Center LUXORliving
- With Ethernet and bus interface
- For setting-up the LUXORliving system via LUXORplug software
- Storage of project data for visualization via LUXORplay App

### Product selection

Type	Article number
LUXORliving IP1	4800495

### Technical data

LUXORliving IP1			
Operating voltage	12–30 V DC	Type of protection	IP 20
Stand-by consumption	< 1,5 W	Protection class	III
Width	2 modules		

# Home and building control

## Smart Home system LUXORliving, Power supply



### Description

- 640 mA supply voltage LUXORliving
- 30 V DC auxiliary supply
- Power-supplying and monitoring of the system voltage

### Product selection

Type	Article number
LUXORliving P640	4800990

### Technical data

LUXORliving P640			
Operating voltage	230–240 V AC	Mains failure bridging time	min.100 ms
Stand-by consumption	< 0,8 W	Protection class	II according to EN 60 730-1
Width	4 modules	Type of protection	IP 20
KNX output	1 line with integrated throttle drive		

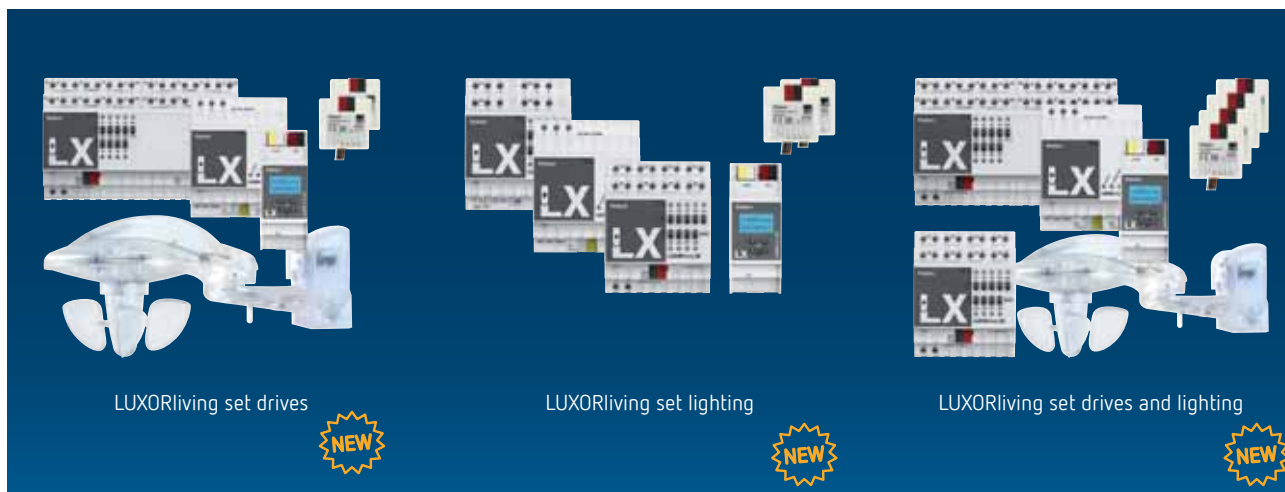

## Description

### LUXORliving set drives

- containing LUXORliving IP1, LUXORliving P640, LUXORliving M140, LUXORliving J8, 2x LUXORliving T4

### LUXORliving set lighting

- containing LUXORliving IP1, LUXORliving P640, LUXORliving S8, LUXORliving D4, 2x LUXORliving T4

### LUXORliving set drives and lighting

- containing LUXORliving IP1, LUXORliving P640, LUXORliving M140, LUXORliving S8, LUXORliving D4, LUXORliving J8, 4x LUXORliving T4

## Product selection

Type	Article number
LUXORliving set drives	4990010
LUXORliving set lighting	4990011
LUXORliving set drives lighting	4990012



LUXOR 400

LUXOR 404

LUXOR 402

## Description

### Common functions

- Modular expandable system with central functions
- For switching electrical consumers
- Manual switch on device
- LEDs to display
- 2 time functions (staircase light function with switch-off warning, lag function)
- Upgradeable for up to 16 LUXOR modules
- Central ON/OFF, panic function and presence simulation
- LUXOR modules are connected via 2-wire bus cable (COM bus)

- Max. input cable length up to 100 m
- Input separate for connecting RCD
- Universal voltage input: 8–48 V AC/DC (e.g. for intercoms)
- Control for configuring central functions

### LUXOR 400

- 4-channel base device for lighting control
- Selector switch for configuring central functions
- Inputs U1 and I4 floating

### LUXOR 404

- 4-channel upgrade device for lighting control
- Input I4 potential-free

### LUXOR 402

- 2-channel upgrade device for lighting control

## Product selection

Type	Article number
LUXOR 400	4000000
LUXOR 404	4040000
LUXOR 402	4020000

Technical data

	LUXOR 400	LUXOR 404	LUXOR 402
Operating voltage	230 V AC		
Frequency	50 Hz		
Width	4 modules		2,5 modules
Installation type	DIN rail		
Stand-by consumption	1,7 W	1,3 W	
Number of channels	4		2
Type of contact	NO contact		
Connecting cable	230 V phase-independent supply cable, max. cable length 100 m		
Connection for COM	EIB/KNX bus line type YCYM or Y(ST)Y or communication line J-Y(ST)Y/length up to 100 m		
Switching capacity	16 A (at 250 V AC, cos φ = 1), 6 A (at 250 V AC, cos φ = 0.6)		
Ambient temperature	-10 °C ... +50 °C		
Type of protection	IP 20		
Protection class	II according to EN 60 730-1		

Accessories



Diode module

↳ Art.No.: 9070367

Details page 342



Front panel kit

↳ Art.No.: 9070001

Details page 334

Connection diagrams

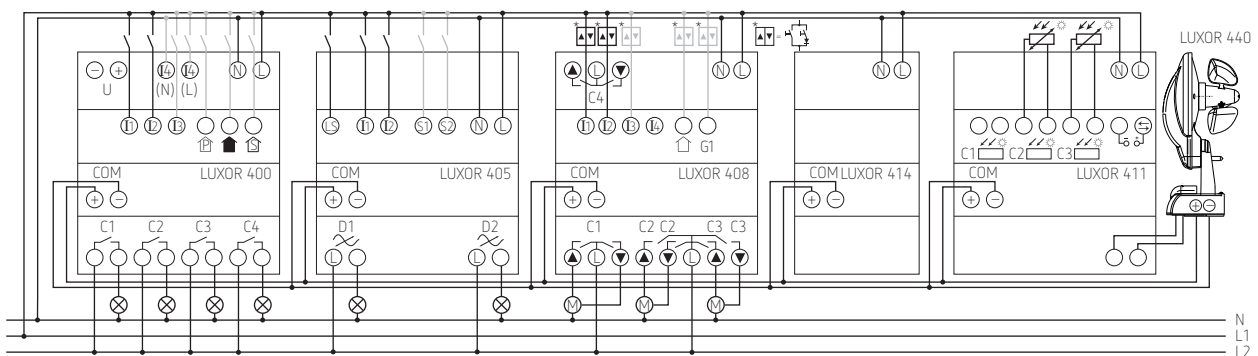



LUXOR 405 S

## Description

- 2-channel universal dimmer
- For dimming electric consumers such as LED, ESL, incandescent lamps, halogen lamps
- Switching capacity per channel:
  - Incandescent and halogen lamp load: 200 W
  - Compact fluorescent lamps (trailing edge): 200 W
  - LED lamps (trailing edge): 200 W
  - Capacity in parallel operation of both channels: 1 x 400 W
- Can also be used without base module
- Manual switch on device
- LEDs to display
- Upgradeable for up to 16 LUXOR modules
- LUXOR modules are connected via 2-wire bus cable (COM bus)
- One additional input per channel for motion detector
- With overcurrent display
- Input for up to 3 light settings
- 4 program options for dimming response
- Central functions: Presence simulation, central OFF, panic function, central ON

## Product selection

Type	Article number
LUXOR 405 S	4050100

## Technical data

	LUXOR 405
Operating voltage	230 V AC
Frequency	50 Hz
Width	4 modules
Installation type	DIN rail
Stand-by consumption	1,3 W
Number of channels	2
Type of contact	Triacs
Connecting cable	230 V phase-independent supply cable, max. cable length 100 m
Connection for COM	EIB/KNX bus line type YCYM or Y(ST)Y or communication line J-Y(ST)Y/length up to 100 m
Ambient temperature	-5 °C ... +45 °C
Type of protection	IP 20
Protection class	II according to EN 60 730-1



LUXOR 408 S



LUXOR 409 S

## Description

### Common functions

- For controlling shutters, awnings or blinds
- Separate control of 4 shutters with UP/DOWN/STOP
- Manual switch on device
- LEDs to display
- Controllable via standard shutter sensor
- Upgradeable for up to 16 LUXOR modules
- LUXOR modules are connected via 2-wire bus cable (COM bus)

- Setting option for panic function (via LUXOR 400)
- Storable intermediate position and turn for shading and ventilation
- 2 diode modules (9070367) supplied in delivery

### LUXOR 408 S

- 4-channel roller shutter base module
- Central UP/DOWN, panic 1 group

- With three group functions (individual, group and central control)
- Expandable via channel upgrade modules, time and sensor module and weather station

### LUXOR 409 S

- 4-channel shutter upgrade module

## Product selection

Type	Article number
LUXOR 408 S	4080100
LUXOR 409 S	4090100

## Accessories



### Diode module

↳ Art.No.: 9070367

Details page 342

## Technical data

	LUXOR 408 S	LUXOR 409 S
Operating voltage	230 V AC	
Frequency	50 Hz	
Width	4 modules	
Installation type	DIN rail	
Stand-by consumption	1,3 W	
Number of channels	4	
Type of contact	NO contact	
Connecting cable	230 V phase-independent supply cable, max. cable length 100 m	
Connection for COM	EIB/KNX bus line type YCYM or Y(ST)Y or communication line J-Y(ST)Y/length up to 100 m	
Switching capacity	6 A (at 250 V AC, $\cos \varphi = 1$ )	
Channel Functions	Shutter, blinds and awning control	
Ambient temperature	-10 °C ... +50 °C	
Type of protection	IP 20	
Protection class	II according to EN 60 730-1	



LUXOR 411

LUXOR 440

### Description

#### LUXOR 411

- Sensor module
- For controlling awnings, shutters and blinds in combination with LUXOR 440, LUXOR 408 S and/or LUXOR 409 S and integrated light sensors
- Setting threshold values on device
- LEDs to display
- Max. input cable length of sensor line is 100 m
- LUXOR modules are connected via 2-wire bus cable (COM bus)

#### LUXOR 440

- Weather sensor
- For controlling awnings, shutters and blinds depending on rain, wind velocity, temperature and brightness in combination with sensor module LUXOR 411, LUXOR 408 S and/or LUXOR 409 S
- Optional connection of up to two additional light sensors for additional facades

### Product selection

Type	Article number
LUXOR 411	4110000
LUXOR 440	4400000

### Technical data

	LUXOR 411	LUXOR 440
Operating voltage	230 V AC	COM-Bus
Frequency	50 Hz	–
Width	4 modules	–
Stand-by consumption	1,1 W	–
Installation type	DIN rail	Wall installation or mast bracket
Connection for COM	EIB / KNX bus line type YCYM or Y(ST)Y or communication line J-Y(ST)Y / length up to 100 m	
Setting range twilight value	1 – 100 lx	
Setting range sun protection	1000 – 100000 lx	
Measuring range wind speed	2 – 20 m/s	
Measuring range temperature	0 °C ... +60 °C	–30 °C ... +60 °C
Ambient temperature	–10 °C ... +50 °C	–20 °C ... +55 °C
Type of protection	IP 20	IP 44
Protection class	II according to EN 60 730-1	

### Accessories



**Surface-mounted light sensor**  
for LUXOR 411  
↳ Art.No.: 9070008  
Details page 342



**Mast mounting S**  
for LUXOR 440  
↳ Art.No.: 9070928  
Details page 345

### Scale drawings

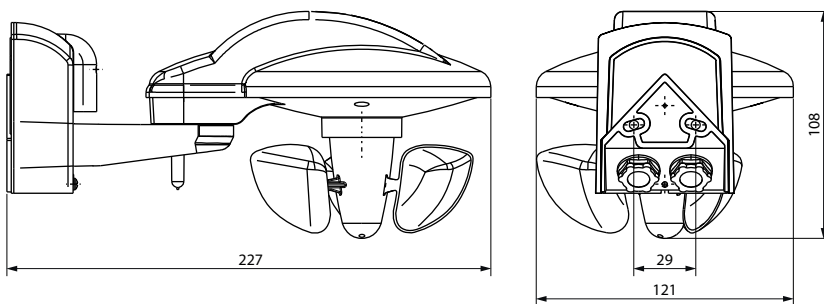

# Home and building control

## Living comfort control, Multifunction display



LUXOR 426

### Description

- Central display and control unit for the LUXOR system
- Time, weekday, date as well as central and automatic functions are displayed
- Current weather conditions are displayed as well as min/max values
- Display with back-lighting
- Favourite sites can be selected from 6 pages
- 8 channel time switch
- Heating temperature reduction in combination with a RAMSES room thermostat
- Manual switching on the device for central and group functions as well as manual and automatic mode
- Daily and weekly programs
- Astronomical program (dependent on sunrise and sunset)
- Freely programmable switching times as well as pre-programmed astronomical switching times
- Offset setting  $\pm 120$  min
- Easy location input via city list
- Individual link of time switch channels with the outputs
- Time controlled positioning of drives (LUXOR 408 S/409 S) as well as transmission of dimming values (LUXOR 405) as percentage values
- Blocking times for suppression of brightness or twilight signals from sensor module (LUXOR 411)
- Astronomical blocking times for time shifts for moving shutters/awnings up and down
- Automatic changeover summer/winter time
- PIN code
- Installation in flush-mounted socket

### Product selection

Type	Article number
LUXOR 426	4260000

### Technical data

	LUXOR 426
Operating voltage	230 V AC
Frequency	50 Hz
Installation type	Wall installation or on flush-mounted socket
Stand-by consumption	1,1 W
Number of channels	8
Connection for COM	EIB / KNX bus line type YCYM or Y(ST)Y or communication line J-Y(ST)Y/length up to 100 m
Number of memory locations	350
Program	Weekly program
Ambient temperature	-5 °C ... +45 °C
Type of protection	IP 20
Protection class	II according to EN 60 335

Scale drawings

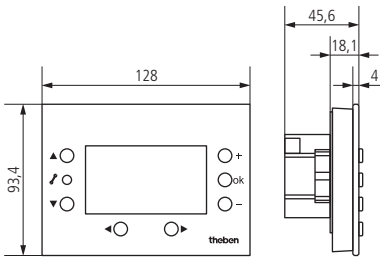

Connection diagrams

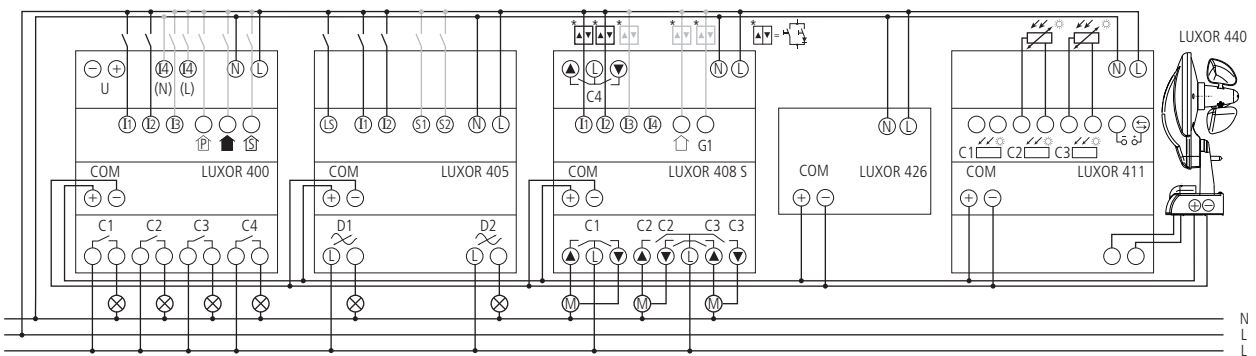
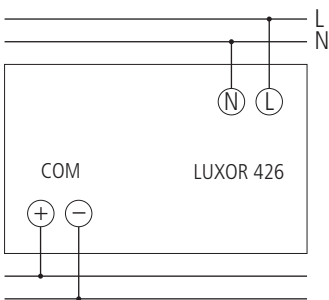

# Home and building control

## Living comfort control, Clock module



LUXOR 414

### Description

- 8-channel time switch
- For control of any outputs in LUXOR system, e.g. shutters, blinds and awnings or for lighting control
- Manual switch on device
- Daily and weekly programs
- Astronomical program (dependent on sunrise and sunset)
- Freely programmable switching times as well as pre-programmed astronomical switching times
- Easy location input via city list
- Individual link of time switch channels with the outputs via selector switch
- Positioning of drives (LUXOR 408/LUXOR 409) as well as transmission of dimming values (LUXOR 405) as percentage values
- Blocking times for suppression of brightness or twilight signals from sensor module (LUXOR 411)
- Astronomical blocking times for time shifts for moving shutters/awnings up and down
- Automatic summer/winter time changeover
- LUXOR modules are connected via 2-wire bus cable (COM bus)

### Product selection

Type	Article number
LUXOR 414	4140000

### Technical data

LUXOR 414	
Operating voltage	230 V AC
Frequency	50 Hz
Width	2,5 modules
Installation type	DIN rail
Stand-by consumption	1,3 W
Number of channels	8
Connection for COM	EIB/KNX bus line type YCYM or Y(ST)Y or communication line J-Y(ST)Y/length up to 100 m
Number of memory locations	128
Ambient temperature	-10 °C ... +50 °C
Type of protection	IP 20
Protection class	II according to EN 60 730-1

### Connection diagrams

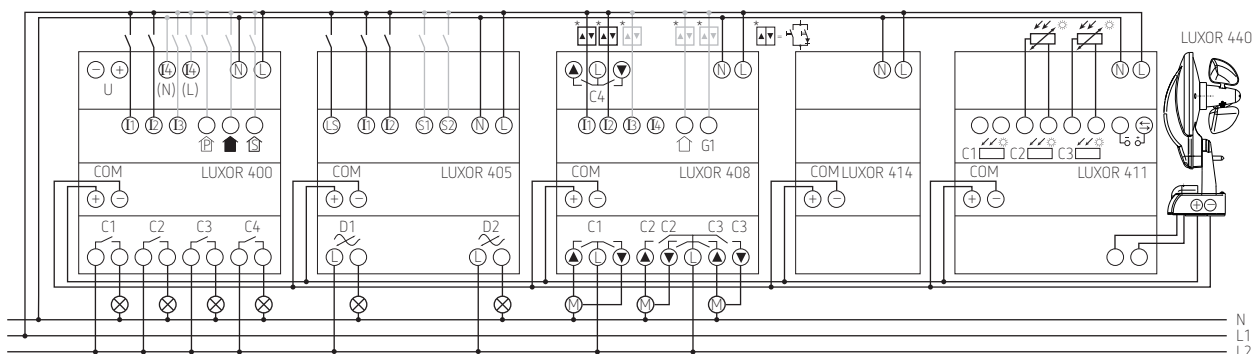



LUXOR Set 4

LUXOR Set 5

## Description

### LUXOR Set 4

- Set for shutter and blind controlling
- 8 drives can be manually or automatically controlled according to time program or sunrise or sunset
- Blocking times for time shifts for moving shutters/awnings up and down in the early morning
- Additional comfortable central functions
- Suitable for shutter and blind 8 drives, 8 drives and 8 time channels with weekly program with astronomical function
- Consisting of: Box, 1 LUXOR 408 S, 1 LUXOR 409 S, 1 LUXOR 414

### LUXOR Set 5

- Set for shutter and blind controlling
- 8 drives can be manually or automatically controlled according to time program or sunrise or sunset
- Blocking times for time shifts for moving shutters/awnings up and down in the early morning
- Additional comfortable central functions
- Suitable for shutter and blind 8 drives, 8 drives and 8 time channels with weekly program with astronomical function
- Consisting of: Box, 1 LUXOR 408 S, 1 LUXOR 409 S, 1 LUXOR 426









## Product selection

Type	Article number
LUXOR Set 4	4990004
LUXOR Set 5	4990005



## Meet people on an equal footing

Theben is present in more than 60 countries throughout the world. We are successfully active in numerous markets. It's not just our persuasive product portfolio that accounts for that. What is decisive is the attitude of people who meet one another on an equal footing and agree about challenges that must be overcome — by solutions that offer a concrete benefit. This openness to markets and people we call open-mindedness.

	Number of inputs	Number of outputs	Operating voltage	Type	Page
<b>Controller</b>					
	6	4	100–240 V AC	PHARAO-II 10 (AC)	330
			24 V DC	PHARAO-II 11 (DC)	330
	8	6	100–240 V AC	PHARAO-II 14 (AC)	330
			24 V DC	PHARAO-II 15 (DC)	330
	15	9	100–240 V AC	PHARAO-II 24 (AC)	330
			24 V DC	PHARAO-II 25 (DC)	330
	–	4	220–240 V AC	PHARAO-II extension 4AR (AC)	330
		–	24 V DC	LUNA 131 DDC	332
	1	1	100–240 V AC	SUD 228 II	332

# Home and building control

## Controller, Controller



### Description

#### Common functions

- Small control unit for house automation and industry
- Programming directly on device via eight buttons without interface cable
- Display back light with operator guidance in clear text
- Input and output switching status display
- Lifespan of relay contacts is 100,000 switching cycles at nominal current
- Assignment of programmed functions on front keys
- Internal EEPROM memory for max. 200 function blocks (5,000 bytes)
- Optional plug-in EEPROM for program transfer or dual programming of internal and plugged-in EEPROM
- 3-level password protection
- Realtime year clock with 1,000 switching times
- Graphical programming software for Windows 95/98/NT/2000/ME/XP with detailed online Help documentation
- Remote control/remote monitoring possible via modem/GSM modem
- Transmission of SMS, email or fax

#### PHARAO-II 10 (AC)

- Small control unit for house automation and industry
- Operating voltage 100–240 V AC
- 6 digital inputs, e.g. for keys, brightness and temperature switches
- 4 relay outputs

#### PHARAO-II 11 (DC)

- Operating voltage 24 V DC
- 6 digital/analogue inputs
- 4 relay outputs

#### PHARAO-II 14 (AC)

- Operating voltage 100–240 V AC
- 8 digital inputs, e.g. for keys, brightness and temperature switches
- 6 relay outputs

#### PHARAO-II 15 (DC)

- Operating voltage 24 V DC
- 8 digital/analogue inputs
- 6 relay outputs

#### PHARAO-II 24 (AC)

- Operating voltage 100–240 V AC
- 15 digital inputs, e.g. for keys, brightness and temperature switches
- 9 relay outputs

#### PHARAO-II 25 (DC)

- Operating voltage 24 V DC
- 15 inputs, including 8 analogue/digital options
- 9 relay outputs

#### PHARAO-II extension 4AR (AC)

- 4 channel relay output extension
- For PHARAO-II 14 (AC), PHARAO-II 24 (AC)

### Product selection

Number of inputs	Number of outputs	Operating voltage	Type	Article number
6	4	100–240 V AC	PHARAO-II 10 (AC)	5750210
		24 V DC	PHARAO-II 11 (DC)	5759211
8	6	100–240 V AC	PHARAO-II 14 (AC)	5750014
		24 V DC	PHARAO-II 15 (DC)	5759015
15	9	100–240 V AC	PHARAO-II 24 (AC)	5750024
		24 V DC	PHARAO-II 25 (DC)	5759025
-	4	220–240 V AC	PHARAO-II extension 4AR (AC)	5759102

## Technical data

	PHARAO-II 10 (AC)	PHARAO-II 11 (DC)	PHARAO-II 14 (AC)	PHARAO-II 15 (DC)	PHARAO-II 24 (AC)	PHARAO-II 25 (DC)	PHARAO-II extension 4AR (AC)
Operating voltage	100–240 V AC	24 V DC	100–240 V AC	24 V DC	100–240 V AC	24 V DC	220–240 V AC
Frequency	50–60 Hz	–	50–60 Hz	–	50–60 Hz	–	50–60 Hz
Stand-by consumption	1,2 W	0,4 W	1,3 W	0,4 W	1,3 W	0,4 W	–
Width	4 modules		7 modules				–
Installation type	DIN rail						Encajable
Type of contact	NO contact						
Switching capacity	8 A (at 250 V AC, $\cos \phi = 1$ ), 373 VA (at 250 V AC, inductive load)				4 x 8 A (250 V AC, $\cos \phi = 1$ ), inductive load max. 373 VA, 5 x 2 A (250 V AC, $\cos \phi = 1$ ), inductive load max. 93 VA		2 A (at 250 V AC, $\cos \phi = 1$ )
Power reserve	20 days						–
Time accuracy at 25 °C	$\leq \pm 5$ s/day (quartz)						–
Input frequency	5 Hz	20 Hz					–
Ambient temperature	-25 °C ... +55 °C						–
Type of protection	IP 20						–
Protection class	II according to EN 60 730-1						–

## Accessories



Power unit 24 V DC  
↳ Art.No.: 9079330  
Details page 345



Memory module PHARAO-II  
↳ Art.No.: 9070328  
Details page 345

GSM cable PHARAO-II  
Details page 345

Programming cable PHARAO  
Details page 345

## Connection diagrams

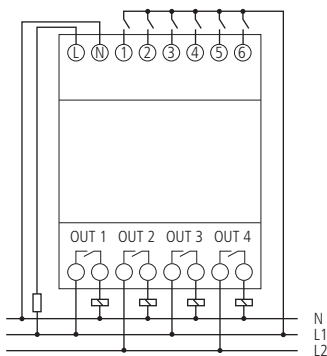

PHARAO-II 10 (AC)

# Home and building control

## Controller, Controller



LUNA 131 DDC

SUD 228 II

### Description

#### LUNA 131 DDC

- Combination sensor with analogue output signal
- Can be used for brightness and temperature measurement
- Each of the two measurement outputs represents a 0-10 V analogue output signal
- The sensor can be connected directly to the analogue inputs of the PHARAO devices (24 V DC)
- Controls and regulators can be programmed with the signal converter, range compare and Schmitt trigger function modules
- External 24 V DC power unit required

#### SUD 228 II

- Charging switch for electric storage heaters
- Adjustable charging time and backward control
- If the ripple control receiver or the tariff time switch have been released for night-time off-peak tariff, the device starts the charging program for storage heating
- Charging time can be set from 0–9 hours
- Onscreen display of charging time which is repeated every 24 hours
- Backward control stops charging process at the end of off-peak period
- Manual switch can be connected for daytime charging

### Product selection

Type	Article number
LUNA 131 DDC	1319700
SUD 228 II	2280577

## Technical data

	LUNA 131 DDC	SUD 228 II
Operating voltage	24 V DC	100–240 V AC
Frequency	–	50–60 Hz
Stand-by consumption	–	1,2 W
Width	–	4 modules
Installation type	Surface-mounted	DIN rail
Type of contact	–	NO contact
Switching capacity	–	8 A (at 250 V AC, $\cos \phi = 1$ )
Measuring range brightness	10–50000 lx	–
Measuring range temperature	-30 °C ... +70 °C	–
Ambient temperature	-30 °C ... +70 °C	+0 °C ... +55 °C
Type of protection	IP 54	IP 20
Protection class	–	II according to EN 60 730-1

## Accessories



Power unit 24 V DC  
↳ Art.No.: 9079330  
Details page 345

## Scale drawings

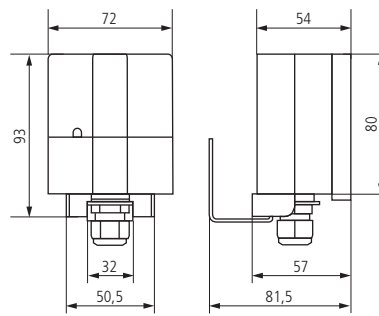

LUNA 131 DDC

## Connection diagrams

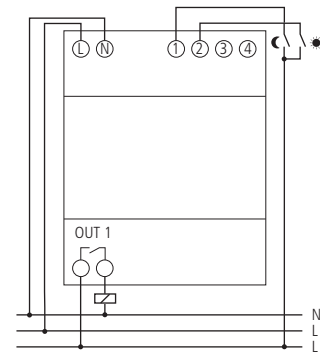

SUD 228 II







## Accessories

	Description	Suitable for	Type	Article number
	<b>Wall mounting kit 17,5 mm</b> - Terminal box cover plate for assembly, sealable	- All DIN rail installation devices - width 1 module	Wall mounting kit 17,5 mm	9070065
	<b>Wall mounting kit 35 mm</b> - Terminal box cover plate for assembly, sealable	- All DIN rail installation devices - width 2 modules	Wall mounting kit 35 mm	9070064
	<b>Wall mounting kit 52,5 mm</b> - Terminal box cover plate for assembly, sealable	- All DIN rail installation devices - width 3 modules	Wall mounting kit 52,5 mm	9070050
	<b>Wall mounting kit 70 mm</b> - Terminal box cover plate for assembly, sealable	- All DIN rail installation devices - width 4 modules	Wall mounting kit 70 mm	9070049
	<b>Terminal cover 52,5 mm</b> - Terminal box cover plate for assembly, sealable	- SUL 188 g - SUL 188 hw	Terminal cover 52,5 mm	9070061
	<b>Front panel kit</b> - The front panel installation set is suitable for Theben distributor installation devices of 17,5 to 107,5 mm width - Walls from 1 to 5 mm thick	- All DIN rail installation devices	Front panel kit	9070001
	<b>Snap-on mounting 72 x 72</b> - Quick fastening for 35 mm DIN-rail	- All devices for front panel/wall installation	Snap-on mounting 72 x 72	9070071
	<b>Multiple contact strip</b> - Multiple contact strip for soldering to PCBs	- TR 684 top2	Multiple contact strip	9075141
	<b>Light sensor theRolla</b> - Light sensor for time switch	- theRolla P032	Light sensor theRolla	9070926









	Description	Suitable for	Type	Article number
	<p><b>PC set OBELISK top2/3</b></p> <ul style="list-style-type: none"> <li>- Switching programs created on the PC by means of the convenient OBELISK top2/3 software can be transferred via USB interface to the OBELISK top2 memory card and from the card to the time switch and vice versa. Thus no PC or laptop is required on-site. Programming and the program printout can be done comfortably from the desk</li> <li>- For Windows XP/Vista/7/8/10 (32/64 Bit)</li> <li>- Consisting of: Memory card, USB plug adapter, software</li> <li>- Updates of existing OBELISK top2 software are available as free downloads at <a href="http://www.theben.de">www.theben.de</a></li> </ul>	<ul style="list-style-type: none"> <li>- TR top2</li> <li>- TR top3</li> <li>- LUNA top2</li> <li>- SELEKTA top2</li> <li>- SELEKTA top3</li> <li>- TR top2 KNX</li> </ul>	PC set OBELISK top2	9070409
	<p><b>Bluetooth OBELISK top3</b></p> <ul style="list-style-type: none"> <li>- Bluetooth low-energy dongle for the transfer of switching programs and direct commands from the app to the time switch</li> <li>- Maximum manipulation security, Time switch programs can only be transferred from the app to the time switch when the Bluetooth OBELISK top3 is plugged into the time switch</li> <li>- Low consumption on standby compared with permanently installed Bluetooth components</li> </ul>	<ul style="list-style-type: none"> <li>- TR top3</li> <li>- SELEKTA top3</li> </ul>	Bluetooth OBELISK top3	9070130
	<p><b>Memory card OBELISK top2</b></p> <ul style="list-style-type: none"> <li>- Individual memory card</li> </ul>	<ul style="list-style-type: none"> <li>- TR top2</li> <li>- LUNA top2</li> <li>- SELEKTA top2</li> <li>- TR top2 KNX</li> </ul>	Memory card OBELISK top2	9070404
	<p><b>Antenna DCF77 KNX</b></p> <ul style="list-style-type: none"> <li>- Radio control via DCF antenna with KNX time switches: To ensure good reception, do not install the antenna in cellars or on distribution boxes. Connection is made via separate 2-wire, unshielded high-voltage power cable (max. 100 m), up to 10 Theben top2 RC devices can be connected. Polarity, short-circuit and interruption of the antenna circuit are each visually displayed to help with installation.</li> </ul>	<ul style="list-style-type: none"> <li>- ZS 600 DCF KNX</li> </ul>	Antenna DCF77 KNX	9070271
	<p><b>Antenna top2 RC-DCF</b></p> <ul style="list-style-type: none"> <li>- Radio control via DCF antenna with top2 RC devices: To ensure good reception, do not install the antenna in cellars or on distribution boxes. Connection is made via separate 2-wire, unshielded high-voltage power cable (max. 100 m), up to 10 Theben top2 RC devices can be connected. Polarity, short-circuit and interruption of the antenna circuit are each visually displayed to help with installation.</li> </ul>	<ul style="list-style-type: none"> <li>- TR top2 RC</li> <li>- LUNA top2 RC</li> <li>- SELEKTA top2 RC</li> <li>- TR top2 KNX</li> </ul>	Antenna top2 RC-DCF	9070410
	<p><b>Antenna top2 RC-GPS</b></p> <ul style="list-style-type: none"> <li>- Worldwide time synchronisation and positioning via receiving GPS satellite signal</li> <li>- The antenna is connected by a 2 wire cable (max. 100 m) to Theben top2 RC devices (up to 5 devices can be connected depending on device type)</li> <li>- A top2 GPS power unit (item number 907 0 892) is also required when connecting to TR 611 top2 RC, LUNA 121 top2 RC, LUNA 122 top2 RC or SELEKTA 171 top2 RC devices</li> <li>- No additional power unit is required when connecting to TR 641 top2 RC, TR 642 top2 RC, TR 644 top2 RC devices or several devices to one antenna</li> <li>- Positioning is only possible when connecting to TR 641 top2 RC, TR 642 top2 RC, TR 644 top2 RC and SELEKTA 171 top2 RC devices</li> <li>- Can not be used with TR 611 top2 RC 24 V and SELEKTA 171 top2 RC 24V</li> </ul>	<ul style="list-style-type: none"> <li>- TR top2 RC</li> <li>- LUNA top2 RC</li> <li>- SELEKTA top2 RC</li> <li>- TR top2 KNX</li> </ul>	Antenna top2 RC-GPS	9070610









## Accessories

	Description	Suitable for	Type	Article number
	<b>Power unit top2 GPS</b> - Required when connecting the antenna top2 RC-GPS to an individual TR 611 top2 RC, LUNA 121 top2 RC, LUNA 122 top2 RC or SELEKTA 171 top2 RC device (No additional power unit is required when connecting to a minimum of 2 devices) - Operating voltage: 230 V AC - Width: 2 modules	- TR top2 RC - LUNA top2 RC - SELEKTA top2 RC	Power unit top2 GPS	9070892
	<b>Cover 55 x 55 for BZ</b> - Cover for hour counter	- BZ 142-1	Cover 55 x 55 for BZ	9070041
	<b>Cover 72 x 72 for BZ</b> - Cover for hour counter	- BZ 142-1	Cover 72 x 72 for BZ	9070074
	<b>Front kit BZ 142-3</b> - Terminal box cover plate for hour counter	- BZ 142-3	Front kit BZ 142-3	9070075
	<b>Clamp BZ</b> - Clamping bracket for hour counter	- BZ 142-1 - BZ 143-1 - BZ 146 - BZ 147	Clamp BZ	9070043
	<b>Plug-in socket BZ</b> - Plug-in base for hour counter	- BZ 142-3	Plug-in socket BZ	9070042
	<b>Surface frame PresenceLight</b> - Presence detector surface frame	- PresenceLight 180 - PresenceLight 360	Surface frame PresenceLight (white)	9070513
			Surface frame PresenceLight BK (black)	9070634
			Surface frame PresenceLight SR (silver)	9070635
	<b>Cover frame PresenceLight 360</b> - Cover frame for presence detector PresenceLight 360	- PresenceLight 360	Cover frame PresenceLight 360 WH (white)	9070510
			Cover frame PresenceLight 360 BK (black)	9070632
			Cover frame PresenceLight 360 SR (silver)	9070631

	Description	Suitable for	Type	Article number
	<b>Cover frame PresenceLight 180</b> - Cover frame for presence detector PresenceLight 180	- PresenceLight 180	Cover frame PresenceLight 180 WH (white)	9070629
			Cover frame PresenceLight 180 BK (black)	9070628
			Cover frame PresenceLight 180 SR (silver)	9070627
	<b>Surface frame compact</b> - Presence detector surface frame	- compact office - compact passage - compact passimo	Surface frame compact (white)	9070514
			Surface frame compact BK (black)	9070637
			Surface frame compact SR (silver)	9070638
	<b>Surface frame 110A</b> - Presence detector surface frame	- thePrema - theRonda P - theMova P	Surface frame 110A WH (white)	9070912
			Surface frame 110A GR (grey)	9070913
	<b>Surface frame 110B</b> - Presence detector surface frame	- thePrema KNX	Surface frame 110B WH (white)	9070918
			Surface frame 110B GR (grey)	9070919
	<b>Ceiling installation box 73A</b> - Ceiling installation unit, ensures strain relief and contact protection at the same time. The installation diameter is 72 mm (drill diameter 73 mm)	- thePrema - theRonda P - theMova P - compact passage - compact passimo - PresenceLight	Ceiling installation box 73A	9070917
	<b>Masking clip</b> - For limiting the detection area	- theRonda P - theMova P	Masking clip	9070921
	<b>Surface frame 75A</b> - Presence detector surface frame	- PlanoSpot	Surface frame 75A WH (white)	9070949
			Surface frame 75A BK (black)	9070950
			Surface frame 75A SR (silver)	9070951

## Accessories

	Description	Suitable for	Type	Article number
	<b>Cover frame PlanoCover</b> - Cover frame for presence detector PlanoSpot - Diameter 76 mm	- PlanoSpot	PlanoCover 76 WH (white)	9070976
			PlanoCover 76 BK (black)	9070977
			PlanoCover 76 SR (silver)	9070978
	<b>PlanoBox 1WH</b> - Presence detector surface frame - Dimensions: 100 x 123 x 123 mm	- PlanoCentro U	PlanoBox 1WH (white)	9070731
			PlanoBox 1BK (black)	9070732
			PlanoBox 1SR (silver)	9070733
	<b>PlanoSet RQ</b> - Mounting set consisting of round flush-mounting box PlanoFix E, white matching square cover PlanoCover and assembly parts - Easy and fast mounting in false-ceilings - Cut-out can be easily realized with a standard drill bit diameter 127 mm (5 inches) - The following installation and alignment of the presence detector PlanoCentro is implemented very easily and quickly - Frame PlanoCover: 142 x 142 mm	- PlanoCentro E	PlanoSet RQ EWH (white)	9070736
			PlanoSet RQ EBK (black)	9070737
			PlanoSet RQ ESR (silver)	9070738
	<b>PlanoSet RR</b> As PlanoSet RQ, but: - Round cover PlanoCover - Frame PlanoCover: Ø 172 mm	- PlanoCentro E	PlanoSet RR EWH (white)	9070740
			PlanoSet RR EBK (black)	9070741
			PlanoSet RR ESR (silver)	9070742
	<b>Cover frame PlanoCover E</b> - Cover frame for presence detector PlanoCentro E - Dimensions 112 x 112 mm	- PlanoCentro E	PlanoCover EWH-112x112 (white)	9070677
			PlanoCover EBK-112x112 (black)	9070678
			PlanoCover ESR-112x112 (silver)	9070679
	<b>Cover frame PlanoCover U</b> - Cover frame for presence detector PlanoCentro U - Dimensions 123 x 123 mm	- PlanoCentro U	PlanoCover UWH-123x123 (white)	9070680
			PlanoCover UBK-123x123 (black)	9070681
			PlanoCover USR-123x123 (silver)	9070682
	<b>Junction casing, 115x115x100 mm</b> - Agro/Kaiser flush-mounted junction box/connection box 9908.01	- PlanoCentro U	Junction casing, 115 x 115 x 100 mm	9070689
	<b>QuickSafe</b> - QuickSafe safety cover - Secure protection against mechanical damage - Robust and solid design - Particularly impact resistant - 6 screws, 3 rawlplugs and three spacers - Protection class IK07	- All ThebenHTS presence detectors	QuickSafe	9070531

	Description	Suitable for	Type	Article number
	<b>SendoPro 868-A</b> - Infrared remote control for the convenient startup of HTS presence detectors - The SendoPro 868A management remote control for the electrician enables efficient start-up and flexible adaptation to new applications - Rapid adjustment of parameters to changed operating conditions without uninstalling detectors - Transmission of individual settings or complete configuration sets to the detector - Select configurations from PlanoCentro - Calling up of pre-defined parameter sets for typical rooms - Saving and calling up user-defined parameter sets on internal memory or SD card - Updates via SD card	- PresenceLight - compact office - compact passage - compact passimo - thePrema - ECO-IR DUAL-C NT - PlanoCentro - PlanoSpot	SendoPro 868-A	9070675
	<b>RC filter</b> - Suppression filter for presence and motion detectors	- All presence and motion detectors	RC filter	9070523
	<b>Corner angle theLuxe E BK</b> - For corner installation of motion detectors - Wall installation, external corner installation	- theLuxe E180	Corner angle theLuxe E BK	9070975
	<b>Corner angle theLuxe E WH</b> - For corner installation of motion detectors - Wall installation, external corner installation	- theLuxe E180	Corner angle theLuxe E WH	9070974
	<b>Spacer theLuxe S BK</b> - Additional spacer for flexible installation (cable entry below, side, top and more space for cables)	- theLuxe S150 - the LuxaS180 - theLuxe S360	Spacer theLuxe S BK	9070907
	<b>Spacer theLuxe S WH</b> - Additional spacer for flexible installation (cable entry below, side, top and more space for cables)	- theLuxe S150 - the LuxaS180 - theLuxe S360	Spacer theLuxe S WH	9070906
	<b>Spacer theLuxe P BK</b> - Additional spacer for flexible installation (cable entry below, side, top and more space for cables)	- theLuxe P220 - theLuxe P300 - theLuxe P300 KNX	Spacer theLuxe P BK	9070909
	<b>Spacer theLuxe P WH</b> - Additional spacer for flexible installation (cable entry below, side, top and more space for cables)	- theLuxe P220 - theLuxe P300 - theLuxe P300 KNX	Spacer theLuxe P WH	9070908

## Accessories

	Description	Suitable for	Type	Article number
	<b>Corner angle theLuxe S BK</b> - For corner installation of motion detectors - Wall installation, external corner installation	- theLuxe S150 - theLuxe S180 - theLuxe S360	Corner angle theLuxe S BK	9070903
	<b>Corner angle theLuxe S WH</b> - For corner installation of motion detectors - Wall installation, external corner installation	- theLuxe S150 - theLuxe S180 - theLuxe S360	Corner angle theLuxe S WH	9070902
	<b>Corner angle theLuxe P BK</b> - For corner installation of motion detectors - Wall installation, external corner installation	- theLuxe P220 - theLuxe P300 - theLuxe P300 KNX	Corner angle theLuxe P BK	9070905
	<b>Corner angle theLuxe P WH</b> - For corner installation of motion detectors - Wall installation, external corner installation	- theLuxe P220 - theLuxe P300 - theLuxe P300 KNX	Corner angle theLuxe P WH	9070904
	<b>Corner angle 10 AL</b> - For corner installation of motion detectors - Wall installation, external corner installation	- theLeda P - theLeda S - theLuxe R	Corner 10 AL	9070970
	<b>Corner angle 10 BK</b> - For corner installation of motion detectors - Wall installation, external corner installation	- theLeda P - theLeda S - theLuxe R	Corner angle 10 BK	9070987
	<b>Corner angle 10 WH</b> - For corner installation of motion detectors - Wall installation, external corner installation	- theLeda P - theLeda S - theLuxe R	Corner angle 10 WH	9070969
	<b>Spacer 10 AL</b> - Additional spacer for flexible installation (cable entry below, side, top and more space for cables)	- theLeda P - theLeda S - theLuxe R	Spacer 10 AL	9070972
	<b>Spacer 10 BK</b> - Additional spacer for flexible installation (cable entry below, side, top and more space for cables)	- theLeda P - theLeda S - theLuxe R	Spacer 10 BK	9070988
	<b>Spacer 10 WH</b> - Additional spacer for flexible installation (cable entry below, side, top and more space for cables)	- theLeda P - theLeda S - theLuxe R	Spacer 10 WH	9070971

	Description	Suitable for	Type	Article number
	<b>Surface frame LUXA 103-100</b> - Motion detector surface frame	- LUXA 103-100 U - LUXA 103-100 UA	Surface frame LUXA 103-100 U	9070986
	<b>Surface frame LUXA 103-200</b> - Motion detector surface frame	- LUXA 103-200	Surface frame LUXA 103-200	9070504
	<b>SPHINX RC 104</b> - User remote control for SPHINX 104 - ON/OFF (max. 8 h)/Automatic - Teach-in function for teaching in the current brightness value	- SPHINX 104-360 - SPHINX 104-360 / 2 - SPHINX 104-360 AP - SPHINX 104-360 / 2 AP	SPHINX RC 104	9070538
	<b>SPHINX RC 104 Pro</b> - Service remote control for SPHINX 104 - ON/OFF - Teach-in function for teaching in the current brightness value - Predefined brightness values and switch-on times - Impulse, reset and test function - Block function	- SPHINX 104-360 - SPHINX 104-360 / 2 - SPHINX 104-360 AP - SPHINX 104-360 / 2 AP	SPHINX RC 104 Pro	9070536
	<b>theSenda P</b> - Service remote control - ON/OFF - Teach-in function for teaching in the current brightness value - Predefined brightness values and switch-on times - Impulse, reset and test function	- PlanoCentro - PlanoCentro KNX - PresenceLight KNX - compact office DALI - thePrema - theMova - theRonda - theLuxa P - theLeda P - PlanoSpot	theSenda P	9070910
	<b>theSenda S</b> - User remote control - ON/OFF - Automatic - Presence simulation - Twilight switch - Call up of light scenes	- PlanoCentro - PlanoCentro KNX - PresenceLight KNX - compact office DALI - thePrema - theMova - theRonda - theLuxa P - theLeda P - PlanoSpot	theSenda S	9070911
	<b>Adapter plate LUNA star</b> - The adapter plate simplifies the replacement of faulty twilight switches from Eberle, ESYLUX, Legrand, Grässlin, Hager, Merten, Senmatic, Theben etc. As the plate has standard fixing holes, no further holes need to be drilled in the facade, 2 installation screws included.	- LUNA 126 star - LUNA 127 star - LUNA 128 star - LUNA 129 star-time	Adapter plate LUNA star	9070486
	<b>Analogue flush-mounted light sensor</b> - Connecting cable 1.5 m - Protection class IP 65	- LUNA 108 - LUNA 109 - LUNA 110 - LUNA 120 top2	Analogue flush-mounted light sensor	9070011

## Accessories

	Description	Suitable for	Type	Article number
	<b>Analogue surface-mounted light sensor</b> - Sensor rotatable - With mounting bracket and screw terminals - Protection class IP 55 - Dimensions: 95 x 48 x 45 mm	- LUNA 109 - LUNA 110 - LUNA 120 top2	Analogue surface-mounted light sensor	9070416
	<b>Digital flush-mounted light sensor</b> - Spring terminals - Protection class IP 66	- LUNA 111 top2 - LUNA 112 top2 - LUNA 121 top2 RC - LUNA 122 top2 RC - LUNA 134 KNX	Digital flush-mounted light sensor	9070456
	<b>Digital surface-mounted light sensor</b> - Sensor rotatable - With mounting bracket and screw terminals - Protection class IP 55 - Dimensions: 95 x 48 x 45 mm	- LUNA 111 top2 - LUNA 112 top2 - LUNA 121 top2 RC - LUNA 122 top2 RC - LUNA 134 KNX	Digital surface-mounted light sensor	9070415
	<b>Surface-mounted light sensor</b> - Sensor rotatable - With mounting bracket and Screw terminals - Protection class IP 54 - Dimensions: 116 x 27 x 61 mm	- LUNA 108 - LUXOR 411	Surface-mounted light sensor	9070008
	<b>Diode module</b> - Required for special functions (group/central function) with LUXOR - DIMAX: Light scenes, two button operation - 2 modules supplied in delivery	- LUXOR 400 - LUXOR 402 - LUXOR 404 - LUXOR 405 - LUXOR 408 S - LUXOR 409 S - DIMAX 534 plus - DIMAX 542/544 plus	Diode module	9070367
	<b>Adapter RAMSES 72x/78x</b> - Wallpaper / wall cover plate for replacement of RAMSES 3...devices with new clock thermostats, e.g. RAMSES 722	- RAMSES 722 - RAMSES 722 S - RAMSES 782 - RAMSES 782 S - RAMSES 784 - RAMSES 784 S - RAMSES 721 - RAMSES 725	Adapter RAMSES 72x/78x	9070245
	<b>Socket RAMSES</b> - Plug-in socket for installing the RAMSES HF clock thermostat on the wall	- RAMSES 813 top2 Set A/ Set S/Set 1 - RAMSES 833 top2 Set 1/2	Socket RAMSES	9070605
	<b>Adapter plate RAMSES 70x</b> - Adapter plate for flush-mounted socket 79 x 79 mm	- RAMSES 701-709	Adapter plate RAMSES 70x	9070480

	Description	Suitable for	Type	Article number
	<b>Adapter plate RAMSES 714</b> - Adapter plate for flush-mounted socket 79 x 79 mm	- SOTHIS 715 - RAMSES 714 - RAMSES 714 A - RAMSES 714 A/FH	Adapter plate RAMSES 714	9070212
	<b>External temperature sensor 1</b> - External temperature sensor	- RAMSES 366/1 top2 - RAMSES 718 S/P KNX - RAMSES 713 FC KNX - CHEOPS control KNX - AMUN 716 S KNX	External temperature sensor 1	9070191
	<b>External temperature sensor 2</b> - With temperature adjustment of $\pm 3$ K	- RAMSES 366/1 top2	External temperature sensor 2	9070192
	<b>Temperature sensor RAMSES IP 65</b> - External room temperature sensor - Protection class IP 65	- RAMSES 831 top2 - RAMSES 832 top2 - RAMSES 833 top2 - RAMSES 833 top2 Sets - RAMSES 816 top2 OT - RAMSES 856 top2 OT - AMUN 716 S KNX - RAMSES 718 S/P KNX	Temperature sensor RAMSES IP 65	9070459
	<b>Temperature sensor</b> - Temperature sensor for laying in floor - Type of protection IP 65	- RAMSES 831 top2 - RAMSES 832 top2 - RAMSES 833 top2 Sets - RAMSES 712 KNX - FCA 1 KNX - AMUN 716 S KNX - RAMSES 718 S/P KNX	Temperature sensor	9070321
	<b>OT-Box Standard</b> - For expansion of the RAMSES 856 top2 OT system	- RAMSES 856 top2 OT	OT-Box Standard	9070712
	<b>Flow temperature sensor RAMSES</b> - Also required for applications with 2 feed sensors	- RAMSES 816 top2 OT - RAMSES 856 top2 OT	Flow temperature sensor RAMSES	9070371
	<b>Outside temperature sensor RAMSES</b> - Type of protection IP 65	- RAMSES 816 top2 OT	Outside temperature sensor	9070463

## Accessories

	Description	Suitable for	Type	Article number
	<b>Plunge sensor RAMSES</b> - Additionally required for applications with domestic water control or boiler plunge sensor	- RAMSES 816 top2 OT - RAMSES 856 top2 OT	Plunge sensor RAMSES	9070379
	<b>Actuator ALPHA 5 230 V</b> - Actuator for radiators, heating circuit distributors or individual heating circuits - Operating voltage 230 V AC - For opening and closing of valves in the fields of heating, ventilation and air conditioning - The actuator control is by a room thermostat with two-point output or pulse-width-modulation - Inrush current max. 250 mA for max. 2 min., Operating current 75 mA - „First open function“ for easy installation and heating start-up - Plug-in installation on valve adapter to suit the most common valve bottoms and heating circuit distributors - Normally closed (Valve is closed when the operating voltage is cut) - Simple snap-on mounting to a valve adapter - Valve adapter not included in delivery - 100 % protection against damaging drives through leaking valves - Function and adjustment checking - Installation vertical, horizontal and up-side-down possible - Up-side-down position may reduce product life through special circumstances (e.g. contaminated water) - Protection against disassembly by means of removable SaveGuard - Guaranteed overvoltage protection	- All clock thermostats - RAMSES 701 – 709 - RAMSES 741 – 748 - RAMSES 714 - RAMSES 751 - HMG 6 T - HME 6 T KNX - HM 6 T KNX - HM 12 T KNX	Actuator ALPHA 5 230 V	9070441
	<b>Actuator ALPHA 5 24 V</b> As Actuator ALPHA 5 230 V, but: - Operating voltage 24 V AC/DC	- All clock thermostats - HMG 6 T - HME 6 T KNX - HM 6 T KNX - HM 12 T KNX - HMT 6 S KNX - HMT 12 S KNX	Actuator ALPHA 5 24 V	9070442
	<b>Valve adapter VA 80</b> - Valve adapters for Onda, Schlösser(from 1993), Oventrop (M 30 x 1.5), Heimeier, Herb, Therm-Concept, Frank, Roth (distributor), Dinotherm (distributor) - Other adapters available upon request	- ALPHA 5 230 V - ALPHA 5 24 V - CHEOPS control KNX - CHEOPS drive KNX	Valve adapter VA 80	9070437
	<b>Valve adapter VA 78</b> - Valve adapters for Danfoss RA - Other adapters available upon request	- ALPHA 5 230 V - ALPHA 5 24 V - CHEOPS control KNX - CHEOPS drive KNX	Valve adapter VA 78	9070436
	<b>Frame RAMSES 74x</b> - Frame for mechanical room thermostats - Without central part	- RAMSES 741 - RAMSES 746 - RAMSES 748	Frame RAMSES 74x	9070603

	Description	Suitable for	Type	Article number
	<b>Central part RAMSES 741/748</b> - Central part without switch section and setting button	- RAMSES 741 - RAMSES 748	Central part RAMSES 741/748	9070602
	<b>Central part RAMSES 746</b> - Central part with switch section and setting button	- RAMSES 746	Central part RAMSES 746	9070601
	<b>Power unit CO<sub>2</sub>-sensor</b> - 24 V/12 W flush-mounted power unit (SELV)	- AMUN 716 R	Power unit CO <sub>2</sub> -sensor	9070494
	<b>Mast mounting S</b> - For mast or corner installation of max. 2 weather stations Meteodata, LUXOR or LUNA - Diameter 48–60 mm	- LUXOR 440 - LUXORliving M140 - Meteodata KNX - LUNA 131 S KNX - LUNA 133 KNX	Mast mounting S	9070928
	<b>GSM cable PHARAO-II</b> - PHARAO-II GSM interface cable - Enables connection to be established and SMS data to be transmitted to mobile telephone, email address or fax machine. The interface for connecting the GSM cable is located below the plug-in upgrade modules.	- PHARAO-II	GSM cable PHARAO-II	9070329
	<b>Memory module PHARAO-II</b> - Plug-in EEPROM memory module (5 kByte) - External memory module for transferring and/or downloading the program from or to the internal EEPROM system memory. Internal program is deactivated for as long as the external memory module is plugged in (dual programming).	- PHARAO-II	Memory module PHARAO-II	9070328
	<b>Power unit 24 V DC</b> - Power pack for supply voltage from PHARAO controllers and sensors. Power unit sufficient for 5 x PhARAO-II 14/15 or 4 x PHARAO-II 24/25 controls - Width: 3 modules	- LUNA 131 DDC - PHARAO-II	Power unit 24 V DC	9079330
	<b>Programming cable PHARAO</b> - For series connection (RS 232) to enable control programs to be configured and parameterised. This cable is used to connect an analogue model for remote maintenance and remote control.	- PHARAO-II	Programming cable PHARAO	9070252

# Index 2018

## Alphabetical A ... F

Type	Art.-No.	GTIN/EAN	Page
<b>A</b>			
Actuator ALPHA 5 230 V	9070441	4003468901038	344
Actuator ALPHA 5 24 V	9070442	4003468901052	344
Adapter plate LUNA star	9070486	4003468907559	341
Adapter plate RAMSES 70x	9070480	4003468904299	342
Adapter plate RAMSES 714	9070212	4003468900796	343
Adapter RAMSES 72x/78x	9070245	4003468902059	342
AMUN 716 S KNX	7169230	4003468710197	264
AMUN 716 SR	7160110	4003468710173	232
Analogue flush-mounted light sensor	9070011	4003468900604	341
Analogue surface-mounted light sensor	9070416	4003468904275	342
Antenna top2 RC-DCF	9070410	4003468904077	335
Antenna top2 RC-GPS	9070610	4003468903254	335
<b>B</b>			
Bluetooth OBELISK top3	9070130	4003468902639	335
BM 12 T KNX	4940235	4003468490723	254
BM 6 T KNX	4940230	4003468490716	254
BME 6 T KNX	4930235	4003468490242	254
BMG 6 T KNX	4930230	4003468490204	254
BZ 142-1	1420721	4003468140017	68
BZ 142-1 10V	1420821	4003468140420	68
BZ 142-1 230V	1420621	4003468140086	68
BZ 142-1 24V	1424721	4003468140932	68
BZ 142-3	1420723	4003468140024	68
BZ 142-3 10V	1420823	4003468140369	68
BZ 143-1	1430721	4003468140130	68
BZ 145	1450000	4003468140918	68
BZ 145 24V	1459024	4003468141021	68
BZ 145 24V 50HZ	1454000	4003468141045	68
BZ 146	1460000	4003468146002	70
BZ 147	1470000	4003468147009	70
BZ 148	1480000	4003468148006	70
<b>C</b>			
Ceiling installation box 73A	9070917	7612748004979	337
Central part RAMSES 741/748	9070602	4003468904589	345
Central part RAMSES 746	9070601	4003468904572	345
CHEOPS control KNX	7329201	4003468732014	263
CHEOPS drive KNX	7319200	4003468731000	263
Clamp BZ	9070043	4003468900703	336
compact office 24V	2014000	7612748001039	136
compact office 24V Lux	2014001	7612748001121	138
compact office DIM	2010001	7612748000773	114
compact passage	2010090	7612748001626	116
compact passage 24V	2014090	7612748001725	140
compact passage BK	2010806	7612748002746	116
compact passage GST	2010100	4003468200056	118
compact passage KNX	2019290	7612748001732	270
compact passage KNX BK	2019803	7612748002890	270
compact passage KNX SR	2019804	7612748002906	270
compact passage SR	2010807	7612748002753	116
compact passage WINSTA	2010105	4003468200063	118
compact passimo BK	2010809	7612748003361	120
compact passimo KNX BK	2019809	7612748003446	270
compact passimo KNX SR	2019810	7612748003453	270
compact passimo KNX WH	2019280	7612748003439	270
compact passimo SR	2010810	7612748003378	120
compact passimo WH	2010080	7612748003354	120

Type	Art.-No.	GTIN/EAN	Page
Corner angle 10 AL	9070970	4003468901717	340
Corner angle 10 BK	9070987	4003468902110	340
Corner angle 10 WH	9070969	4003468901700	340
Corner angle theLuxa E BK	9070975	4003468900994	339
Corner angle theLuxa E WH	9070974	4003468901939	339
Corner angle theLuxa P BK	9070905	4003468900314	340
Corner angle theLuxa P WH	9070904	4003468900291	340
Corner angle theLuxa S BK	9070903	4003468900284	340
Corner angle theLuxa S WH	9070902	4003468900277	340
Cover 55 x 55 for BZ	9070041	4003468902004	336
Cover 72 x 72 for BZ	9070074	4003468900925	336
Cover frame PresenceLight 180 BK	9070628	7612748001640	337
Cover frame PresenceLight 180 SR	9070627	7612748001664	337
Cover frame PresenceLight 180 WH	9070629	7612748001886	337
Cover frame PresenceLight 360 BK	9070632	7612748001237	336
Cover frame PresenceLight 360 SR	9070631	7612748001251	336
Cover frame PresenceLight 360 WH	9070510	7612748001275	336
<b>D</b>			
DALI-Gateway KNX plus	9070929	4003468902394	295
Digital flush-mounted light sensor	9070456	4003468904343	342
Digital surface-mounted light sensor	9070415	4003468904268	342
DIMAX 532 plus	5320001	4003468530016	80
DIMAX 534 plus	5340001	4003468530009	80
DIMAX 542 plus	5420001	4003468540015	82
DIMAX 544 plus	5440001	4003468540008	82
Diode module	9070367	4003468903605	342
DM 2 T KNX	4940270	4003468490792	248
DM 4 T KNX	4940275	4003468490808	248
DM 4-2 T KNX	4940280	4003468490907	250
DM 8-2 T KNX	4940285	4003468490891	250
DMB 1 T KNX	4930279	4003468490020	248
DME 2 T KNX	4930275	4003468490013	248
DMG 2 T KNX	4930270	4003468490006	248
<b>E</b>			
ECO-IR DUAL-C NT	2020401	7612748000872	126
ELPA 041	0410002	4003468041000	78
ELPA 047	0470002	4003468047002	78
ELPA 1	0010002	4003468010518	74
ELPA 3	0030002	4003468010501	74
ELPA 6	0060002	4003468010525	74
ELPA 6 plus	0060003	4003468000052	74
ELPA 7	0070002	4003468007006	76
ELPA 8	080002	4003468010068	76
ELPA 9	0090001	4003468010129	76
EM 4 top2	6490104	4003468649008	34
EM LAN top2	6490900	4003468649015	34
External temperature sensor 1	9070191	4003468901915	343
External temperature sensor 2	9070192	4003468901922	343
<b>F</b>			
FCA 1 KNX	4920200	4003468492000	266
FCA 2 KNX	4920210	4003468490983	266
Flow temperature sensor RAMSES	9070371	4003468903629	343
Frame RAMSES 74x	9070603	4003468904596	344
FRI 77 g	0770033	4003468070024	62
FRI 77 g-2	0770832	4003468070086	62
FRI 77 h-2	0770802	4003468070048	62
Front kit BZ 142-3	9070075	4003468900932	336

Type	Art.-No.	GTIN/EAN	Page
Front panel kit	9070001	4003468900109	334
<b>G</b>			
GSM cable PHARAO-II	9070329	4003468903483	345
<b>H</b>			
HM 12 T KNX	4940245	4003468490761	260
HM 6 T KNX	4940240	4003468490754	260
HME 6 T KNX	4930245	4003468490198	260
HMG 6 T KNX	4930240	4003468490129	260
HMT 12 S KNX	4900374	4003468491331	262
HMT 6 S KNX	4900373	4003468491324	262
<b>I</b>			
Interface USB KNX	9070397	4003468903995	299
IP Interface KNX	9070981	4003468901991	298
IP Router KNX	9070980	4003468901946	298
<b>J</b>			
JM 4 T 24V KNX	4940260	4003468490877	246
JM 4 T KNX	4940250	4003468490778	244
JM 8 T 24V KNX	4940265	4003468490884	246
JM 8 T KNX	4940255	4003468490785	244
JME 4 T 24V KNX	4930265	4003468490860	246
JME 4 T KNX	4930255	4003468490075	244
JMG 4 T 24V KNX	4930260	4003468490853	246
JMG 4 T KNX	4930250	4003468490051	244
Junction casing, 115 x 115 x 100 mm	9070689	7612748002661	338
<b>K</b>			
KNX-OT-Box S	8559201	4003468850220	296
<b>L</b>			
Light sensor theRolla	9070926	4003468901021	334
Line coupler S KNX	9070880	4003468900253	299
LUNA 108 AL	1080710	4003468108017	86
LUNA 108 EL	1080700	4003468108000	86
LUNA 109 AL	1090100	4003468109007	86
LUNA 109 EL	1090200	4003468109014	86
LUNA 110 AL	1100100	4003468111109	86
LUNA 110 AL 24V	1104100	4003468111161	86
LUNA 110 EL	1100200	4003468111154	86
LUNA 110 EL 24V	1104200	4003468111222	86
LUNA 111 top2 AL	1110100	4003468111147	88
LUNA 111 top2 EL	1110200	4003468111116	88
LUNA 112 top2 AL	1120100	4003468121007	88
LUNA 112 top2 EL	1120200	4003468121014	88
LUNA 120 top2 AL	1200100	4003468120002	90
LUNA 120 top2 EL	1200200	4003468120019	90
LUNA 121 top2 RC AL	1210100	4003468121009	90
LUNA 121 top2 RC AL 24V	1214100	4003468121054	90
LUNA 121 top2 RC EL	1210200	4003468121016	90
LUNA 122 top2 RC AL	1220100	4003468122006	90
LUNA 122 top2 RC EL	1220200	4003468122013	90
LUNA 126 star	1260700	4003468126004	92
LUNA 127 star	1270700	4003468127001	92
LUNA 128 star	1280700	4003468128008	92
LUNA 129 star-time	1290700	4003468129005	92
LUNA 131 DDC	1319700	4003468131022	332
LUNA 131 S KNX	1319201	4003468131039	290
LUNA 133 KNX	1339200	4003468133002	291
LUNA 134 KNX	1349200	4003468130032	289
LUXA 102 FL LED 32W BK	1020776	4003468100202	176

Type	Art.-No.	GTIN/EAN	Page
LUXA 102 FL LED 32W WH	1020775	4003468100196	176
LUXA 102-180 LED 32W BK	1020976	4003468100097	174
LUXA 102-180 LED 32W WH	1020975	4003468100080	174
LUXA 103-100 AP WH	1030022	4003468100813	194
LUXA 103-100 C DE WH	1030016	4003468101117	196
LUXA 103-100 DE WH	1030012	4003468100790	194
LUXA 103-100 U WH	1030040	4003468101131	198
LUXA 103-100 UA WH	1030045	4003468101148	198
LUXA 103-101 AP WH	1030023	4003468100820	194
LUXA 103-101 C DE WH	1030017	4003468101124	196
LUXA 103-101 DE WH	1030013	4003468100806	194
LUXA 103-200	1030030	4003468103043	200
LUXA 103-200 T	1030031	4003468103050	200
LUXOR 400	4000000	4003468400005	318
LUXOR 402	4020000	4003468402009	318
LUXOR 404	4040000	4003468404003	318
LUXOR 405 S	4050100	4003468400043	320
LUXOR 408 S	4080100	4003468408032	321
LUXOR 409 S	4090100	4003468409039	321
LUXOR 411	4110000	4003468411001	322
LUXOR 414	4140000	4003468414002	326
LUXOR 426	4260000	4003468426005	324
LUXOR 440	4400000	4003468440001	322
LUXOR Set 4	4990004	4003468499047	327
LUXOR Set 5	4990005	4003468499054	327
LUXORliving B6	4800430	4003468480106	310
LUXORliving D2	4800470	4003468480045	308
LUXORliving D4	4800475	4003468480052	308
LUXORliving H6	4800440	4003468480090	312
LUXORliving IP1	4800495	4003468480168	315
LUXORliving J4	4800450	4003468480083	309
LUXORliving J8	4800455	4003468480076	309
LUXORliving M140	4800490	4003468480113	314
LUXORliving P640	4800990	4003468480007	316
LUXORliving R718	4800480	4003468480120	313
LUXORliving S16	4800429	4003468480038	306
LUXORliving S4	4800420	4003468480021	306
LUXORliving S8	4800425	4003468480014	306
LUXORliving set drives	4990010	4003468491348	317
LUXORliving set drives & lighting	4990012	4003468491362	317
LUXORliving set lighting	4990011	4003468491355	317
LUXORliving T2	4800402	4003468480137	311
LUXORliving T4	4800404	4003468480144	311
LUXORliving T8	4800408	4003468480151	311
<b>M</b>			
Masking clip	9070921	7612748005495	337
Mast mounting S	9070928	4003468901687	345
MEM 190 a	1900001	4003468190050	48
Memory card OBELISK top2	9070404	4003468904053	335
Memory module PHARAO-II	9070328	4003468903414	345
Meteodata 139 KNX	1399200	4003468130001	288
Meteodata 140 basic KNX	1409205	4003468140000	286
Meteodata 140 S 24V GPS KNX	1409204	4003468140048	286
Meteodata 140 S 24V KNX	1409201	4003468140031	286
Meteodata 140 S GPS KNX	1409208	4003468140062	286
Meteodata 140 S KNX	1409207	4003468140055	286
Multiple contact strip	9075141	4003468904688	334

# Index 2018

## Alphabetical O ... R

Type	Art.-No.	GTIN/EAN	Page
<b>O</b>			
OSIRIA 220 AR KNX	5009200	4003468500057	300
OSIRIA 230 AR KNX	5009210	4003468500071	300
OSIRIA 230 SR KNX	5009211	4003468500088	300
OSIRIA 232 BQ KNX	5009223	4003468500293	301
OSIRIA 240 AR KNX	5009230	4003468500132	300
OSIRIA 240 SR KNX	5009231	4003468500149	300
OSIRIA 241 AR KNX	5009240	4003468500170	300
OSIRIA 241 BR KNX	5009241	4003468500187	300
OSIRIA 242 AR KNX	5009250	4003468500194	301
OSIRIA 242 SR KNX	5009251	4003468500200	301
OSIRIA 251 BQ KNX	5009252	4003468500279	301
OT-Box Standard	9070712	4003468904763	343
Outside temperature sensor	9070463	4003468900871	343
<b>P</b>			
PC set OBELISK top2/3	9070409	4003468904015	335
PHARAO-II 10 (AC)	5750210	4003468575185	330
PHARAO-II 11 (DC)	5759211	4003468575192	330
PHARAO-II 14 (AC)	5750014	4003468575093	330
PHARAO-II 15 (DC)	5759015	4003468575109	330
PHARAO-II 24 (AC)	5750024	4003468575116	330
PHARAO-II 25 (DC)	5759025	4003468575123	330
PHARAO-II extension 4AR (AC)	5759102	4003468575154	330
PlanoBox 1BK	9070732	7612748003880	338
PlanoBox 1EL	9070735	7612748003910	338
PlanoBox 1SR	9070733	7612748003897	338
PlanoBox 1WH	9070731	7612748003873	338
PlanoCentro 000-EWH	2040102	7612748003279	128
PlanoCentro 000-UWH	2040202	7612748003316	128
PlanoCentro 101-EWH	2030102	7612748002456	128
PlanoCentro 101-UWH	2030202	7612748002494	128
PlanoCentro 201-EWH	2030502	7612748003095	130
PlanoCentro 201-UWH	2030602	7612748003132	130
PlanoCentro 300-EWH	2030302	7612748003187	130
PlanoCentro 300-UWH	2030402	7612748003224	130
PlanoCentro EWH PCLON	2069102	7612748003972	152
PlanoCentro EWH-A KNX	2059102	7612748003644	152
PlanoCentro UWH PCLON	2069202	7612748004016	152
PlanoCentro UWH-A KNX	2059202	7612748003682	152
PlanoCover 112x112 EBK	9070678	7612748002555	338
PlanoCover 112x112 ESR	9070679	7612748002562	338
PlanoCover 112x112 EWH	9070677	7612748002548	338
PlanoCover 123x123 UBK	9070681	7612748002586	338
PlanoCover 123x123 USR	9070682	7612748002593	338
PlanoCover 123x123 UWH	9070680	7612748002579	338
PlanoCover 76 BK	9070977	7612748006140	338
PlanoCover 76 SR	9070978	7612748006157	338
PlanoCover 76 WH	9070976	7612748006133	338
PlanoSet RQ EBK	9070737	7612748004702	338
PlanoSet RQ ESR	9070738	7612748004719	338
PlanoSet RQ EWH	9070736	7612748004696	338
PlanoSet RR EBK	9070741	7612748004665	338
PlanoSet RR ESR	9070742	7612748004672	338
PlanoSet RR EWH	9070740	7612748004658	338
PlanoSpot 360 DALI DE WH	2030110	7612748004931	146
PlanoSpot 360 KNX DE WH	2039100	7612748005839	278

Type	Art.-No.	GTIN/EAN	Page
PlanoSpot 360 KNX S DE WH	2039300	7612748006270	278
PlanoSpot 360 PSLON DE WH	2039200	7612748005884	150
Plug-in socket BZ	9070042	4003468900697	336
Plunge sensor RAMSES	9070379	4003468903711	344
Power unit 24 V DC	9079330	4003468903520	345
Power unit CO2-sensor	9070494	4003468904534	345
Power unit top2 GPS	9070892	4003468904718	336
PresenceLight 180	2000050	7612748001602	134
PresenceLight 180 PLLON WH	2009150	7612748004863	154
PresenceLight 180B-KNX WH	2009050	7612748003835	282
PresenceLight 360	2000000	7612748001107	96
PresenceLight 360 PLLON WH	2009100	7612748004825	148
PresenceLight 360B-KNX WH	2009000	7612748003750	268
Programming cable PHARAO	9070252	4003468902851	345
PS 160 mA T KNX	9070956	4003468902271	297
PS 320 mA T KNX	9070957	4003468902288	297
PS 640 mA T KNX	9070958	4003468902295	297
<b>Q</b>			
QuickSafe	9070531	7612748000582	338
<b>R</b>			
RAMSES 366/1 top2	3660100	4003468360026	212
RAMSES 701	7010001	4003468701140	224
RAMSES 702	7020001	4003468702055	224
RAMSES 703	7030001	4003468703052	224
RAMSES 704	7040001	4003468704028	224
RAMSES 705	7050001	4003468705032	224
RAMSES 706	7060001	4003468706022	224
RAMSES 707	7070001	4003468707029	224
RAMSES 708	7080001	4003468708026	224
RAMSES 709	7090001	4003468709030	224
RAMSES 713 FC KNX	7139202	4003468713020	265
RAMSES 714	7140002	4003468714126	228
RAMSES 714 A	7140016	4003468714133	228
RAMSES 718 P KNX	7189210	4003468710210	258
RAMSES 718 S KNX	7189200	4003468710203	259
RAMSES 721	7210030	4003468721018	220
RAMSES 722	7220030	4003468722015	220
RAMSES 722 S	7220801	4003468722022	218
RAMSES 725	7250030	4003468725016	220
RAMSES 741	7410130	4003468741023	226
RAMSES 741 RA	7410131	4003468741030	226
RAMSES 746	7460130	4003468746028	226
RAMSES 746 RA	7460131	4003468746035	226
RAMSES 748	7480130	4003468748022	226
RAMSES 748 RA	7480131	4003468748039	226
RAMSES 751 RA	7510131	4003468751008	228
RAMSES 782	7820030	4003468782019	220
RAMSES 784	7840030	4003468784013	220
RAMSES 784 S	7840801	4003468784020	218
RAMSES 811 top2	8119132	4003468811139	204
RAMSES 812 top2	8120132	4003468812037	206
RAMSES 813 top2 HF Set 1	8139501	4003468813218	208
RAMSES 813 top2 HF Set A	8139503	4003468813164	208
RAMSES 816 top2 OT	8169132	4003468810002	214
RAMSES 831 top2	8319132	4003468831052	204
RAMSES 832 top2	8320132	4003468832035	206

Type	Art.-No.	GTIN/EAN	Page
RAMSES 833 top2 HF Set 1	8339501	4003468833049	210
RAMSES 833 top2 HF Set 2	8339502	4003468833056	210
RAMSES 856 top2 OT	8569132	4003468850084	216
RC filter	9070523	7612748001701	339
RM 16 S KNX	4940225	4003468491256	240
RM 16 T KNX	4940205	4003468490846	242
RM 4 I KNX	4940210	4003468490297	238
RM 4 U KNX	4940223	4003468490976	236
RM 8 I KNX	4940215	4003468490303	238
RM 8 S KNX	4940220	4003468490990	240
RM 8 T KNX	4940200	4003468490839	242
RME 4 I KNX	4930215	4003468493090	238
RME 4 U KNX	4930228	4003468490952	236
RME 8 S KNX	4930225	4003468493076	240
RME 8 T KNX	4930205	4003468490822	242
RMG 4 I KNX	4930210	4003468493083	238
RMG 4 U KNX	4930223	4003468490969	236
RMG 8 S KNX	4930220	4003468493069	240
RMG 8 T KNX	4930200	4003468490815	242
<b>S</b>			
SELEKTA 170 top2 24V	1704100	4003468170564	30
SELEKTA 170 top3	1700130	4003468170120	30
SELEKTA 171 top2 RC	1710100	4003468171004	30
SELEKTA 171 top2 RC 24V	1714100	4003468171035	30
SELEKTA 172 top2	1720100	4003468172001	30
SELEKTA 172 top2 24V	1724100	4003468172056	30
SELEKTA 174 top3	1740130	4003468170137	30
SELEKTA 175 top2	1750100	4003468100424	36
SendoPro 868-A	9070675	7612748002524	339
SME 2 S KNX	4910274	4003468491744	252
SMG 2 S KNX	4910273	4003468491737	252
Snap-on mounting 72 x 72	9070071	4003468900895	334
Socket RAMSES	9070605	4003468904657	342
SOTHIS 715	7150002	4003468715024	233
Spacer 10 AL	9070972	4003468901830	340
Spacer 10 BK	9070988	4003468902707	340
Spacer 10 WH	9070971	4003468901724	340
Spacer theLuxe P BK	9070909	4003468900420	339
Spacer theLuxe P WH	9070908	4003468900413	339
Spacer theLuxe S BK	9070907	4003468900345	339
Spacer theLuxe S WH	9070906	4003468900338	339
SPHINX 104-360	1040370	4003468104026	100
SPHINX 104-360 AP	1040360	4003468104002	100
SPHINX 104-360/2	1040372	4003468104033	100
SPHINX 104-360/2 AP	1040362	4003468104019	100
SPHINX 104-360/2 DIMplus	1040374	4003468104040	102
SPHINX RC 104	9070538	4003468904428	341
SPHINX RC 104 Pro	9070536	4003468904404	341
SUD 228 II	2280577	4003468228012	332
SUL 180 a	1800001	4003468183311	48
SUL 181 d	1810011	4003468182383	50
SUL 181 d 24V	1814011	4003468180105	50
SUL 188 g	1880033	4003468181003	52
SUL 188 hw	1880108	4003468181010	52
SUL 189 hw	1890108	4003468181164	58
SUL 189 s	1890801	4003468180631	54

Type	Art.-No.	GTIN/EAN	Page
SUL 189 s 110V	1891801	4003468182093	54
SUL 191 w	1910011	4003468191040	50
SUL 285/2 T	2850033	4003468285022	60
SUL 289 g	2890033	4003468280096	56
SUL 289 h	2890008	4003468280089	56
Surface frame 110A GR	9070913	7612748004917	337
Surface frame 110A WH	9070912	7612748004900	337
Surface frame 110B GR	9070919	7612748005471	337
Surface frame 110B WH	9070918	7612748005464	337
Surface frame 75A BK	9070950	7612748005938	337
Surface frame 75A SR	9070951	7612748005945	337
Surface frame 75A WH	9070949	7612748005921	337
Surface frame compact	9070514	7612748000711	337
Surface frame compact BK	9070637	7612748001329	337
Surface frame compact SR	9070638	7612748001343	337
Surface frame LUXA 103-100 U	9070986	4003468902080	341
Surface frame LUXA 103-200	9070504	4003468904367	341
Surface frame PresenceLight	9070513	7612748001145	336
Surface frame PresenceLight BK	9070634	7612748001176	336
Surface frame PresenceLight SR	9070635	7612748001190	336
Surface-mounted light sensor	9070008	4003468900574	342
SYN 151 h	1510011	4003468151006	50
SYN 160 a	1600001	4003468161609	48
SYN 161 d	1610011	4003468161371	50
SYN 169 s	1690801	4003468160633	54
SYN 269 h	2690008	4003468260012	56
<b>T</b>			
TA 2 S KNX	4969222	4003468491263	256
TA 4 S KNX	4969224	4003468491270	256
TA 6 S KNX	4969226	4003468491287	256
TA 8 S KNX	4969228	4003468491294	256
Temperature sensor	9070321	4003468903360	343
Temperature sensor RAMSES IP 65	9070459	4003468903810	343
Terminal cover 52,5 mm	9070061	4003468900802	334
theben-eltimo 020 S	0200000	4003468022313	44
theben-eltimo 020 S DCF	0200300	4003468024034	44
theben-timer 26	0260030	4003468020821	61
theben-timer 26 IP 44	0260855	4003468020166	61
theben-timer 27	0270930	4003468020869	61
theLeda E10 BK	1020912	4003468100448	168
theLeda E10 WH	1020911	4003468100431	168
theLeda E10L BK	1020712	4003468100103	170
theLeda E10L WH	1020711	4003468100516	170
theLeda E20 BK	1020914	4003468100462	168
theLeda E20 WH	1020913	4003468100455	168
theLeda E20L BK	1020714	4003468100493	170
theLeda E20L WH	1020713	4003468100523	170
theLeda E30 BK	1020916	4003468100486	168
theLeda E30 WH	1020915	4003468100479	168
theLeda E30L BK	1020716	4003468100509	170
theLeda E30L WH	1020715	4003468100530	170
theLeda P12 AL	1020942	4003468100684	178
theLeda P12 WH	1020941	4003468100677	178
theLeda P12L AL	1020742	4003468100646	180
theLeda P12L WH	1020741	4003468100639	180
theLeda P24 AL	1020944	4003468100707	178

# Index 2018

## Alphabetical T ... T

Type	Art.-No.	GTIN/EAN	Page
theLeda P24 WH	1020943	4003468100691	178
theLeda P24L AL	1020744	4003468100660	180
theLeda P24L WH	1020743	4003468100653	180
theLeda S10 BK	1020922	4003468100899	172
theLeda S10 W BK	1020932	4003468100936	172
theLeda S10 W WH	1020931	4003468100929	172
theLeda S10 WH	1020921	4003468100882	172
theLeda S10L BK	1020722	4003468100851	176
theLeda S10L WH	1020721	4003468100837	176
theLeda S20 BK	1020924	4003468100912	172
theLeda S20 W BK	1020934	4003468100950	172
theLeda S20 W WH	1020933	4003468100943	172
theLeda S20 WH	1020923	4003468100905	172
theLeda S20L BK	1020724	4003468100875	176
theLeda S20L WH	1020723	4003468100868	176
theLuxa E180 BK	1010206	4003468100721	158
theLuxa E180 WH	1010205	4003468100714	158
theLuxa P220 BK	1010606	4003468100318	166
theLuxa P220 WH	1010605	4003468100288	166
theLuxa P300 BK	1010611	4003468100356	166
theLuxa P300 KNX BK	1019611	4003468100387	284
theLuxa P300 KNX WH	1019610	4003468100370	284
theLuxa P300 WH	1010610	4003468100332	166
theLuxa R180 BK	1010201	4003468100783	160
theLuxa R180 WH	1010200	4003468100776	160
theLuxa S150 BK	1010501	4003468100226	162
theLuxa S150 WH	1010500	4003468100219	162
theLuxa S180 BK	1010506	4003468100257	162
theLuxa S180 WH	1010505	4003468100240	162
theLuxa S360 BK	1010511	4003468100271	164
theLuxa S360 WH	1010510	4003468100264	164
theMova P360-100 UP GR	1030601	7612748005112	190
theMova P360-100 UP WH	1030600	7612748005105	190
theMova P360-100 WH GST	1030610	4003468100752	192
theMova P360-100 WH WINSTA	1030615	4003468100769	192
theMova S360-100 AP GR	1030551	7612748005020	186
theMova S360-100 AP WH	1030550	7612748005013	186
theMova S360-100 DE GR	1030561	7612748004993	184
theMova S360-100 DE WH	1030560	7612748004986	184
theMova S360-100 WH GST	1030570	4003468100738	188
theMova S360-100 WH WINSTA	1030575	4003468100745	188
theMova S360-101 AP GR	1030556	7612748005082	186
theMova S360-101 AP WH	1030555	7612748005075	186
theMova S360-101 DE GR	1030566	7612748005051	184
theMova S360-101 DE WH	1030565	7612748005044	184
thePiccola P360-100 DE WH	2090200	4003468200001	98
thePiccola S360-100 DE WH	1060200	4003468100622	182
thePrema P360 KNX UP GR	2079001	7612748004467	276
thePrema P360 KNX UP WH	2079000	7612748004450	276
thePrema P360 Slave E UP GR	2070131	7612748005631	124
thePrema P360 Slave E UP WH	2070130	7612748005624	124
thePrema P360-101 E UP GR	2070106	7612748005549	124
thePrema P360-101 E UP WH	2070105	7612748005532	124
thePrema S360 DALI UP GR	2070526	7612748004627	142
thePrema S360 DALI UP WH	2070525	7612748004610	142
thePrema S360 KNX UP GR	2079501	7612748004504	276
thePrema S360 KNX UP WH	2079500	7612748004498	276

Type	Art.-No.	GTIN/EAN	Page
thePrema S360 Slave E UP GR	2070631	7612748005662	122
thePrema S360 Slave E UP WH	2070630	7612748005655	122
thePrema S360-100 E UP GR	2070601	7612748005600	122
thePrema S360-100 E UP WH	2070600	7612748005594	122
thePrema S360-101 E UP GR	2070606	7612748005570	122
thePrema S360-101 E UP WH	2070605	7612748005563	122
theRolla P032	0320100	4003468030110	42
theRolla S031	0310100	4003468030004	42
theRonda P360 KNX UP GR	2089001	7612748005440	274
theRonda P360 KNX UP WH	2089000	7612748005433	274
theRonda P360 Slave UP GR	2080031	7612748006126	110
theRonda P360 Slave UP WH	2080030	7612748006119	110
theRonda P360-100 M UP GR	2080021	7612748006188	110
theRonda P360-100 M UP WH	2080020	7612748006171	110
theRonda P360-100 UP WINSTA	2080015	4003468200025	112
theRonda P360-100 WH GST	2080010	4003468200018	112
theRonda P360-101 M UP GR	2080026	7612748006218	110
theRonda P360-101 M UP WH	2080025	7612748006201	110
theRonda P360-110 DALI UP	2080040	7612748006348	144
theRonda P360-110 DALI UP	2080041	7612748006355	144
theRonda P360-330 DALI UP	2080045	7612748006317	144
theRonda P360-330 DALI UP	2080046	7612748006324	144
theRonda S360 KNX AP GR	2089551	7612748006454	272
theRonda S360 KNX AP WH	2089550	7612748006447	272
theRonda S360 KNX FLAT DE GR	2089561	7612748006423	272
theRonda S360 KNX FLAT DE WH	2089560	7612748006416	272
theRonda S360-100 AP GR	2080551	7612748005976	106
theRonda S360-100 AP WH	2080550	7612748005969	106
theRonda S360-100 DE GR	2080561	7612748006034	104
theRonda S360-100 DE WH	2080560	7612748006027	104
theRonda S360-100 WH GST	2080570	4003468200032	108
theRonda S360-100 WH WINSTA	2080575	4003468200049	108
theRonda S360-101 AP GR	2080556	7612748006003	106
theRonda S360-101 AP WH	2080555	7612748005990	106
theRonda S360-101 DE GR	2080566	7612748006065	104
theRonda S360-101 DE WH	2080565	7612748006058	104
theRonda S360-110 DALI UP	2080580	7612748006379	144
theRonda S360-110 DALI UP	2080581	7612748006386	144
theSenda P	9070910	4003468900475	341
theSenda S	9070911	4003468900505	341
theServa S110	8254100	4003468820070	302
TM 179 h	1790008	4003468170151	58
TM 345 B	3450730	4003468340103	66
TM 345 M	3450731	4003468340110	66
TR 608 top2 S	6080101	4003468600115	36
TR 609 top2 S	6090101	4003468600122	36
TR 610 top2 24V	6104100	4003468613009	26
TR 610 top2 G	6100110	4003468612590	26
TR 610 top3	6100130	4003468610299	26
TR 611 top2	6110103	4003468612071	28
TR 611 top2 24V	6114100	4003468613016	28
TR 611 top2 RC	6110300	4003468611838	28
TR 611 top2 RC 24V	6114300	4003468612231	28
TR 612 top2 24V	6124100	4003468613023	26
TR 612 top3	6120130	4003468610305	26
TR 622 top2	6220103	4003468612170	28
TR 622 top2 24V	6224100	4003468613030	28

Type	Art.-No.	GTIN/EAN	Page
TR 635 top2	6350100	4003468630006	38
TR 636 top2	6360100	4003468630020	38
TR 641 top2	6410100	4003468641088	32
TR 641 top2 RC	6410300	4003468641118	32
TR 641 top2 RC 24V	6414300	4003468641125	32
TR 642 top2	6420100	4003468642085	32
TR 642 top2 RC	6420300	4003468642108	32
TR 642 top2 RC 24V	6424300	4003468642115	32
TR 644 top2	6440100	4003468644232	32
TR 644 top2 RC	6440300	4003468644218	32
TR 648 top2 RC KNX	6489212	4003468640012	292
TR 648 top2 RC-DCF KNX	6489210	4003468640005	292
TR 684-1 top2	6840100	4003468680254	40
TR 684-2 top2	6840101	4003468680261	40
<b>V</b>			
Valve adapter VA 78	9070436	4003468904220	344
Valve adapter VA 80	9070437	4003468904237	344
VARIA 826 S BK KNX	8269211	4003468820056	257
VARIA 826 S WH KNX	8269210	4003468820049	257
<b>W</b>			
Wall mounting kit 17,5 mm	9070065	4003468900833	334
Wall mounting kit 35 mm	9070064	4003468900826	334
Wall mounting kit 52,5 mm	9070050	4003468900734	334
Wall mounting kit 70 mm	9070049	4003468900727	334
<b>Z</b>			
ZS 600 DCF KNX	6009200	4003468600009	294

# Index 2018

## Numerical 0010002 ... 1120100

Art.-No.	Type	GTIN/EAN	Page
0010002	ELPA 1	4003468010518	74
0030002	ELPA 3	4003468010501	74
0060002	ELPA 6	4003468010525	74
0060003	ELPA 6 plus	4003468000052	74
0070002	ELPA 7	4003468007006	76
0080002	ELPA 8	4003468010068	76
0090001	ELPA 9	4003468010129	76
0200000	theben-eltimo 020 S	4003468022313	44
0200300	theben-eltimo 020 S DCF	4003468024034	44
0260030	theben-timer 26	4003468020821	61
0260855	theben-timer 26 IP 44	4003468020166	61
0270930	theben-timer 27	4003468020869	61
0310100	theRolla S031	4003468030004	42
0320100	theRolla P032	4003468030110	42
0410002	ELPA 041	4003468041000	78
0470002	ELPA 047	4003468047002	78
0770033	FRI 77 g	4003468070024	62
0770802	FRI 77 h-2	4003468070048	62
0770832	FRI 77 g-2	4003468070086	62
1010200	theLuxa R180 WH	4003468100776	160
1010201	theLuxa R180 BK	4003468100783	160
1010205	theLuxa E180 WH	4003468100714	158
1010206	theLuxa E180 BK	4003468100721	158
1010500	theLuxa S150 WH	4003468100219	162
1010501	theLuxa S150 BK	4003468100226	162
1010505	theLuxa S180 WH	4003468100240	162
1010506	theLuxa S180 BK	4003468100257	162
1010510	theLuxa S360 WH	4003468100264	164
1010511	theLuxa S360 BK	4003468100271	164
1010605	theLuxa P220 WH	4003468100288	166
1010606	theLuxa P220 BK	4003468100318	166
1010610	theLuxa P300 WH	4003468100332	166
1010611	theLuxa P300 BK	4003468100356	166
1019610	theLuxa P300 KNX WH	4003468100370	284
1019611	theLuxa P300 KNX BK	4003468100387	284
1020711	theLeda E10L WH	4003468100516	170
1020712	theLeda E10L BK	4003468100103	170
1020713	theLeda E20L WH	4003468100523	170
1020714	theLeda E20L BK	4003468100493	170
1020715	theLeda E30L WH	4003468100530	170
1020716	theLeda E30L BK	4003468100509	170
1020721	theLeda S10L WH	4003468100837	176
1020722	theLeda S10L BK	4003468100851	176
1020723	theLeda S20L WH	4003468100868	176
1020724	theLeda S20L BK	4003468100875	176
1020741	theLeda P12L WH	4003468100639	180
1020742	theLeda P12L AL	4003468100646	180
1020743	theLeda P24L WH	4003468100653	180
1020744	theLeda P24L AL	4003468100660	180
1020775	LUXA 102 FL LED 32W WH	4003468100196	176
1020776	LUXA 102 FL LED 32W BK	4003468100202	176
1020911	theLeda E10 WH	4003468100431	168
1020912	theLeda E10 BK	4003468100448	168
1020913	theLeda E20 WH	4003468100455	168
1020914	theLeda E20 BK	4003468100462	168
1020915	theLeda E30 WH	4003468100479	168

Art.-No.	Type	GTIN/EAN	Page
1020916	theLeda E30 BK	4003468100486	168
1020921	theLeda S10 WH	4003468100882	172
1020922	theLeda S10 BK	4003468100899	172
1020923	theLeda S20 WH	4003468100905	172
1020924	theLeda S20 BK	4003468100912	172
1020931	theLeda S10 W WH	4003468100929	172
1020932	theLeda S10 W BK	4003468100936	172
1020933	theLeda S20 W WH	4003468100943	172
1020934	theLeda S20 W BK	4003468100950	172
1020941	theLeda P12 WH	4003468100677	178
1020942	theLeda P12 AL	4003468100684	178
1020943	theLeda P24 WH	4003468100691	178
1020944	theLeda P24 AL	4003468100707	178
1020975	LUXA 102-180 LED 32W WH	4003468100080	174
1020976	LUXA 102-180 LED 32W BK	4003468100097	174
1030012	LUXA 103-100 DE WH	4003468100790	194
1030013	LUXA 103-101 DE WH	4003468100806	194
1030016	LUXA 103-100 C DE WH	4003468101117	196
1030017	LUXA 103-101 C DE WH	4003468101124	196
1030022	LUXA 103-100 AP WH	4003468100813	194
1030023	LUXA 103-101 AP WH	4003468100820	194
1030030	LUXA 103-200	4003468103043	200
1030031	LUXA 103-200 T	4003468103050	200
1030040	LUXA 103-100 U WH	4003468101131	198
1030045	LUXA 103-100 UA WH	4003468101148	198
1030550	theMova S360-100 AP WH	7612748005013	186
1030551	theMova S360-100 AP GR	7612748005020	186
1030555	theMova S360-101 AP WH	7612748005075	186
1030556	theMova S360-101 AP GR	7612748005082	186
1030560	theMova S360-100 DE WH	7612748004986	184
1030561	theMova S360-100 DE GR	7612748004993	184
1030565	theMova S360-101 DE WH	7612748005044	184
1030566	theMova S360-101 DE GR	7612748005051	184
1030570	theMova S360-100 WH GST	4003468100738	188
1030575	theMova S360-100 WH WINSTA	4003468100745	188
1030600	theMova P360-100 UP WH	7612748005105	190
1030601	theMova P360-100 UP GR	7612748005112	190
1030610	theMova P360-100 WH GST	4003468100752	192
1030615	theMova P360-100 WH WINSTA	4003468100769	192
1040360	SPHINX 104-360 AP	4003468104002	100
1040362	SPHINX 104-360/2 AP	4003468104019	100
1040370	SPHINX 104-360	4003468104026	100
1040372	SPHINX 104-360/2	4003468104033	100
1040374	SPHINX 104-360/2 DIMplus	4003468104040	102
1060200	thePiccola S360-100 DE WH	4003468100622	182
1080700	LUNA 108 EL	4003468108000	86
1080710	LUNA 108 AL	4003468108017	86
1090100	LUNA 109 AL	4003468109007	86
1090200	LUNA 109 EL	4003468109014	86
1100100	LUNA 110 AL	4003468111109	86
1100200	LUNA 110 EL	4003468111154	86
1104100	LUNA 110 AL 24V	4003468111161	86
1104200	LUNA 110 EL 24V	4003468111222	86
1110100	LUNA 111 top2 AL	4003468111147	88
1110200	LUNA 111 top2 EL	4003468111116	88
1120100	LUNA 112 top2 AL	4003468112007	88

Art.-No.	Type	GTIN/EAN	Page
1120200	LUNA 112 top2 EL	4003468112014	88
1200100	LUNA 120 top2 AL	4003468120002	90
1200200	LUNA 120 top2 EL	4003468120019	90
1210100	LUNA 121 top2 RC AL	4003468121009	90
1210200	LUNA 121 top2 RC EL	4003468121016	90
1214100	LUNA 121 top2 RC AL 24V	4003468121054	90
1220100	LUNA 122 top2 RC AL	4003468122006	90
1220200	LUNA 122 top2 RC EL	4003468122013	90
1260700	LUNA 126 star	4003468126004	92
1270700	LUNA 127 star	4003468127001	92
1280700	LUNA 128 star	4003468128008	92
1290700	LUNA 129 star-time	4003468129005	92
1319201	LUNA 131 S KNX	4003468131039	290
1319700	LUNA 131 DDC	4003468131022	332
1339200	LUNA 133 KNX	4003468133002	291
1349200	LUNA 134 KNX	4003468130032	289
1399200	Meteodata 139 KNX	4003468130001	288
1409201	Meteodata 140 S 24V KNX	4003468140031	286
1409204	Meteodata 140 S 24V GPS KNX	4003468140048	286
1409205	Meteodata 140 basic KNX	4003468140000	286
1409207	Meteodata 140 S KNX	4003468140055	286
1409208	Meteodata 140 S GPS KNX	4003468140062	286
1420621	BZ 142-1 230V	4003468140086	68
1420721	BZ 142-1	4003468140017	68
1420723	BZ 142-3	4003468140024	68
1420821	BZ 142-1 10V	4003468140420	68
1420823	BZ 142-3 10V	4003468140369	68
1424721	BZ 142-1 24V	4003468140932	68
1430721	BZ 143-1	4003468140130	68
1450000	BZ 145	4003468140918	68
1454000	BZ 145 24V 50HZ	4003468141045	68
1459024	BZ 145 24V	4003468141021	68
1460000	BZ 146	4003468146002	70
1470000	BZ 147	4003468147009	70
1480000	BZ 148	4003468148006	70
1510011	SYN 151 h	4003468151006	50
1600001	SYN 160 a	4003468161609	48
1610011	SYN 161 d	4003468161371	50
1690801	SYN 169 s	4003468160633	54
1700130	SELEKTA 170 top3	4003468170120	30
1704100	SELEKTA 170 top2 24V	4003468170564	30
1710100	SELEKTA 171 top2 RC	4003468171004	30
1714100	SELEKTA 171 top2 RC 24V	4003468171035	30
1720100	SELEKTA 172 top2	4003468172001	30
1724100	SELEKTA 172 top2 24V	4003468172056	30
1740130	SELEKTA 174 top3	4003468170137	30
1750100	SELEKTA 175 top2	4003468100424	36
1790008	TM 179 h	4003468170151	58
1800001	SUL 180 a	4003468183311	48
1810011	SUL 181 d	4003468182383	50
1814011	SUL 181 d 24V	4003468180105	50
1880033	SUL 188 g	4003468181003	52
1880108	SUL 188 hw	4003468181010	52
1890108	SUL 189 hw	4003468181164	58
1890801	SUL 189 s	4003468180631	54
1891801	SUL 189 s 110V	4003468182093	54

Art.-No.	Type	GTIN/EAN	Page
1900001	MEM 190 a	4003468190050	48
1910011	SUL 191 w	4003468191040	50
2000000	PresenceLight 360	7612748001107	96
2000050	PresenceLight 180	7612748001602	134
2009000	PresenceLight 360B-KNX WH	7612748003750	268
2009050	PresenceLight 180B-KNX WH	7612748003835	282
2009100	PresenceLight 360 PLLON WH	7612748004825	148
2009150	PresenceLight 180 PLLON WH	7612748004863	154
2010001	compact office DIM	7612748000773	114
2010080	compact passimo WH	7612748003354	120
2010090	compact passage	7612748001626	116
2010100	compact passage GST	4003468200056	118
2010105	compact passage WINSTA	4003468200063	118
2010806	compact passage BK	7612748002746	116
2010807	compact passage SR	7612748002753	116
2010809	compact passimo BK	7612748003361	120
2010810	compact passimo SR	7612748003378	120
2014000	compact office 24V	7612748001039	136
2014001	compact office 24V Lux	7612748001121	138
2014090	compact passage 24V	7612748001725	140
2019280	compact passimo KNX WH	7612748003439	270
2019290	compact passage KNX	7612748001732	270
2019803	compact passage KNX BK	7612748002890	270
2019804	compact passage KNX SR	7612748002906	270
2019809	compact passimo KNX BK	7612748003446	270
2019810	compact passimo KNX SR	7612748003453	270
2020401	ECO-IR DUAL-C NT	7612748000872	126
2030102	PlanoCentro 101-EWH	7612748002456	128
2030110	PlanoSpot 360 DALI DE WH	7612748004931	146
2030202	PlanoCentro 101-UWH	7612748002494	128
2030302	PlanoCentro 300-EWH	7612748003187	130
2030402	PlanoCentro 300-UWH	7612748003224	130
2030502	PlanoCentro 201-EWH	7612748003095	130
2030602	PlanoCentro 201-UWH	7612748003132	130
2039100	PlanoSpot 360 KNX DE WH	7612748005839	278
2039200	PlanoSpot 360 PSLON DE WH	7612748005884	150
2039300	PlanoSpot 360 KNX S DE WH	7612748006270	278
2040102	PlanoCentro 000-EWH	7612748003279	128
2040202	PlanoCentro 000-UWH	7612748003316	128
2059102	PlanoCentro EWH-A KNX	7612748003644	152
2059202	PlanoCentro UWH-A KNX	7612748003682	152
2069102	PlanoCentro EWH PCLON	7612748003972	152
2069202	PlanoCentro UWH PCLON	7612748004016	152
2070105	thePrema P360-101 E UP WH	7612748005532	124
2070106	thePrema P360-101 E UP GR	7612748005549	124
2070130	thePrema P360 Slave E UP WH	7612748005624	124
2070131	thePrema P360 Slave E UP GR	7612748005631	124
2070525	thePrema S360 DALI UP WH	7612748004610	142
2070526	thePrema S360 DALI UP GR	7612748004627	142
2070600	thePrema S360-100 E UP WH	7612748005594	122
2070601	thePrema S360-100 E UP GR	7612748005600	122
2070605	thePrema S360-101 E UP WH	7612748005563	122
2070606	thePrema S360-101 E UP GR	7612748005570	122
2070630	thePrema S360 Slave E UP WH	7612748005655	122
2070631	thePrema S360 Slave E UP GR	7612748005662	122
2079000	thePrema P360 KNX UP WH	7612748004450	276

# Index 2018

## Numerical 2079001 ... 4940275

Art.-No.	Type	GTIN/EAN	Page
2079001	thePrema P360 KNX UP GR	7612748004467	276
2079500	thePrema S360 KNX UP WH	7612748004498	276
2079501	thePrema S360 KNX UP GR	7612748004504	276
2080010	theRonda P360-100 WH GST	4003468200018	112
2080015	theRonda P360-100 UP WINSTA	4003468200025	112
2080020	theRonda P360-100 M UP WH	7612748006171	110
2080021	theRonda P360-100 M UP GR	7612748006188	110
2080025	theRonda P360-101 M UP WH	7612748006201	110
2080026	theRonda P360-101 M UP GR	7612748006218	110
2080030	theRonda P360 Slave UP WH	7612748006119	110
2080031	theRonda P360 Slave UP GR	7612748006126	110
2080040	theRonda P360-110 DALI UP	7612748006348	144
2080041	theRonda P360-110 DALI UP	7612748006355	144
2080045	theRonda P360-330 DALI UP	7612748006317	144
2080046	theRonda P360-330 DALI UP	7612748006324	144
2080550	theRonda S360-100 AP WH	7612748005969	106
2080551	theRonda S360-100 AP GR	7612748005976	106
2080555	theRonda S360-101 AP WH	7612748005990	106
2080556	theRonda S360-101 AP GR	7612748006003	106
2080560	theRonda S360-100 DE WH	7612748006027	104
2080561	theRonda S360-100 DE GR	7612748006034	104
2080565	theRonda S360-101 DE WH	7612748006058	104
2080566	theRonda S360-101 DE GR	7612748006065	104
2080570	theRonda S360-100 WH GST	4003468200032	108
2080575	theRonda S360-100 WH WINSTA	4003468200049	108
2080580	theRonda S360-110 DALI UP	7612748006379	144
2080581	theRonda S360-110 DALI UP	7612748006386	144
2089000	theRonda P360 KNX UP WH	7612748005433	274
2089001	theRonda P360 KNX UP GR	7612748005440	274
2089550	theRonda S360 KNX AP WH	7612748006447	272
2089551	theRonda S360 KNX AP GR	7612748006454	272
2089560	theRonda S360 KNX FLAT DE WH	7612748006416	272
2089561	theRonda S360 KNX FLAT DE GR	7612748006423	272
2090200	thePiccola P360-100 DE WH	4003468200001	98
2280577	SUD 228 II	4003468228012	332
2690008	SYN 269 h	4003468260012	56
2850033	SUL 285/2 T	4003468285022	60
2890008	SUL 289 h	4003468280089	56
2890033	SUL 289 g	4003468280096	56
3450730	TM 345 B	4003468340103	66
3450731	TM 345 M	4003468340110	66
3660100	RAMSES 366/1 top2	4003468360026	212
4000000	LUXOR 400	4003468400005	318
4020000	LUXOR 402	4003468402009	318
4040000	LUXOR 404	4003468404003	318
4050100	LUXOR 405 S	4003468400043	320
4080100	LUXOR 408 S	4003468408032	321
4090100	LUXOR 409 S	4003468409039	321
4110000	LUXOR 411	4003468411001	322
4140000	LUXOR 414	4003468414002	326
4260000	LUXOR 426	4003468426005	324
4400000	LUXOR 440	4003468440001	322
4800402	LUXORliving T2	4003468480137	311
4800404	LUXORliving T4	4003468480144	311
4800408	LUXORliving T8	4003468480151	311

Art.-No.	Type	GTIN/EAN	Page
4800420	LUXORliving S4	4003468480021	306
4800425	LUXORliving S8	4003468480014	306
4800429	LUXORliving S16	4003468480038	306
4800430	LUXORliving B6	4003468480106	310
4800440	LUXORliving H6	4003468480090	312
4800450	LUXORliving J4	4003468480083	309
4800455	LUXORliving J8	4003468480076	309
4800470	LUXORliving D2	4003468480045	308
4800475	LUXORliving D4	4003468480052	308
4800480	LUXORliving R718	4003468480120	313
4800490	LUXORliving M140	4003468480113	314
4800495	LUXORliving IP1	4003468480168	315
4800990	LUXORliving P640	4003468480007	316
4900373	HMT 6 S KNX	4003468491324	262
4900374	HMT 12 S KNX	4003468491331	262
4910273	SMG 2 S KNX	4003468491737	252
4910274	SME 2 S KNX	4003468491744	252
4920200	FCA 1 KNX	4003468492000	266
4920210	FCA 2 KNX	4003468490983	266
4930200	RMG 8 T KNX	4003468490815	242
4930205	RME 8 T KNX	4003468490822	242
4930210	RMG 4 I KNX	4003468493083	238
4930215	RME 4 I KNX	4003468493090	238
4930220	RMG 8 S KNX	4003468493069	240
4930223	RMG 4 U KNX	4003468490969	236
4930225	RME 8 S KNX	4003468493076	240
4930228	RME 4 U KNX	4003468490952	236
4930230	BMG 6 T KNX	4003468490204	254
4930235	BME 6 T KNX	4003468490242	254
4930240	HMG 6 T KNX	4003468490129	260
4930245	HME 6 T KNX	4003468490198	260
4930250	JMG 4 T KNX	4003468490051	244
4930255	JME 4 T KNX	4003468490075	244
4930260	JMG 4 T 24V KNX	4003468490853	246
4930265	JME 4 T 24V KNX	4003468490860	246
4930270	DMG 2 T KNX	4003468490006	248
4930275	DME 2 T KNX	4003468490013	248
4930279	DMB 1 T KNX	4003468490020	248
4940200	RM 8 T KNX	4003468490839	242
4940205	RM 16 T KNX	4003468490846	242
4940210	RM 4 I KNX	4003468490297	238
4940215	RM 8 I KNX	4003468490303	238
4940220	RM 8 S KNX	4003468490990	240
4940223	RM 4 U KNX	4003468490976	236
4940225	RM 16 S KNX	4003468491256	240
4940230	BM 6 T KNX	4003468490716	254
4940235	BM 12 T KNX	4003468490723	254
4940240	HM 6 T KNX	4003468490754	260
4940245	HM 12 T KNX	4003468490761	260
4940250	JM 4 T KNX	4003468490778	244
4940255	JM 8 T KNX	4003468490785	244
4940260	JM 4 T 24V KNX	4003468490877	246
4940265	JM 8 T 24V KNX	4003468490884	246
4940270	DM 2 T KNX	4003468490792	248
4940275	DM 4 T KNX	4003468490808	248

Art.-No.	Type	GTIN/EAN	Page
4940280	DM 4-2 T KNX	4003468490907	250
4940285	DM 8-2 T KNX	4003468490891	250
4969222	TA 2 S KNX	4003468491263	256
4969224	TA 4 S KNX	4003468491270	256
4969226	TA 6 S KNX	4003468491287	256
4969228	TA 8 S KNX	4003468491294	256
4990004	LUXOR Set 4	4003468499047	327
4990005	LUXOR Set 5	4003468499054	327
4990010	LUXORliving set drives	4003468491348	317
4990011	LUXORliving set lighting	4003468491355	317
4990012	LUXORliving set drives & lighting	4003468491362	317
5009200	OSIRIA 220 AR KNX	4003468500057	300
5009210	OSIRIA 230 AR KNX	4003468500071	300
5009211	OSIRIA 230 SR KNX	4003468500088	300
5009223	OSIRIA 232 BQ KNX	4003468500293	301
5009230	OSIRIA 240 AR KNX	4003468500132	300
5009231	OSIRIA 240 SR KNX	4003468500149	300
5009240	OSIRIA 241 AR KNX	4003468500170	300
5009241	OSIRIA 241 BR KNX	4003468500187	300
5009250	OSIRIA 242 AR KNX	4003468500194	301
5009251	OSIRIA 242 SR KNX	4003468500200	301
5009252	OSIRIA 251 BQ KNX	4003468500279	301
5320001	DIMAX 532 plus	4003468530016	80
5340001	DIMAX 534 plus	4003468530009	80
5420001	DIMAX 542 plus	4003468540015	82
5440001	DIMAX 544 plus	4003468540008	82
5750014	PHARAO-II 14 (AC)	4003468575093	330
5750024	PHARAO-II 24 (AC)	4003468575116	330
5750210	PHARAO-II 10 (AC)	4003468575185	330
5759015	PHARAO-II 15 (DC)	4003468575109	330
5759025	PHARAO-II 25 (DC)	4003468575123	330
5759102	PHARAO-II extension 4AR (AC)	4003468575154	330
5759211	PHARAO-II 11 (DC)	4003468575192	330
6009200	ZS 600 DCF KNX	4003468600009	294
6080101	TR 608 top2 S	4003468600115	36
6090101	TR 609 top2 S	4003468600122	36
6100110	TR 610 top2 G	4003468612590	26
6100130	TR 610 top3	4003468610299	26
6104100	TR 610 top2 24V	4003468613009	26
6110103	TR 611 top2	4003468612071	28
6110300	TR 611 top2 RC	4003468611838	28
6114100	TR 611 top2 24V	4003468613016	28
6114300	TR 611 top2 RC 24V	4003468612231	28
6120130	TR 612 top3	4003468610305	26
6124100	TR 612 top2 24V	4003468613023	26
6220103	TR 622 top2	4003468612170	28
6224100	TR 622 top2 24V	4003468613030	28
6350100	TR 635 top2	4003468630006	38
6360100	TR 636 top2	4003468630020	38
6410100	TR 641 top2	4003468641088	32
6410300	TR 641 top2 RC	4003468641118	32
6414300	TR 641 top2 RC 24V	4003468641125	32
6420100	TR 642 top2	4003468642085	32
6420300	TR 642 top2 RC	4003468642108	32
6424300	TR 642 top2 RC 24V	4003468642115	32

Art.-No.	Type	GTIN/EAN	Page
6440100	TR 644 top2	4003468644232	32
6440300	TR 644 top2 RC	4003468644218	32
6489210	TR 648 top2 RC-DCF KNX	4003468640005	292
6489212	TR 648 top2 RC KNX	4003468640012	292
6490104	EM 4 top2	4003468649008	34
6490900	EM LAN top2	4003468649015	34
6840100	TR 684-1 top2	4003468680254	40
6840101	TR 684-2 top2	4003468680261	40
7010001	RAMSES 701	4003468701140	224
7020001	RAMSES 702	4003468702055	224
7030001	RAMSES 703	4003468703052	224
7040001	RAMSES 704	4003468704028	224
7050001	RAMSES 705	4003468705032	224
7060001	RAMSES 706	4003468706022	224
7070001	RAMSES 707	4003468707029	224
7080001	RAMSES 708	4003468708026	224
7090001	RAMSES 709	4003468709030	224
7139202	RAMSES 713 FC KNX	4003468713020	265
7140002	RAMSES 714	4003468714126	228
7140016	RAMSES 714 A	4003468714133	228
7150002	SOTHIS 715	4003468715024	233
7160110	AMUN 716 SR	4003468710173	232
7169230	AMUN 716 S KNX	4003468710197	264
7189200	RAMSES 718 S KNX	4003468710203	259
7189210	RAMSES 718 P KNX	4003468710210	258
7210030	RAMSES 721	4003468721018	220
7220030	RAMSES 722	4003468722015	220
7220801	RAMSES 722 S	4003468722022	218
7250030	RAMSES 725	4003468725016	220
7319200	CHEOPS drive KNX	4003468731000	263
7329201	CHEOPS control KNX	4003468732014	263
7410130	RAMSES 741	4003468741023	226
7410131	RAMSES 741 RA	4003468741030	226
7460130	RAMSES 746	4003468746028	226
7460131	RAMSES 746 RA	4003468746035	226
7480130	RAMSES 748	4003468748022	226
7480131	RAMSES 748 RA	4003468748039	226
7510131	RAMSES 751 RA	4003468751008	228
7820030	RAMSES 782	4003468782019	220
7840030	RAMSES 784	4003468784013	220
7840801	RAMSES 784 S	4003468784020	218
8119132	RAMSES 811 top2	4003468811139	204
8120132	RAMSES 812 top2	4003468812037	206
8139501	RAMSES 813 top2 HF Set 1	4003468813218	208
8139503	RAMSES 813 top2 HF Set A	4003468813164	208
8169132	RAMSES 816 top2 OT	4003468810002	214
8254100	theServa S110	4003468820070	302
8269210	VARIA 826 S WH KNX	4003468820049	257
8269211	VARIA 826 S BK KNX	4003468820056	257
8319132	RAMSES 831 top2	4003468831052	204
8320132	RAMSES 832 top2	4003468832035	206
8339501	RAMSES 833 top2 HF Set 1	4003468833049	210
8339502	RAMSES 833 top2 HF Set 2	4003468833056	210
8559201	KNX-OT-Box S	4003468850220	296
8569132	RAMSES 856 top2 OT	4003468850084	216

# Index 2018

## Numerical 9070001 ... 9070958

Art.-No.	Type	GTIN/EAN	Page
9070001	Front panel kit	4003468900109	334
9070008	Surface-mounted light sensor	4003468900574	342
9070011	Analogue flush-mounted light sensor	4003468900604	341
9070041	Cover 55 x 55 for BZ	4003468902004	336
9070042	Plug-in socket BZ	4003468900697	336
9070043	Clamp BZ	4003468900703	336
9070049	Wall mounting kit 70 mm	4003468900727	334
9070050	Wall mounting kit 52,5 mm	4003468900734	334
9070061	Terminal cover 52,5 mm	4003468900802	334
9070064	Wall mounting kit 35 mm	4003468900826	334
9070065	Wall mounting kit 17,5 mm	4003468900833	334
9070071	Snap-on mounting 72 x 72	4003468900895	334
9070074	Cover 72 x 72 for BZ	4003468900925	336
9070075	Front kit BZ 142-3	4003468900932	336
9070130	Bluetooth OBELISK top3	4003468902639	335
9070191	External temperature sensor 1	4003468901915	343
9070192	External temperature sensor 2	4003468901922	343
9070212	Adapter plate RAMSES 714	4003468900796	343
9070245	Adapter RAMSES 72x/78x	4003468902059	342
9070252	Programming cable PHARAO	4003468902851	345
9070321	Temperature sensor	4003468903360	343
9070328	Memory module PHARAO-II	4003468903414	345
9070329	GSM cable PHARAO-II	4003468903483	345
9070367	Diode module	4003468903605	342
9070371	Flow temperature sensor RAMSES	4003468903629	343
9070379	Plunge sensor RAMSES	4003468903711	344
9070397	Interface USB KNX	4003468903995	299
9070404	Memory card OBELISK top2	4003468904053	335
9070409	PC set OBELISK top2/3	4003468904015	335
9070410	Antenna top2 RC-DCF	4003468904077	335
9070415	Digital surface-mounted light sensor	4003468904268	342
9070416	Analogue surface-mounted light sensor	4003468904275	342
9070436	Valve adapter VA 78	4003468904220	344
9070437	Valve adapter VA 80	4003468904237	344
9070441	Actuator ALPHA 5 230 V	4003468901038	344
9070442	Actuator ALPHA 5 24 V	4003468901052	344
9070456	Digital flush-mounted light sensor	4003468904343	342
9070459	Temperature sensor RAMSES IP 65	4003468903810	343
9070463	Outside temperature sensor	4003468900871	343
9070480	Adapter plate RAMSES 70x	4003468904299	342
9070486	Adapter plate LUNA star	4003468907559	341
9070494	Power unit CO2-sensor	4003468904534	345
9070504	Surface frame LUXA 103-200	4003468904367	341
9070510	Cover frame PresenceLight 360 WH	7612748001275	336
9070513	Surface frame PresenceLight	7612748001145	336
9070514	Surface frame compact	7612748000711	337
9070523	RC filter	7612748001701	339
9070531	QuickSafe	7612748000582	338
9070536	SPHINX RC 104 Pro	4003468904404	341
9070538	SPHINX RC 104	4003468904428	341
9070601	Central part RAMSES 746	4003468904572	345
9070602	Central part RAMSES 741/748	4003468904589	345
9070603	Frame RAMSES 74x	4003468904596	344
9070605	Socket RAMSES	4003468904657	342
9070610	Antenna top2 RC-GPS	4003468903254	335

Art.-No.	Type	GTIN/EAN	Page
9070627	Cover frame PresenceLight 180 SR	7612748001664	337
9070628	Cover frame PresenceLight 180 BK	7612748001640	337
9070629	Cover frame PresenceLight 180 WH	7612748001886	337
9070631	Cover frame PresenceLight 360 SR	7612748001251	336
9070632	Cover frame PresenceLight 360 BK	7612748001237	336
9070634	Surface frame PresenceLight BK	7612748001176	336
9070635	Surface frame PresenceLight SR	7612748001190	336
9070637	Surface frame compact BK	7612748001329	337
9070638	Surface frame compact SR	7612748001343	337
9070675	SendoPro 868-A	7612748002524	339
9070677	PlanoCover 112x112 EWH	7612748002548	338
9070678	PlanoCover 112x112 EBK	7612748002555	338
9070679	PlanoCover 112x112 ESR	7612748002562	338
9070680	PlanoCover 123x123 UWH	7612748002579	338
9070681	PlanoCover 123x123 UBK	7612748002586	338
9070682	PlanoCover 123x123 USR	7612748002593	338
9070689	Junction casing, 115 x 115 x 100 mm	7612748002661	338
9070712	OT-Box Standard	4003468904763	343
9070731	PlanoBox 1WH	7612748003873	338
9070732	PlanoBox 1BK	7612748003880	338
9070733	PlanoBox 1SR	7612748003897	338
9070735	PlanoBox 1EL	7612748003910	338
9070736	PlanoSet RQ EWH	7612748004696	338
9070737	PlanoSet RQ EBK	7612748004702	338
9070738	PlanoSet RQ ESR	7612748004719	338
9070740	PlanoSet RR EWH	7612748004658	338
9070741	PlanoSet RR EBK	7612748004665	338
9070742	PlanoSet RR ESR	7612748004672	338
9070880	Line coupler S KNX	4003468900253	299
9070892	Power unit top2 GPS	4003468904718	336
9070902	Corner angle theLuxa S WH	4003468900277	340
9070903	Corner angle theLuxa S BK	4003468900284	340
9070904	Corner angle theLuxa P WH	4003468900291	340
9070905	Corner angle theLuxa P BK	4003468900314	340
9070906	Spacer theLuxa S WH	4003468900338	339
9070907	Spacer theLuxa S BK	4003468900345	339
9070908	Spacer theLuxa P WH	4003468900413	339
9070909	Spacer theLuxa P BK	4003468900420	339
9070910	theSenda P	4003468900475	341
9070911	theSenda S	4003468900505	341
9070912	Surface frame 110A WH	7612748004900	337
9070913	Surface frame 110A GR	7612748004917	337
9070917	Ceiling installation box 73A	7612748004979	337
9070918	Surface frame 110B WH	7612748005464	337
9070919	Surface frame 110B GR	7612748005471	337
9070921	Masking clip	7612748005495	337
9070926	Light sensor theRolla	4003468901021	334
9070928	Mast mounting S	4003468901687	345
9070929	DALI-Gateway KNX plus	4003468902394	295
9070949	Surface frame 75A WH	7612748005921	337
9070950	Surface frame 75A BK	7612748005938	337
9070951	Surface frame 75A SR	7612748005945	337
9070956	PS 160 mA T KNX	4003468902271	297
9070957	PS 320 mA T KNX	4003468902288	297
9070958	PS 640 mA T KNX	4003468902295	297

Art.-No.	Type	GTIN/EAN	Page
9070969	Corner angle 10 WH	4003468901700	340
9070970	Corner angle 10 AL	4003468901717	340
9070971	Spacer 10 WH	4003468901724	340
9070972	Spacer 10 AL	4003468901830	340
9070974	Corner angle theLuxa E WH	4003468901939	339
9070975	Corner angle theLuxa E BK	4003468900994	339
9070976	PlanoCover 76 WH	7612748006133	338
9070977	PlanoCover 76 BK	7612748006140	338
9070978	PlanoCover 76 SR	7612748006157	338
9070980	IP Router KNX	4003468901946	298
9070981	IP Interface KNX	4003468901991	298
9070986	Surface frame LUXA 103-100 U	4003468902080	341
9070987	Corner angle 10 BK	4003468902110	340
9070988	Spacer 10 BK	4003468902707	340
9075141	Multiple contact strip	4003468904688	334
9079330	Power unit 24 V DC	4003468903520	345

# Theben AG

## Packaging units

For the optimization of your logistical processes, we offer you the following packaging units in addition to individual packages:

Art.-No.	Type	Number Unit 1	Number Unit 2	Art.-No.	Type	Number Unit 1	Number Unit 2
0010002	ELPA 1	10	-	1020932	theLeda S10 W BK	24	-
0030002	ELPA 3	10	-	1020933	theLeda S20 W WH	16	-
0060002	ELPA 6	10	-	1020933	theLeda S20 W BK	16	-
0080002	ELPA 8	10	300	1020975	LUXA 102-180 LED 32W WH	8	-
0090001	ELPA 9	10	-	1020976	LUXA 102-180 LED 32W BK	8	-
0200000	theben-eltimo 020 S	5	-	1030030	LUXA 103-200	60	-
0200300	theben-eltimo 020 S DCF	5	-	1030031	LUXA 103-200 T	60	-
0260030	theben-timer 26	10	-	1030550	theMova S360-100 AP WH	60	-
0260855	theben-timer 26 IP 44	5	-	1030551	theMova S360-100 AP GR	60	-
0270930	theben-timer 27	10	-	1030555	theMova S360-101 AP WH	60	-
0770802	FRI 77 h-2	5	-	1030556	theMova S360-101 AP GR	60	-
0770832	FRI 77 g-2	5	-	1030560	theMova S360-100 DE WH	72	-
1010200	theLuxa R180 WH	48	-	1030561	theMova S360-100 DE GR	72	-
1010201	theLuxa R180 BK	48	-	1030565	theMova S360-101 DE WH	72	-
1010500	theLuxa S150 WH	24	-	1030566	theMova S360-101 DE GR	72	-
1010501	theLuxa S150 BK	24	-	1040360	SPHINX 104-360 AP	27	-
1010505	theLuxa S180 WH	24	-	1040362	SPHINX 104-360/2 AP	27	-
1010506	theLuxa S180 BK	24	-	1040370	SPHINX 104-360	27	-
1010510	theLuxa S360 WH	24	-	1040372	SPHINX 104-360/2	27	-
1010511	theLuxa S360 BK	24	-	1090100	LUNA 109 AL	5	-
1010605	theLuxa P220 WH	18	-	1090200	LUNA 109 EL	5	-
1010606	theLuxa P220 BK	18	-	1260701	LUNA 126 star	5	-
1010610	theLuxa P300 WH	18	-	1270700	LUNA 127 star	5	-
1010611	theLuxa P300 BK	18	-	1280700	LUNA 128 star	5	-
1019610	theLuxa P300 KNX WH	18	-	1420721	BZ 142-1	10	-
1019611	theLuxa P300 KNX BK	18	-	1510011	SYN 151 h	5	-
1020711	theLeda E10L WH	8	144	1600001	SYN 160 a	10	-
1020712	theLeda E10L BK	8	144	1610011	SYN 161 d	5	180
1020713	theLeda E20L WH	8	144	1690801	SYN 169 s	5	-
1020714	theLeda E20L BK	8	144	1700130	SELEKTA 170 top3	100	-
1020715	theLeda E30L WH	6	144	1710100	SELEKTA 171 top2 RC	60	-
1020716	theLeda E30L BK	6	144	1720100	SELEKTA 172 top2	60	-
1020741	theLeda P12L WH	8	-	1740130	SELEKTA 174 top3	100	-
1020742	theLeda P12L AL	8	-	1790008	TM 179 h	5	-
1020743	theLeda P24L WH	8	-	1800001	SUL 180 a	10	-
1020744	theLeda P24L AL	8	-	1810011	SUL 181 d	5	180
1020721	theLeda S10L WH	24	-	1817008	SUL 181 h 12V	5	-
1020722	theLeda S10L BK	24	-	1880108	SUL 188 hw	5	-
1020723	theLeda S20L WH	16	-	1890108	SUL 189 hw	5	-
1020724	theLeda S20L BK	16	-	1890801	SUL 189 s	5	-
1020775	LUXA 102 FL LED 32W WH	8	-	1891801	SUL 189 s 110V	5	-
1020776	LUXA 102 FL LED 32W BK	8	-	1900001	MEM 190 a	10	-
1020911	theLeda E10 WH	8	144	1910011	SUL 191 w	5	-
1020912	theLeda E10 BK	8	144	2000000	PresenceLight 360	45	-
1020913	theLeda E20 WH	8	144	2000050	PresenceLight 180	45	-
1020914	theLeda E20 BK	8	144	2009000	PresenceLight 360B-KNX WH	45	-
1020915	theLeda E30 WH	6	144	2009050	PresenceLight 180B-KNX WH	45	-
1020916	theLeda E30 BK	6	144	2009100	PresenceLight 360 PLLON WH	45	-
1020941	theLeda P12 WH	8	-	2009150	PresenceLight 180 PLLON WH	45	-
1020942	theLeda P12 AL	8	-	2010001	compact office DIM	45	-
1020943	theLeda P24 WH	8	-	2010080	compact passimo WH	45	-
1020944	theLeda P24 AL	8	-	2010090	compact passage	45	-
1020921	theLeda S10 WH	24	-	2014000	compact office 24V	45	-
1020922	theLeda S10 BK	24	-	2014001	compact office 24V Lux	45	-
1020923	theLeda S20 WH	16	-	2014090	compact passage 24V	45	-
1020924	theLeda S20 BK	16	-	2019280	compact passimo KNX WH	45	-
1020931	theLeda S10 W WH	24	-	2019290	compact passage KNX	45	-

Art.-No.	Type	Number Unit 1	Number Unit 2
2020401	ECO-IR DUAL-C NT	45	-
2030102	PlanoCentro 101-EWH	48	-
2030110	PlanoSpot 360 DALI DE WH	72	-
2030302	PlanoCentro 300-EWH	48	-
2030502	PlanoCentro 201-EWH	48	-
2039100	PlanoSpot 360 KNX DE WH	72	-
2039200	PlanoSpot 360 PSLON DE WH	72	-
2039300	PlanoSpot 360 KNX S DE WH	72	-
2040102	PlanoCentro 000-EWH	48	-
2059102	PlanoCentro EWH-A KNX	48	-
2069102	PlanoCentro EWH PCLON	48	-
2070105	thePrema P360-101 E UP WH	60	-
2070106	thePrema P360-101 E UP GR	60	-
2070130	thePrema P360 Slave E UP WH	60	-
2070131	thePrema P360 Slave E UP GR	60	-
2070600	thePrema S360-100 E UP WH	60	-
2070601	thePrema S360-100 E UP GR	60	-
2070605	thePrema S360-101 E UP WH	60	-
2070606	thePrema S360-101 E UP GR	60	-
2070630	thePrema S360 Slave E UP WH	60	-
2070631	thePrema S360 Slave E UP GR	60	-
2079000	thePrema P360 KNX UP WH	60	-
2079001	thePrema P360 KNX UP GR	60	-
2079500	thePrema S360 KNX UP WH	60	-
2079501	thePrema S360 KNX UP GR	60	-
2080020	theRonda P360-100 M UP WH	60	-
2080021	theRonda P360-100 M UP GR	60	-
2080025	theRonda P360-101 M UP WH	60	-
2080026	theRonda P360-101 M UP GR	60	-
2080030	theRonda P360 Slave UP WH	60	-
2080031	theRonda P360 Slave UP GR	60	-
2080040	theRonda P360-110 DALI UP WH	60	-
2080045	theRonda P360-330 DALI UP WH	60	-
2080550	theRonda S360-100 AP WH	60	-
2080555	theRonda S360-101 AP WH	60	-
2080560	theRonda S360-100 DE WH	72	-
2080565	theRonda S360-101 DE WH	72	-
2080580	theRonda S360-110 DALI UP WH	60	-
2089000	theRonda P360 KNX UP WH	60	-
2690008	SYN 269 h	5	-
4930279	DMB 1 T KNX	40	-
5320001	DIMAX 532 plus	40	-
5340001	DIMAX 534 plus	40	-
5420001	DIMAX 542 plus	40	-
5440001	DIMAX 544 plus	40	-
6100130	TR 610 top3	100	-
6110100	TR 611 top2	100	-
6120130	TR 612 top3	100	-
6220100	TR 622 top2	100	-
7010001	RAMSES 701	10	-
7020001	RAMSES 702	10	-
7030001	RAMSES 703	10	-
7040001	RAMSES 704	10	-
7050001	RAMSES 705	10	-
7060001	RAMSES 706	10	-
7070001	RAMSES 707	10	-
7080001	RAMSES 708	10	-

Art.-No.	Type	Number Unit 1	Number Unit 2
7090001	RAMSES 709	10	-
7150002	SOTHIS 715	5	-
7410130	RAMSES 741	5	-
7460130	RAMSES 746	5	-
7480130	RAMSES 748	5	-

#### Imprint

Client: Theben AG, Haigerloch  
Product data manager: Arne Mohl  
Realisation: Theben AG, Haigerloch  
Layout: Theben AG  
Picture sources: Theben AG, Detlef Majer  
Print: ProWachter GmbH

# Theben AG

## List of discontinued models

Type	Art.-No.	Type	Art.-No.
<b>Discontinued product</b>		<b>Successor</b>	
LUXA 102 FL LED 8W W WH	1020751	theLeda S10L WH (Colour temperature 4000 K)	1020721
LUXA 102 FL LED 8W W BK	1020752	theLeda S10L BK (Colour temperature 4000 K)	1020722
LUXA 102 FL LED 16W W WH	1020753	theLeda S20L WH (Colour temperature 4000 K)	1020723
LUXA 102 FL LED 16W W BK	1020754	theLeda S20L BK (Colour temperature 4000 K)	1020724
LUXA 102 FL LED 8W WH	1020771	theLeda S10L WH (Colour temperature 4000 K)	1020721
LUXA 102 FL LED 8W BK	1020772	theLeda S10L BK (Colour temperature 4000 K)	1020722
LUXA 102 FL LED 16W WH	1020773	theLeda S20L WH (Colour temperature 4000 K)	1020723
LUXA 102 FL LED 16W BK	1020774	theLeda S20L BK (Colour temperature 4000 K)	1020724
LUXA 102-140 LED 8W W WH	1020951	theLeda S10 W WH	1020931
LUXA 102-140 LED 8W W BK	1020952	theLeda S10 W BK	1020932
LUXA 102-140 LED 16W W WH	1020953	theLeda S20 W WH	1020933
LUXA 102-140 LED 16W W BK	1020954	theLeda S20 W BK	1020934
LUXA 102-140 LED 8W WH	1020971	theLeda S10 WH (Colour temperature 4000 K)	1020921
LUXA 102-140 LED 8W BK	1020972	theLeda S10 BK (Colour temperature 4000 K)	1020922
LUXA 102-140 LED 16W WH	1020973	theLeda S20 WH (Colour temperature 4000 K)	1020923
LUXA 102-140 LED 16W BK	1020974	theLeda S20 BK (Colour temperature 4000 K)	1020924
SPHINX 331 S KNX	1079215	theRonda S360 KNX FLAT DE WH	2089560
SPHINX 332 S KNX	1079216	theRonda S360 KNX FLAT DE WH	2089560
SELEKTA 170 top2	1700100	SELEKTA 170 top3	1700130
theMova S360 KNX AP WH	1039550	theRonda S360 KNX AP WH	2089550
theMova S360 KNX AP GR	1039551	theRonda S360 KNX AP GR	2089551
theMova S360 KNX DE WH	1039560	theRonda S360 KNX FLAT DE WH	2089560
theMova S360 KNX DE GR	1039561	theRonda S360 KNX FLAT DE GR	2089561
theMova P360 KNX UP WH	1039600	theRonda P360 KNX UP WH	2089000
theMova P360 KNX UP GR	1039601	theRonda P360 KNX UP GR	2089001
SUL 181 h 24V	1814008	SUL 181 d 24V	1814011
SUL 181 h 12V	1817008	SUL 181 d 24V	1814011
compact office 24V BK	2014800	No direct successor (compact office 24V as device in white possible)	-
compact office 24V SR	2014801	No direct successor (compact office 24V as device in white possible)	-
compact office 24V Lux BK	2014803	No direct successor (compact office 24V Lux as device in white possible)	-
compact office 24V Lux SR	2014804	No direct successor (compact office 24V Lux as device in white possible)	-
compact passage 24V BK	2014806	No direct successor (compact passage 24V as device in white possible)	-
compact passage 24V SR	2014807	No direct successor (compact passage 24V as device in white possible)	-
compact passimo 24V WH	2014810	No successor	-
compact passimo 24V BK	2014811	No successor	-
compact passimo 24V SR	2014812	No successor	-
DMB 2 S KNX	4910272	DMB 1 T KNX	4930279
HMT 6 KNX	4900273	HMT 6 S KNX	4900373
HMT 12 KNX	4900274	HMT 12 S KNX	4900374
TA 2 KNX	4969202	TA 2 S KNX	4969222
TA 4 KNX	4969204	TA 4 S KNX	4969224
TA 6 KNX	4969206	TA 6 S KNX	4969226
TR 610 top2	6100100	TR 610 top3	6100130
TR 612 top2	6120100	TR 612 top3	6120130
RAMSES 712 KNX	7129200	RAMSES 718 S KNX	7189200
RAMSES 713 S KNX	7139201	RAMSES 718 P KNX	7189210
AMUN 716 R	7160101	AMUN 716 SR	7160110
AMUN 716 S KNX	7169200	AMUN 716 S KNX	7169230
RAMSES 813 top2 HF Set S	8139505	No successor	-
clic	9070515	No successor	-
LUXA LED corner angle WH	9070756	No successor	-
LUXA LED corner angle BK	9070757	No successor	-
Power supply 160 mA S KNX	9070922	PS 160 mA T KNX	9070956
Power supply 320 mA S KNX	9070923	PS 320 mA T KNX	9070957
Power supply 640 mA S KNX	9070924	PS 640 mA T KNX	9070958
HMT 6 KNX	4900273	HMT 6 S KNX	4900373
HMT 12 KNX	4900274	HMT 12 S KNX	4900374

## Practical, informative, comprehensive Solution and application brochures

In our brochures, you will find many practical solutions and important background knowledge all around the efficient and convenient building control, apart from the numerous product advantages. We would also be pleased to send you our brochure free of charge by mail to your home. The order form can be found at [www.theben.de/katalog](http://www.theben.de/katalog)



### Cleverly automated KNX home and building automation

PDF-Download: [www.theben.de/en/knx-bro-en](http://www.theben.de/en/knx-bro-en)



### Illuminating and versatile Presence and motion detectors

PDF-Download: [www.theben.de/en/pir-bro-en](http://www.theben.de/en/pir-bro-en)



### Reliable switching and dimming LED-compatible solutions

PDF-Download: [www.theben.de/en/led-bro-en](http://www.theben.de/en/led-bro-en)



### Convenient, quick, safe KNX visualisation theSera

PDF-Download: [www.theben.de/en/thesera-bro-en](http://www.theben.de/en/thesera-bro-en)

# Theben AG

## General Delivery and Sales Conditions

For use with companies (status 2016-09-01)

### Preamble

All deliveries and services are based - also in the future - exclusively on the following conditions, even if we do not refer to them specifically in the individual case. Their validity can only be partly or totally excluded by express written agreement for an individual transaction. General terms and conditions, especially purchase conditions of the purchaser, shall not apply to our deliveries and services. We shall not be bound by these terms and conditions even if we do not object to them expressly in an individual case; we herewith object to them. Our General Delivery and Sales Conditions are regarded as accepted, at the latest with the acceptance of the goods or the service.

### I. SCOPE OF DELIVERY OBLIGATIONS

1. Our offers are non-binding, even if made on the purchaser's request. A legally binding contractual relationship with the purchaser shall only be constituted once we have confirmed the order in writing, which may also be possible by fax, by letters created automatically without signature, or e-mail; the same applies to modifications or amendments to the contract. As far as scope, type and time of the delivery are concerned, our written order confirmation shall be binding.

2. We reserve the right to any modifications of construction, production and design of our products. Our catalogues and our product presentations published on the Internet are continually being updated. Any illustrations and drawings contained therein shall not be binding and shall not be part of the properties agreed upon. They neither represent any guarantee for durability nor quality.

3. The documents belonging to the offer, such as drawings, data sheets, figures, diagrams, files, etc., shall only be approximates where not expressly described as being binding. The documents shall remain our property; we reserve all rights to them. Without our written consent, they must not be disclosed to any third party and they must be returned to us at any time on request.

4. Call orders must be placed and accepted in due time and with the partial quantities agreed. In case of call orders where term, production batch quantities and release times have not been agreed, we shall be entitled to request a binding definition of the releases 3 months after the date of the order confirmation, at the latest. If the purchaser does not comply with this request within 3 weeks, we shall be entitled to grant him a last additional period of two weeks for doing so and when this additional period has lapsed as well, we shall be entitled to withdraw from the contract or to refuse delivery and claim damages. In any case, the entire quantity ordered in the call order has to be accepted and to be paid by the purchaser 18 months after the order, except when otherwise stipulated. If the contractual quantity should be exceeded by the individual calls, we shall be entitled to deliver the surplus, but not obligated to do so. We can charge for the excess at the prices valid at the time of the call or the delivery.

### II. PRICE

1. All prices are quoted in EURO. The applicable value added tax shall be charged separately.

2. The prices quoted apply to delivery ex works, without insurance and packaging.

3. Surcharges and a recalculation of the agreed remuneration shall be admissible as far as they are necessitated by the circumstances, e.g. material costs, wage or energy cost increases, an increase of the public charges etc., and if the goods or services are to be provided later than 4 months after the contract date. In case of any other price increases, the purchaser shall be entitled to withdraw from the contract if the list price has been increased far more than the general costs of living. Any deliveries for subsequent orders that are placed after the date of the price adjustment shall be charged at the new prices without the purchaser being entitled to withdraw from the contract.

### III. DELIVERY

1. The delivery term shall start with the dispatch of the order confirmation, but not before all details of the perfor-

mance of the order have been clarified and not before receipt of an agreed advance payment or provision of material; the delivery terms are always stated by us subject to our own supply by our suppliers. The delivery term shall be deemed to have been complied with when the delivery item has been dispatched or collected before the expiration of this term or when a ready-for-dispatch note has been issued in cases where the goods could not be dispatched or collected without our being responsible for this.

2. In case of force majeure or other events beyond our responsibility that would threaten the smooth processing of the order, in particular delivery delays of our suppliers, disturbances of traffic or operation, industrial disputes, shortage of materials or energy, we shall be entitled to withdraw, entirely or partially, from the contract or to postpone delivery without the purchaser being entitled to claim damages. The purchaser may request from us a statement specifying whether we want to withdraw or whether we want to fulfil the contract within an adequate period of time. If we do not make such a statement, the purchaser shall be entitled to withdraw from the contract. We shall not be liable for the events or circumstances referred to above even if they occur during an existing delay of delivery.

3. In case of a delivery delay for which we are responsible, the purchaser shall grant us an adequate grace period. Once this period has expired, the purchaser may claim damages and/or withdraw from the contract insofar as the goods have not been delivered or indicated as being ready for dispatch until the end of this period. The purchaser is not entitled to withdraw from the contract if delivery delay has not been caused by us.

4. The purchaser is only entitled to claim damages as a replacement for the services if the cause of the damage is based on intent or gross negligence on our part. This does not apply if it is a firm deal.

5. The delivery obligations and the delivery terms shall be suspended as long as the purchaser is in delay with acceptance of the goods or any other obligation, without our rights from the purchaser's delay being thereby affected, or without him exceeding the credit limit granted by us. In this case, the risk of accidental loss or accidental deterioration shall pass to the purchaser from the date he is in delay.

6. The delivery term originally agreed shall no longer apply if the order is modified with our written consent.

7. Adequate partial deliveries as well as deviations from the order quantities (max. +/- 5 %) shall be admissible if the purchaser can be reasonably expected to accept this and as long as the latter's interests are taken into account.

8. The weight and the number of pieces of the goods delivered determined by us shall be decisive for the invoicing.

### IV. DISPATCH

1. The goods shall be dispatched at the purchaser's costs and risk from a location to be determined by us.

2. Unless the purchaser has submitted any special requests, we shall choose, at our own discretion, the packaging, as well as type and channel of dispatch. The additional costs for special wishes of the purchaser shall be borne by the latter. We shall not be obliged to choose the cheapest type of dispatch.

3. If the dispatch or the delivery is delayed upon the purchaser's request, we shall be entitled to set him an adequate period of time for accepting the goods and to demand immediate acceptance as well as a compensation for the damage caused by the delay once this period has lapsed.

### V. TERMS OF PAYMENT

1. Payments shall be made in accordance with the conditions specified in our order confirmation.

2. The purchaser bears the costs for his payment, especially all kinds of banking charges and expenses.

3. Cheques shall be accepted only with the usual proviso. With any type of payment, the settlement date shall be the

day on which we can dispose over the amount due.

4. If a deferment of payment is granted or if the purchaser is in default with his obligations to pay, he shall, in the meantime, be liable to pay interests of 9 percent above the respective basic interest rate, without the need for a reminder notice. We reserve the right to claim further damages due to the delay. The purchaser reserves the right to prove that lower damages have been incurred. Furthermore, we are entitled to charge the purchaser a fixed rate of € 40.00 for the reminder.

5. The purchaser shall not be entitled to offset payments against any counter claims or rights unless his claims or rights are acknowledged by us, uncontested or final and absolute. The purchaser is not entitled to retain payments on account of disputed counterclaims either.

6. All our claims are due immediately if terms of payment are not adhered to, or we become aware of circumstances which appear to impair the creditworthiness of the purchaser. In this case, we are also entitled to supply outstanding consignments on cash-in-advance terms or security deposit, or to withdraw from the contract after a reasonable grace period and/or claim damages for non-fulfilment. In addition, we may prohibit the resale or processing of the goods delivered and request that the purchaser, at his costs, return the goods to us or assign the indirect possession of the goods delivered, and withdraw the authorization to collect claims pursuant to Section IX. 7. Already now, the purchaser agrees that we shall, in the mentioned cases, be authorized to enter into his premises and to take away the goods delivered.

7. Payments shall generally be set off against the oldest invoice that is due for payment. As long as an older invoice has not been paid, the purchaser is not entitled to discount on later invoices.

### VI. COMPLAINTS AND NOTICES OF DEFECT

1. Complaints because of incomplete or incorrect delivery or notices of evident defects must be delivered to us in writing immediately, at the latest, however, within 2 weeks after receipt of the goods. Any other defects must be reported to us in writing immediately, at the latest, however, within 2 weeks after they have been detected. If we have not received the complaint or notice of defect in due time, any warranty claims of the purchaser shall be excluded. In case of defects reported in due time, the purchaser shall be entitled to the claims according to Section VII.

2. In case of damage in transit, the purchaser must procure an ascertainment of the damage by the railroad company, the postal service or the transport company.

3. If a part of the goods delivered is defective, the purchaser shall not be entitled to reject the entire delivery, unless the partial delivery is of no interest to the purchaser.

### VII. WARRANTY

1. The purchaser's claims for supplementary performance shall be time-barred within 12 months from the statutory start of the limitation period. The same applies for withdrawal and diminution. This time limit does not apply if:

- the law according to § 438 section 1 no. 2 BGB and § 634a section 1 no. 2 BGB requires longer time periods,
- in case of intent,
- in case of fraudulent concealment, and
- in case of non-compliance with a quality guarantee.

We shall be obliged, at our option, to eliminate any defects or make a replacement delivery if the delivery items are defective. The purchaser's reimbursement claims for expenses according to § 445a BGB shall also be time-barred within 12 months from the statutory start of the limitation period, provided that the last contract in the supply chain is not a consumer goods purchase. Any legal provisions regarding suspension of expiration, suspension and recommencement of the limitation period remain unaffected. Reimbursement claims against us according to § 445a BGB are only valid if the purchaser has not made an agreement with his customer which goes beyond the statutory claims for defects.

2. The purchaser shall grant us the time and opportunity that, in our equitable discretion, is required for the elimination of the defects. Any parts that are replaced shall become our property.

3. If the supplementary performance fails, if we let the adequate period granted to us for this purpose expire without making a new delivery or without eliminating the defect, or if subsequent performance is impossible or refused by us, the purchaser shall be entitled to withdraw from the contract or demand a reduction of the purchase price, the same shall apply to cases where we are unable to provide supplementary performance.

4. The warranty shall neither apply to defects and/or damage due to normal wear and tear nor defects and/or damage caused by inappropriate or negligent use, excessive stress, improper use, wrong handling etc. or circumstances that are not provided for in the contract unless the damage is due to our fault.

5. Without our consent, warranty claims may not be assigned to any third party.

6. We shall not be liable for any defects caused by improper modifications or repairs that are carried out by the purchaser or a third party.

7. Our liability for essential third-party products shall be restricted to the assignment of the warranty claims we are entitled to from the supplier of the third-party product unless satisfaction from the assigned right fails or the assigned claim cannot be enforced for any other reasons.

8. Unless otherwise provided below, any further claims of the purchaser against us, irrespective of the legal cause thereof, shall be excluded, in particular claims for the compensation of a damage that does not exist and/or occur in the goods delivered themselves (e.g. loss of profit, consequential damage or other economic losses); this exemption from liability shall not apply if liability is required by law because of deliberate action, gross negligence or a promise of guarantee or if an essential contractual obligation has been violated or in case of injuries to life and limb or health.

In case of negligent, but not grossly negligent violation, our liability shall be restricted to the replacement of the typical foreseeable damage.

9. The above provisions shall apply accordingly to the delivery of other goods than those agreed upon in the contract.

#### VIII. LIABILITY, PERIOD OF LIMITATION

1. The exclusion and the limitations of our liability for damages as set forth in Section VII. 8 shall apply accordingly to all cases of our liability for damages due to violation of contractual, or quasi-contractual obligations and tortious act. They shall not apply to claims pursuant to Paragraphs 1 and 4 of the Product Liability Law and to claims due to initial inability to perform at the point of conclusion of the contract or impossibility for which we are responsible. This exemption from liability shall not apply if liability is required by law because of deliberate action, gross negligence or a promise of guarantee or if an essential contractual obligation has been violated or in case of injuries to life and limb or health.

2. If our liability for damages is excluded or restricted, this shall apply in the same way to the personal liability of our executive bodies, employees or authorized agents.

3. The claims of the purchaser referred to in Sec. 1 shall become time-barred after 24 months, calculated from the end of the year of the passing of the risk. If the statutory period of limitation is shorter than 24 months, this statutory period shall be applicable to the relevant claims on the part of the purchaser. This reduction of the period of limitation shall not apply to claims for reasons of tortious act or product liability.

4. The statutory provisions concerning the burden of proof shall remain unaffected.

#### IX. RETENTION OF TITLE

1. All goods delivered (goods subject to retention of title) shall remain our property until all and any claims to which we are entitled because of the business relationship, in particular the outstanding balance claims, have been fully settled by the purchaser. This shall also apply when payments are made on specially designated claims.

2. If the goods subject to retention of title are combined with other goods by the purchaser, we shall acquire co-ownership of the new object pro rata of the invoice value of the goods subject to retention of title to the invoice value of the other goods used. If our ownership lapses due to a combination, the purchaser herewith agrees to assign to us his property rights to the new objects to the amount of the invoice value of the goods subject to retention of title and keeps them for us, free of charge. The resulting co-ownership rights shall be considered as goods subject to retention of title within the meaning of Section 1. We accept the assignment.

3. The purchaser may sell the goods subject to retention of title in the normal course of business at his terms and conditions only if these contain a comprehensive retention of title in accordance with the provisions set forth herein, and as long as he is not in default, provided that the claims from the resale pass to us pursuant to Sections 4. and 6. hereof. The purchaser does not have any other right of disposition of the goods subject to retention of title, in particular the authorisation to dispose of the goods subject to retention of title shall be automatically revoked if insolvency proceedings are applied for or liquidation commenced regarding the assets of the purchaser

4. The claims of the purchaser from reselling the goods subject to retention of title are herewith assigned to us. They serve as security to the same extent as the goods subject to retention of title. We herewith accept the assignment.

5. If the purchaser sells the goods subject to retention of title together with other goods not obtained from us, the assignment of claims from the resale shall only correspond to the amount of the invoice value of the goods subject to retention of title that are sold in the individual case. When goods in which we have a co-ownership share pursuant to Sec. 2. are sold, the claims shall be deemed to have been assigned corresponding to the value of this co-ownership shares.

6. If the purchaser uses the goods subject to retention of title for the execution of a contract for work, Sections 4. and 5. shall apply accordingly to the claims from this contract.

7. The purchaser shall be entitled to collect claims from sales according to Sections 3., 5., and 6. until this permission is revoked by us, which shall be admissible at any time. We will only make use of the right of revocation in the cases specified in Section 3., as well as V. 5. Any other assignment of the claims by the purchaser shall not be permitted. Upon our request, the purchaser shall be obliged to inform his customers immediately about this assignment to us – unless we do it ourselves – and to provide any information and documents required for the collection of claims to us. The purchaser is prohibited from hypothecation or transfer of the goods by way of security.

8. Our retention of title implies that, once all our claims have been fully paid, the title to the goods subject to retention of title shall ipso jure pass to the purchaser and he shall be entitled to the assigned claims without any restrictions. If the value of the existing securities exceeds the secured claims by more than 20 % in total, we shall be obliged to release securities accordingly, at our option, on request of the purchaser. The assessment of securities shall be based on their realizable value.

9. The purchaser shall inform us immediately about any seizure or any other threat or impairment to our ownership rights or claims by a third party and provide the bailiff's return or any other documents to us and he shall do anything within his power to protect our rights.

10. We shall be entitled at any time to enter into the warehouse and the business premises of the purchaser, in order to remove, separate or label the goods subject to retention of title. At our request, the purchaser shall provide any relevant information concerning the goods subject to retention of title and hand over the related documents. The purchaser, at his costs, shall be obliged to provide comprehensive insurance coverage for the goods subject to retention of title in our favour and to supply evidence thereof on request. He herewith assigns all claims from these insurances to us; we accept the assignment.

11. The assertion of our retention of title or the revocation of the authorizations granted herein shall not be considered as a withdrawal from the contract. The purchaser's right of possession in the goods subject to retention of title expires if he does not meet his obligations arising from this or another contract. We shall then be entitled to take possession of the goods subject to retention of title ourselves and to exploit them in the best possible way by means of a private sale or an auction, without prejudice to the payment obligations or any other duties of the purchaser. The proceeds thus realized shall be appropriated to the purchaser's outstanding payments after the costs have been deducted. Should there be any surplus, this shall be paid to the purchaser.

12. If the retention of title or the assignment is not effective under the law to which the goods belong, the corresponding security valid in this field of law shall be deemed as agreed. If the cooperation of the purchaser is required in this context, he shall take any measures that are necessary for the constitution and preservation of such rights.

#### X. TOOLS

1. Tools, moulds, appliances and the like - in the following referred to as "tools" - are in principle our assets, even if the purchaser had paid for these wholly or partially. This shall apply irrespective of whether the tools were manufactured by us or by commissioned third parties.

2. We undertake not to manufacture any parts for third parties using tools for which the purchaser has paid the entire cost, providing the purchaser supplies us with follow-up orders. This obligation expires without a claim for reimbursement of any type against us arising for the purchaser if we do not receive further orders within two years after the last order.

3. We shall store the tools in good condition free of charge. The purchaser shall bear the costs of maintenance and repairs. Our obligation to store the tools shall come to an end after expiry of the two-year period stated in Sec. 2. We shall be entitled to dispose of the tools afterwards.

4. The provisions above (Sections 1 to 3) shall not apply to tools for common and generally usable items.

#### XI. PROTECTIVE RIGHTS OF THIRD PARTIES

Insofar as we have to manufacture products on the basis of drawings, specifications, models, or samples given to us by the purchaser, the purchaser takes upon himself the responsibility of guaranteeing to us that the rights of third parties are not infringed upon. In case of violation, the purchaser will indemnify us in full from any claims by third parties and fully reimburse us for any resulting damages. If a third party claims its industrial property rights we are entitled to stop the manufacturing or delivering of the items immediately without checking the legal situation.

#### XII. MISCELLANEOUS PROVISIONS

1. The place of performance and jurisdiction for both parties under the contract is D-72401 Haigerloch, Germany. We are also entitled to file an action against the purchaser at the purchaser's general place of jurisdiction.

2. All legal relations between the purchaser and us shall be governed exclusively by law of the Federal Republic of Germany.

3. Should one or several of the provisions of these terms and conditions or the other contractual provisions be or become invalid, this shall not affect the validity of the remaining provisions. The invalid provisions shall be interpreted in such a way that the legal and economic purpose intended with them is achieved to the greatest possible extent. The same shall apply if, during the execution of the agreement, a gap in the agreement requiring an amendment becomes evident. The contracting parties undertake to replace the ineffective provisions immediately by legally valid provisions or to close the contractual gap.

4. We shall store the purchaser's data for the purposes of the contractual relationship.

# Theben Worldwide

## Headquarter | Theben Group Companies

### Headquarter

#### Theben AG

Hohenbergstr. 32  
D-72401 Haigerloch, GERMANY  
Phone +49 7474 692-0  
Fax +49 7474 692-150  
info@theben.de  
www.theben.de

### Theben Group Companies

#### AUSTRALIA

##### Theben PTY LTD

Unit 1/14 Drury Terrace  
5042 Clovelly Park, South Australia  
Phone +61 8 8463 1163  
Fax +61 8 8464 0277  
sales@thebenpty.com.au  
www.theben.de/en

#### FINLAND

##### Theben OY

Liikkalankuja 6  
00950 Helsinki  
Phone +358 9 4242 7877  
info@theben.fi  
www.theben.fi

#### FRANCE

##### Theben S.A.R.L.

ZAC de la Madeleine  
15 Rue de la Tuilerie  
77500 Chelles  
Phone +33 1 82770100  
Fax +33 1 60200083  
theben@theben.fr  
www.theben.fr

#### GREAT BRITAIN

##### Timeguard Ltd

Victory Park, 400 Edgware Road  
London NW2 6ND  
Phone +44 208 4508944  
Fax +44 208 4525143  
csc@timeguard.com  
www.timeguard.com

#### ITALY

##### Theben S.R.L.

Piazza Giorgio La Pira 4  
20851 Lissone (MB)  
Phone +39 039 9370 589  
Fax +39 039 9370 608  
info@theben.it  
www.theben.it

#### NETHERLANDS

##### Theben Nederland

Laan van de Leeuw 34  
7324 BD Apeldoorn  
Phone +31 55 2020000  
Fax +31 55 2020001  
nederland@theben.de  
www.theben.de/nl

#### NORWAY

##### Theben AG

Janaflaten 47  
5179 Godvik  
Phone +47 55100667  
info@theben.no  
www.theben.no

#### SINGAPORE

##### Theben Asia Pte Ltd

25 International Business Park,  
German Center #03-22/23  
609916 Singapore  
Phone +65 6560 3464-5  
Fax +65 6560 5929  
info@theben-asia.com  
www.theben.asia

#### SWEDEN

##### Theben Electronics AB

Kanalvägen 16  
19461 Upplands Väsby  
Phone +46 10 450 7200  
info@theben.se  
www.theben.se

#### SWITZERLAND

##### Theben HTS AG

Im Langhag 7b  
8307 Effretikon, SWITZERLAND  
Phone +41 52 355 1700  
Fax +41 52 355 1701  
info@theben-hts.ch  
www.theben-hts.ch

## KNX-Partners

### AUSTRALIA

#### Ivory Egg Aust Pty. Ltd.

Unit 23/6, Jubilee Ave  
2102 Warriewood  
Phone +61 13 0081 1510  
sales@ivoryegg.com.au  
www.ivoryegg.com.au

### EGYPT

#### Greentec Automation DMCC

Office no. 1002, SABA Tower 1  
Cluster E Jumeirah Lakes Tower  
P.O. Box 346075  
DUBAI  
Phone +971 4551 6092  
Fax +971 4551 6073  
info@greentec-automation.com  
www.greentec-automation.com

### INDIA

#### Light & Magic Automation Pvt.

Shop No. 9-10-11, Ruby Apartment,  
MV Road, Andheri East  
Mumbai 400 069  
Phone +91 22 2684 5454  
Fax +91 22 3260 1603  
mihir.shah@advancedindia.com  
www.advancedindia.com

### INDIA

#### Venba Tech Pvt. Ltd.,

First Floor, Dilmas Sware  
No. 27 , 1st floor  
Shafee Mohammed Road  
Nungambakkam  
Chennai 600006 India  
Phone +91 44 2829 0898

### LEBANON

#### Greentec Automation DMCC

Office no. 1002, SABA Tower 1  
Cluster E Jumeirah Lakes Tower  
P.O. Box 346075  
DUBAI  
Phone +971 4551 6092  
Fax +971 4551 6073  
info@greentec-automation.com  
www.greentec-automation.com

### MALAYSIA

#### A & S Building Tech Sdn Bhd

45-4, Jalan PJU 1/37  
Block G , Dataran Prima, Petaling Jaya  
47301, Selangor Darul Ehsan  
Malaysia  
Phone + 603 7780 2710  
Fax +603 7880 2712

### MALAYSIA

#### Seikou Systec Sdn Bhd

Jln 9/125D, Desa Petaling No 16-2  
57100 Taman Desa Petaling  
Kuala Lumpur  
Malaysia  
Phone: + 603 9057 7793  
Fax + 603 9057 7795

### NEW ZEALAND

#### Ivory Egg (NZ) Ltd.

14 Mount Pleasant Avenue  
7010 Beachville, Nelson  
Phone +64 22 3207665  
colin@ivoryegg.co.nz  
www.ivoryegg.co.nz

### NORWAY

#### Instell AS

Gjerdrumsvei 16, 0484 Oslo  
Phone +47 22 021 450  
Fax +47 22 021 451  
instell@instell.no  
www.instell.no

### THAILAND

#### Ibuilt Automation Co., Ltd.

44, 44/1 Rungsiya Village  
Ramintra 64, Kannayao Bangkhen  
Bangkok 10230  
Phone +66 2 918 05613  
Fax +66 2 918 0564  
patomporn@ibuilt.co.th  
www.ibuilt.co.th

### UNITED ARAB EMIRATES

#### Greentec Automation DMCC

Office no. 1002, SABA Tower 1  
Cluster E Jumeirah Lakes Tower  
P.O. Box 346075  
DUBAI  
Phone +971 4551 6092  
Fax +971 4551 6073  
info@greentec-automation.com  
www.greentec-automation.com

# Theben Worldwide Worldwide Agencies

## AFGHANISTAN

**Greentec Automation DMCC**  
Office no. 1002, SABA Tower 1  
Cluster E Jumeirah Lakes Tower  
P.O. Box 346075  
DUBAI  
Phone +971 4551 6092  
Fax +971 4551 6073  
info@greentec-automation.com  
www.greentec-automation.com

## ARGENTINA

**Hertig S.A.**  
Bolivar 1335  
C1141AAD Ciudad de Buenos Aires  
Phone +54 11 43617136  
ventas@hertig.com.ar  
www.hertig.com.ar

## AUSTRIA

**Siblik Elektrik Ges.M.B.H. & Co.KG**  
Murbangasse 6  
1108 Wien  
Phone +43 1 680060  
info@siblik.com  
www.siblik.com

## BAHRAIN

**Greentec Automation DMCC**  
Office no. 1002, SABA Tower 1  
Cluster E Jumeirah Lakes Tower  
P.O. Box 346075  
DUBAI  
Phone +971 4551 6092  
Fax +971 4551 6073  
info@greentec-automation.com  
www.greentec-automation.com

## BELGIUM

**Tempolec S.A.**  
Route de Biesme 49  
6530 Thuin  
Phone +32 71 590039  
info@tempolec.be  
www.tempolec.be

## CANADA

**Davis Controls Ltd.**  
2200 Bristol Circle  
Oakville Ontario L6H 5R3  
Phone +1 905 8292000  
info@daviscontrols.com  
www.daviscontrols.com

## COLOMBIA

**THL LTDA**  
Cra, 49 B # 91-33, Bogota D.C  
Phone +57 1 6218550  
ventas-thl@thl.com.co  
www.thl.com.co

## CROATIA

**IGM Solutions j.d.o.o.**  
Jurja Dobrile 18, 51000 Rijeka  
Phone +385 51624776  
IGM.jdoo@gmail.com

## CYPRUS

**Pambos Nicolaou & Son Ltd.**  
Kimonos 6 Str., Tseri, 2480 Nicosia  
Phone +35 22 38 03 77  
nicha@cytanet.com.cy  
www.pambosnicolaou.com

## CZECH REPUBLIC

**Elektro-System-Technik**  
Spol. S. R. O., Pod Pekarnami 338/12  
19000 Praha 9  
Phone +42 266 090711  
est@est-praha.cz  
www.est-praha.cz

## EGYPT

**Cairo Electrical Group**  
Garden City  
9, Rostroum Str. Apt. 37  
11516 Maglis El Shaab Cairo  
Phone +202 2796 1337  
celeg@link.com.eg

## ESTONIA

**Vallin Baltic As**  
Mäepealse 2, 12618 Tallinn  
Phone +372 6593200  
info@vallin.ee  
www.vallin.ee

## GREECE

**V. KAFKAS S.A.**  
Electrical Materials & Lighting  
1st km Markopoulou Ave.  
190 02 Peania  
Phone +30 216 3003000  
info@kafkas.gr  
www.kafkas.gr

## HONG KONG

**Friends Environmental Material**  
Room906A, Kin Tak Fung  
Industrial Centre, Wai Yip Street 174  
Kwun Tong Kln, Hong Kong  
Phone +852 29519710  
allenli62@hotmail.com

## HUNGARY

**Elektro Kamleithner Kft**  
Jokai utca 32, fszt 4  
1195 Budapest  
Phone +361 4253288  
info@theben.hu  
www.theben.hu

## ICELAND

**Reykjafell Ltd.**  
Skiptiholti 35, 105 Reykjavik  
Phone +354 588 60 00  
reykjafell@reykjafell.is  
www.reykjafell.is

## INDIA

**Cape Electric Private Limited**  
A-41 (B), SIPCOT Industrial  
Growth Centre,  
Oragadam, Sriperumbudur Taluk,  
Kancheepuram Dist., Tamil Nadu -  
602 105  
Phone +91 44 37477000  
chennai@capeindia.net  
www.capeindia.net

## INDONESIA

**PT Guna Era Distribusi**  
Jl. Rawa Gelam li No. 8  
Kawasan Industri Pulogadung  
Jakarta Timur 13930  
Phone +62 21 46825050  
C-Service@ged-gae.co.id  
www.gae.co.id

## IRAN

**S. G. Riazi Trading**  
#4. No. 29 Parasto. Str  
St. Valiasr Ave., 15929 Tehran  
Phone +98 21 888 903 40  
info@sgrtrading.net  
www.sgrtrading.net

## IRELAND

**Inter-Konnect**  
Unit 1, 97-98 Lagan Road  
Dublin Industrial Estate  
D11RX96 Glasnevin Dublin 11  
Phone +353 1 830 4666  
info@inter.ie  
www.interkonnect.ie

## ISRAEL

**Galoz Electronics Ltd.**  
Galoz Building; 7, Hameretz Street  
Rosh Ha'Ayin 4801707  
Phone +972 3 9023456  
sales@galoz.co.il  
www.galoz.co.il

## JORDAN

**Noor Ala Noor Est.**  
245 Gardens Street - Khilda  
11192 Amman  
Phone +962 65332410  
hothyfa@nooralanoor.net  
www.nooralanor.net

## KOREA

**Mahani Electric., LTD.**  
Bisan 2dong, 576-8  
Anyang City, Kyunggki-do, Korea  
Phone +82 2 2194 3339  
yskim@hanmec.co.kr  
www.mec.co.kr

## LATVIA

**SIA Vallin**  
322 Maskavas iela, 1063 Riga  
Phone +371 6718 7204  
info@vallin.lv  
www.vallin.lv

## LEBANON

**Garabed Ayanian + Sons**  
176 Gouraud Street, Beirut  
Phone +961 1 255222  
gasons@dm.net.lb

## LIBYA

**Bowabt Al-Magd (W.L.L)**  
Aljraba Street, Tripoli  
Phone +218 213 603240  
eng.gelaw@gmail.com

## LITHUANIA

**Vallin SIA**  
Pelesos gatve. 3, 306.k., Vilnius  
Phone +370 527 288 93  
info@vallin.lt  
www.vallin.lt

## LUXEMBOURG

**Marco Zenner S. A. R. L.**  
Zone Industrielle Zare Est  
4385 Ehlerange  
Phone +352 44 15 44 1  
contact@zenner.lu  
www.zenner.lu

# Theben Worldwide Worldwide Agencies

## MALAYSIA

### Electech Distribution Systems

16-1, Jalan 6/89 B, Batu 3 1/2,  
Kawasan Perindustrian Triges  
Off Jalan Sungei Besi  
57100 Kuala Lumpur  
Phone +60 3 7981 8950  
info@edsm.com.my  
www.edsm.com.my

## MONTENEGRO

### Rarovac Komerc Podg.

Bracana Bracanovica 6, 81000 Podgorica  
Phone +38 1 81609091  
rarovackomerc@t-com.me

## MOROCCO

### General Technics

77 Rue Rahal Ben Ahmed  
Belvédère, 20300 Casablanca  
Phone +212 5 22 246170  
genotech@menara.ma

## NEW ZEALAND

### Hamer Ltd.

85a Falsgrave Street  
8011 Christchurch  
Phone +64 800 239 239  
www.hamer.co.nz

## OMAN

### Stars Light L.L.C.

P.O. Box 2822, 112 Ruwi  
Phone +968 697 025  
starmail@omantel.net.om  
www.starslightllc.com

## PAKISTAN

### Greentec Automation DMCC

Office no. 1002, SABA Tower 1  
Cluster E Jumeirah Lakes Tower  
P.O. Box 346075  
DUBAI  
Phone +971 4551 6092  
Fax +971 4551 6073  
info@greentec-automation.com  
www.greentec-automation.com

## POLAND

### PPUH El-Team Sp. Z.O.O.

Al. Mlodych 26-28  
41-106 Siemianowice  
Phone +48 322 043 628  
el-team@el-team.com.pl  
www.el-team.com.pl

## PORTUGAL

### Duarte Neves, Lda

Qta. Estrangeiros, Rua D 78  
2665-601 Venda do Pinheiro  
Phone +351 219 668100  
info@duarteneves.pt  
www.duarteneves.pt

## QATAR

### Greentec Automation DMCC

Office no. 1002, SABA Tower 1  
Cluster E Jumeirah Lakes Tower  
P.O. Box 346075  
DUBAI  
Phone +971 4551 6092  
Fax +971 4551 6073  
info@greentec-automation.com  
www.greentec-automation.com

## ROMANIA

### Unilux International Srl

Bd. Libertatii, nr. 4, bl. 117 et.7 ap 19  
ap. 19, Sector 4, 040128 Bucuresti  
Phone +4021 3177801  
contact@uniluxinternational.ro  
www.uniluxinternational.ro

## RUSSIA

### Marbel LLC

Mitrofan'evskoe shosse, 2,  
korp. 2, office 201  
190005 St. Petersburg  
Phone +7 812 644 6789  
theben@marbel.ru  
www.marbel.ru

## SAUDI ARABIA

### Anwar Al-Wessam Est.

Asad bin Al-furat st.  
P. O. Box 23521, Riyadh 11436  
Phone +966 1 405 5942  
info@al-wessam.com  
www.al-wessam.com

## SERBIA

### SOBEL d.o.o.

Ustanicka 125-1  
11000 Belgrad  
Phone +381 11 3087 507  
office@sobel.rs  
www.sobel.rs

## SINGAPORE

### ITE Electric Systems Co. Pte. Ltd.

ITE Electric Building  
1, Harrison Road 01-01,  
Singapore 369652  
Phone +65 6 285 2233  
ite@ite.com.sg  
www.ite.com.sg

## SLOVENIA

### MTS International d.o.o.

Perhavčeva ul. 15c, 2000 Maribor  
Phone +386 26612001  
info@mtsi.si  
www.mtsi.si

## SLOVAKIA

### Elektro-System-Technik, s.r.o.

Mnesická 11  
91501 Nové Mesto nad Váhom  
Phone +421 327740814  
info@est-slovensko.sk  
www.est-slovensko.sk

## SOUTH AFRICA

### Suparule Sa (Pty) Ltd

P.O. Box 76128, 2144 Wendywood  
Phone +27 11 4529800  
steve@suparule.co.za  
www.suparule.co.za

## SPAIN

### Guijarro Hermanos S.L.

Polig. Ind. Virgen De  
Butarque Isaac Peral 6  
28914 Leganes (Madrid)  
Phone +34 91 6870022  
theben@guijarrohermanos.es  
www.guijarrohermanos.es

## SYRIA

### Greentec Automation DMCC

Office no. 1002, SABA Tower 1  
Cluster E Jumeirah Lakes Tower  
P.O. Box 346075  
DUBAI  
Phone +971 4551 6092  
Fax +971 4551 6073  
info@greentec-automation.com  
www.greentec-automation.com

## TAIWAN

### Canaan Electric Corp.

6F-5, No.63, Sec. 2  
Chang An East Road  
104 Taipei / Taiwan  
Phone +886 2 25082331  
sales@canaan-elec.com.tw  
www.canaan-elec.com.tw

## THAILAND

### Technology Instruments Co Ltd

549/9 Onnut Rd.,  
Pravet 208/132-137, Bangkok 10250  
Phone +662 743 8888  
ttic@inet.co.th  
www.tic.co.th

## TUNESIA

### ELECTRIC BUSINESS AFRICA (EBA)

Zone Industrielle "Morize" BP 65  
2090 MORNAG  
Phone +216 79350955  
tfe.abelafrique@topnet.tn  
www.abelafrique.com

## TURKEY

### Gökhan Elektrik

Perpa Elektrokent Is Merkezi A  
A Blok K.8 No. 692-694  
80270 Okmeydanı/İstanbul  
Phone +90 212 221 32 36  
ufuk@gokhanelektrik.com.tr  
www.gokhanelektrik.com.tr

## UKRAINE

### KVK-Elektro, Ltd.

28 Pyrogivskyy shlykh Str., 03083 Kyiv  
Phone +380 44 4962883  
info@kvk.kiev.ua  
www.kvk-elektro.com.ua

## UNITED ARAB EMIRATES

### Gama Electrical Trading Co.

POB 22185, Sharjah  
Phone +971 6 533 5453  
info@gama.ae  
www.gama.ae

## USA

### LUMENITE CONTROL

Techn Inc., 2331 North 17th. Av.  
Franklin Park, Illinois 60131  
Phone +1 847 4551450  
customerservice@lumenite.com  
www.lumenite.com

Theben is member of:



Follow Theben on the Internet:



# theben

Theben AG  
Hohenbergstraße 32  
72401 Haigerloch  
Phone +49 7474 692-0  
Fax +49 7474 692-150  
info@theben.de  
www.theben.de

**Service Hotline**  
hotline@theben.de  
+49 7474 692-369  
Monday to Thursday 7.00 am to 6.00 pm,  
Fr 7.00 am to 4.00 pm

9900600 0318 We reserve the right to make technical modifications and improvements.

