

SKOFF

OŚWIETLENIE MEBLOWE LED

LED FURNITURE-MOUNTED LIGHTING

LED MÖBELLEUCHTEN

NÁBYTKOVÁ SVÍTIDLA LED

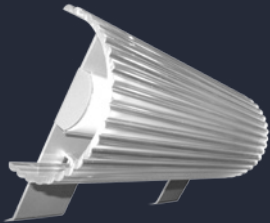



SKOFF DESIGN

OBJAŚNIENIA

Explanatory notes • Erklärungen • Vysvětlení







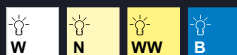



Rodzaj powierzchni • Surface finish • Oberfläche • Druh povrchu

	Chrom Chrome Chrom Chrom		Lustro (INOX) Mirror (INOX) Spiegel (INOX) Zrcadlo (INOX)		Transparentny Transparent Transparent Transparentní		Nikiel szlif Brushed nickel Nickel geschliffen Nikiel brus		Szampański Champagne Champagne Šampaňská
	Szlif (INOX) Stainless steel (INOX) Edelstahl geschliffen (INOX) Bрус (INOX)		Czarny Black Schwarz Černý		Mosiądz starzony Aged brass Altmessing Patinovaná mosaz		Aluminium Aluminium Aluminium Hliník		

Kolor emisji światła • Colour of light • Lichtfarbe • Barva emise světla:



W Zimny biały • Cool white • Kaltweiß • Studená bílá
 WW Ciepły biały • Warm white • Warmweiß • Teplá bílá
 N Neutralny • Neutral • Neutral • Neutrální
 B Niebieski • Blue • Blau • Modrá

3,8 W Moc • Power • Leistung • Výkon	12 V DC Napięcie znamionowe • Rated voltage • Nennspannung • Jmenovitě napětí	Ra>80 Współczynnik oddawania barw Ra (CRI) • Colour rendering index Ra (CRI) • Farbwiedergabeindex Ra (CRI) • Index podání barev Ra (CRI)	6000–6500 K Temperatura barwowa [K] • Color temperature [K] • Farbtemperatur [K] • Barevná teplota [K]
 I Klasa ochronności I Protection class I Schutzklasse I Třída ochrany	 II Klasa ochronności II Protection class II Schutzklasse II Třída ochrany	 III Klasa ochronności III Protection class III Schutzklasse III Třída ochrany	 Źródło światła LED LED light source LED-Lichtquelle Zdroj světla LED
 120° Kąt świecenia Beam angle Lichtwinkel Úhel svícení	255 lm Strumień świetlny Luminous flux Lichtstrom Světelný tok	 LED Klasa efektywności energetycznej Energy efficiency class Energieeffizienzklasse Třída energetické účinnosti	 Urządzenie do lamp niezależne Independent lampgear Externes Gerät für Lampen Zařízení k světelným zdrojům, nezávislé
 Transformator bezpieczeństwa odporny na zwarcie i przeciążenia • Short-circuit proof safety transformer • Sicherheitstransformator geschützt gegen Kurzschluss • Bezpečnostní transformátor odolný proti zkratu	IP20 Ochrona przed wnikaniem ciał obcych. Brak ochrony przed szkodliwym wnikaniem wody • Protection against ingress of foreign bodies. Not protected from harmful water ingress • Geschützt gegen feste Fremdkörper. Kein Schutz gegen Beschädigung durch Wasser • Chráněno proti proniknutí cizích pevných těles. Není chráněno proti škodlivému průniku vody	IP44 Ochrona przed bryzgami wody • Protection against water spray • Schutz gegen allseitiges Spritzwasser • Chráněno proti stříkající vodě	 Zgodność z dyrektywami Unii Europejskiej • Compliance with EU Directives • In Übereinstimmung mit den Verordnungen der EU • Shodnost s příslušnými směrnicemi Evropské unie
 Pełna ochrona przed wnikaniem pyłów i ciał stałych oraz głębokim zanurzeniem w wodzie • Total protection againsts solid objects, dust ingress and deep immersion in water • Schtaubdicht und gegen dauerndes Untertauchen geschützt • Plně chráněno proti proniknutí prachu, cizích pevných těles a proti ponoření do vody			

SPIS TREŚCI

Table of Contents • Inhaltsverzeichnis • Obsah

LAMPY PODSZAFKOWE 6	ZASILACZE NAPIĘCIOWE OPRAW LED 12 V 32
UNDER-CABINET LAMPS	12 V CV POWER SUPPLIES FOR LED LUMINAIRES
UNTERBAULEUCHTEN	NETZTEILE FÜR LED-LEUCHTEN 12 V
PODSKRÍNKOVÉ OSVETLEN	NAPĚŤOVÉ NAPAJEČE PRO LED SVÍTIDLA 12 V
OPRAWY MEBLOWE 10	ZASILACZE NAPIĘCIOWE OPRAW LED 34
FURNITURE-MOUNTED LUMINAIRES	POWER SUPPLIES FOR LED LUMINAIRES
MÖBELEINBAULEUCHTEN	NETZTEILE FÜR LED-LEUCHTEN
NÁBYTKOVÁ SVÍTIDLA	NAPĚŤOVÉ NAPAJEČE PRO LED SVÍTIDLA
LAMPY NAŚCIENNE I WYSIĘGNIKOWE 16	ZASILACZE PRĄDOWE OPRAW LED 35
WALL-MOUNTED LAMPS AND ARM LAMPS	LED LUMINAIRE CURRENT UNITS
WANDLEUCHTEN UND AUFBAULEUCHTEN	KONSTANTSTROM NETZTEILE FÜR LED-LEUCHTEN
NASTĚNNÁ A VÝLOŽNÍKOVÁ SVÍTIDLA	PROUDOVÉ NAPAJEČE PRO LED SVÍTIDLA
LISTWY I TUBY LED 20	TRANSFORMATORY ELEKTRONICZNE DO OPRAW HALOGENOWYCH 36
LED PROFILES AND TUBES	ELECTRONIC TRANSFORMERS FOR HALOGEN LUMINAIRES
LED-LEISTEN UND LED-RÖHRE	ELEKTRONISCHE TRANSFORMATOREN FÜR HALOGENLEUCHTEN
LIŠTY A TUBY LED	ELEKTRONICKÉ TRANSFORMÁTORY PRO HALOGENOVÁ SVÍTIDLA
TAŚMA LED 23	AKCESORIA 37
LED STRIP	ACCESSORIES
LED-STREIFEN	ZUBEHÖR
PÁSKY LED	PŘÍSLUŠENSTVÍ
RAMKI PÓŁKI MEBLOWE LED 24	MATERIAŁY REKLAMOWE 40
LLED FURNITURE SHELF AND FRAMES	ADVERTISING MATERIALS
LLED-LEUCHTREGAL UND RAHMEN	WERBEMATERIAL
NÁBYTKOVÉ POLICE A RÁMKY LED	REKLAMNÍ MATERIÁLY
OPRAWY MEBLOWE HALOGENOWE 26	INDEKS 42
FURNITURE HALOGEN FITTINGS	
HALOGENMÖBELLEUCHTEN	
HALOGENOVÁ NÁBYTKOVÝ SVÍTIDLA	
ZASILACZE NAPIĘCIOWE OPRAW LED 10 V 30	
10 V CV POWER SUPPLIES FOR LED LUMINAIRES	
NETZTEILE FÜR LED-LEUCHTEN 10 V	
NAPĚŤOVÉ NAPAJEČE PRO LED SVÍTIDLA 10 V	

UNIKATOWE ROZWIĄZANIE

Najlepsza inwestycja w światło!

THE UNIQUE SOLUTION
The best investment in light!

EINZIGARTIGE LÖSUNG
Die beste Investition ins Licht!

UNIKÁTNÍ ŘEŠENÍ
Nejlepší investice do světla!

OŚWIETLENIE MEBLOWE

Dobre oświetlenie znacząco wpływa na postrzeganie przedmiotów i ich otoczenia. Od niego zależy, czy dane miejsce będzie interesujące i zachęcające do wejścia. Oświetlenie stworzy odpowiednią atmosferę do efektywnej pracy i wypoczynku, dzięki czemu każda chwila nabierze blasku.

Udoskonal swoje wnętrza poprzez dobór właściwego oświetlenia do mebli. Firma SKOFF oferuje szeroką gamę produktów oświetleniowych do mebli w salonie, kuchni i łazience. Stworzone są one z najwyższej jakości materiałów, z użyciem najnowszej technologii oszczędzania energii – LED.

FURNITURE-MOUNTED LIGHTING

Good lighting has a major effect on your perception of items and their surroundings. It determines whether the given location will be interesting and encouraging to come inside. The lighting will create the right atmosphere for efficient work and for relaxing, making each moment shine for you.

Improve your interiors and choose the right lighting for your furniture. SKOFF offers a broad range of lighting products for living room, kitchen and bathroom furniture. They are made of best quality materials, using LED as the most advanced energy-efficient technology.

MÖBELLEUCHTEN

Eine gute Beleuchtung wirkt sich erheblich auf die Wahrnehmung von Gegenständen und ihrer Umgebung aus. Sie ist entscheidend dafür, ob ein Raum interessant und einladend wirkt. Mit der Beleuchtung wird die Raumatmosphäre für effektive Arbeit und für Erholung gestaltet. So wird jedem Moment ein besonderer Glanz verliehen.

Gestalte deine Innenräume mit der perfekten Möbelbeleuchtung. SKOFF bietet ein umfassendes Möbelbeleuchtungsprogramm für Wohnzimmer, Küche und Bad. Die Produkte werden aus hochqualitativen Stoffen und mithilfe der neuesten energiesparenden LED-Technologie hergestellt.

NÁBYTKOVÉ OSVĚTLENÍ

Dobré osvětlení značně ovlivňuje percepci předmětů a okolí. Od něj závisí, zda dané místo bude vypadat zajímavé a zda bude zvat hosty dovnitř. Osvětlení vytvoří vhodnou atmosféru pro efektivnější práci a odpočinek, díky čemuž každá chvíle bude mít výjimečné kouzlo.

Zdokonalte svůj interiér díky správné volbě nábytkového osvětlení. Firma SKOFF nabízí velký výběr nábytkového osvětlení pro nábytek v obývacím pokoji, kuchyni, koupelně. Osvětlení je vyrobeno z nejkvalitnějších materiálů, s použitím nejnovější úsporné technologie – LED.

MADE IN POLAND

FIRMA LOKALNA O ZASIĘGU GLOBALNYM

SKOFF jest polskim producentem wyrobów oświetleniowych i osprzętu elektrotechnicznego. Swoją działalność skupia na dostarczaniu rozwiązań zarówno dla profesjonalistów, jak i zwykłych konsumentów.

A LOCAL COMPANY WITH A GLOBAL REACH

SKOFF is a Polish manufacturer of lighting products and electrical fixtures. The company focuses on delivering solutions to professionals as well as ordinary consumers.

EINE LOKALE FIRMA MIT GLOBALER REICHWEITE

SKOFF ist ein polnischer Hersteller von Beleuchtung und Elektrotechnik-Zubehör. Der Schwerpunkt der Firma liegt in der Bereitstellung von Lösungen sowohl für Profis, als auch für gewöhnliche Verbraucher.

LOKÁLNÍ FIRMA S GLOBÁLNÍM DOSAHEM

SKOFF je polský výrobce svítidel a elektrotechnického zařízení. Soustředí se zvláště na poskytování řešení jak pro profesionály, tak pro maloobchodní zákazníky.

SKOFF

ul. Legionów 243 D
43-500 Czechowice-Dziedzice
POLAND

www.skoff.pl



LAMPY PODSZAFKOWE

UNDER-CABINET LAMPS

UNTERBAULEUCHTEN

PODSKRÍNKOVÉ
OSVETLEN



RETANGO typ LLP7

TRIANGO typ LLT2

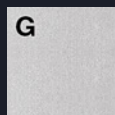
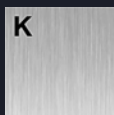
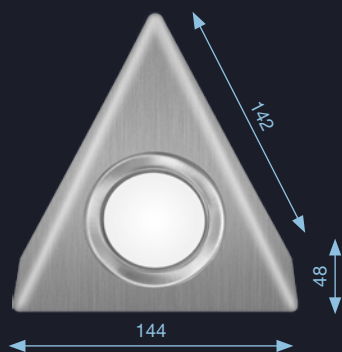

3,8 W	12 V DC	IP20	Ra>80		
120°	255 lm 227 lm	6000 K 3000 K	LED		

Do podłączenia oprawy należy użyć zasilacza 12 V z rozdzielaczem • 12 V Power supply with a splitter should be used for light fixture connection • Zum Anschließen der Leuchte verwenden Sie bitte ein Netzteil 12 V mit Verteiler • Pro připojení objímky použijte zdroj napájení 12 V s rozdělovačem

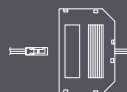

TRIANGO typ LLT2w

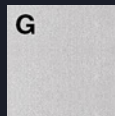
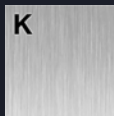
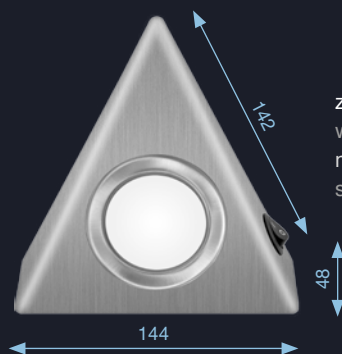

z wyłącznikiem
with switch
mit Schalter
s vypínačem

3,8 W	12 V DC	IP20	Ra>80		
120°	255 lm 227 lm	6000 K 3000 K	LED		

Do podłączenia oprawy należy użyć zasilacza 12 V z rozdzielaczem • 12 V Power supply with a splitter should be used for light fixture connection • Zum Anschließen der Leuchte verwenden Sie bitte ein Netzteil 12 V mit Verteiler • Pro připojení objímky použijte zdroj napájení 12 V s rozdělovačem

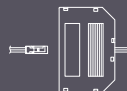



TRIANGO typ LLT7

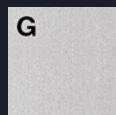
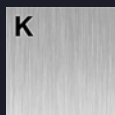
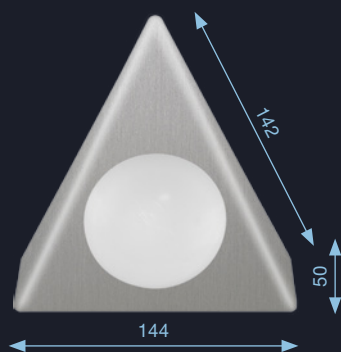

3,8 W	12 V DC	IP20	Ra>80		CE
120°	228 lm 205 lm	6000 K 3000 K	LED		

Do podłączenia oprawy należy użyć zasilacza 12 V z rozdzielaczem • 12 V Power supply with a splitter should be used for light fixture connection • Zum Anschließen der Leuchte verwenden Sie bitte ein Netzteil 12 V mit Verteiler • Pro připojení objímky použijte zdroj napájení 12 V s rozdělovačem

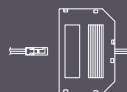

TRIANGO typ LLT7w

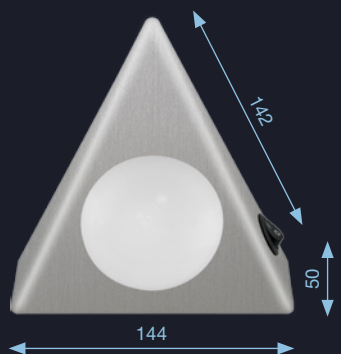

z wyłącznikiem
with switch
mit Schalter
s vypínačem

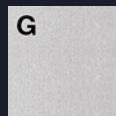
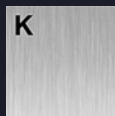

3,8 W	12 V DC	IP20	Ra>80		CE
120°	228 lm 205 lm	6000 K 3000 K	LED		

Do podłączenia oprawy należy użyć zasilacza 12 V z rozdzielaczem • 12 V Power supply with a splitter should be used for light fixture connection • Zum Anschließen der Leuchte verwenden Sie bitte ein Netzteil 12 V mit Verteiler • Pro připojení objímky použijte zdroj napájení 12 V s rozdělovačem

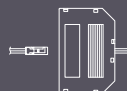



RETANGO typ LLP7

RETANGO typ LLP2

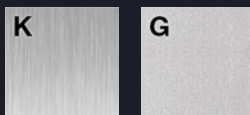
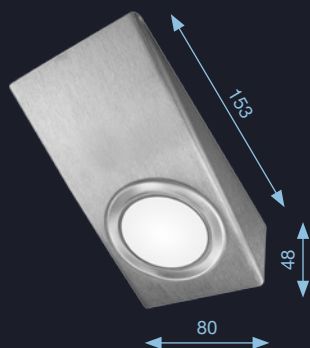

3,8 W	12 V DC	IP20	Ra>80		
120°	255 lm 227 lm	6000 K 3000 K	LED		

Do podłączenia oprawy należy użyć zasilacza 12 V z rozdzielnicem • 12 V Power supply with a splitter should be used for light fixture connection • Zum Anschließen der Leuchte verwenden Sie bitte ein Netzteil 12 V mit Verteiler • Pro připojení objímky použijte zdroj napájení 12 V s rozdělovačem

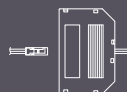

RETANGO typ LLP2w

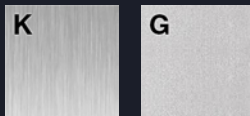
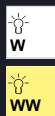
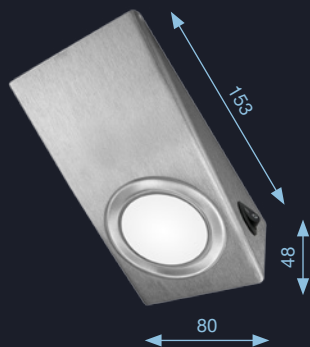

3,8 W	12 V DC	IP20	Ra>80		
120°	255 lm 227 lm	6000 K 3000 K	LED		

Do podłączenia oprawy należy użyć zasilacza 12 V z rozdzielnicem • 12 V Power supply with a splitter should be used for light fixture connection • Zum Anschließen der Leuchte verwenden Sie bitte ein Netzteil 12 V mit Verteiler • Pro připojení objímky použijte zdroj napájení 12 V s rozdělovačem

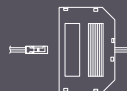

z wyłącznikiem
with switch
mit Schalter
s vypínačem

QUADRATO typ LLK7

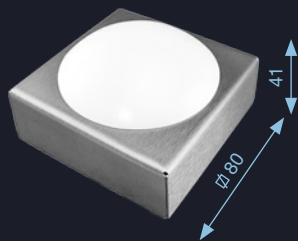
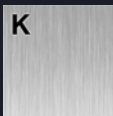

3,8 W	12 V DC	IP20	Ra>80		
120°	228 lm 205 lm	6000 K 3000 K	LED		

Do podłączenia oprawy należy użyć zasilacza 12 V z rozdzielaczem • 12 V Power supply with a splitter should be used for light fixture connection • Zum Anschließen der Leuchte verwenden Sie bitte ein Netzteil 12 V mit Verteiler • Pro připojení objímky použijte zdroj napájení 12 V s rozdělovačem

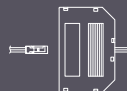

RETANGO typ LLP7

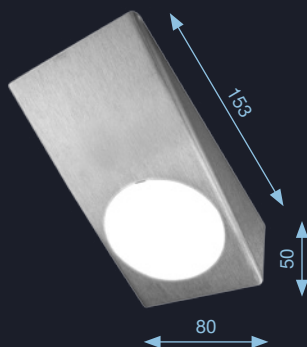
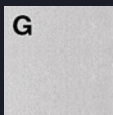
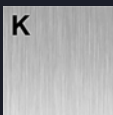

3,8 W	12 V DC	IP20	Ra>80		
120°	228 lm 205 lm	6000 K 3000 K	LED		

Do podłączenia oprawy należy użyć zasilacza 12 V z rozdzielaczem • 12 V Power supply with a splitter should be used for light fixture connection • Zum Anschließen der Leuchte verwenden Sie bitte ein Netzteil 12 V mit Verteiler • Pro připojení objímky použijte zdroj napájení 12 V s rozdělovačem

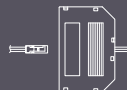

RETANGO typ LLP7w

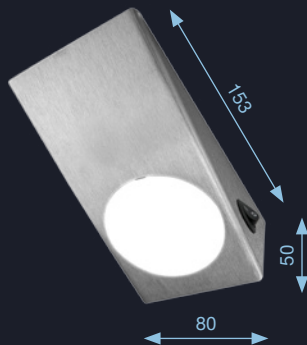
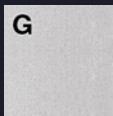
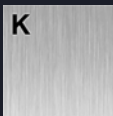
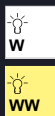

z wyłącznikiem
with switch
mit Schalter
s vypínačem

3,8 W	12 V DC	IP20	Ra>80		
120°	228 lm 205 lm	6000 K 3000 K	LED		

Do podłączenia oprawy należy użyć zasilacza 12 V z rozdzielaczem • 12 V Power supply with a splitter should be used for light fixture connection • Zum Anschließen der Leuchte verwenden Sie bitte ein Netzteil 12 V mit Verteiler • Pro připojení objímky použijte zdroj napájení 12 V s rozdělovačem

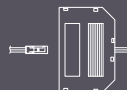

OPRAWY MEBLOWE

FURNITURE-MOUNTED LUMINAIRES

MÖBELEINBAULEUCHTEN

NÁBYTKOVÁ SVÍTIDLA



ROTONDO typ OML2

ROTONDO typ OML8

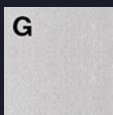

1,8 W	12 V DC	IP20	Ra>80		CE
120°	130 lm 115 lm	6000 K 3000 K	LED		

Do podłączenia oprawy należy użyć zasilacza 12 V z rozdzielaczem • 12 V Power supply with a splitter should be used for light fixture connection • Zum Anschließen der Leuchte verwenden Sie bitte ein Netzteil 12 V mit Verteiler • Pro připojení objímky použijte zdroj napájení 12 V s rozdělovačem

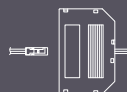

ROTONDO typ OML8-1

New!

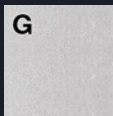

1,8 W	12 V DC	IP20	Ra>80		CE
120°	130 lm 115 lm	6000 K 3000 K	LED		

Do podłączenia oprawy należy użyć zasilacza 12 V z rozdzielaczem • 12 V Power supply with a splitter should be used for light fixture connection • Zum Anschließen der Leuchte verwenden Sie bitte ein Netzteil 12 V mit Verteiler • Pro připojení objímky použijte zdroj napájení 12 V s rozdělovačem

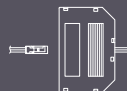

ROTONDO typ OML9



14

∅ 58

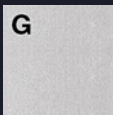

1,8 W	12 V DC	IP20	Ra>80		
120°	130 lm 115 lm	6000 K 3000 K	LED		

Do podłączenia oprawy należy użyć zasilacza 12 V z rozdzielaczem • 12 V Power supply with a splitter should be used for light fixture connection • Zum Anschließen der Leuchte verwenden Sie bitte ein Netzteil 12 V mit Verteiler • Pro připojení objímky použijte zdroj napájení 12 V s rozdělovačem

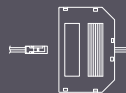

ROTONDO typ OML9-1



14

∅ 58

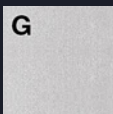

1,8 W	12 V DC	IP20	Ra>80		
120°	130 lm 115 lm	6000 K 3000 K	LED		

Do podłączenia oprawy należy użyć zasilacza 12 V z rozdzielaczem • 12 V Power supply with a splitter should be used for light fixture connection • Zum Anschließen der Leuchte verwenden Sie bitte ein Netzteil 12 V mit Verteiler • Pro připojení objímky použijte zdroj napájení 12 V s rozdělovačem

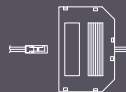

ROTONDO typ OML2



13
22

∅ 75

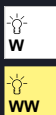
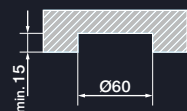

3,8 W	12 V DC	IP20	Ra>80		
120°	255 lm 227 lm	6000 K 3000 K	LED		

ROTONDO typ OML2-1

New!

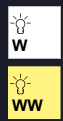

Ø75

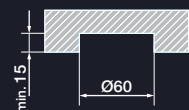

3,8 W	12 V DC	IP20	Ra>80		
120°	255 lm 227 lm	6000 K 3000 K	LED		

ROTONDO typ OML3



Ø75

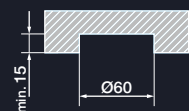

1,8 W	12 V DC	IP20	Ra>80		
120°	130 lm 120 lm	6000 K 3000 K	LED		

ROTONDO typ OML3-1

New!

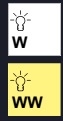

Ø75

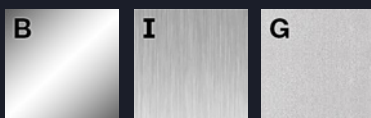
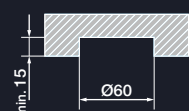

1,8 W	12 V DC	IP20	Ra>80		
120°	130 lm 120 lm	6000 K 3000 K	LED		

COSMO typ OML7P

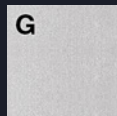
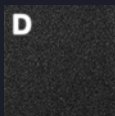
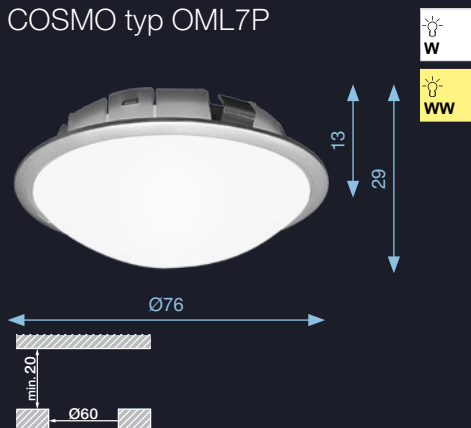

3,8 W	12 V DC	IP20	Ra>80		
120°	228 lm 205 lm	6000 K 3000 K	LED		



ROTONDO typ OML8-1

PUNKTO typ OML5

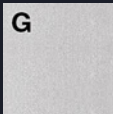
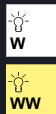
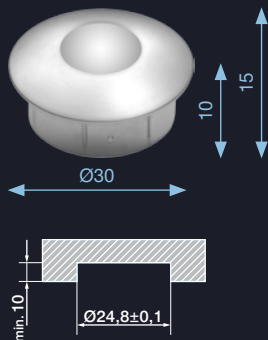

1 W	10 V DC	IP20	Ra>80		
50°	23 lm 21 lm	6000 K 3000 K	LED		

Do podłączenia oprawy należy użyć zasilacza 10 V z rozdzielnikiem • 10 V Power supply with a splitter should be used for light fixture connection • Zum Anschließen der Leuchte verwenden Sie bitte ein Netzteil 10 V mit Verteiler • Pro připojení objímky použijte zdroj napájení 10 V s rozdělovačem

PUNKTO typ OMLd5

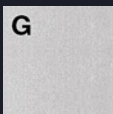
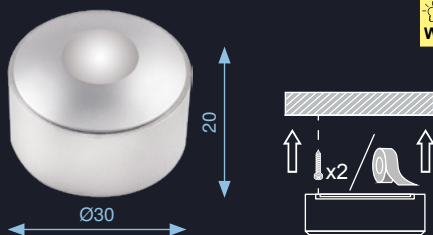

1 W	10 V DC	IP20	Ra>80		
50°	23 lm 21 lm	6000 K 3000 K	LED		

Do podłączenia oprawy należy użyć zasilacza 10 V z rozdzielnikiem • 10 V Power supply with a splitter should be used for light fixture connection • Zum Anschließen der Leuchte verwenden Sie bitte ein Netzteil 10 V mit Verteiler • Pro připojení objímky použijte zdroj napájení 10 V s rozdělovačem

PUNKTO typ OML6

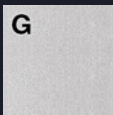
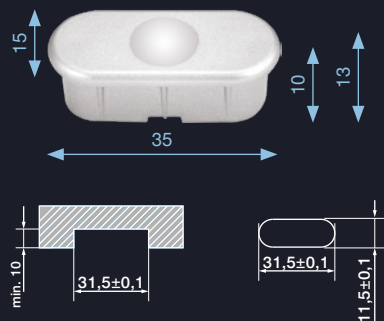

0,5 W	10 V DC	IP20	Ra>80		
35°	15 lm 13 lm	6000 K 3000 K	LED		

Do podłączenia oprawy należy użyć zasilacza 10 V z rozdzielnikiem • 10 V Power supply with a splitter should be used for light fixture connection • Zum Anschließen der Leuchte verwenden Sie bitte ein Netzteil 10 V mit Verteiler • Pro připojení objímky použijte zdroj napájení 10 V s rozdělovačem

Clip LED typ KL1

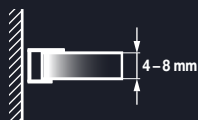
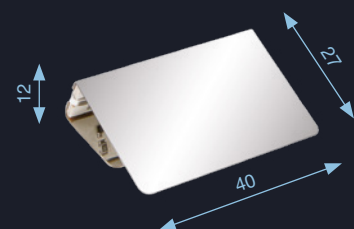

0,2 W	10 V DC	IP20	Ra>80	
	LED	6000 K 3000 K		

Do podłączenia oprawy należy użyć zasilacza 10 V z rozdzielnicem • 10 V Power supply with a splitter should be used for light fixture connection • Zum Anschließen der Leuchte verwenden Sie bitte ein Netzteil 10 V mit Verteiler • Pro připojení objímky použijte zdroj napájení 10 V s rozdělovačem

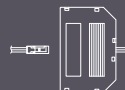

Clip LED typ KL2

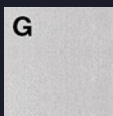
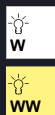
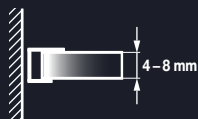
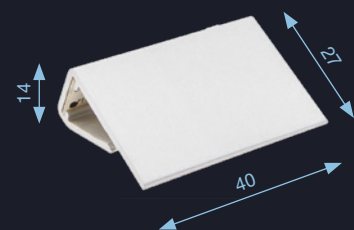

0,2 W	10 V DC	IP20	Ra>80	
	LED	6000 K 3000 K		

Do podłączenia oprawy należy użyć zasilacza 10 V z rozdzielnicem • 10 V Power supply with a splitter should be used for light fixture connection • Zum Anschließen der Leuchte verwenden Sie bitte ein Netzteil 10 V mit Verteiler • Pro připojení objímky použijte zdroj napájení 10 V s rozdělovačem

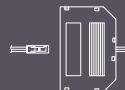

Clip LED typ KL3

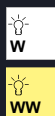
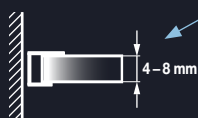
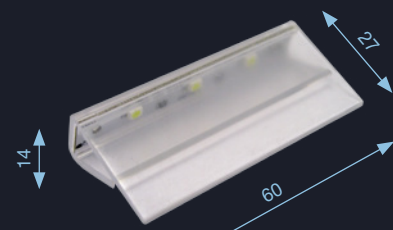

0,24 W	12 V DC	IP20	Ra>80	
	LED	6000 K 3000 K		

Do podłączenia oprawy należy użyć zasilacza 12 V z rozdzielnicem • 12 V Power supply with a splitter should be used for light fixture connection • Zum Anschließen der Leuchte verwenden Sie bitte ein Netzteil 12 V mit Verteiler • Pro připojení objímky použijte zdroj napájení 12 V s rozdělovačem

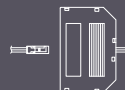

LAMPY NAŚCIENNE I WYSIĘGNIKOWE

WALL-MOUNTED LAMPS
AND ARM LAMPS

WANDLEUCHTEN UND
AUFBAULEUCHTEN

NASTĚNNÁ A VÝLOŽNÍKOVÁ
SVÍTIDLA



PERLA CLASSIC typ LN7



NATALI CLASSIC typ LN10

PERLA typ LN11

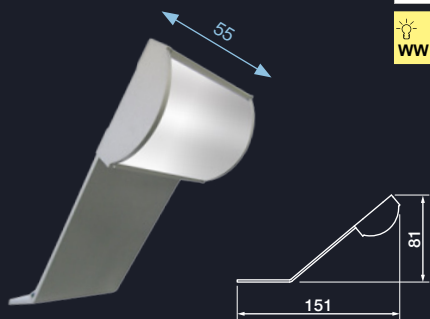

4,6 W	12 V DC	IP44	Ra>80		
120°	202 lm 182 lm	6000 K 3000 K	LED		

Do podłączenia oprawy należy użyć zasilacza 12 V z rozdzielaczem • 12 V Power supply with a splitter should be used for light fixture connection • Zum Anschließen der Leuchte verwenden Sie bitte ein Netzteil 12 V mit Verteiler • Pro připojení objímky použijte zdroj napájení 12 V s rozdělovačem

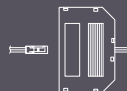

PERLA CLASSIC typ LN7

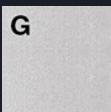
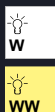
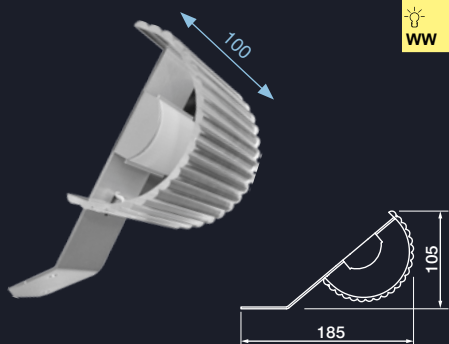

4,6 W	12 V DC	IP44	Ra>80		
120°	184 lm 165 lm	6000 K 3000 K	LED		

Do podłączenia oprawy należy użyć zasilacza 12 V z rozdzielaczem • 12 V Power supply with a splitter should be used for light fixture connection • Zum Anschließen der Leuchte verwenden Sie bitte ein Netzteil 12 V mit Verteiler • Pro připojení objímky použijte zdroj napájení 12 V s rozdělovačem

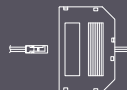

PERLA CLASSIC MAX typ LN8

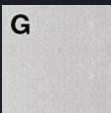
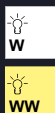
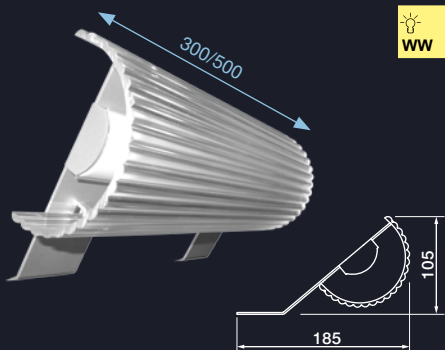

12 V DC	IP44	120°	Ra>80		
300 mm	5,0 W	260 lm 234 lm	6000 K 3000 K	LED	
500 mm	9,4 W	404 lm 363 lm			

Do podłączenia oprawy należy użyć zasilacza 12 V z rozdzielaczem • 12 V Power supply with a splitter should be used for light fixture connection • Zum Anschließen der Leuchte verwenden Sie bitte ein Netzteil 12 V mit Verteiler • Pro připojení objímky použijte zdroj napájení 12 V s rozdělovačem

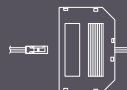

CLARO typ LN1

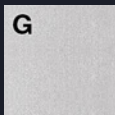

290 mm	5,8 W	365 lm	6000 K 3000 K	12 V DC	LED	Ra>80
	5,8 W	328 lm		IP44		
325 mm	3,6 W	170 lm	3800 K	120°	LED	CE

Do podłączenia oprawy należy użyć zasilacza 12 V z rozdzielaczem • 12 V Power supply with a splitter. should be used for light fixture connection • Zum Anschließen der Leuchte verwenden Sie bitte ein Netzteil 12 V mit Verteiler • Pro připojení objímky použijte zdroj napájení 12 V s rozdělovačem

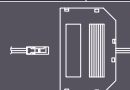

NATALI typ LN9

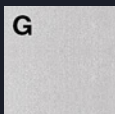
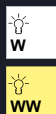
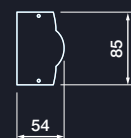

289 mm	5,8 W	300 lm 270 lm	6000 K 3000 K	230 V AC	LED	Ra>80
454 mm	9,4 W	507 lm 456 lm	6000 K 3000 K	IP44		
624 mm	13,0 W	712 lm 640 lm	6000 K 3000 K	120°	LED	CE

NATALI CLASSIC typ LN10

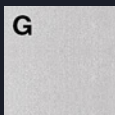
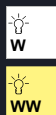
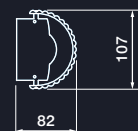
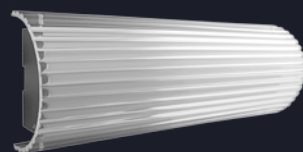

325 mm	5,8 W	270 lm 243 lm	6000 K 3000 K	230 V AC	LED	Ra>80
490 mm	9,4 W	456 lm 410 lm	6000 K 3000 K	IP44		
660 mm	13,0 W	640 lm 576 lm	6000 K 3000 K	120°	LED	CE



CLARO typ LN1



NATALI typ LN9

LISTWY I TUBY LED

LED PROFILES AND TUBES

LED-LEISTEN UND LED-RÖHRE

LIŠTY A TUBY LED



IVO typ LL7

IVO typ LL7

New!

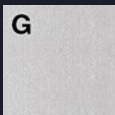
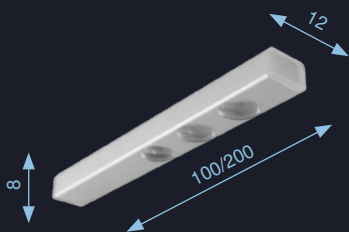

100 mm	2,4 W	6000 K 3000 K	12 V DC	LED
	7,2 W	3800 K	IP20	III
200 mm	2,4 W	6000 K 3000 K	Ra>80	LED
	7,2 W	3800 K		CE

Do podłączenia oprawy należy użyć zasilacza 12 V z rozdzielaczem • 12 V Power supply with a splitter should be used for light fixture connection • Zum Anschließen der Leuchte verwenden Sie bitte ein Netzteil 12 V mit Verteiler • Pro připojení objmkij použijte zdroj napájení 12 V s rozdělovačem

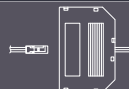

LEO typ LL1

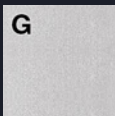
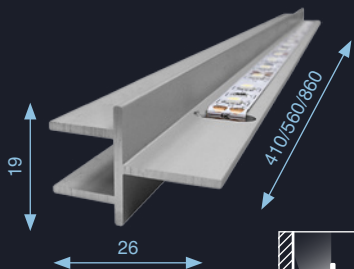

410 mm	3,4 W	324 lm 292 lm	6000 K 3000 K	12 V DC	LED	Ra>80
560 mm	4,8 W	446 lm 400 lm	6000 K 3000 K	IP20	III	
860 mm	7,7 W	686 lm 617 lm	6000 K 3000 K	2x108°	LED	CE

Do podłączenia oprawy należy użyć zasilacza 12 V z rozdzielaczem • 12 V Power supply with a splitter should be used for light fixture connection • Zum Anschließen der Leuchte verwenden Sie bitte ein Netzteil 12 V mit Verteiler • Pro připojení objmkij použijte zdroj napájení 12 V s rozdělovačem



LEO typ LL2

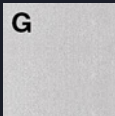
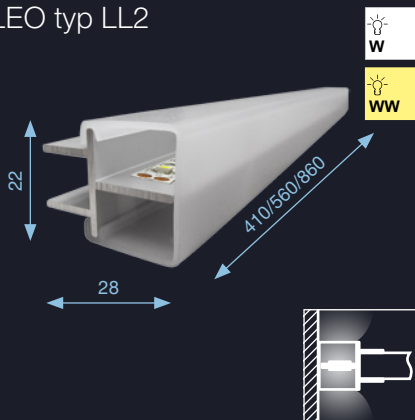

410 mm	3,4 W	230 lm 207 lm	6000 K 3000 K	12 V DC	LED	Ra>80
560 mm	4,8 W	320 lm 288 lm	6000 K 3000 K	IP20	III	CE
860 mm	7,7 W	490 lm 441 lm	6000 K 3000 K	2x135°	A++ LED A	

Do podłączenia oprawy należy użyć zasilacza 12 V z rozdzielaczem • 12 V Power supply with a splitter should be used for light fixture connection • Zum Anschließen der Leuchte verwenden Sie bitte ein Netzteil 12 V mit Verteiler • Pro připojení objímky použijte zdroj napájení 12 V s rozdělovačem

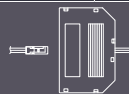

LEO typ LL5

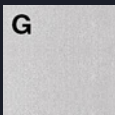
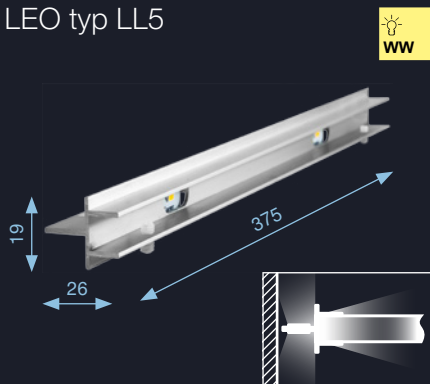

0,24 W	12 V DC	IP20	Ra>80	III	CE
2x100° 1x50°	6000 K 3000 K	LED	A++ LED A		

Do podłączenia oprawy należy użyć zasilacza 12 V z rozdzielaczem • 12 V Power supply with a splitter should be used for light fixture connection • Zum Anschließen der Leuchte verwenden Sie bitte ein Netzteil 12 V mit Verteiler • Pro připojení objímky použijte zdroj napájení 12 V s rozdělovačem

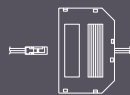

LEO typ LL6

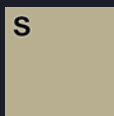
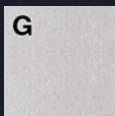
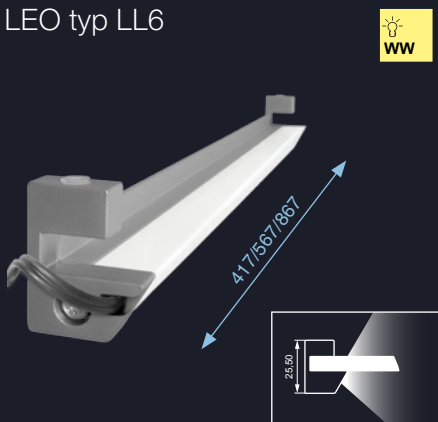

417 mm	3,8 W	242 lm 217 lm	6000 K 3000 K	12 V DC	LED	Ra>80
567 mm	5,2 W	368 lm 330 lm	6000 K 3000 K	IP20	III	CE
867 mm	8,1 W	581 lm 522 lm	6000 K 3000 K	120°	A++ LED A	

Do podłączenia oprawy należy użyć zasilacza 12 V z rozdzielaczem • 12 V Power supply with a splitter should be used for light fixture connection • Zum Anschließen der Leuchte verwenden Sie bitte ein Netzteil 12 V mit Verteiler • Pro připojení objímky použijte zdroj napájení 12 V s rozdělovačem

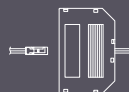

ROXY typ LL3

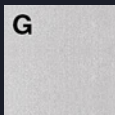
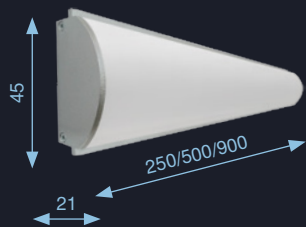

250 mm	5,0 W	315 lm 283 lm	6000 K 3000 K	12 V DC	LED	Ra>80
500 mm	10,1 W	636 lm 572 lm	6000 K 3000 K	IP44	III	CE
900 mm	18,7 W	1180 lm 1060 lm	6000 K 3000 K	120°	A+> A LED	

PABLO typ TL1

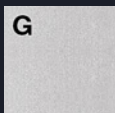
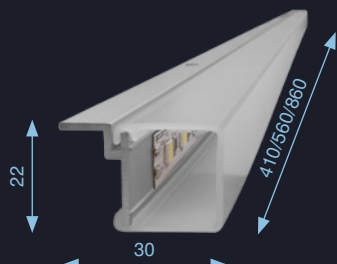

410 mm	3,6 W 3,6 W 5 W	227 lm 204 lm 210 lm	6000 K 3000 K 3800 K	12 V DC	LED	Ra>80
560 mm	5 W 5 W 7,2 W	345 lm 310 lm 302 lm	6000 K 3000 K 3800 K	IP44	III	CE
860 mm	7,9 W 7,9 W 11,5 W	545 lm 490 lm 483 lm	6000 K 3000 K 3800 K	148°	A+> A LED	

Do podłączenia oprawy należy użyć zasilacza 12 V z rozdzielaczem • 12 V Power supply with a splitter, should be used for light fixture connection • Zum Anschließen der Leuchte verwenden Sie bitte ein Netzteil 12 V mit Verteiler • Pro připojení objímky použijte zdroj napájení 12 V s rozdělovačem

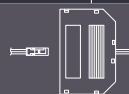

PABLO typ TL4

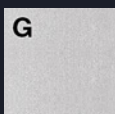
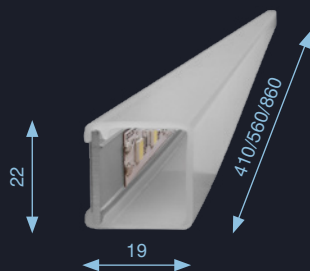

410 mm	3,6 W 3,6 W 5 W	227 lm 204 lm 210 lm	6000 K 3000 K 3800 K	12 V DC	LED	Ra>80
560 mm	5 W 5 W 7,2 W	345 lm 310 lm 302 lm	6000 K 3000 K 3800 K	IP44	III	CE
860 mm	7,9 W 7,9 W 11,5 W	545 lm 490 lm 483 lm	6000 K 3000 K 3800 K	148°	A+> A LED	

Do podłączenia oprawy należy użyć zasilacza 12 V z rozdzielaczem • 12 V Power supply with a splitter, should be used for light fixture connection • Zum Anschließen der Leuchte verwenden Sie bitte ein Netzteil 12 V mit Verteiler • Pro připojení objímky použijte zdroj napájení 12 V s rozdělovačem

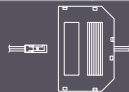

TAŚMA LED



LED STRIP
LED-STREIFEN
PÁSKY LED



Taśma LED



4,8 W	420 lm / m 390 lm / m 405 lm / m	6000 K 3000 K 3800 K	12 V DC	LED
9,6 W	780 lm / m 720 lm / m	6000 K 3000 K	IP20	LED
14,4 W	1240 lm / m 1140 lm / m 1200 lm / m	6000 K 3000 K 3800 K	Ra>80	III
21,6 W	1530 lm / m 1440 lm / m	6000 K 3000 K	CE	

Taśma LED SKOFF to znakomite uzupełnienie każdej domowej i komercyjnej przestrzeni. Jej zaletami są przede wszystkim wysoka jakość, zróżnicowanie dostępnych taśm pod względem ilości światła jakie dają - od 420 lm / m (taśma 4,8 W / m, 6000 K) do 1440 lm / m (taśma 21,6 W / m, 3000 K), gwarancja jednolitego świecenia do 5 m długości, niebywała łatwość montażu za pomocą taśmy dwustronnie klejącej marki 3M oraz 36-miesięczna gwarancja producenta*.

SKOFF LED strip light can be incorporated in any domestic or commercial space with great effect. Its key advantages include the high quality, variety in terms of light quantity – from 420 lm / m (4.8 W / m strip, 6000 K) to 1440 lm / m (21.6 W / m strip, 3000 K), guarantee of uniform light intensity up to 5 m length, extreme ease of installation with 3M double-sided adhesive tape and 36-month manufacturer's guarantee.*

Die LED-Lichtstreifen der Firma SKOFF stellen in jedem Haus und in jedem kommerziellen Raum eine ausgezeichnete Ergänzung der Beleuchtung dar. Die Vorteile unserer LED-Streifen sind vor allem hohe Qualität, Vielfalt der verfügbaren Streifen hinsichtlich der Stärke des emittierten Lichtes - von 420 lm / m (LED-Streifen 4,8 W / m, 6000 K) bis 1440 lm / m (LED-Streifen 21,6 W / m, 3000 K), das Licht, das auf 5m-Länge gleichmäßig verteilt ist, außergewöhnlich einfache Montage mittels eines doppelseitigen Klebebandes der Firma 3M und 36 Garantie des Herstellers*

LED páska SKOFF je výborné doplnění každého prostoru, jak domácího, tak komerčního. Její výhody jsou především vysoká kvalita, dostupné pásy s různým množstvím vyzařovaného světla - od 420 lm/m (páska 4,8 W / m 6000 K) do 1440 lm / m (páska 21,6 W / m 3000 K), záruka stejného svícení do 5 m délky, výjimečně snadná montáž pomocí dvoustranné lepicí pásky značky 3M a 36-měsíční záruka výrobce*.

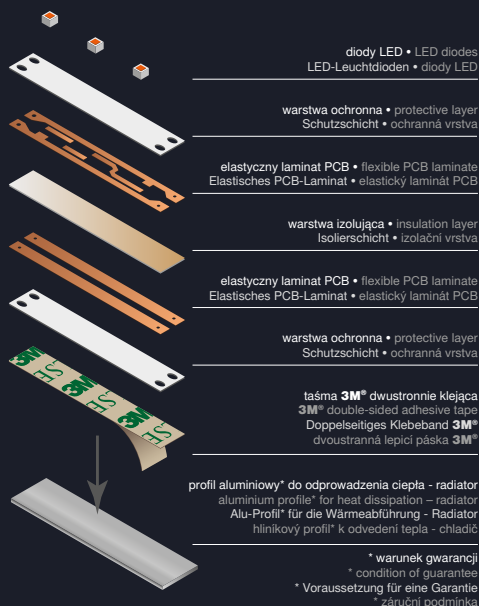

* - uwzględniana tylko przy poprawnym montażu bezpośrednio na radiatorze z profilu aluminiowego • applicable only with correct installation directly on aluminium profile radiator • gilt nur bei einer ordnungsgemäßen Montage direkt auf dem Radiator aus dem Alu-Profil • se zohledněním správné montáže přímo na chladiči z hliníkového profilu.

RAMKI I PÓŁKI MEBLOWE LED

LED FURNITURE SHELFs AND FRAMES

LED-LEUCHTREGAL UND RAHMEN

NÁBYTKOVÉ POLICE A RÁMKY LED



RAMKA S5

Do montażu na półkach szklanych o grubości 4-6 mm.

Korzyści:

- funkcja „3 w 1”: półka, oświetlenie, dekoracja;
- dekoracyjne podświetlenie półki wraz z wnętrzem szafki;
- zwiększenie nośności zwykłej półki szklanej;
- łatwy montaż na tradycyjnych podpórkach do półek szklanych;
- dostępność w trzech rozmiarach standardowych, bądź w formie dedykowanej do potrzeb klienta;
- 36 miesięcy gwarancji;
- więcej informacji na stronie www.skoff.pl.

For mounting on glass shelves 4-6 mm thick.

Advantages:

- „3 in 1” functionality: storage, lighting, decoration;
- decorative lighting of shelf and cabinet inside;
- reinforced capacity of an ordinary glass shelf;
- easy installation on conventional brackets for glass shelves;
- available in three standard sizes or custom-tailored, as required;
- 36-month guarantee;
- for more information go to www.skoff.pl.

PM SOLUM 2 I SOLUM 4

Alternatywa dla tradycyjnego oświetlenia w kuchni. Półka meblowa LED zastępuje dolną część wiszącej szafki kuchennej.

Korzyści:

- funkcja „3 w 1”: półka, oświetlenie, dekoracja;
- zapewnienie efektywnego oświetlenia blatu roboczego w kuchni oraz dekoracyjnego podświetlenia półki wraz z wnętrzem szafki;
- dostępność w różnych rozmiarach;
- solidna konstrukcja oparta o ramę aluminiową i szyby z hartowanego szkła o gr. 10 mm (SOLUM 2) lub dwóch tafli szklanych o gr. 4 mm każda (SOLUM 4);
- energooszczędność i łatwość montażu;
- 36 miesięcy gwarancji.

Alternative to traditional kitchen lighting. The LED light shelf replaces the bottom part of an upper kitchen cabinet.

Advantages:

- „3 in 1” functionality: storage, lighting, decoration;
- provides effective lighting of the kitchen worktop and decorative lighting of the shelf and cabinet inside;
- available in a range of sizes;
- solid structure based on an aluminium frame and tempered glass 10 mm thick (SOLUM 2) or two panes of glass 4 mm thick each (SOLUM 4);
- energy-saving and easy to mount;
- 36-month guarantee.

Die LED-Streifen können an den Glasfächern mit der Stärke 4-6 mm eingesetzt werden.

Vorteile:

- „3 in 1” - Funktion: Fach, Beleuchtung, Schmuckelement;
- Dekorative Beleuchtung des Faches und des Inneren des Schrankes;
- Vergrößerung der Tragfähigkeit des Glasfaches;
- Einfache Montage an den traditionellen Halterungen für die Glasfächer;
- In drei Standardgrößen bzw. in einer individuell gestalteten Form verfügbar;
- 36 Monate Garantie;
- Mehr Informationen sind der Internetseite www.skoff.pl zu entnehmen.

K montáži na skleněných policích s tloušťkou 4-6 mm.

Výhody:

- funkce „3 v 1”: police, osvětlení, dekorace;
- dekorální osvětlení police a vnitřní části skřínky;
- zvětšení nosnosti obyčejné skleněné police;
- snadná montáž na tradičních podpěrách k skleněným policím;
- dostupnost ve tři standardních velikostech nebo ve velikosti vytvořené speciálně na individuální zakázku;
- 36-měsíční záruka;
- více informací na internetové stránce [skoff.pl](http://www.skoff.pl).

Eine Alternative für die herkömmliche Küchenbeleuchtung. Das LED-Möbelfach kann den unteren Teil eines Küchenschrankes ersetzen.

Vorteile:

- „3 in 1” - Funktion: Fach, Beleuchtung, Schmuckelement;
- Effektive Beleuchtung der Arbeitsplatte in der Küche und dekorative indirekte Beleuchtung des Faches und des Inneren des Schrankes;
- In verschiedenen Größen lieferbar;
- Solide Konstruktion in Form eines Alu-Rahmens und der Scheibe aus gehärtetem Glas mit der Stärke 10 mm (SOLUM 2) bzw. in Form von 2 Glasscheiben mit der Stärke von jeweils 4 mm (SOLUM 4);
- Energiesparend, einfache Montage;
- 36 Monate Garantie.

Alternativa pro tradiční osvětlení v kuchyni. Nábytková police LED nahrazuje dolní část závěsné kuchyňské skřínky.

Výhody:

- funkce „3 v 1”: police, osvětlení, dekorace;
- tvoří efektivní osvětlení pracovního pultu v kuchyni a dekorální osvětlení police a vnitřní části skřínky;
- Dostupná ve tři velikostech;
- solidní konstrukce z tvrzeného skla s tloušťkou 10 mm (SOLUM 2) nebo dvou tabulí skla s tloušťkou 4 mm každá (SOLUM 4) na hliníkovém rámu;
- energetická úspora a snadná montáž;
- 36-měsíční záruka.

RAMKA typ S5

S5 Frame • Rahmen S5
Rámeček S5

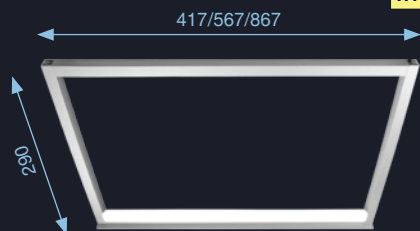
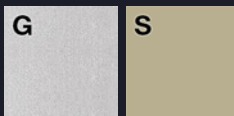

L = 417 mm H = 290 mm	3,6 W	227 lm 204 lm	6000–6500 K 3000–3500 K	12 V DC		
L = 567 mm H = 290 mm	5 W	345 lm 310 lm	6000–6500 K 3000–3500 K	IP20	Ra>80	
L = 867 mm H = 290 mm	7,9 W	545 lm 490 lm	6000–6500 K 3000–3500 K			

PM SOLUM 2

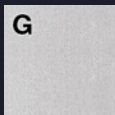

TYP	[mm]	[K]	[W]	[V]		IP20
S45	296x417	6000 K 3000 K	7	230 V AC		Ra>80
S60	296x567	6000 K 3000 K	11	230 V AC		
S90	296x867	6000 K 3000 K	18	230 V AC		

Produkt dostępny na specjalne zamówienie • Product available on special request • Das Produkt ist im Rahmen eines speziellen Bestellvorgangs erhältlich • Produkt dostupný na objednávku.

PM SOLUM 4

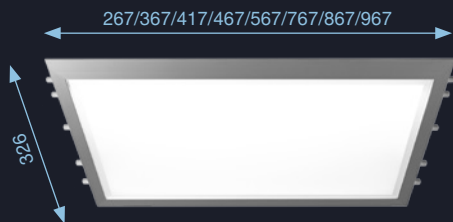
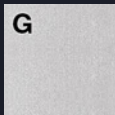

TYP	W [mm]	[K]	[W]	[V]		IP20
S4-030	267,8	3800 K	2,9	12 V DC		Ra>80
S4-040	367,8	3800 K	4,3	12 V DC		
S4-045	417,8	3800 K	5,0	12 V DC		
S4-050	467,8	3800 K	5,8	12 V DC		
S4-060	567,8	3800 K	7,2	12 V DC		
S4-080	767,8	3800 K	10,1	12 V DC		
S4-090	867,8	3800 K	11,5	12 V DC		
S4-100	967,8	3800 K	13	12 V DC		

OPRAWY MEBLOWE HALOGENOWE

FURNITURE HALOGEN FITTINGS

HALOGENMÖBELLEUCHTEN

HALOGENOVÁ NÁBYTKOVÝ
SVÍTIDLA



Źródło światła: żarówka halogenowa maks. 20 W

Light source: halogen bulb, max. 20 W

Lichtquelle: Halogen-Leuchtmittel max. 20 W

Zdroj světla: Halogenová žárovka max 20 W

Zalecany transformator •

Recommended transformer •

Empfohlener Transformator •

Doporučený transformátor:

ETH-40, ETH-70, ETH-105.

LHT2-1

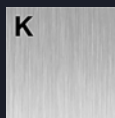
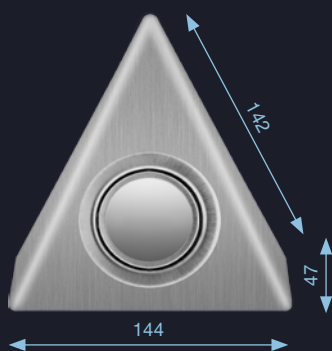

max 20 W	12 V AC	 60°
IP20	 min 0,3 m	

LHT2w-1

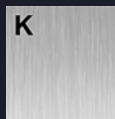

max 20 W	12 V AC	 60°
IP20	 min 0,3 m	



LHP2-1

LHT2-5

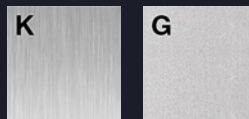
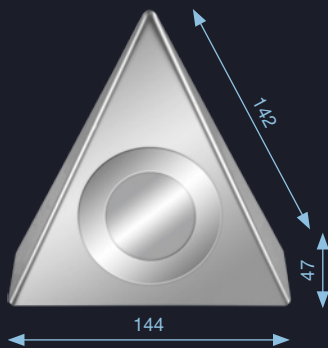

max 20 W	12 V AC	 60°
IP20	 min 0,3 m	

LHT2w-5



z wyłącznikiem
with switch
mit Schalter
s vypínačem

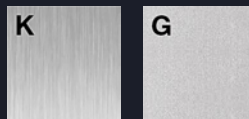

max 20 W	12 V AC	 60°
IP20	 min 0,3 m	

LHP2-1

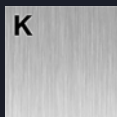

max 20 W	12 V AC	60°
IP20	min 0,3 m	

LHP2w-1

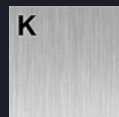

z wyłącznikiem
with switch
mit Schalter
s vypínačem

max 20 W	12 V AC	60°
IP20	min 0,3 m	

LHP2-5

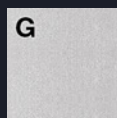
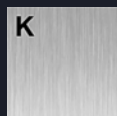
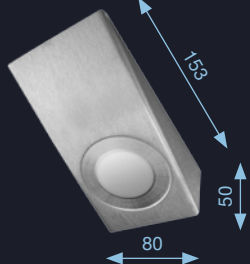

max 20 W	12 V AC	60°
IP20	min 0,3 m	

LHP2w-5

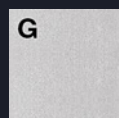
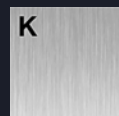

z wyłącznikiem
• with switch •
mit Schalter
s vypínačem

max 20 W	12 V AC	60°
IP20	min 0,3 m	

LHK2-1

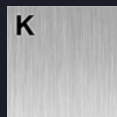
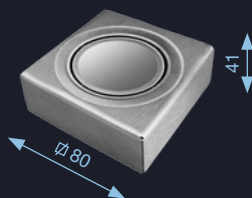

max 20 W	12 V AC	60°
IP20	min 0,3 m	

LHK2-5

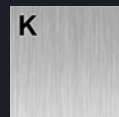
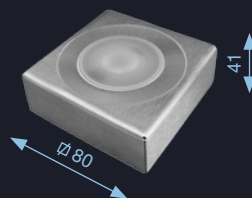

max 20 W	12 V AC	60°
IP20	min 0,3 m	

OMH1

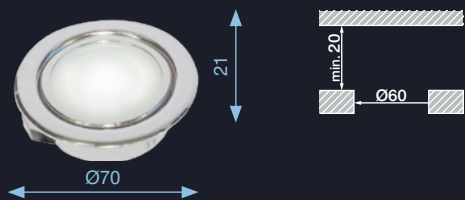

max 20 W	12 V AC	 60°
IP20	 min 0,3 m	

OMHd1

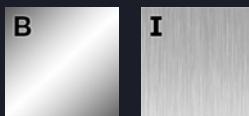

max 20 W	12 V AC	 60°
IP20	 min 0,3 m	

OMH5

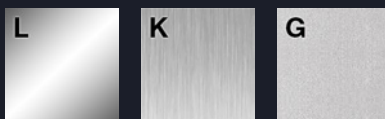
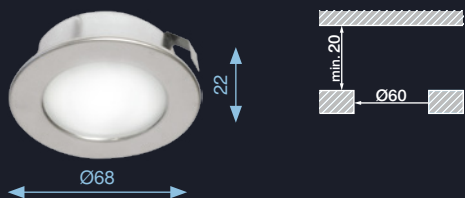

max 20 W	12 V AC	 60°
IP20	 min 0,3 m	

ZASILACZE NAPIĘCIOWE OPRAW LED 10 V

10 V CV POWER SUPPLIES
FOR LED LUMINAIRES

NETZTEILE FÜR LED-
LEUCHTEN 10 V

NAPĚŤOVÉ NAPAJEČE PRO
LED SVÍTIDLA 10 V

ZOL6



6 W	IN: 100-240 V AC 50 Hz	OUT: 10 V DC	
IP68			CE

ZOL7-10

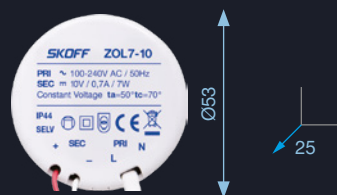

7 W	IN: 100-240 V AC 50 Hz	OUT: 10 V DC	
IP44			CE

ZOL16



16 W	IN: 100-240 V AC 50 Hz	OUT: 10 V DC	
IP68			CE

ZOL15-10

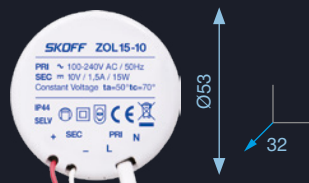

15 W	IN: 100-240 V AC 50 Hz	OUT: 10 V DC	
IP44			CE

ZOL19-10



19 W	IN: 100-240 V AC 50 Hz	OUT: 10 V DC	
IP68			CE

ZOLW1



1,2 W	IN: 100-240 V AC 50 - 60 Hz	OUT: 10 V DC	IP20

ZOLW6



6 W	IN: 100-240 V AC 50 - 60 Hz	OUT: 10 V DC	IP20

ZOLW16

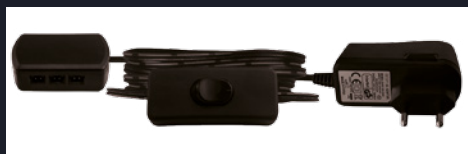

16 W	IN: 100-240 V AC 50 - 60 Hz	OUT: 10 V DC	IP20

ZASILACZE NAPIĘCIOWE OPRAW LED 12 V

12 V CV POWER SUPPLIES
FOR LED LUMINAIRES

NETZTEILE FÜR LED-
LEUCHTEN 12 V

NAPĚŤOVÉ NAPAJEČE PRO
LED SVÍTIDLA 12 V

ZOL19-12

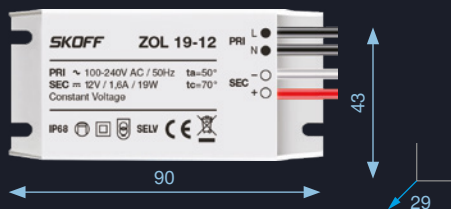

19 W	IN: 100-240 V AC 50 Hz	OUT: 12 V DC	IP68

ZOL7-12

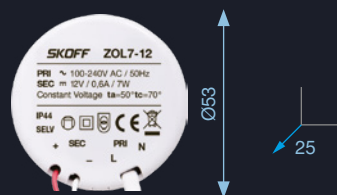

7 W	IN: 100-240 V AC 50 Hz	OUT: 12 V DC	
IP44			

ZOLW2



1,8 W	IN: 100-240 V AC 50 - 60 Hz	OUT: 12 V DC	IP20

ZOL15-12

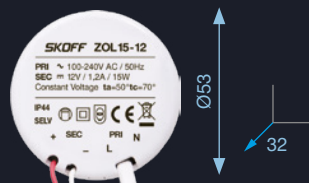

15 W	IN: 100-240 V AC 50 Hz	OUT: 12 V DC	
IP44			

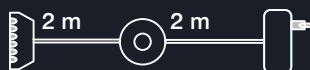

ZOLW7



7,2 W	IN: 100-240 V AC 50 - 60 Hz	OUT: 12 V DC	IP20
☐		CE	

ZOLW15



15 W	IN: 100-240 V AC 50-60 Hz	OUT: 12 V DC	IP20
☐		CE	

ZOLW20



20,4 W	IN: 100-240 V AC 50-60 Hz	OUT: 12 V DC	IP20
☐		CE	

ZASILACZE NAPIĘCIOWE OPRAW LED

POWER SUPPLIES FOR LED
LUMINAIRES

NETZTEILE FÜR LED-
LEUCHTEN

NAPĚŤOVÉ NAPAJEČE PRO
LED SVÍTIDLA

SKOFF SNP15-12VL



15 W	IN: 200-240 V AC 50 - 60 Hz	OUT: 12 V DC	
IP20			

SKOFF SNP15-12VF



15 W	IN: 200-240 V AC 50 - 60 Hz	OUT: 12 V DC	
IP20			

SKOFF SNP20-12VF

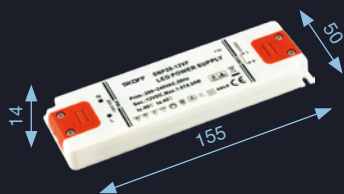

20 W	IN: 200-240 V AC 50 - 60 Hz	OUT: 12 V DC	
IP20			

SKOFF SNP30-12VF

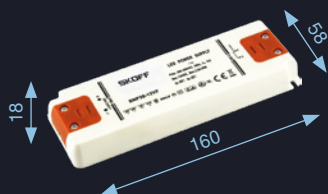

30 W	IN: 200-240 V AC 50 - 60 Hz	OUT: 12 V DC	
IP20			

ZASILACZE PRĄDOWE OPRAW LED

LED LUMINAIRE CURRENT
UNITS

KONSTANTSTROM NETZTEILE
FÜR LED-LEUCHTEN

PROUDOVÉ NAPAJEČE PRO
LED SVÍTIDLA

PZL16



16 W	IN: 230 V AC 50 Hz	OUT: 500 mA	
IP20			CE

PZL18



18 W	IN: 230 V AC 50 Hz	OUT: 350 mA DC	
IP20			CE

PZL25



25 W	IN: 230 V AC 50 Hz	OUT: 500 mA	
IP20			CE

TRANSFORMATORY ELEKTRONICZNE DO OPRAW HALOGENOWYCH

ELECTRONIC TRANSFORMERS FOR
HALOGEN LUMINAIRES

ELEKTRONISCHE
TRANSFORMATOREN FÜR
HALOGENLEUCHTEN

ELEKTRONICKÉ TRANSFORMÁTORY
PRO HALOGENOVÁ SVÍTLA

ETH-40

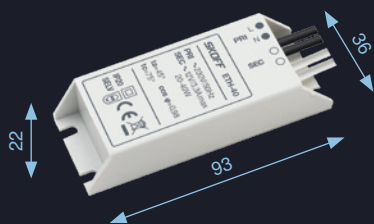

20-40 W	IN: 230 V AC	OUT: 12 V AC	IP20	
IP20				

ETH-70



20-70 W	IN: 230 V AC	OUT: 12 V AC		
IP20				

ETH-105



20-105 W	IN: 230 V AC	OUT: 12 V AC		
IP20				

AKCESORIA

ACCESSORIES

ZUBEHÖR

PŘÍSLUŠENSTVÍ

GNIAZDO GT1

Socket • Steckdose • Zásuvka

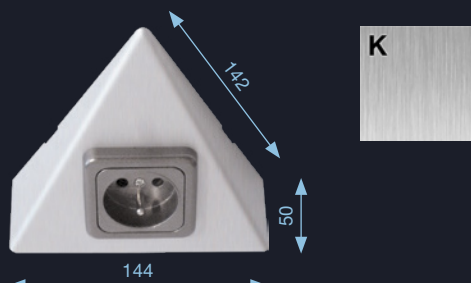

GNIAZDO GP1

Socket • Steckdose • Zásuvka

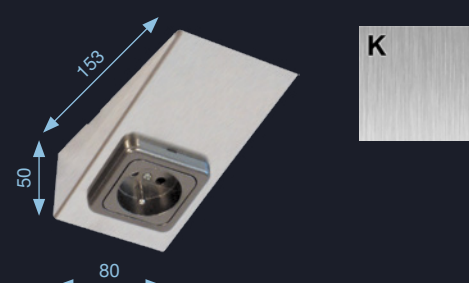

ŁĄCZNIK ŁT1

Switch • Schalter • Spínač

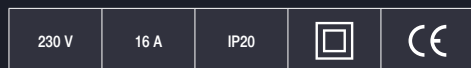
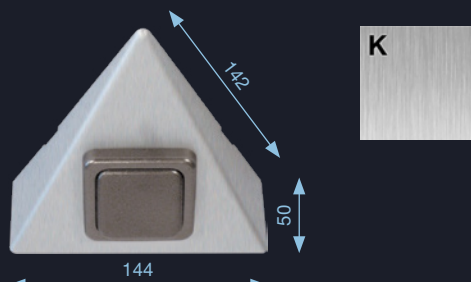

ŁĄCZNIK ŁP1

Switch • Schalter • Spínač

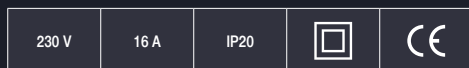
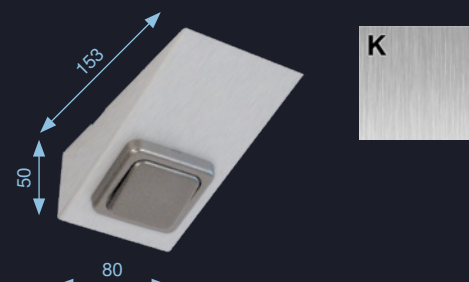

GNIAZDO Z WYŁĄCZNIKIEM GMW1P/C SCHUKO Z KLAPKĄ
 Socket with switch GMW1P/C SCHUKO with a lid • Steckdose mit Schalter
 GMW1P/C SCHUKO mit Klappdeckel • Zásuvka s vypínačem GMW1P/C
 SCHUKO S klapkou



GNIAZDO Z WYŁĄCZNIKIEM GMW1P/C Z BOLCEM Z KLAPKĄ
 Socket with switch GMW1P/C earthed with a lid • Steckdose mit Schalter
 GMW1P/C mit Erdungsstift mit klappdeckel • Zásuvka s vypínačem
 GMW1P/C z kolíkem a klapkou



ELEKTRONICZNY WYŁĄCZNIK DOTYKOWY EWD300
 Electronic touch-operated switch • Elektronischer Touch-Schalter •
 Elektronický dotykový vypínač



sensor przykręcony do metalowego
 elementu (gałka, obudowa lampy),
 odizolowany względem ziemi

300 W	IN: 230 V AC 50 Hz	IP20
		

WYŁĄCZNIK ZBLIŻENIOWY S01

Proximity switch • Bewegungsschalter • Bezkontaktní vypínač



Tryby pracy: czujnik zbliżeniowy/drzwiowy

Operating modes: proximity switch/door switch

Arbeitsmodus: Bewegungssensor/Türsensor

Režim: senzor přiblížení /dveří

Napięcie zasilania: Supply voltage: Spannung: Napájací napětí:	12 V	24 V	CE
Maksymalna moc opraw: Maximum luminaire power rating: Max. Leistung der Leuchten: Maximální výkon svítidel:	24 W	30 W	

WYŁĄCZNIKI OKRĄGŁE

KOŁYSKOWE R13

Circular rocker switches R13 •

Runde Wippschalter R13 • Vypínače

kulaté, kolébkové R13



WYŁĄCZNIK ŁAŃCUSZKOWY

Pull Chain Switch • Zugkette

Schalter • Retízkový vypínač



PRZEPUST ELASTYCZNY PE1

Flexible conduit • Elastische kabeldurchführung • Elastické priechodky

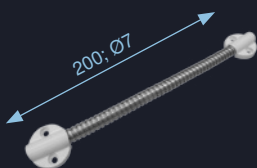

ZASTOSOWANIE: przeprowadzenie przewodu w drzwiczkach meblowych lub innym elemencie ruchomym.

APPLICATION: conduit run through furniture door or another movable component.

ANWENDUNG: durchführung der Leitung in der Möbeltür bzw. in einem anderen beweglichen Bauelement.

POUŽITIE: vedení kabelu uvnitř nábytkových dveří nebo jiného pohyblivého prvku.

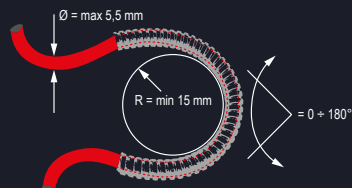

MATERIAŁY REKLAMOWE

ADVERTISING MATERIALS

WERBEMATERIAL

REKLAMNÍ MATERIÁLY

MINI STAND 2 z oświetleniem meblowym

Mini stand with furniture lighting • Mini Stand mit Möbelleuchten • Mini stand s nábytkovým osvětlením



TABLICA REKLAMOWA 2 z oświetleniem meblowym
 Advertising board with furniture lighting • Werbetafel mit Möbelleuchten •
 Reklamní tabule s nábytkovým osvětlením

850

OŚWIETLENIE
 MEBLOWE



SKOFF



PERLA CLASSIC LM7

CLARO LM1

PERLA LM1



CLIP LED KL1

CLIP LED KL2

CLIP LED KL3



PRZEPIŁST ELASTYCZNY PE1



LISTWA LED LL1

LISTWA LED LL2



PUNKTO OML5

PUNKTO OML6

PUNKTO OML6



RETANGO LLP7

EWD000

TRIANGO LL7

QUADRATO LLK7



ROTONDO OML2

ROTONDO OML3

COSMO OML7S

ROTONDO OML8

QUADRATO OML9



1000

SKOFF DESIGN

www.skoff.pl

MADE IN POLAND

* - asortyment produktów prezentowanych na tablicy może ulec zmianie • range of products presented on the table may be changed •
 Produktpalette in der Tabelle enthalten sind, können geändert werden • sortiment výrobků uvedených v tabulce může být změněn.

INDEKS • INDEX

OL Oprawy LED • LED fittings • LED-Leuchten • LED Světidla	2K1 Zestaw clipów 2KL1 • Clip Set 2KL1 • Clip Set 2KL1 • Clip Set 2KL1	L Lustro (INOX) • Mirror (INOX) • Spiegel (INOX) • Zrcadlo (INOX)	W Zimny biały • Cool white • Kaltweiß • Studená bílá H Ciepły biały • Warm white • Warmweiß • Teplá bílá B Niebieski • Blue • Blau • Modrá
	KL1 Clip LED KL1	L Lustro (INOX) • Mirror (INOX) • Spiegel (INOX) • Zrcadlo (INOX)	W Zimny biały • Cool white • Kaltweiß • Studená bílá H Ciepły biały • Warm white • Warmweiß • Teplá bílá B Niebieski • Blue • Blau • Modrá
	KL2 Clip LED KL2	G Aluminium • Aluminium • Aluminium • Hliník T Transparentny • Transparent • Transparent • Transparentní	W Zimny biały • Cool white • Kaltweiß • Studená bílá H Ciepły biały • Warm white • Warmweiß • Teplá bílá
	KL3 Clip LED KL3	T Transparentny • Transparent • Transparent • Transparentní	W Zimny biały • Cool white • Kaltweiß • Studená bílá H Ciepły biały • Warm white • Warmweiß • Teplá bílá
	PK5 Punktó 5	G Aluminium • Aluminium • Aluminium • Hliník	W Zimny biały • Cool white • Kaltweiß • Studená bílá H Ciepły biały • Warm white • Warmweiß • Teplá bílá
	P5D Punktó 5 z dystansem	G Aluminium • Aluminium • Aluminium • Hliník	W Zimny biały • Cool white • Kaltweiß • Studená bílá H Ciepły biały • Warm white • Warmweiß • Teplá bílá
	PK6 Punktó 6	G Aluminium • Aluminium • Aluminium • Hliník	W Zimny biały • Cool white • Kaltweiß • Studená bílá H Ciepły biały • Warm white • Warmweiß • Teplá bílá
	RO2 Rotondo 2	B Chrom • Chrome • Chrom • Chrom	W Zimny biały • Cool white • Kaltweiß • Studená bílá H Ciepły biały • Warm white • Warmweiß • Teplá bílá
	R21 Rotondo 2-1	I Nikiel szlif • Ground nickel • Nickel geschliffen • Broušený nikiel	W Zimny biały • Cool white • Kaltweiß • Studená bílá H Ciepły biały • Warm white • Warmweiß • Teplá bílá
	RO3 Rotondo 3	G Aluminium • Aluminium • Aluminium • Hliník	W Zimny biały • Cool white • Kaltweiß • Studená bílá H Ciepły biały • Warm white • Warmweiß • Teplá bílá
R31 Rotondo 3-1	G Aluminium • Aluminium • Aluminium • Hliník	W Zimny biały • Cool white • Kaltweiß • Studená bílá H Ciepły biały • Warm white • Warmweiß • Teplá bílá	
RO8 Rotondo 8	G Aluminium • Aluminium • Aluminium • Hliník	W Zimny biały • Cool white • Kaltweiß • Studená bílá H Ciepły biały • Warm white • Warmweiß • Teplá bílá	
R81 Rotondo 8-1	G Aluminium • Aluminium • Aluminium • Hliník	W Zimny biały • Cool white • Kaltweiß • Studená bílá H Ciepły biały • Warm white • Warmweiß • Teplá bílá	
QU9 Quadrato 9	G Aluminium • Aluminium • Aluminium • Hliník	W Zimny biały • Cool white • Kaltweiß • Studená bílá H Ciepły biały • Warm white • Warmweiß • Teplá bílá	
Q91 Quadrato 9-1	G Aluminium • Aluminium • Aluminium • Hliník	W Zimny biały • Cool white • Kaltweiß • Studená bílá H Ciepły biały • Warm white • Warmweiß • Teplá bílá	
G7P Cosmo OML7p	I Nikiel szlif • Ground nickel • Nickel geschliffen • Broušený nikiel D Czarny • Black • Schwarz • Černý G Aluminium • Aluminium • Aluminium • Hliník	W Zimny biały • Cool white • Kaltweiß • Studená bílá H Ciepły biały • Warm white • Warmweiß • Teplá bílá	
LL Lampy LED • LED lamps • LED-Lampen • Lampy LED	TR2 Triango LLT 2	K Szlif • Stainless steel • Edelstahl geschliffen • Brus	W Zimny biały • Cool white • Kaltweiß • Studená bílá H Ciepły biały • Warm white • Warmweiß • Teplá bílá
	TW2 Triango LLT2w z wyl.	G Aluminium • Aluminium • Aluminium • Hliník	W Zimny biały • Cool white • Kaltweiß • Studená bílá H Ciepły biały • Warm white • Warmweiß • Teplá bílá
	RE2 Retango LLP2		
	RW2 Retango LLP2w z wyl.		
	TR7 Triango LLT7		
	TW7 Triango LLT7w z wyl.		
	RE7 Retango LLP7		
	RW7 Retango LLP7w z wyl.		
	QU7 Quadrato LLK7	K Szlif • Stainless steel • Edelstahl geschliffen • Brus	W Zimny biały • Cool white • Kaltweiß • Studená bílá H Ciepły biały • Warm white • Warmweiß • Teplá bílá
	C01 Claro LN1	0 Standard • Standard • Standard • Standard	W Zimny biały • Cool white • Kaltweiß • Studená bílá H Ciepły biały • Warm white • Warmweiß • Teplá bílá N Neutralny • Neutral • Neutral • Neutrální
P11 Perla LN11	0 Standard • Standard • Standard • Standard	W Zimny biały • Cool white • Kaltweiß • Studená bílá H Ciepły biały • Warm white • Warmweiß • Teplá bílá	
P07 Perla Classic LN7	0 Standard • Standard • Standard • Standard	W Zimny biały • Cool white • Kaltweiß • Studená bílá H Ciepły biały • Warm white • Warmweiß • Teplá bílá	
P08 Perla Classic Max LN8	3 300 mm 5 500 mm	W Zimny biały • Cool white • Kaltweiß • Studená bílá H Ciepły biały • Warm white • Warmweiß • Teplá bílá	
N09 Natali LN9	2 289 mm 4 454 mm 6 624 mm	W Zimny biały • Cool white • Kaltweiß • Studená bílá H Ciepły biały • Warm white • Warmweiß • Teplá bílá	
N10 Natali Classic LN10	3 325 mm 4 490 mm 6 660 mm	W Zimny biały • Cool white • Kaltweiß • Studená bílá H Ciepły biały • Warm white • Warmweiß • Teplá bílá	
S54 Ramka S5 417x290 mm	G Aluminium • Aluminium • Aluminium • Hliník	W Zimny biały • Cool white • Kaltweiß • Studená bílá H Ciepły biały • Warm white • Warmweiß • Teplá bílá	
S56 Ramka S5 567x290 mm	S Szampański • champagne • Champagne • šampaňská	H Ciepły biały • Warm white • Warmweiß • Teplá bílá	
S59 Ramka S5 867x290 mm	S Szampański • champagne • Champagne • šampaňská	H Ciepły biały • Warm white • Warmweiß • Teplá bílá	
LI Listwy LED • LED profiles • LED-Leisten • Lišty LED	LL1 Leo LL1	4 410 mm	W Zimny biały • Cool white • Kaltweiß • Studená bílá H Ciepły biały • Warm white • Warmweiß • Teplá bílá
	LL2 Leo LL2	6 560 mm 9 860 mm	H Ciepły biały • Warm white • Warmweiß • Teplá bílá
	LL3 Roxy LL3	2 250 mm 5 500 mm 9 900 mm	W Zimny biały • Cool white • Kaltweiß • Studená bílá H Ciepły biały • Warm white • Warmweiß • Teplá bílá N Neutralny • Neutral • Neutral • Neutrální
	LL5 Leo LL5	3 375 mm	H Ciepły biały • Warm white • Warmweiß • Teplá bílá
	L64 Leo LL6 417 mm	G Aluminium • Aluminium • Aluminium • Hliník	W Zimny biały • Cool white • Kaltweiß • Studená bílá H Ciepły biały • Warm white • Warmweiß • Teplá bílá
	L66 Leo LL6 567 mm	S Szampański • champagne • Champagne • šampaňská	H Ciepły biały • Warm white • Warmweiß • Teplá bílá
	L66 Leo LL6 867 mm	S Szampański • champagne • Champagne • šampaňská	H Ciepły biały • Warm white • Warmweiß • Teplá bílá
	71A Ivo LL7 0,24 W 100 mm	G Aluminium • Aluminium • Aluminium • Hliník	W Zimny biały • Cool white • Kaltweiß • Studená bílá H Ciepły biały • Warm white • Warmweiß • Teplá bílá
	71B Ivo LL7 0,72 W 100 mm	G Aluminium • Aluminium • Aluminium • Hliník	H Ciepły biały • Warm white • Warmweiß • Teplá bílá
	72A Ivo LL7 0,24 W 200 mm	G Aluminium • Aluminium • Aluminium • Hliník	N Neutralny • Neutral • Neutral • Neutrální
72B Ivo LL7 0,72 W 200 mm	G Aluminium • Aluminium • Aluminium • Hliník	N Neutralny • Neutral • Neutral • Neutrální	
TL1 Pablo TL1	4 410 mm 6 560 mm 9 860 mm	W Zimny biały • Cool white • Kaltweiß • Studená bílá H Ciepły biały • Warm white • Warmweiß • Teplá bílá N Neutralny • Neutral • Neutral • Neutrální	
TL4 Pablo TL4	4 410 mm 6 560 mm 9 860 mm	W Zimny biały • Cool white • Kaltweiß • Studená bílá H Ciepły biały • Warm white • Warmweiß • Teplá bílá N Neutralny • Neutral • Neutral • Neutrální	
PM Półki meblowe • Furniture shelf • Glasboden • Nábytková police	S45 Solum2 do szafki 450 mm S60 Solum2 do szafki 600 mm S90 Solum2 do szafki 900 mm	A Grubość płyty 16 mm • Plate thickness 16 mm • Blechdicke 16 mm • Tloušťka plechu 16 mm	W Zimny biały • Cool white • Kaltweiß • Studená bílá H Ciepły biały • Warm white • Warmweiß • Teplá bílá
PM Półki meblowe • Furniture shelf • Glasboden • Nábytková police	N30 Solum4 do szafki 300 mm N40 Solum4 do szafki 400 mm N45 Solum4 do szafki 450 mm N50 Solum4 do szafki 500 mm	A Grubość płyty 16 mm • Plate thickness 16 mm • Blechdicke 16 mm • Tloušťka plechu 16 mm	N Neutralny • Neutral • Neutral • Neutrální

PM Półki meblowe • Furniture shelf • Glasboden • Nábytková police	N60	Solum4 do szafki 600 mm	A Grubość płyty 16 mm • Plate thickness 16 mm • Blechdicke 16 mm • Tloušťka plechu 16 mm	N Neutralny • Neutral • Neutral • Neutrální			
	N80	Solum4 do szafki 800 mm					
	N90	Solum4 do szafki 900 mm					
	NX0	Solum4 do szafki 1000 mm					
TL Taśmy LED • LED strip • LED-Leiste • pásek LED	048	Taśma LED 4,8 W	A Moduł LED 50 x 8 mm • LED module 50 x 8 mm • LED Modul 50 x 8 mm • Modul LED 50 x 8 mm B Moduł LED 25 x 8 mm • LED module 25 x 8 mm • LED Modul 25 x 8 mm • Modul LED 25 x 8 mm C Moduł LED 33 x 12 mm • LED module 33 x 12 mm • LED Modul 22 x 12 mm • Modul LED 33 x 12 mm	W Zimny biały • Cool white • Kaltweiß • Studená bílá H Ciepły biały • Warm white • Warmweiß • Teplá bílá N Neutralny • Neutral • Neutral • Neutrální			
	096	Taśma LED 9,6 W					
	144	Taśma LED 14,4 W					
	216	Taśma LED 21,6 W					
LH Lampy halogenowe • Halogen lamps • Halogenleuchten • Halogenové lampy	T21	LHT2-1	K Szlif • Stainless steel • Edelstahl geschliffen • Brus G Aluminium • Aluminium • Aluminium • Hliník L Lustro • Mirror • Spiegel • Zrcadlo G Aluminium • Aluminium • Aluminium • Hliník	S Standard • Standard • Standard • Standard W Wylącznik • Switch • Schalter • Vypínač S Standard • Standard • Standard • Standard W Wylącznik • Switch • Schalter • Vypínač W Wylącznik • Switch • Schalter • Vypínač S Standard • Standard • Standard • Standard S Standard • Standard • Standard • Standard W Wylącznik • Switch • Schalter • Vypínač W Wylącznik • Switch • Schalter • Vypínač			
	P21	LHP2-1					
	T25	LHT2-5					
	P25	LHP2-5					
	T25	LHT2w-5					
	P25	LHP2w-5					
	K21	LHK2-1					
	K25	LHK2-5					
	OH Oprawy Halogenowe • Halogen fittings • Halogenleuchten • Halogenová svítidla	HA1			OMH1	B Chrom • Chrome • Chrom • Chrom I Nikiel szlif • Ground nickel • Nickel geschliffen • Broušený nikiel F Mosiądz starzony • Aged brass • Altmessing • Patinovaná mosaz	W Biały • White • Weiß • Bílá W Biały • White • Weiß • Bílá W Biały • White • Weiß • Bílá
		HD1			OMHd1		
HA5		OMH5					
GMW		Gniazdo meblowe z wtycznikiem • Furniture Socket with switch • Steckdose mit Schalter • Zásuvka s vypínačem					
AM Akcesoria meblowe • Furniture accessories • Möbelzubehör • Nábytkové doplňky	GP1	Gniazdo prostokątne • Rectangular Socket • Steckdose rechteckig • Obdĺžniková zásuvka	K Szlif • Stainless steel • Edelstahl geschliffen • Brus	B Bolec z klapką • Earthed with a lid • Erdungsstift mit Klappdeckel • Z kolíkem a klapkou D Schuko z klapką • Schuko with a lid • Schuko mit Klappdeckel • Schuko s klapkou A Bolec • Earthed • Erdungsstift • Z kolíkem			
	GT1	Gniazdo trójkątne • Triangular Furniture Socket • Steckdose dreieckig • Trojúhelníková zásuvka					
	LP1	Łącznik prostokątny • Rectangular switch • Schalter rechteckig • Obdĺžnikový spínač					
	LT1	Łącznik trójkątny • Triangular switch • Schalter dreieckig • Trojúhelníkový spínač					
	EL Elektronika • Electronics • Elektronik • Elektronika	040			40 W	H Zasilacz halogenowy • Power supply for halogen fittings • Netzteil für Halogen • Halogenový napájecí zdroj W Wylącznik dotykowy • Touch-operated switch • Touch-Schalter • Dotykový vypínač C 10 V DC	N Napieciowy • Voltage • Spannung • Napětový N Napieciowy • Voltage • Spannung • Napětový 1 Typ 1 • Type 1 • Typ 1 • Typ 1
070	70 W						
105	105 W						
300	300 W						
ZL Zasilacze LED • LED power supply • LED Netzteile • Napajáče LED	006	6 W	A 10 V DC wtyczkowy • 10 V DC plug • 10 V DC Einsteck • 10 V DC zástrčka D 12 V DC B 12 V DC wtyczkowy • 12 V DC plug • 12 V DC Einsteck • 12 V DC zástrčka E Prądowy 350 mA • Current 350 mA • Konstantstrom 350 mA • Proudové 350 mA F Prądowy 500 mA • Current 500 mA • Konstantstrom 500 mA • Proudové 500 mA 2 20 cm	W Biały • White • Weiß • Bílý R Brązowy • Brown • Braun • Hnědý B Czarny • Black • Schwarz • Černý W Biały • White • Weiß • Bílý R Brązowy • Brown • Braun • Hnědý B Czarny • Black • Schwarz • Černý			
	007	7 W					
	015	15 W					
	016	16 W					
	019	19 W					
	001	1 W					
	006	6 W					
	016	16 W					
	007	7 W					
	015	15 W					
	019	19 W					
	002	2 W					
	007	7 W					
	015	15 W					
020	20 W						
018	18 W						
016	16 W						
025	25 W						
AO Akcesoria oświetleniowe • Lighting Accessories • Beleuchtung Zubehör • Osvětlovací doplňky	PEL	Przepust elastyczny • Flexible conduit • Elastische Kabeldurchführung • Elastické průchodky	K Kotyiskowe • Rocker • Wipp • Kolébkové Z Zbliżeniowy • Touch-operated • Touch-schalter • Bezkontaktní vypínač	W Biały • White • Weiß • Bílý R Brązowy • Brown • Braun • Hnědý B Czarny • Black • Schwarz • Černý			
	WYL	Wylączniki • Switches • Schalter • Vypínače					
	WYL	Wylączniki • Switches • Schalter • Vypínače					

Dystrybutor • Distributor



SKOFF



43-500 Czechowice-Dziedzice
ul. Legionów 243 D
POLAND
tel./fax +48 (32) 215 28 93
email: info@skoff.pl

www.skoff.pl

SKOFF DESIGN