



pizzato elettrica

Position switches
Safety switches
Microswitches
Foot switches



General Catalog 2002

Company profile

The company Pizzato Elettrica S.r.l. was established in the year 1984 at Marostica (VI) - Italy and is now one of the most important Italian companies manufacturing position and limit switches, microswitches and safety switches. A dynamic company focused to the market development, since its beginning it has experienced a constant growth, gaining an important share of the Italian and European market. Since all the products are designed and assembled in their own plants, the company is able to satisfy any time the specific requirements of their clients offering a range of more than 5000 items in the catalog.



The production of the Pizzato Elettrica is developed in three plants which cover a production area of more than 5000 m². and employ about 90 people among employees, operators and technicians.



The company owns many national and European patents and focuses on maintaining high quality standards for its products. Quality certified by the marks IMQ, UL, CSA standing in the most of its products. Pizzato Elettrica has earned the UNI EN ISO 9002 certification, which guarantees the production-quality.

↘ 5000 Items in the catalog

↘ 3 production-plants with 5200 m² of covered surface

↘ Certification UNI EN ISO 9002

↘ Quality marks IMQ, UL, CSA

Twenty-years-experience



1980



1988



1995



1999



2001

How to read a page of our catalog :

Pollution degree according to IEC 947-1
See details on page 235

Protection degree of the housings according to IEC 529
See table on page 236

Position switches series FD



Technical data

Housing

Made of metal, coated with baked epoxy powder.
One conduit entry PG 13.5 or M20x1.5

Protection degree:

IP66

General data

Ambient temperature: from -25°C to +80°C
Max operating frequency: 3600 operations/hour
Mechanical endurance: from 10 to 20 millions of operations

Electrical data

Thermal current (Ith): 10A
Rated insulation voltage (Ui): 500 VAC 600 VDC
400 VAC for B20 - B21 - B22
fuse 10A 500V type aM
Pollution degree: 3

Utilization categories

Alternate current: AC15 (50...60Hz)		
Ue(V)	250	400
Ic(A)	6	1
Direct current: DC13		
Ue(V)	24	125
Ic(A)	6	1.1

Conforms to the standards:

IEC 947-5-1, IEC 337-1, EN 60947-5-1, CEI EN 60947-5-1, CEI 17-45, EN 50041, CEI 17-31, IEC 204-1, EN 60204-1, CEI 44-5, EN 1088, EN 292, IEC 529, EN 60529, CEI 70-1, NCF 63-140, VDE 0660-200, VDE 0113, CENELEC EN 50013.

Approvals type:

IEC 947-5-1, UL 508, CSA C22-2 nr.14.

Complying with the requirements requested by:

Low Voltage Directive 73/23/EEC and subsequent modifications and completions, Machinery Directive 98/37/EEC, Electromagnetic Compatibility 89/336/EEC and subsequent modifications and completions.

Positive contact opening complying with the standards:

IEC 947-5-1, EN 60947-5-1, CEI EN 60947-5-1, VDE 0660-206.

List of standards and directives
See details on page 233

Markings and quality marks:

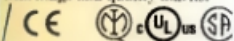

Approval type IMQ: EG605
Approval type UL: E131787
Approval type CSA: LR 93682-1

Markings and quality marks See details on page 233

Installation for safety applications :

Use only switches with the symbol \oplus on their sides. Safety circuit must always be connected with the NC contacts (normally closed contacts: 11-12, 21-22 or 31-32) as stated in the standard CEI EN 60947-5-1, encl. K, par. 2. The switch must be actuated with the minimum positive opening travel shown in the travels diagrams on page 12. The switch must be actuated with the minimum positive opening force, shown in brackets, underneath each article, near the value of the min. force. For a correct installation of these articles see examples on page 231.

Application requirements for the installation
See references to the standards on page 141 and installation examples on page 231

Data type approved by IMQ

- Rated insulation voltage (Ui) 500 VAC
400 VAC (for B20, B21, B22, B33, B34)
- Thermal current (Ith) 10A
- Protection against short circuits fuse 10A 500V type aM
- Protection degree of the housing IP66
- MV terminals (screw clamps)
- Pollution degree 3
- Utilization category AC15
- Operation voltage (Ue) 400 VAC (50 Hz)
- Operation current (Ic) 3A
- Forms of the contact element Za, Zb, Za+Zb, Y+Y, X+X, Y+X+X, Y+Y+Y, Y+X+X
- Positive opening of contacts on B5, B6, B7, B9, B11, B14, B16, B20, B21, B22, B33, B34
- Conforms to the standards: EN60947-1, EN 60947-1 A11, EN 60947-5-1 and fundamental requirements of the Low Voltage Directive 73/23/EEC and 93/68 EEC.

Please contact our technical service for the list of our type approved products

Data type approved by UL

- Utilization categories Q300 (69VA, 125-250 VDC)
A600 (720VA, 120-600 VDC)
- Data of the housing Type 1, 4X
(indoor use only), 12, 13
- Conforms to the standard: UL 508

Please contact our technical service for the list of our type approved products

Data type approved by CSA

- Utilization categories Q300 (69VA, 125-250 VDC)
A600 (720VA, 120-600 VDC)
- Data of the housing Type 1, 4X
(indoor use only), 12, 13
- Conforms to the standard: CSA C22-2 nr.14

Please contact our technical service for the list of our type approved products

Data type approved by UL
See details on pages 233-236

Data type approved by CSA
See details on pages 233-236

Series and housing material

Classification of the contact blocks according to IEC 947-5-1
See details on page 235

Article codes on green background:
Articles managed on the store house

Series FD metal housing

Denomination of the contact block

Article code
See details on page 13

B5	Zs	stop action	FD 501	INO-INC	FD 502	INO-INC	FD 504	INO-INC
B6	Zs	slow action	FD 601	INO-INC	FD 602	INO-INC	FD 604	INO-INC
B7	Zs	slow action	FD 701	INO-INC Overlapped Contacts	FD 702	INO-INC Overlapped Contacts	FD 704	INO-INC Overlapped Contacts
B9	V-V	slow action	FD 901	INC	FD 902	INC	FD 904	INC
B10	S-V	slow action	FD 1001	2NO	FD 1002	2NO	FD 1004	2NO
B11	V-V	stop action	FD 1101	INC	FD 1102	INC	FD 1104	INC
B14	V-V	slow action	FD 1401	INC Stuffed Contacts	FD 1402	INC Stuffed Contacts	FD 1404	INC Stuffed Contacts
B15	S-V	slow action	FD 1501	2NO Stuffed Contacts	FD 1502	2NO Stuffed Contacts	FD 1504	2NO Stuffed Contacts
B20	V-V-S	slow action	FD 2001	INC-1NO	FD 2002	INC-1NO	FD 2004	INC-1NO
B21	V-V-V	slow action	FD 2101	INC	FD 2102	INC	FD 2104	INC
B22	V-V-S	slow action	FD 2201	INC-2NO	FD 2202	INC-2NO	FD 2204	INC-2NO
B2	Zs/Zs	stop action	FD 201	INO-INC-INO-INC	FD 202	INO-INC-INO-INC	FD 204	INO-INC-INO-INC
Max. speed			page 13 - type 4		page 13 - type 3		0.5 m/s	
Min. force			8 N (20 N)		6 N (20 N)		17 Nmin	
Travel diagrams			page 12 - group 1		page 12 - group 2		page 12 - group 1	

Max. actuation speed
See details on page 13

Series FD metal housing

B5	Zs	stop action	FD 505	INO-INC	FD 508	INO-INC	FD 510	INO-INC
B6	Zs	slow action	FD 605	INO-INC	FD 608	INO-INC	FD 610	INO-INC
B7	Zs	slow action	FD 705	INO-INC Overlapped Contacts	FD 708	INO-INC Overlapped Contacts	FD 710	INO-INC Overlapped Contacts
B9	V-V	slow action	FD 905	INC	FD 908	INC	FD 910	INC
B10	S-V	slow action	FD 1005	2NO	FD 1008	2NO	FD 1010	2NO
B11	V-V	stop action	FD 1105	INC	FD 1108	INC	FD 1110	INC
B14	V-V	slow action	FD 1405	INC Stuffed Contacts	FD 1408	INC Stuffed Contacts	FD 1410	INC Stuffed Contacts
B15	S-V	slow action	FD 1505	2NO Stuffed Contacts	FD 1508	2NO Stuffed Contacts	FD 1510	2NO Stuffed Contacts
B20	V-V-S	slow action	FD 2005	INC-1NO	FD 2008	INC-1NO	FD 2010	INC-1NO
B21	V-V-V	slow action	FD 2105	INC	FD 2108	INC	FD 2110	INC
B22	V-V-S	slow action	FD 2205	INC-2NO	FD 2208	INC-2NO	FD 2210	INC-2NO
B2	Zs/Zs	stop action	FD 205	INO-INC-INO-INC	FD 208	INO-INC-INO-INC	FD 210	INO-INC-INO-INC
Max. speed			page 13 - type 3		page 13 - type 4		page 13 - type 4	
Min. force			6 N (20 N)		8 N (20 N)		11 N (21 N)	
Travel diagrams			page 12 - group 2		page 12 - group 1		page 12 - group 1	

Contacts table

Min. actuating force
In brackets the positive opening force.

Items with code on the green background are available in stock.

Type of operation
See details on page 234

With positive opening
See details on page 141

Contacts features
See details on page 12

General data of the heavy series **FD-FP-FL-FC**

Orientable heads

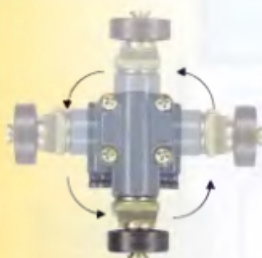

By taking out the four fastening screws, it is possible to rotate the head in 90° increments.

Adjustable levers

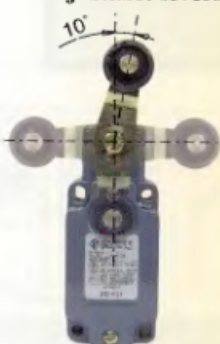

In the switches with revolving lever it is possible to adjust the lever with 10° increments for all the 360°. The positive movement transmission is always guaranteed thanks to the particular geometrical coupling shape between the lever and the revolving shaft (photo below), as the German standard BG-GS-ET-15 prescribes for safety applications.



Unidirectional heads

In the switches with revolving lever, you can select the directional operation by removing the four screws of the head and revolving the internal piston.

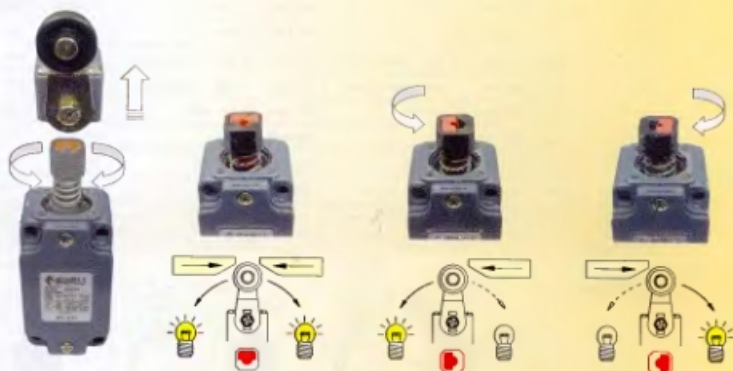

Screws driving torques

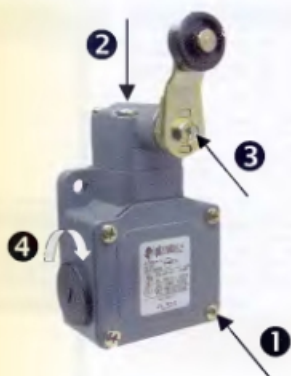

Tighten all the fastening screws (cover **1**, head **2** and lever **3**) with a driving torques **0,8 ... 1,2 Nm**. Tighten the protection plugs **4** with a driving torques **1,2 ... 2,0 Nm**.

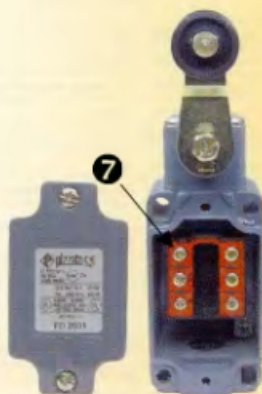

Tighten the fastening screws **7** of the contact blocks with a driving torques **0,6 ... 0,8 Nm**.

Contact block with snap action: B2 - B3 - B5 - B11

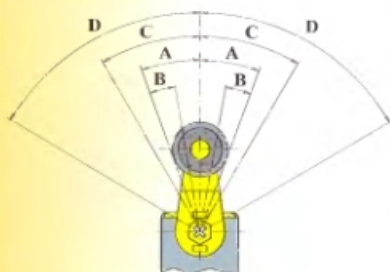

A	NC opening and NO closing
B	Differential travel
C	Positive opening travel
D	Max. travel

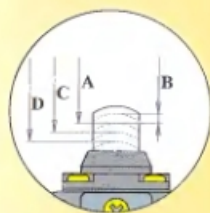
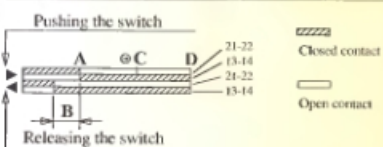

Contact block with slow action: B6 - B7 - B9 - B10 - B14 - B15 - B20 - B21 - B22

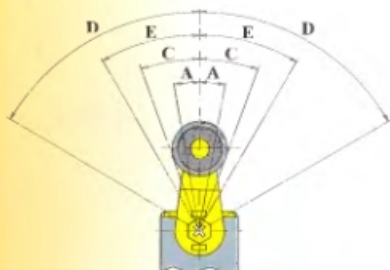

A	NC opening
C	Positive opening travel
E	NO closing
D	Max. travel

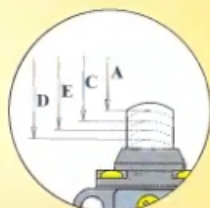
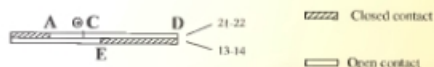

Travels diagrams of the series FD - FP - FL (All measures in the diagrams are in mm or degrees).

Contact blocks	Heads groups	Group 1	Group 2	Group 3	Group 4	Group 5	Group 6
B5 1NO+1NC	13 21 14 22						
B6 1NO+1NC	13 21 14 22						
B7 1NO+1NC	13 21 14 22						
B9 2NC	11 21 12 22						
B10 2NO	13 23 14 24						
B11 2NC	11 21 12 22						
B14 2NC	11 21 12 22						
B15 2NO	13 23 14 24						
B16 2NC	11 21 12 22						
B20 2NC+1NO	11 21 33 12 22 34						
B21 3NC	11 21 31 12 22 32						
B22 1NC+2NO	11 23 33 12 24 34						
B2 1NO-1NC=1NO-1NC	13 21 43 31 14 22 44 32						

General data of the heavy series **FD-FP-FL-FC**

Maximum actuation speed

Type 1: lever with roller

φ	V_{max} (m/s)
15°	2,5
30°	1,5
45°	1
60°	0,75

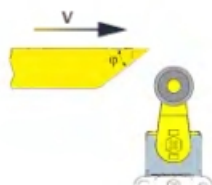

Type 2: plunger with roller.

φ	V_{max} (m/s)
15°	1
30°	0,5

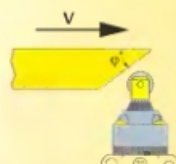

Type 3: lever with roller :

φ	V_{max} (m/s)
15°	1,5
30°	1

1) with side action

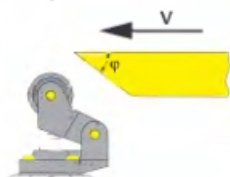

2) with vertical action



Type 4: plunger.

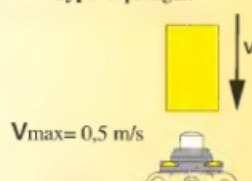

Maximum cross section of the conductors (flexible lead wire) in the contact blocks

Contact blocks B2, B3, B20, B21, B22, B33, B34	Contact blocks B5, B6, B7, B9, B10, B11, B14, B15, B16
2 x 1,5 mm ² (2 x AWG 16)	2 x 2,5 mm ² (2 x AWG 14)

Code of the article: how to read the code

Please contact our sales office, since no all combinations are available.

FD 501 - M2

Suffixes

- 1 with metal roller
- 2 with plastic Ø 35 roller
- M1 threaded housing M16x1,5
- M2 threaded housing M20x1,5

Kind of housing

FD metal housing, complying with EN 50041

FL metal housing

FP housing of polymer thermoplastic resin, complying with EN 50041

FC metal housing

Kind of contact block

B5 INC+INO snap action

B6 INC+INO slow action

B7 INC+INO slow action

.....

13 different contact blocks quoted with the letter B can be used

Kind of actuator

01 with plunger

02 with lever with roller

05 with roller lever

.....

31 different heads are present in the position switches

ACCESSORIES

Light indicator

A light indicator is used in order to visualize a change of state of the electric contacts inside the switch. It can be installed only in the series FL,FX,FZ or FS by screwing it on one of the conduit entries not used for electric cables and it can have many different functions:

Combined with a rope operated switch (for instance FL 678) it can indicate whether the switch has been actuated.

Combined with a key safety switch (for instance FL 693) it indicates whether the protection has been closed correctly or not.

Combined with a safety switch with solenoid (for instance FS 2096D024) it can indicate whether the protection is locked or unlocked.

Combined with any switch of the series FL, FX or FZ can be used to adjust the actuator that press the switch.

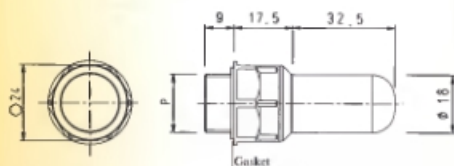

- Max operating voltage (Ui) 250 VAC/DC
- Max power of the lamp 3W
- Protection degree IP66
- Lamp type BA9
- Max. cross section of the cable 1,5 mm²
- Ambient temperature -25 °C ... +40 °C
- Driving torque 3 ... 4 Nm



5 pc. packs



VF ILI024GP

Lamp		Threaded couplings	
Kind of lamp		P	PG 13,5
I	Incandescence	M	M20 x 1,5
Supply voltage		Lamp color	
024	24 VAC/DC ± 10%	G	Yellow
110	110 VAC/DC ± 10%		
220	220 VAC/DC ± 10%		

Connectors

Connectors are used where a very short machine down time is critical (for example in big plants). The switch with connector can be replaced with an identical one very quickly, avoiding the possibility of incorrect wiring.

These standard male M12 connectors are ready for the installation on the switches. Their wires have the right length for the connection to the contact blocks and are provided with terminal pins. On request they can be delivered already wired to the switches.

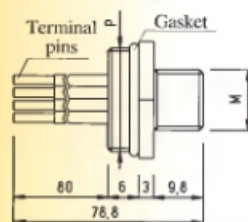

- Rated voltage (Ui) 250 VAC / 300 VDC (4 poles)
30 VAC / 36 VDC (5 poles)
- Rated current (Ith) 4A
- Protection degree IP68 (1 bar)
- Ambient temperature -25 ... +80 °C
- Number of poles 4 or 5
- Driving torque 1 ÷ 1,5 Nm



10 pc. packs



VF CNM5PM

⚠ Please contact our sales office since not all combination is available

Connector		Kind of coupling (M)	
Material		M	M12 x 1
M	Metal	Thread of the connector (P)	
P	Plastic	P	PG 13,5
Number of poles		M	M20 x 1,5
5	5 poles		
4	4 poles		

General data of the heavy series FD-FP-FL-FC

Cable glands

If the operating environment of the switch requires a protection degree against water or dust, the use of an adequate cable gland is recommended in order to guarantee a sufficient protection degree to the switch.

The IP protection degree of the cable gland shall be equal or higher than the IP protection degree of the switch.

Data

- Material of body and ring nut: Polymer glass-reinforced resin
- Protection degree: IP66
- Driving torque: 3 ... 4 Nm

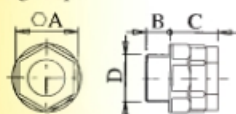

100 pc. packs



Article	Description	∅A	B	C	D
VF PG13,5	PG 13,5 cable gland for multipolar cables from ∅ 9 to ∅ 12 mm.	24	9	19	PG 13,5
VF PG13,5/6	PG 13,5 cable gland for multipolar cables from ∅ 6 to ∅ 9 mm.	24	9	19	PG 13,5
VF PG13,5/3	PG 13,5 cable gland for multipolar cables from ∅ 3 to ∅ 6 mm.	24	9	19	PG 13,5
VF PG11	PG 11 cable gland for multipolar cables from ∅ 6 to ∅ 9 mm.	22	7	16,5	PG 11
VF PG11/3	PG 11 cable gland for multipolar cables from ∅ 3 to ∅ 6 mm.	22	7	16,5	PG 11
VF PM20	M20x1,5 cable gland for multipolar cables from ∅ 9 to ∅ 12 mm.	24	9	19	M20x1,5
VF PM20/6	M20x1,5 cable gland for multipolar cables from ∅ 6 to ∅ 9 mm.	24	9	19	M20x1,5
VF PM20/3	M20x1,5 cable gland for multipolar cables from ∅ 3 to ∅ 6 mm.	24	9	19	M20x1,5
VF PM16	M16x1,5 cable gland for multipolar cables from ∅ 6 to ∅ 9 mm.	22	7	16,5	M16x1,5

Thread adapters

With these adapters it is possible to offer to the customers the same product with different threaded cable entries, while only having to stock a single product and many kinds of adapters.

Data

- Body material: Polymer glass-reinforced resin
- Driving torque: 3 ... 4 Nm

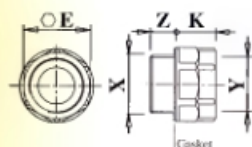

100 pc. packs



Article	Description	X	Y	Z	K	∅E
VF ADPG13-PG11	Adapter from PG 13,5 to PG 11	PG 13,5	PG 11	9	12	22
VF ADPG13-M20	Adapter from PG 13,5 to M20x1,5	PG 13,5	M20x1,5	9	14	24
VF ADPG13-1/2NPT	Adapter from PG 13,5 to 1/2 NPT	PG 13,5	1/2 NPT	9	14	24
VF ADPG11-1/2NPT	Adapter from PG 11 to 1/2 NPT	PG 11	1/2 NPT	7	14	24
VF ADPG11-PG13	Adapter from PG 11 to PG 13,5	PG 11	PG 13,5	7	14	24

Protection plugs

Data

- Body material : Polymer glass-reinforced resin
- Protection degree: IP66
- Driving torque: 1,2 ... 2 Nm

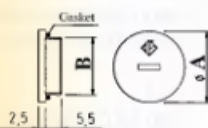

100 pc. packs



Article	Description	A	B
VF PTG13,5	Protection plug PG13,5	25	PG 13,5
VF PTM20	Protection plug M20x1,5	25	M20x1,5
VF PTG11	Protection plug PG11	23	PG 11
VF PTM16	Protection plug M16x1,5	23	M16x1,5

On request switches in special versions

- Versions with pre-wired connector made of plastic or metal.
- Special versions for -40°C use.
- Special versions with reduced pretravel.
- Versions with electronic contact block, see on page 137 .
- Some articles are available with some metallic or stainless steel parts.
- For the articles with head 31, 35 and 52 you may require plastic rollers $\text{O } 35 \text{ mm}$ or rubber roller $\text{O } 40 \text{ mm}$ and $\text{O } 50 \text{ mm}$.
- Special versions with reduced actuating force.
- Special versions with head oriented to the left, to the right or to the rear.
- Custom-made special versions.

 **For further information, please contact our technical service (see on page IV).**

Notes

Position switches FD series



Technical data

Housing

Made of metal, coated with baked epoxy powder
One conduit entry PG 13,5 or M20x1,5

Protection degree: IP66

General data

Ambient temperature: from -25°C to +80°C

Max operating frequency: 3600 operations/hour

Mechanical endurance: from 10 to 20 millions of operations

Electrical data

Thermal current (Ith): 10A

Rated insulation voltage (Ui): 500 VAC 600 VDC

400 VAC for B20 - B21 - B22

Protection against short circuits: fuse 10A 500V type aM

Pollution degree: 3

Utilization categories

Alternate current: AC15 (50...60Hz)

Ue(V) 250 400 500

Ie(A) 6 3 1

Direct current: DC13

Ue(V) 24 125 250

Ie(A) 6 1.1 0.4

Markings and quality marks:

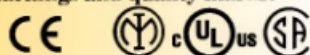

Approval type IMQ: EG605

Approval type UL: E131787

Approval type CSA: LR 93682-1

Conforms to the standards:

IEC 947-5-1, IEC 337-1, EN 60947-5-1, CEI EN 60947-5-1, CEI 17-45, EN 50041, CEI 17-31, IEC 204-1, EN 60204-1, CEI 44-5, EN 1088, EN 292, IEC 529, EN 60529, CEI 70-1, NCF 63-140, VDE 0660-200, VDE 0113, CENELEC EN 50013.

Approvals type:

IEC 947-5-1, UL 508, CSA C22-2 nr.14.

Complying with the requirements requested by:

Low Voltage Directive 73/23/EEC and subsequent modifications and completions, Machinery Directive 98/37/EEC. Electromagnetic Compatibility 89/336/EEC and subsequent modifications and completions.

Positive contact opening complying with the standards:

IEC 947-5-1, EN 60947-5-1, CEI EN 60947-5-1, VDE 0660-206.

Installation for safety applications :

Use only switches with the symbol "⊕" on their sides. Safety circuit must always be connected with the **NC contacts** (normally closed contacts: 11-12, 21-22 or 31-32) as stated in the **standard CEI EN 60947-5-1, encl. K, par. 2**. **The switch must be actuated with the minimum positive opening travel** shown in the travels diagrams on page 12. **The switch must be actuated with the minimum positive opening force**, shown in brackets, underneath each article, near the value of the min. force. For a correct installation of these articles see examples on page 231.

Data type approved by IMQ

- Rated insulation voltage (Ui) 500 VAC
400 VAC (for B20, B21, B22, B33, B34)
- Thermal current (Ith) 10A
- Protection against short circuits fuse 10A 500V type aM
- Protection degree of the housing IP66
- MV terminals (screw clamps)
- Pollution degree 3
- Utilization category AC15
- Operation voltage (Ue) 400 VAC (50 Hz)
- Operation current (Ie) 3A
- Forms of the contact element Za, Zb, Za+Za, Y+Y, X+X, Y+Y+X, Y+Y+Y, Y+X+X
- Positive opening of contacts on B5, B6, B7, B9, B11, B14, B16, B20, B21, B22, B33, B34
- Conforms to the standards: EN60947-1, EN 60947-1 A11, EN 60947-5-1 and fundamental requirements of the Low Voltage Directive 73/23 EEC and 93/68 EEC.

Please contact our technical service for the list of our type approved products

Data type approved by UL

- Utilization categories Q300 (69VA, 125-250 VDC)
A600 (720VA, 120-600 VAC)
- Data of the housing Type 1, 4X
(indoor use only), 12, 13
- Conforms to the standard: UL 508

Please contact our technical service for the list of our type approved products

Data type approved by CSA

- Utilization categories Q300 (69VA, 125-250 VDC)
A600 (720VA, 120-600 VAC)
- Data of the housing Type 1, 4X
(indoor use only), 12, 13
- Conforms to the standard: CSA C22-2 nr.14

Please contact our technical service for the list of our type approved products

Series FD
metal housing

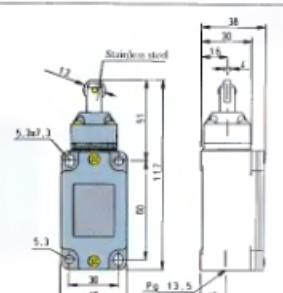
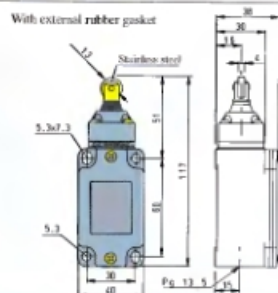
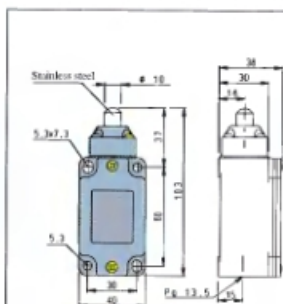

B5	Zb	snap action	FD 511	⊕	INO+INC	FD 515	⊕	INO+INC	FD 516	⊕	INO+INC	
B6	Zb	slow action	FD 611	⊕	INO+INC	FD 615	⊕	INO+INC	FD 616	⊕	INO+INC	
B7	Zb	slow action	FD 711	⊕	INO+INC Overlapped Contacts	FD 715	⊕	INO+INC Overlapped Contacts	FD 716	⊕	INO+INC Overlapped Contacts	
B9	Y+Y	slow action	FD 911	⊕	2NC	FD 915	⊕	2NC	FD 916	⊕	2NC	
B10	X+X	slow action	FD 1011		2NO	FD 1015		2NO	FD 1016		2NO	
B11	Y+Y	snap action	FD 1111	⊕	2NC	FD 1115	⊕	2NC	FD 1116	⊕	2NC	
B14	Y+Y	slow action	FD 1411	⊕	2NC Shifted Contacts	FD 1415	⊕	2NC Shifted Contacts	FD 1416	⊕	2NC Shifted Contacts	
B15	X+X	slow action	FD 1511		2NO Shifted Contacts	FD 1515		2NO Shifted Contacts	FD 1516		2NO Shifted Contacts	
B20	Y+Y+X	slow action	FD 2011	⊕	2NC+INO	FD 2015	⊕	2NC+INO	FD 2016	⊕	2NC+INO	
B21	Y+Y+Y	slow action	FD 2111	⊕	3NC	FD 2115	⊕	3NC	FD 2116	⊕	3NC	
B22	Y+X+X	slow action	FD 2211	⊕	INC+2NO	FD 2215	⊕	INC+2NO	FD 2216	⊕	INC+2NO	
B2	Za/Za	snap action	FD 211		INO-INC+INO-INC	FD 215		INO-INC+INO-INC	FD 216		INO-INC+INO-INC	
Max. speed				page 13 - type 4			page 13 - type 2			page 13 - type 2		
Min. force				8 N (20 N)			11 N (21 N)			8 N (20 N)		
Travel diagrams				page 12 - group 1			page 12 - group 1			page 12 - group 1		

Series FD
metal housing

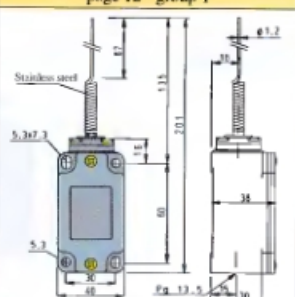
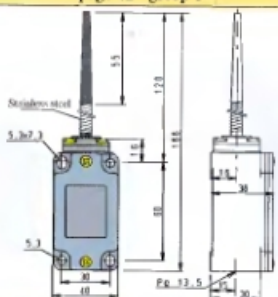
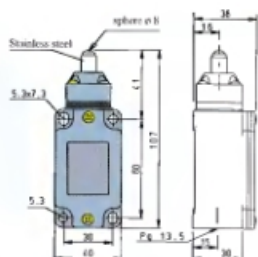

B5	Zb	snap action	FD 518	⊕	INO+INC	FD 520		INO+INC	FD 521		INO+INC	
B6	Zb	slow action	FD 618	⊕	INO+INC	/	/	/	/	/	/	
B7	Zb	slow action	FD 718	⊕	INO+INC Overlapped Contacts	/	/	/	/	/	/	
B9	Y+Y	slow action	FD 918	⊕	2NC	/	/	/	/	/	/	
B10	X+X	slow action	FD 1018		2NO	FD 1020		2NO	FD 1021		2NO	
B11	Y+Y	snap action	FD 1118	⊕	2NC	/	/	/	/	/	/	
B14	Y+Y	slow action	FD 1418	⊕	2NC Shifted Contacts	/	/	/	/	/	/	
B15	X+X	slow action	FD 1518		2NO Shifted Contacts	/	/	/	/	/	/	
B20	Y+Y+X	slow action	FD 2018	⊕	2NC+INO	FD 2020		2NC+INO	FD 2021		2NC+INO	
B21	Y+Y+Y	slow action	FD 2118	⊕	3NC	FD 2120		3NC	FD 2121		3NC	
B22	Y+X+X	slow action	FD 2218	⊕	INC+2NO	FD 2220		INC+2NO	FD 2221		INC+2NO	
B2	Za/Za	snap action	FD 218		INO-INC+INO-INC	FD 220		INO-INC+INO-INC	FD 221		INO-INC+INO-INC	
Max. speed				page 13 - type 4			1 m/s			1 m/s		
Min. force				8 N (20 N)			9 Ncm			8 Ncm		
Travel diagrams				page 12 - group 1			page 12 - group 3			page 12 - group 3		

Series FD
metal housing

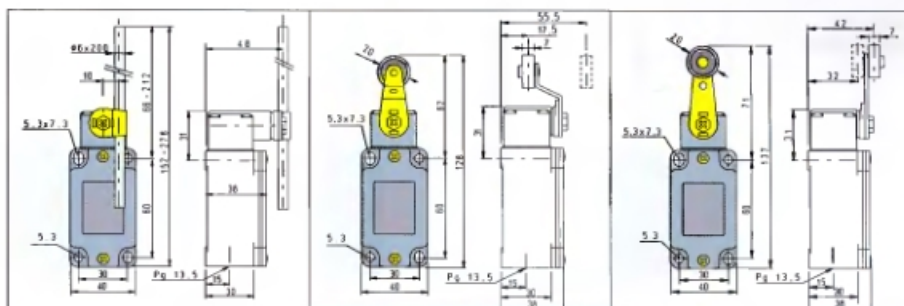

B5	Zb	snap action	FD 536	INO+INC	FD 551 ⊕	INO+INC	FD 552 ⊕	INO+INC
B6	Zb	slow action	FD 636	INO+INC	FD 651 ⊕	INO+INC	FD 652 ⊕	INO+INC
B7	Zb	slow action	FD 736	INO+INC Overlapped Contacts	FD 751 ⊕	INO+INC Overlapped Contacts	FD 752 ⊕	INO+INC Overlapped Contacts
B9	Y+Y	slow action	FD 936	2NC	FD 951 ⊕	2NC	FD 952 ⊕	2NC
B10	X+X	slow action	FD 1036	2NO	FD 1051	2NO	FD 1052	2NO
B11	Y+Y	snap action	FD 1136	2NC	FD 1151 ⊕	2NC	FD 1152 ⊕	2NC
B14	Y+Y	slow action	FD 1436	2NC Shifted Contacts	FD 1451 ⊕	2NC Shifted Contacts	FD 1452 ⊕	2NC Shifted Contacts
B15	X+X	slow action	FD 1536	2NO Shifted Contacts	FD 1551	2NO Shifted Contacts	FD 1552	2NO Shifted Contacts
B16	Y+Y	slow action	FD 1636	2NC Independent Contacts	/	/	/	/
B20	Y+Y+X	slow action	FD 2036	2NC+INO	FD 2051 ⊕	2NC+INO	FD 2052 ⊕	2NC+INO
B21	Y+Y+Y	slow action	FD 2136	3NC	FD 2151 ⊕	3NC	FD 2152 ⊕	3NC
B22	Y+X+X	slow action	FD 2236	1NC+2NO	FD 2251 ⊕	1NC+2NO	FD 2252 ⊕	1NC+2NO
B2	Za+Za	snap action	FD 236	INO-INC+INO-INC	FD 251	INO-INC+INO-INC	FD 252	INO-INC+INO-INC
Max. speed			1,5 m/s		page 13 - type 1		page 13 - type 1	
Min. force			15 Ncm		9 Ncm (25 Ncm)		9 Ncm (25 Ncm)	
Travel diagrams			page 12 - group 4		page 12 - group 4		page 12 - group 4	

Series FD
metal housing

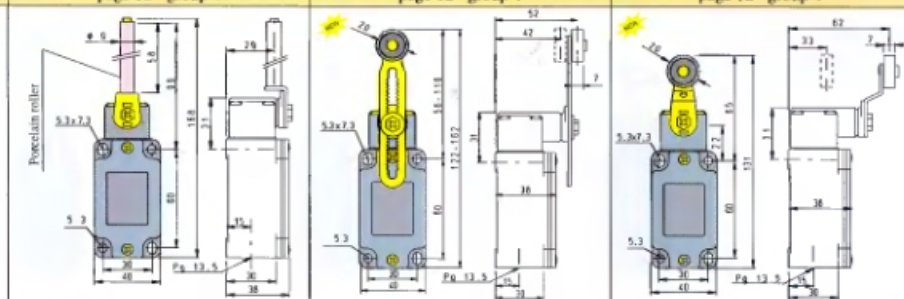

B5	Zb	snap action	FD 553 ⊕	INO+INC	FD 556 ⊕	INO+INC	FD 557 ⊕	INO+INC
B6	Zb	slow action	FD 653 ⊕	INO+INC	FD 656 ⊕	INO+INC	FD 657 ⊕	INO+INC
B7	Zb	slow action	FD 753 ⊕	INO+INC Overlapped Contacts	FD 756 ⊕	INO+INC Overlapped Contacts	FD 757 ⊕	INO+INC Overlapped Contacts
B9	Y+Y	slow action	FD 953 ⊕	2NC	FD 956 ⊕	2NC	FD 957 ⊕	2NC
B10	X+X	slow action	FD 1053	2NO	FD 1056	2NO	FD 1057	2NO
B11	Y+Y	snap action	FD 1153 ⊕	2NC	FD 1156 ⊕	2NC	FD 1157 ⊕	2NC
B14	Y+Y	slow action	FD 1453 ⊕	2NC Shifted Contacts	FD 1456 ⊕	2NC Shifted Contacts	FD 1457 ⊕	2NC Shifted Contacts
B15	X+X	slow action	FD 1553	2NO Shifted Contacts	FD 1556	2NO Shifted Contacts	FD 1557	2NO Shifted Contacts
B16	Y+Y	slow action	/	/	FD 1656 ⊕	2NC Independent Contacts	FD 1657 ⊕	2NC Independent Contacts
B20	Y+Y+X	slow action	FD 2053 ⊕	2NC+INO	FD 2056 ⊕	2NC+INO	FD 2057 ⊕	2NC+INO
B21	Y+Y+Y	slow action	FD 2153 ⊕	3NC	FD 2156 ⊕	3NC	FD 2157 ⊕	3NC
B22	Y+X+X	slow action	FD 2253 ⊕	1NC+2NO	FD 2256 ⊕	1NC+2NO	FD 2257 ⊕	1NC+2NO
B2	Za+Za	snap action	/	/	FD 256	INO-INC+INO-INC	FD 257	INO-INC+INO-INC
Max. speed			0,5 m/s		page 13 - type 1		page 13 - type 1	
Min. force			6 Ncm (25 Ncm)		15 Ncm (25 Ncm)		15 Ncm (25 Ncm)	
Travel diagrams			page 12 - group 5		page 12 - group 4		page 12 - group 4	

Series FD
metal housing

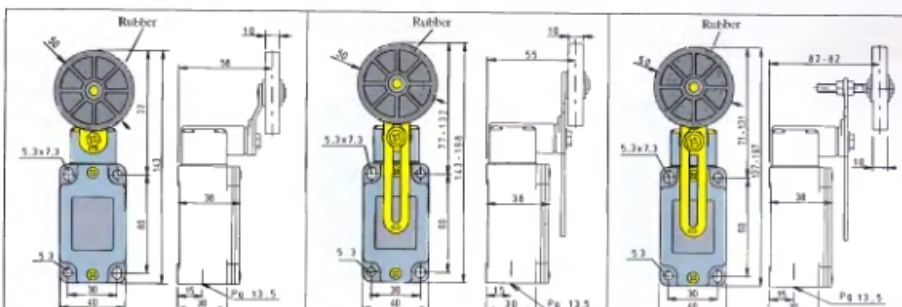

B5	Zb	snap action	FD 531-3	INO+INC	FD 535-3	INO+INC	FD 535-4	INO+INC
B6	Zb	slow action	FD 631-3	INO+INC	FD 635-3	INO+INC	FD 635-4	INO+INC
B7	Zb	slow action	FD 731-3	INO+INC Overlapped Contacts	FD 735-3	INO+INC Overlapped Contacts	FD 735-4	INO+INC Overlapped Contacts
B9	Y+Y	slow action	FD 931-3	2NC	FD 935-3	2NC	FD 935-4	2NC
B10	X+X	slow action	FD 1031-3	2NO	FD 1035-3	2NO	FD 1035-4	2NO
B11	Y+Y	snap action	FD 1131-3	2NC	FD 1135-3	2NC	FD 1135-4	2NC
B14	Y+Y	slow action	FD 1431-3	2NC Shifted Contacts	FD 1435-3	2NC Shifted Contacts	FD 1435-4	2NC Shifted Contacts
B15	X+X	slow action	FD 1531-3	2NO Shifted Contacts	FD 1535-3	2NO Shifted Contacts	FD 1535-4	2NO Shifted Contacts
B16	Y+Y	slow action	FD 1631-3	2NC Independent Contacts	FD 1635-3	2NC Independent Contacts	FD 1635-4	2NC Independent Contacts
B20	Y+Y+X	slow action	FD 2031-3	2NC+1NO	FD 2035-3	2NC+1NO	FD 2035-4	2NC+1NO
B21	Y+Y+Y	slow action	FD 2131-3	3NC	FD 2135-3	3NC	FD 2135-4	3NC
B22	Y+X+X	slow action	FD 2231-3	1NC+2NO	FD 2235-3	1NC+2NO	FD 2235-4	1NC+2NO
B2	Za+Za	snap action	FD 231-3	INO-INC+INO-INC	FD 235-3	INO-INC+INO-INC	FD 235-4	INO-INC+INO-INC
Max. speed			page 13 - type 1		page 13 - type 1		page 13 - type 1	
Min. force			15 Ncm (25 Ncm)		15 Ncm (25 Ncm)		15 Ncm (25 Ncm)	
Travel diagrams			page 12 - group 4		page 12 - group 4		page 12 - group 4	

Series FD
metal housing

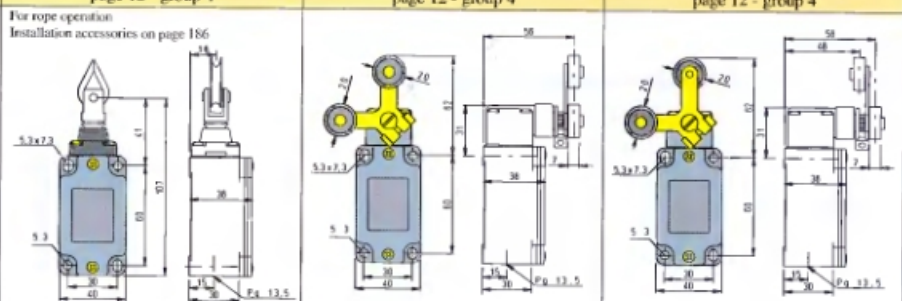

B5	Zb	snap action	FD 576	INO+INC	FD 541	INO+INC	FD 542	INO+INC
B6	Zb	slow action	FD 676	INO+INC	Lyra lever with single track		Lyra lever with double track	
B7	Zb	slow action	FD 776	INO+INC Overlapped Contacts				
B9	X+X	slow action	FD 976	2NO				
B10	Y+Y	slow action	FD 1076	2NC				
B11	X+X	snap action	FD 1176	2NO				
B14	X+X	slow action	FD 1476	2NO Shifted Contacts				
B15	Y+Y	slow action	FD 1576	2NC Shifted Contacts				
B20	Y+Y+X	slow action	FD 2076	1NC+2NO				
B21	X+X+X	slow action	FD 2176	3NO				
B22	Y+Y+X	slow action	FD 2276	2NC+1NO				
B2	Za+Za	snap action	FD 276	INO-INC+INO-INC				
Max. speed			0,5 m/s		0,5 m/s with cam 30°		0,5 m/s with cam 30°	
Min. force			Starting 20 N - Ultimate 40 N		21 Ncm		21 Ncm	
Travel diagrams			page 12 - group 6					

⊕ positive opening with lever adjusted on the max. position only. See on page 23

Position switches without actuator

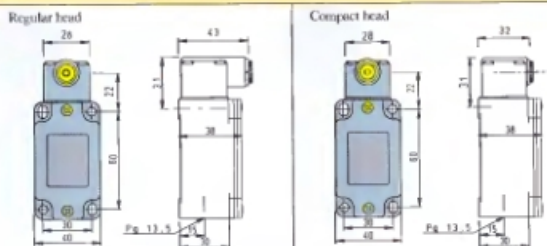

IMPORTANT:

For safety applications:
please combine only switches
and levers showing on the side
of their reference number the
symbol "⊕".

For more information about
safety applications see details
on page 231.

B5	Z _b	snap action	FD 538 ⊕ INO+INC	FD 558 ⊕ INO+INC
B6	Z _b	slow action	FD 638 ⊕ INO+INC	FD 658 ⊕ INO+INC
B7	Z _b	slow action	FD 738 ⊕ INO+INC Overlapped Contacts	FD 758 ⊕ INO+INC Overlapped Contacts
B9	Y+Y	slow action	FD 938 ⊕ 2NC	FD 958 ⊕ 2NC
B10	X+X	slow action	FD 1038 2NO	FD 1058 2NO
B11	Y+Y	snap action	FD 1138 ⊕ 2NC	FD 1158 ⊕ 2NC
B14	Y+Y	slow action	FD 1438 ⊕ 2NC Shifted Contacts	FD 1458 ⊕ 2NC Shifted Contacts
B15	X+X	slow action	FD 1538 2NO Shifted Contacts	FD 1558 2NO Shifted Contacts
B16	Y+Y	slow action	FD 1638 ⊕ 2NC Independent Contacts	/
B20	Y+Y+X	slow action	FD 2038 ⊕ 2NC+INO	FD 2058 ⊕ 2NC+INO
B21	Y+Y+Y	slow action	FD 2138 ⊕ 3NC	FD 2158 ⊕ 3NC
B22	Y+X+X	slow action	FD 2238 ⊕ INC+2NO	FD 2258 ⊕ INC+2NO
B2	Za+Za	snap action	FD 238 INO-INC+INO-INC	FD 258 INO-INC+INO-INC
Min. force			15 Ncm (25 Ncm)	9 Ncm (25 Ncm)
Travel diagrams			page 12 - group 4	page 12 - group 4

Loose actuators

IMPORTANT: These loose actuators can be used with items of series FD, FP, FL, FC only.

	With regular head only 	With regular head only 		With regular head only 	With regular head only
VF L31 ⊕ 10 pc	VF L32 10 pc	VF L33 10 pc	VF L34 10 pc	VF L35 ⊕ 10 pc	VF L36 10 pc
			With regular head only 		
VF L51 ⊕ 10 pc	VF L52 10 pc	VF L53 ⊕ 10 pc	VF L56 ⊕ 10 pc	VF L57 ⊕ 10 pc	

Quantities near the symbol indicate the number of pieces in each pack. Only orders for quantities multiple of the packs are accepted.

* Lever VF L35 suits to safety applications only if adjusted to its max. length, as you can see on the figure on the right:

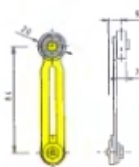

Position switches FP series



Technical data

Housing

Made of polymer glass-reinforced, self-extinguishing, shock proof thermoplastic resin and with double insulation. ☑

One conduit entry PG 13,5 or M20x1,5.

Protection degree: IP66

General data

Ambient temperature: from -25°C to +80°C

Max operating frequency: 3600 operations/hour

Mechanical endurance: from 10 to 20 millions of operations

Electrical data

Thermal current (I_{th}): 10A

Rated insulation voltage (U_i): 500 VAC 600 VDC
400 VAC for B20 - B21 - B22

Protection against short circuits: fuse 10A 500V type aM

Pollution degree: 3

Conforms to the standards:

IEC 947-5-1, IEC 337-1, EN 60947-5-1, CEI EN 60947-5-1, CEI 17-45, EN 50041, CEI 17-31, IEC 204-1, EN 60204-1, CEI 44-5, EN 1088, EN 292, IEC 529, EN 60529, CEI 70-1, NCF 63-140, VDE 0660-200, VDE 0113, CENELEC EN 50013.

Approval types:

IEC 947-5-1, UL 508, CSA C22-2 nr.14.

Utilization categories

Alternate current: AC15 (50...60Hz)

U_e(V) 250 400 500

I_e(A) 6 3 1

Direct current: DC13

U_e(V) 24 125 250

I_e(A) 6 1.1 0.4

Markings and quality marks:

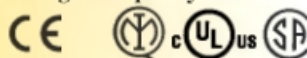

Approval type IMQ: EG606

Approval type UL: E131787

Approval type CSA: LR 93682-1

Complying with the requirements requested by:

Low Voltage Directive 73/23/EEC and subsequent modifications and completions, Machinery Directive 98/37/EEC, Electromagnetic Compatibility 89/336/EEC and subsequent modifications and completions.

Positive contact opening complying with the standards:

IEC 947-5-1, EN 60947-5-1, CEI EN 60947-5-1, VDE 0660-206.

Installation for safety applications :

Use only switches with the symbol "☉" on their sides. Safety circuit must always be connected with the **NC contacts** (normally closed contacts: 11-12, 21-22 or 31-32) as stated in the **standard CEI EN 60947-5-1, encl. K, par. 2**. The switch must be actuated with the **minimum positive opening travel** shown in the travels diagrams on page 12. The switch must be actuated with the **minimum positive opening force**, shown in brackets, underneath each article, near the value of the min. force. For a correct installation of these articles see examples on page 231.

Data type approved by IMQ

- Rated insulation voltage (U_i) 500 VAC
400 VAC (con B20, B21, B22, B33, B34)
- Thermal current (I_{th}) 10A
- Protection against short circuits fuse 10A 500V type aM
- Protection degree of the housing IP66
- MV terminals (screw clamps)
- Pollution degree 3
- Utilization category AC15
- Operation voltage (U_e) 400 VAC (50 Hz)
- Operation current (I_e) 3A
- Forms of the contact element Za, Zb, Za+Za, Y+Y, X+X, Y+Y+X, Y+Y+Y, Y+X+X
- Positive opening of contacts on B5, B6, B7, B9, B11, B14, B16, B20, B21, B22, B33, B34
- Conforms to the standards: EN60947-1, EN 60947-1 A11, EN 60947-5-1 and fundamental requirements of the Low Voltage Directive 73/23 EEC and 93/68 EEC.

Please contact our technical service for the list of our type approved products

Data type approved by UL

- Utilization categories Q300 (69VA, 125-250 VDC)
A600 (720VA, 120-600 VAC)
- Data of the housing Type 1, 4X
(indoor use only), 12, 13
- Conforms to the standard: UL 508

Please contact our technical service for the list of our type approved products

Data type approved by CSA

- Utilization categories Q300 (69VA, 125-250 VDC)
A600 (720VA, 120-600 VAC)
- Data of the housing Type 1, 4X
(indoor use only), 12, 13
- Conforms to the standard: CSA C22-2 nr.14

Please contact our technical service for the list of our type approved products

FP series
polymer housing

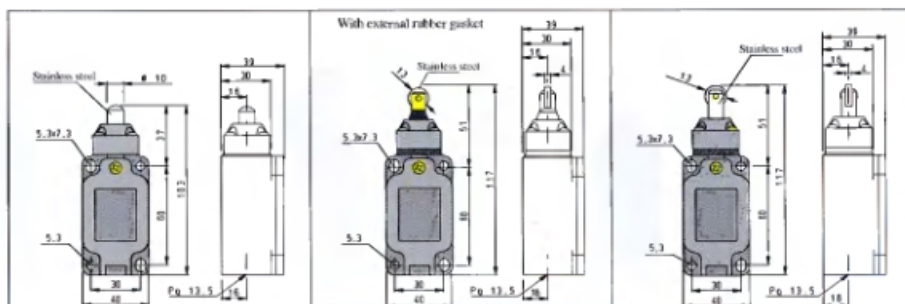

B5	Zb	snap action	FP 511	⊕ INO+INC	FP 515	⊕ INO+INC	FP 516	⊕ INO+INC
B6	Zb	slow action	FP 611	⊕ INO+INC	FP 615	⊕ INO+INC	FP 616	⊕ INO+INC
B7	Zb	slow action	FP 711	⊕ INO+INC Overlapped Contacts	FP 715	⊕ INO+INC Overlapped Contacts	FP 716	⊕ INO+INC Overlapped Contacts
B9	Y+Y	slow action	FP 911	⊕ 2NC	FP 915	⊕ 2NC	FP 916	⊕ 2NC
B10	X+X	slow action	FP 1011	2NO	FP 1015	2NO	FP 1016	2NO
B11	Y+Y	snap action	FP 1111	⊕ 2NC	FP 1115	⊕ 2NC	FP 1116	⊕ 2NC
B14	Y+Y	slow action	FP 1411	⊕ 2NC Shifted Contacts	FP 1415	⊕ 2NC Shifted Contacts	FP 1416	⊕ 2NC Shifted Contacts
B15	X+X	slow action	FP 1511	2NO Shifted Contacts	FP 1515	2NO Shifted Contacts	FP 1516	2NO Shifted Contacts
B20	Y+Y+X	slow action	FP 2011	⊕ 2NC+1NO	FP 2015	⊕ 2NC+1NO	FP 2016	⊕ 2NC+1NO
B21	Y+Y+Y	slow action	FP 2111	⊕ 3NC	FP 2115	⊕ 3NC	FP 2116	⊕ 3NC
B22	Y+X+X	slow action	FP 2211	⊕ 1NC+2NO	FP 2215	⊕ 1NC+2NO	FP 2216	⊕ 1NC+2NO
B2	Za+Za	snap action	FP 211	1NO-1NC+1NO-1NC	FP 215	1NO-1NC+1NO-1NC	FP 216	1NO-1NC+1NO-1NC
Max. speed			page 13 - type 4		page 13 - type 2		page 13 - type 2	
Min. force			8 N (20 N)		11 N (21 N)		8 N (20 N)	
Travel diagrams			page 12 - group 1		page 12 - group 1		page 12 - group 1	

FP series
polymer housing

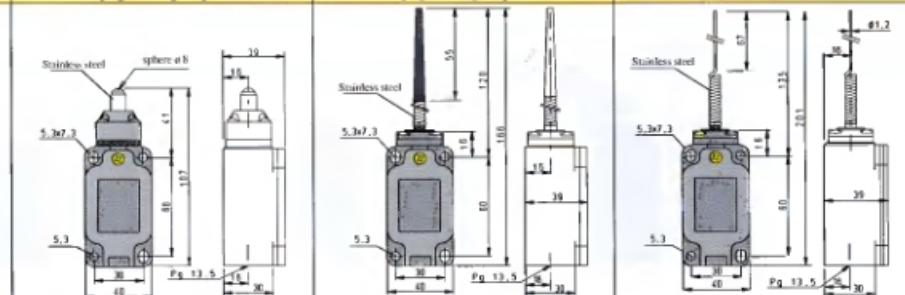

B5	Zb	snap action	FP 518	⊕ INO+INC	FP 520	1NO+1NC	FP 521	1NO+1NC
B6	Zb	slow action	FP 618	⊕ 1NO+1NC	/	/	/	/
B7	Zb	slow action	FP 718	⊕ 1NO+1NC Overlapped Contacts	/	/	/	/
B9	Y+Y	slow action	FP 918	⊕ 2NC	/	/	/	/
B10	X+X	slow action	FP 1018	2NO	FP 1020	2NO	FP 1021	2NO
B11	Y+Y	snap action	FP 1118	⊕ 2NC	/	/	/	/
B14	Y+Y	slow action	FP 1418	⊕ 2NC Shifted Contacts	/	/	/	/
B15	X+X	slow action	FP 1518	2NO Shifted Contacts	/	/	/	/
B20	Y+Y+X	slow action	FP 2018	⊕ 2NC+1NO	FP 2020	2NC+1NO	FP 2021	2NC+1NO
B21	Y+Y+Y	slow action	FP 2118	⊕ 3NC	FP 2120	3NC	FP 2121	3NC
B22	Y+X+X	slow action	FP 2218	⊕ 1NC+2NO	FP 2220	1NC+2NO	FP 2221	1NC+2NO
B2	Za+Za	snap action	FP 218	1NO-1NC+1NO-1NC	FP 220	1NO-1NC+1NO-1NC	FP 221	1NO-1NC+1NO-1NC
Max. speed			page 13 - type 4		1 m/s		1 m/s	
Min. force			8 N (20 N)		9 Ncm		8 Ncm	
Travel diagrams			page 12 - group 1		page 12 - group 3		page 12 - group 3	

FP series
polymer housing

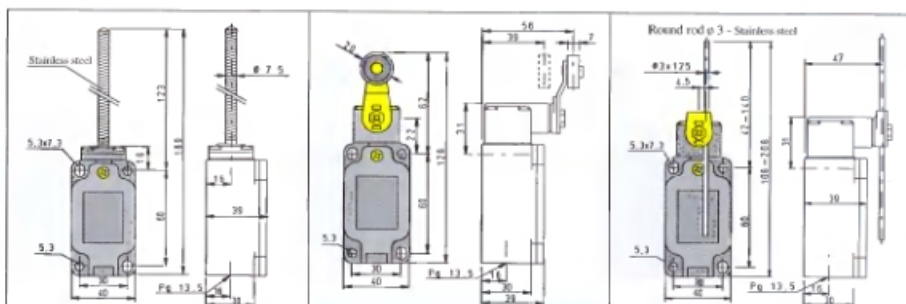

B5	Zb	snap action	FP 525	INO+INC	FP 531 ⊕	INO+INC	FP 532	INO+INC
B6	Zb	slow action	/	/	FP 631	INO+INC	FP 632	INO+INC
B7	Zb	slow action	/	/	FP 731	INO+INC Overlapped Contacts	FP 732	INO+INC Overlapped Contacts
B9	Y+Y	slow action	/	/	FP 931	2NC	FP 932	2NC
B10	X+X	slow action	FP 1025	2NO	FP 1031	2NO	FP 1032	2NO
B11	Y+Y	snap action	/	/	FP 1131	2NC	FP 1132	2NC
B14	Y+Y	slow action	/	/	FP 1431	2NC Shifted Contacts	FP 1432	2NC Shifted Contacts
B15	X+X	slow action	/	/	FP 1531	2NO Shifted Contacts	FP 1532	2NO Shifted Contacts
B16	Y+Y	slow action	/	/	FP 1631	2NC Independent Contacts	FP 1632	2NC Independent Contacts
B20	Y+Y+X	slow action	FP 2025	2NC+INO	FP 2031	2NC+INO	FP 2032	2NC+INO
B21	Y+Y+Y	slow action	FP 2125	3NC	FP 2131	3NC	FP 2132	3NC
B22	Y+X+X	slow action	FP 2225	INC+2NO	FP 2231	INC+2NO	FP 2232	INC+2NO
B2	ZaZa	snap action	FP 225	INO-INC+INO-INC	FP 231	INO-INC+INO-INC	FP 232	INO-INC+INO-INC
Max. speed			1 m/s		page 13 - type 1		1,5 m/s	
Min. force			14 Ncm		15 Ncm (25 Ncm)		15 Ncm	
Travel diagrams			page 12 - group 3		page 12 - group 4		page 12 - group 4	

FP series
polymer housing

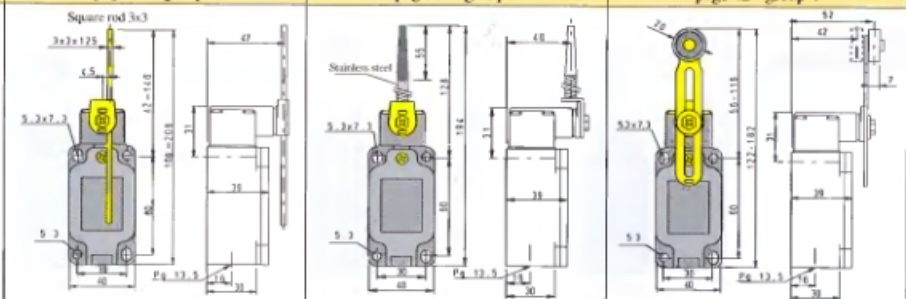

B5	Zb	snap action	FP 533	INO+INC	FP 534	INO+INC	FP 535	⊕* INO+INC
B6	Zb	slow action	FP 633	INO+INC	FP 634	INO+INC	FP 635	⊕* INO+INC
B7	Zb	slow action	FP 733	INO+INC Overlapped Contacts	FP 734	INO+INC Overlapped Contacts	FP 735	⊕* INO+INC Overlapped Contacts
B9	Y+Y	slow action	FP 933	2NC	FP 934	2NC	FP 935	⊕* 2NC
B10	X+X	slow action	FP 1033	2NO	FP 1034	2NO	FP 1035	2NO
B11	Y+Y	snap action	FP 1133	2NC	FP 1134	2NC	FP 1135	⊕* 2NC
B14	Y+Y	slow action	FP 1433	2NC Shifted Contacts	FP 1434	2NC Shifted Contacts	FP 1435	⊕* 2NC Shifted Contacts
B15	X+X	slow action	FP 1533	2NO Shifted Contacts	FP 1534	2NO Shifted Contacts	FP 1535	2NO Shifted Contacts
B16	Y+Y	slow action	FP 1633	2NC Independent Contacts	FP 1634	2NC Independent Contacts	FP 1635	⊕* 2NC Independent Contacts
B20	Y+Y+X	slow action	FP 2033	2NC+INO	FP 2034	2NC+INO	FP 2035	⊕* 2NC+INO
B21	Y+Y+Y	slow action	FP 2133	3NC	FP 2134	3NC	FP 2135	⊕* 3NC
B22	Y+X+X	slow action	FP 2233	INC+2NO	FP 2234	INC+2NO	FP 2235	⊕* INC+2NO
B2	ZaZa	snap action	FP 233	INO-INC+INO-INC	FP 234	INO-INC+INO-INC	FP 235	INO-INC+INO-INC
Max. speed			1,5 m/s		1 m/s		page 13 - type 1	
Min. force			15 Ncm		15 Ncm		15 Ncm (25 Ncm)	
Travel diagrams			page 12 - group 4		page 12 - group 4		page 12 - group 4	

⊕* positive opening with lever adjusted on the max. position only. See on page 31

FP series
polymer housing

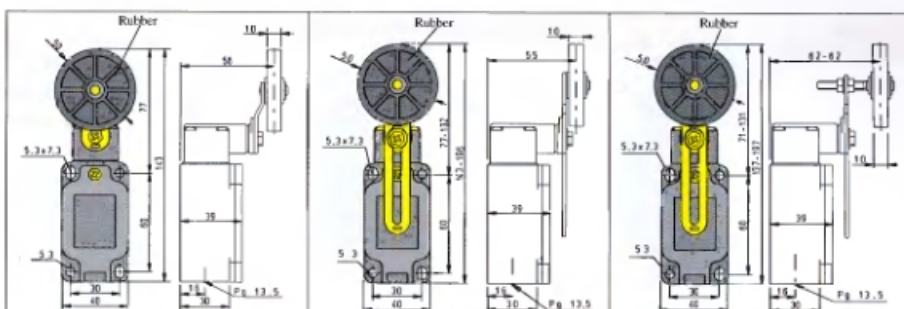

B5	Zb snap action	FP 531-3	INO+INC	FP 535-3	INO+INC	FP 535-4	INO+INC
B6	Zb slow action	FP 631-3	INO+INC	FP 635-3	INO+INC	FP 635-4	INO+INC
B7	Zb slow action	FP 731-3	INO+INC Overlapped Contacts	FP 735-3	INO+INC Overlapped Contacts	FP 735-4	INO+INC Overlapped Contacts
B9	Y+Y slow action	FP 931-3	2NC	FP 935-3	2NC	FP 935-4	2NC
B10	X+X slow action	FP 1031-3	2NO	FP 1035-3	2NO	FP 1035-4	2NO
B11	Y+Y snap action	FP 1131-3	2NC	FP 1135-3	2NC	FP 1135-4	2NC
B14	Y+Y slow action	FP 1431-3	2NC Shifted Contacts	FP 1435-3	2NC Shifted Contacts	FP 1435-4	2NC Shifted Contacts
B15	X+X slow action	FP 1531-3	2NO Shifted Contacts	FP 1535-3	2NO Shifted Contacts	FP 1535-4	2NO Shifted Contacts
B16	Y+Y slow action	FP 1631-3	2NC Independent Contacts	FP 1635-3	2NC Independent Contacts	FP 1635-4	2NC Independent Contacts
B20	Y+Y+X slow action	FP 2031-3	2NC+1NO	FP 2035-3	2NC+1NO	FP 2035-4	2NC+1NO
B21	Y+Y+Y slow action	FP 2131-3	3NC	FP 2135-3	3NC	FP 2135-4	3NC
B22	Y+X+X slow action	FP 2231-3	1NC+2NO	FP 2235-3	1NC+2NO	FP 2235-4	1NC+2NO
B2	Za+Za snap action	FP 231-3	INO-INC+INO-INC	FP 235-3	INO-INC+INO-INC	FP 235-4	INO-INC+INO-INC
Max. speed		page 13 - type 1		page 13 - type 1		page 13 - type 1	
Min. force		15 Ncm (25 Ncm)		15 Ncm (25 Ncm)		15 Ncm (25 Ncm)	
Travel diagrams		page 12 - group 4		page 12 - group 4		page 12 - group 4	

FP series
polymer housing

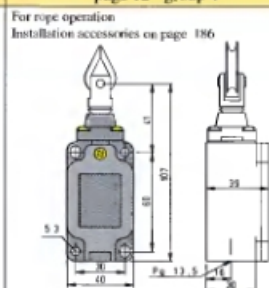

B5	Zb snap action	FP 576	INO+INC				
B6	Zb slow action	FP 676	INO+INC				
B7	Zb slow action	FP 776	INO+INC Overlapped Contacts				
B9	X+X slow action	FP 976	2NO				
B10	Y+Y slow action	FP 1076	2NC				
B11	X+X snap action	FP 1176	2NO				
B14	X+X slow action	FP 1476	2NO Shifted Contacts				
B15	Y+Y slow action	FP 1576	2NC Shifted Contacts				
B20	Y+X+X slow action	FP 2076	1NC+2NO				
B21	X+X+X slow action	FP 2176	3NO				
B22	Y+Y+X slow action	FP 2276	2NC+1NO				
B2	Za+Za snap action	FP 276	INO-INC+INO-INC				
Max. speed		0,5 m/s					
Min. force		Initial 20 N - Final 40 N					
Travel diagrams		page 12 - group 6					

⊕ positive opening with lever adjusted on the max. position only. See on page 31

Position switches without actuator

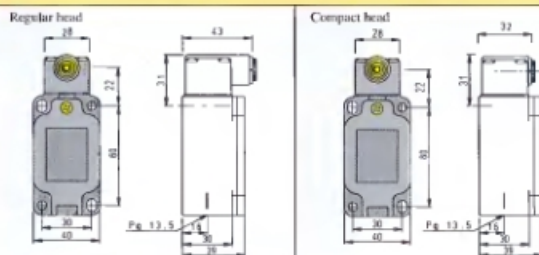

IMPORTANT:

For safety applications: please combine only switches and levers showing on the side of their reference number the symbol "⊕".

For more information about safety applications see details on page 231.

B5	Zb	snap action	FP 538 ⊕	INO+INC	FP 558 ⊕	INO+INC
B6	Zb	slow action	FP 638 ⊕	INO+INC	FP 658 ⊕	INO+INC
B7	Zb	slow action	FP 738 ⊕	INO+INC Overlapped Contacts	FP 758 ⊕	INO+INC Overlapped Contacts
B9	Y+Y	slow action	FP 938 ⊕	2NC	FP 958 ⊕	2NC
B10	X+X	slow action	FP 1038	2NO	FP 1058	2NO
B11	Y+Y	snap action	FP 1138 ⊕	2NC	FP 1158 ⊕	2NC
B14	Y+Y	slow action	FP 1438 ⊕	2NC Shifted Contacts	FP 1458 ⊕	2NC Shifted Contacts
B15	X+X	slow action	FP 1538	2NO Shifted Contacts	FP 1558	2NO Shifted Contacts
B16	Y+Y	slow action	FP 1638 ⊕	2NC Independent Contacts	/	/
B20	Y+Y+X	slow action	FP 2038 ⊕	2NC+1NO	FP 2058 ⊕	2NC+1NO
B21	Y+Y+Y	slow action	FP 2138 ⊕	3NC	FP 2158 ⊕	3NC
B22	Y+X+X	slow action	FP 2238 ⊕	INC+2NO	FP 2258 ⊕	INC+2NO
B2	Za+Za	snap action	FP 238	INO-INC+INO-INC	FP 258	INO-INC+INO-INC
Min. force	15 Ncm (25 Ncm)			9 Ncm (25 Ncm)		
Travel diagrams	page 12 - group 4			page 12 - group 4		

Loose actuators

IMPORTANT: These loose actuators can be used with items of series FD, FP, FL, FC only.

	With regular head only 	With regular head only 		With regular head only 	With regular head only
VF L31 ⊕ 10 pc	VF L32 10 pc	VF L33 10 pc	VF L34 10 pc	VF L35 ⊕ * 10 pc	VF L36 10 pc
			With regular head only 		
VF L51 ⊕ 10 pc	VF L52 ⊕ 10 pc	VF L53 ⊕ 10 pc	VF L56 ⊕ 10 pc	VF L57 ⊕ 10 pc	

Quantities near the symbol indicate the number of pieces in each pack. Only orders for quantities multiple of the packs are accepted.

* Lever VF L35 suits to safety applications only if adjusted to its max. length, as you can see on the figure on the right:

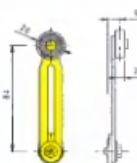

Position switches FL series



Technical data

Housing

Made of metal, coated with baked epoxy powder.
Three conduit entries PG 13,5 or M20x1,5.

Protection degree: IP66

General data

Ambient temperature: from -25°C to +80°C

Max operating frequency: 3600 operations/hour

Mechanical endurance: from 10 to 20 millions of operations

Electrical data

Thermal current (Ith): 10A

Rated insulation voltage (Ui): 500 VAC 600 VDC

400 VAC for B20 - B21 - B22

Protection against short circuits: fuse 10A 500V type aM

Pollution degree: 3

Conforms to the standards:

IEC 947-5-1, IEC 337-1, EN 60947-5-1, CEI EN 60947-5-1, CEI 17-45, CEI 17-31, IEC 204-1, EN 60204-1, CEI 44-5, EN 1088, EN 292, IEC 529, EN 60529, CEI 70-1, NCF 63-140, VDE 0660-200, VDE 0113, CENELEC EN 50013.

Approval types:

IEC 947-5-1, UL 508, CSA C22-2 nr.14.

Utilization categories

Alternate current: AC15 (50...60Hz)

Ue(V) 250 400 500

Ie(A) 6 3 1

Direct current: DC13

Ue(V) 24 125 250

Ie(A) 6 1.1 0.4

Markings and quality marks:

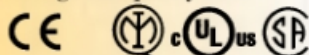

Approval type IMQ: EG607

Approval type UL: E131787

Approval type CSA: LR 93682-1

Complying with the requirements requested by:

Low Voltage Directive 73/23/EEC and subsequent modifications and completions, Machinery Directive 98/37/EEC, Electromagnetic Compatibility 89/336/EEC and subsequent modifications and completions.

Positive contact opening complying with the standards:

IEC 947-5-1, EN 60947-5-1, CEI EN 60947-5-1, VDE 0660-206.

Installation for safety applications :

Use only switches with the symbol "⊕" on their sides. Safety circuit must always be connected with the NC contacts (normally closed contacts: 11-12, 21-22 or 31-32) as stated in the standard CEI EN 60947-5-1, encl. K, par. 2. The switch must be actuated with the minimum positive opening travel shown in the travels diagrams on page 12. The switch must be actuated with the minimum positive opening force, shown in brackets, underneath each article, near the value of the min. force. For a correct installation of these articles see examples on page 231.

Data type approved by IMQ

- Rated insulation voltage (Ui) 500 VAC
400 VAC (con B20, B21, B22, B33, B34)
- Thermal current (Ith) 10A
- Protection against short circuits fuse 10A 500V type aM
- Protection degree of the housing IP66
- MV terminals (screw clamps)
- Pollution degree 3
- Utilization category AC15
- Operation voltage (Ue) 400 VAC (50 Hz)
- Operation current (Ie) 3A
- Forms of the contact element Za, Zb, Za+Za, Y+Y, X+X, Y+Y+X, Y+Y+Y, Y+X+X
- Positive opening of contacts on B5, B6, B7, B9, B11, B14, B16, B20, B21, B22, B33, B34
- Conforms to the standards: EN60947-1, EN 60947-1 A11, EN 60947-5-1 and fundamental requirements of the Low Voltage Directive 73/23 EEC and 93/68 EEC.

Please contact our technical service for the list of our type approved products

Data type approved by UL

- Utilization categories Q300 (69VA, 125-250 VDC)
A600 (720VA, 120-600 VAC)
- Data of the housing Type 1, 4X
(indoor use only), 12, 13
- Conforms to the standard: UL 508

Please contact our technical service for the list of our type approved products

Data type approved by CSA

- Utilization categories Q300 (69VA, 125-250 VDC)
A600 (720VA, 120-600 VAC)
- Data of the housing Type 1, 4X
(indoor use only), 12, 13
- Conforms to the standard: CSA C22-2 nr.14

Please contact our technical service for the list of our type approved products

**FL series
metal housing**

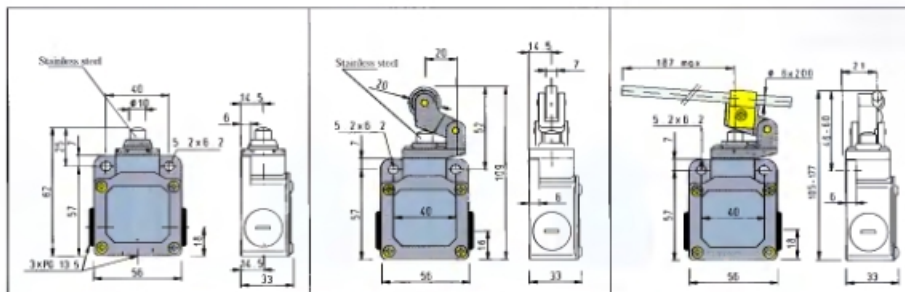

B5 Zb snap action	FL 501 \oplus INO+INC	FL 502 \oplus INO+INC	FL 504 INO+INC
B6 Zb slow action	FL 601 \oplus INO+INC	FL 602 \oplus INO+INC	FL 604 INO+INC
B7 Zb slow action	FL 701 \oplus INO+INC Overlapped Contacts	FL 702 \oplus INO+INC Overlapped Contacts	FL 704 INO+INC Overlapped Contacts
B9 Y+Y slow action	FL 901 \oplus 2NC	FL 902 \oplus 2NC	FL 904 2NC
B10 X+X slow action	FL 1001 2NO	FL 1002 2NO	FL 1004 2NO
B11 Y+Y snap action	FL 1101 \oplus 2NC	FL 1102 \oplus 2NC	FL 1104 2NC
B14 Y+Y slow action	FL 1401 \oplus 2NC Shifted Contacts	FL 1402 \oplus 2NC Shifted Contacts	FL 1404 2NC Shifted Contacts
B15 X+X slow action	FL 1501 2NO Shifted Contacts	FL 1502 2NO Shifted Contacts	FL 1504 2NO Shifted Contacts
B20 Y+Y+X slow action	FL 2001 \oplus 2NC+1NO	FL 2002 \oplus 2NC+1NO	FL 2004 2NC+1NO
B21 Y+Y+Y slow action	FL 2101 \oplus 3NC	FL 2102 \oplus 3NC	FL 2104 3NC
B22 Y+X+X slow action	FL 2201 \oplus 1NC+2NO	FL 2202 \oplus 1NC+2NO	FL 2204 1NC+2NO
B2 Za/Za snap action	FL 201 1NO-1NC+1NO-1NC	FL 202 1NO-1NC+1NO-1NC	FL 204 1NO-1NC+1NO-1NC
Max. speed	page 13 - type 4		1 m/s with cam 30°
Min. force	8 N (20 N)		6 N (20 N)
Travel diagrams	page 12 - group 1		page 12 - group 1

**FL series
metal housing**

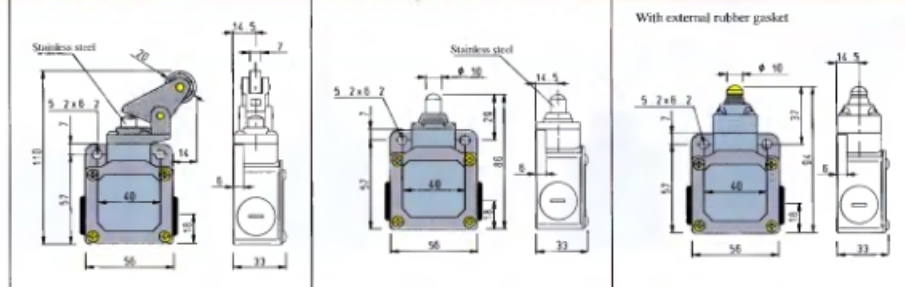

B5 Zb snap action	FL 505 \oplus INO+INC	FL 508 \oplus INO+INC	FL 510 \oplus INO+INC
B6 Zb slow action	FL 605 \oplus INO+INC	FL 608 \oplus INO+INC	FL 610 \oplus INO+INC
B7 Zb slow action	FL 705 \oplus INO+INC Overlapped Contacts	FL 708 \oplus INO+INC Overlapped Contacts	FL 710 \oplus INO+INC Overlapped Contacts
B9 Y+Y slow action	FL 905 \oplus 2NC	FL 908 \oplus 2NC	FL 910 \oplus 2NC
B10 X+X slow action	FL 1005 2NO	FL 1008 2NO	FL 1010 2NO
B11 Y+Y snap action	FL 1105 \oplus 2NC	FL 1108 \oplus 2NC	FL 1110 \oplus 2NC
B14 Y+Y slow action	FL 1405 \oplus 2NC Shifted Contacts	FL 1408 \oplus 2NC Shifted Contacts	FL 1410 \oplus 2NC Shifted Contacts
B15 X+X slow action	FL 1505 2NO Shifted Contacts	FL 1508 2NO Shifted Contacts	FL 1510 2NO Shifted Contacts
B20 Y+Y+X slow action	FL 2005 \oplus 2NC+1NO	FL 2008 \oplus 2NC+1NO	FL 2010 \oplus 2NC+1NO
B21 Y+Y+Y slow action	FL 2105 \oplus 3NC	FL 2108 \oplus 3NC	FL 2110 \oplus 3NC
B22 Y+X+X slow action	FL 2205 \oplus 1NC+2NO	FL 2208 \oplus 1NC+2NO	FL 2210 \oplus 1NC+2NO
B2 Za/Za snap action	FL 205 1NO-1NC+1NO-1NC	FL 208 1NO-1NC+1NO-1NC	FL 210 1NO-1NC+1NO-1NC
Max. speed	page 13 - type 3		page 13 - type 4
Min. force	6 N (20 N)		11 N (21 N)
Travel diagrams	page 12 - group 2		page 12 - group 1

Items with code on the green background are available in stock.

FL series
metal housing

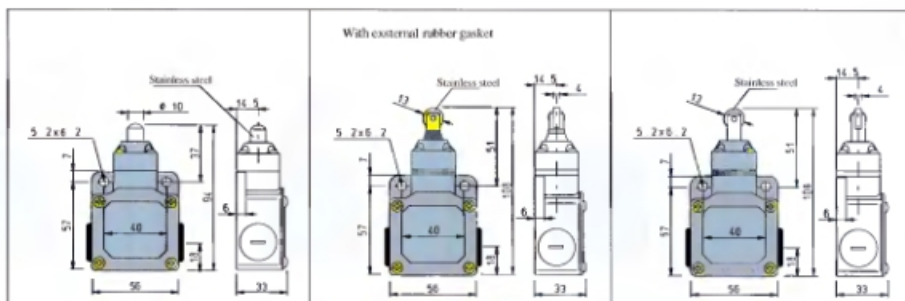

B5	Zb snap action	FL 511	INO+INC	FL 515	INO+INC	FL 516	INO+INC
B6	Zb slow action	FL 611	INO+INC	FL 615	INO+INC	FL 616	INO+INC
B7	Zb slow action	FL 711	INO+INC Overlapped Contacts	FL 715	INO+INC Overlapped Contacts	FL 716	INO+INC Overlapped Contacts
B9	Y+Y slow action	FL 911	2NC	FL 915	2NC	FL 916	2NC
B10	X+X slow action	FL 1011	2NO	FL 1015	2NO	FL 1016	2NO
B11	Y+Y snap action	FL 1111	2NC	FL 1115	2NC	FL 1116	2NC
B14	Y+Y slow action	FL 1411	2NC Shifted Contacts	FL 1415	2NC Shifted Contacts	FL 1416	2NC Shifted Contacts
B15	X+X slow action	FL 1511	2NO Shifted Contacts	FL 1515	2NO Shifted Contacts	FL 1516	2NO Shifted Contacts
B20	Y+Y+X slow action	FL 2011	2NC+1NO	FL 2015	2NC+1NO	FL 2016	2NC+1NO
B21	Y+Y+Y slow action	FL 2111	3NC	FL 2115	3NC	FL 2116	3NC
B22	Y+X+X slow action	FL 2211	1NC+2NO	FL 2215	1NC+2NO	FL 2216	1NC+2NO
B2	Za+Za snap action	FL 211	1NO-1NC+1NO-1NC	FL 215	1NO-1NC+1NO-1NC	FL 216	1NO-1NC+1NO-1NC
Max. speed		page 13 - type 4		page 13 - type 2		page 13 - type 2	
Min. force		8 N (20 N)		11 N (21 N)		8 N (20 N)	
Travel diagrams		page 12 - group 1		page 12 - group 1		page 12 - group 1	

FL series
metal housing

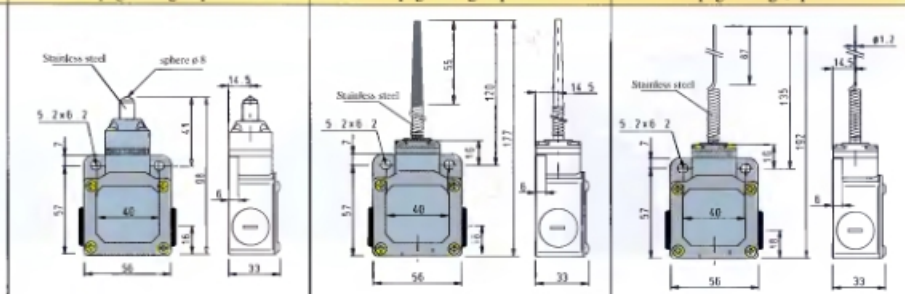

B5	Zb snap action	FL 518	INO+INC	FL 520	INO+INC	FL 521	INO+INC
B6	Zb slow action	FL 618	INO+INC	/	/	/	/
B7	Zb slow action	FL 718	INO+INC Overlapped Contacts	/	/	/	/
B9	Y+Y slow action	FL 918	2NC	/	/	/	/
B10	X+X slow action	FL 1018	2NO	FL 1020	2NO	FL 1021	2NO
B11	Y+Y snap action	FL 1118	2NC	/	/	/	/
B14	Y+Y slow action	FL 1418	2NC Shifted Contacts	/	/	/	/
B15	X+X slow action	FL 1518	2NO Shifted Contacts	/	/	/	/
B20	Y+Y+X slow action	FL 2018	2NC+1NO	FL 2020	2NC+1NO	FL 2021	2NC+1NO
B21	Y+Y+Y slow action	FL 2118	3NC	FL 2120	3NC	FL 2121	3NC
B22	Y+X+X slow action	FL 2218	1NC+2NO	FL 2220	1NC+2NO	FL 2221	1NC+2NO
B2	Za+Za snap action	FL 218	1NO-1NC+1NO-1NC	FL 220	1NO-1NC+1NO-1NC	FL 221	1NO-1NC+1NO-1NC
Max. speed		page 13 - type 4		1 m/s		1 m/s	
Min. force		8 N (20 N)		9 Ncm		8 Ncm	
Travel diagrams		page 12 - group 1		page 12 - group 3		page 12 - group 3	

FL series
metal housing

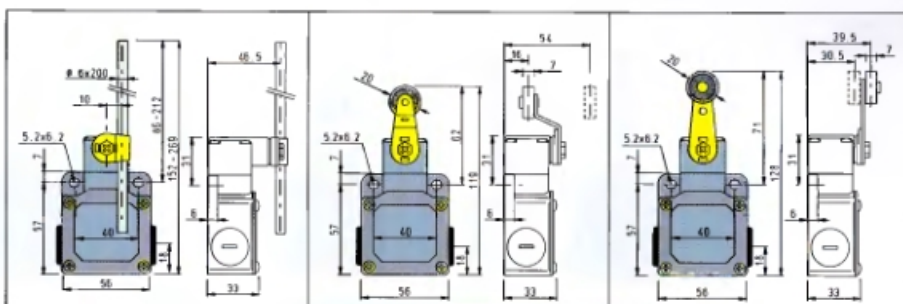

B5	Zb snap action	FL 536	1NO+1NC	FL 551 ⊕	1NO+1NC	FL 552 ⊕	1NO+1NC
B6	Zb slow action	FL 636	1NO+1NC	FL 651 ⊕	1NO+1NC	FL 652 ⊕	1NO+1NC
B7	Zb slow action	FL 736	1NO+1NC Overlapped Contacts	FL 751 ⊕	1NO+1NC Overlapped Contacts	FL 752 ⊕	1NO+1NC Overlapped Contacts
B9	Y+Y slow action	FL 936	2NC	FL 951 ⊕	2NC	FL 952 ⊕	2NC
B10	X+X slow action	FL 1036	2NO	FL 1051	2NO	FL 1052	2NO
B11	Y+Y snap action	FL 1136	2NC	FL 1151 ⊕	2NC	FL 1152 ⊕	2NC
B14	Y+Y slow action	FL 1436	2NC Shifted Contacts	FL 1451 ⊕	2NC Shifted Contacts	FL 1452 ⊕	2NC Shifted Contacts
B15	X+X slow action	FL 1536	2NO Shifted Contacts	FL 1551	2NO Shifted Contacts	FL 1552	2NO Shifted Contacts
B16	Y+Y slow action	FL 1636	2NC Independent Contacts	/	/	/	/
B20	Y+Y+X slow action	FL 2036	2NC+1NO	FL 2051 ⊕	2NC+1NO	FL 2052 ⊕	2NC+1NO
B21	Y+Y+Y slow action	FL 2136	3NC	FL 2151 ⊕	3NC	FL 2152 ⊕	3NC
B22	Y+X+X slow action	FL 2236	1NC+2NO	FL 2251 ⊕	1NC+2NO	FL 2252 ⊕	1NC+2NO
B2	Za+Za snap action	FL 236	1NO-1NC+1NO-1NC	FL 251	1NO-1NC+1NO-1NC	FL 252	1NO-1NC+1NO-1NC
Max. speed		1,5 m/s		page 13 - type 1		page 13 - type 1	
Min. force		15 Ncm		9 Ncm (25 Ncm)		9 Ncm (25 Ncm)	
Travel diagrams		page 12 - group 4		page 12 - group 4		page 12 - group 4	

FL series
metal housing

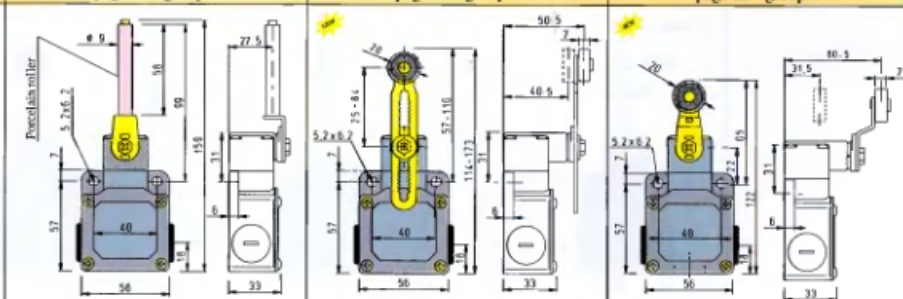

B5	Zb snap action	FL 553 ⊕	1NO+1NC	FL 556 ⊕	1NO+1NC	FL 557 ⊕	1NO+1NC
B6	Zb slow action	FL 653 ⊕	1NO+1NC	FL 656 ⊕	1NO+1NC	FL 657 ⊕	1NO+1NC
B7	Zb slow action	FL 753 ⊕	1NO+1NC Overlapped Contacts	FL 756 ⊕	1NO+1NC Overlapped Contacts	FL 757 ⊕	1NO+1NC Overlapped Contacts
B9	Y+Y slow action	FL 953 ⊕	2NC	FL 956 ⊕	2NC	FL 957 ⊕	2NC
B10	X+X slow action	FL 1053	2NO	FL 1056	2NO	FL 1057	2NO
B11	Y+Y snap action	FL 1153 ⊕	2NC	FL 1156 ⊕	2NC	FL 1157 ⊕	2NC
B14	Y+Y slow action	FL 1453 ⊕	2NC Shifted Contacts	FL 1456 ⊕	2NC Shifted Contacts	FL 1457 ⊕	2NC Shifted Contacts
B15	X+X slow action	FL 1553	2NO Shifted Contacts	FL 1556	2NO Shifted Contacts	FL 1557	2NO Shifted Contacts
B16	Y+Y slow action	/	/	FL 1656 ⊕	2NC Independent Contacts	FL 1657 ⊕	2NC Independent Contacts
B20	Y+Y+X slow action	FL 2053 ⊕	2NC+1NO	FL 2056 ⊕	2NC+1NO	FL 2057 ⊕	2NC+1NO
B21	Y+Y+Y slow action	FL 2153 ⊕	3NC	FL 2156 ⊕	3NC	FL 2157 ⊕	3NC
B22	Y+X+X slow action	FL 2253 ⊕	1NC+2NO	FL 2256 ⊕	1NC+2NO	FL 2257 ⊕	1NC+2NO
B2	Za+Za snap action	/	/	FL 256	1NO-1NC+1NO-1NC	FL 257	1NO-1NC+1NO-1NC
Max. speed		0,5 m/s		page 13 - type 1		page 13 - type 1	
Min. force		6 Ncm (25 Ncm)		15 Ncm (25 Ncm)		15 Ncm (25 Ncm)	
Travel diagrams		page 12 - group 5		page 12 - group 4		page 12 - group 4	

FL series
metal housing

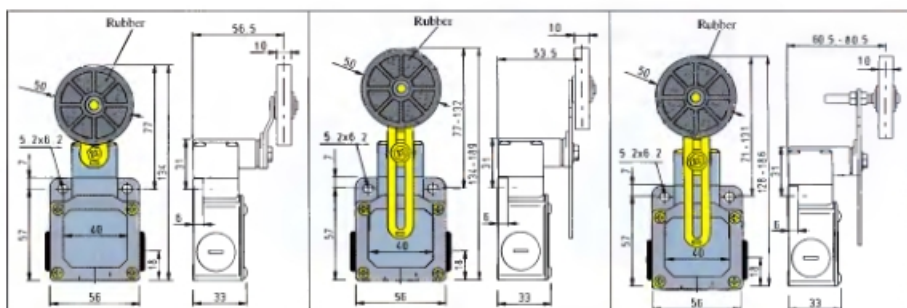

B5	Zb	snap action	FL 531-3	INO+INC	FL 535-3	INO+INC	FL 535-4	INO+INC
B6	Zb	slow action	FL 631-3	INO+INC	FL 635-3	INO+INC	FL 635-4	INO+INC
B7	Zb	slow action	FL 731-3	INO+INC Overlapped Contacts	FL 735-3	INO+INC Overlapped Contacts	FL 735-4	INO+INC Overlapped Contacts
B9	Y+Y	slow action	FL 931-3	2NC	FL 935-3	2NC	FL 935-4	2NC
B10	X+X	slow action	FL 1031-3	2NO	FL 1035-3	2NO	FL 1035-4	2NO
B11	Y+Y	snap action	FL 1131-3	2NC	FL 1135-3	2NC	FL 1135-4	2NC
B14	Y+Y	slow action	FL 1431-3	2NC Shifted Contacts	FL 1435-3	2NC Shifted Contacts	FL 1435-4	2NC Shifted Contacts
B15	X+X	slow action	FL 1531-3	2NO Shifted Contacts	FL 1535-3	2NO Shifted Contacts	FL 1535-4	2NO Shifted Contacts
B16	Y+Y	slow action	FL 1631-3	2NC Independent Contacts	FL 1635-3	2NC Independent Contacts	FL 1635-4	2NC Independent Contacts
B20	Y+Y+X	slow action	FL 2031-3	2NC+1NO	FL 2035-3	2NC+1NO	FL 2035-4	2NC+1NO
B21	Y+Y+Y	slow action	FL 2131-3	3NC	FL 2135-3	3NC	FL 2135-4	3NC
B22	Y+X+X	slow action	FL 2231-3	1NC+2NO	FL 2235-3	1NC+2NO	FL 2235-4	1NC+2NO
B2	ZaZa	snap action	FL 231-3	1NO-1NC+1NO-1NC	FL 235-3	1NO-1NC+1NO-1NC	FL 235-4	1NO-1NC+1NO-1NC
Max. speed			page 13 - type 1		page 13 - type 1		page 13 - type 1	
Min. force			15 Ncm (25 Ncm)		15 Ncm (25 Ncm)		15 Ncm (25 Ncm)	
Travel diagrams			page 12 - group 4		page 12 - group 4		page 12 - group 4	

FL series
metal housing

For rope operation
Installation accessories on page 186

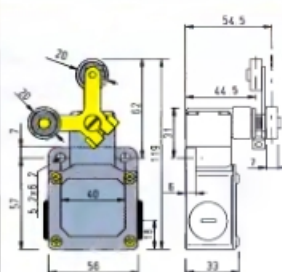
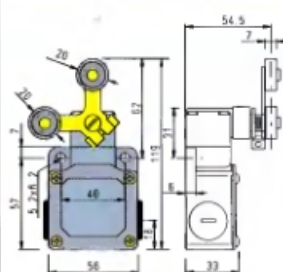
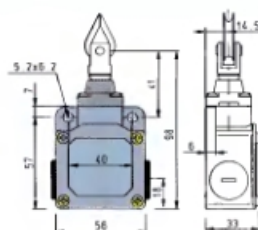

B5	Zb	snap action	FL 576	INO+INC	With two fixed positions FL 541	INO+INC	With two fixed positions FL 542	INO+INC
B6	Zb	slow action	FL 676	INO+INC	Lyra lever with single track	Lyra lever with double track	Lyra lever with double track	
B7	Zb	slow action	FL 776	INO+INC Overlapped Contacts				
B9	X+X	slow action	FL 976	2NO				
B10	Y+Y	slow action	FL 1076	2NC				
B11	X+X	snap action	FL 1176	2NO				
B14	X+X	slow action	FL 1476	2NO Shifted Contacts				
B15	Y+Y	slow action	FL 1576	2NC Shifted Contacts				
B20	Y+X+X	slow action	FL 2076	1NC+2NO				
B21	X+X+X	slow action	FL 2176	3NO				
B22	Y+Y+X	slow action	FL 2276	2NC+1NO				
B2	ZaZa	snap action	FL 276	1NO-1NC+1NO-1NC				
Max. speed			0,5 m/s		0,5 m/s with cam 30°		0,5 m/s with cam 30°	
Min. force			Starting 20 N - Ultimate 40 N		21 Ncm		21 Ncm	
Travel diagrams			page 12 - group 6					

⊕ positive opening with lever adjusted on the max. position only. See on page 39

Position switches without actuator

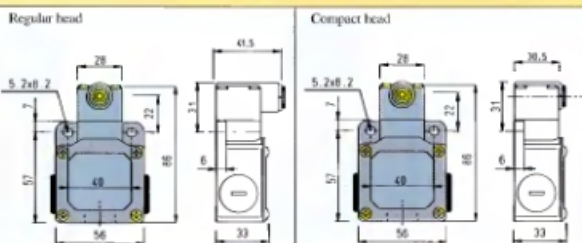

IMPORTANT:
For safety applications:
please combine only switches
and levers showing on the side
of their reference number the
symbol "⊕".
For more information about
safety applications see details
on page 231.

B5	Zb	snap action	FL 538 ⊕	INO+INC	FL 558 ⊕	INO+INC
B6	Zb	slow action	FL 638 ⊕	INO+INC	FL 658 ⊕	INO+INC
B7	Zb	slow action	FL 738 ⊕	INO+INC Overlapped Contacts	FL 758 ⊕	INO+INC Overlapped Contacts
B9	Y+Y	slow action	FL 938 ⊕	2NC	FL 958 ⊕	2NC
B10	X+X	slow action	FL 1038	2NO	FL 1058	2NO
B11	Y+Y	snap action	FL 1138 ⊕	2NC	FL 1158 ⊕	2NC
B14	Y+Y	slow action	FL 1438 ⊕	2NC Shifted Contacts	FL 1458 ⊕	2NC Shifted Contacts
B15	X+X	slow action	FL 1538	2NO Shifted Contacts	FL 1558	2NO Shifted Contacts
B16	Y+Y	slow action	FL 1638 ⊕	2NC Independent Contacts	/	/
B20	Y+Y+X	slow action	FL 2038 ⊕	2NC+1NO	FL 2058 ⊕	2NC+1NO
B21	Y+Y+Y	slow action	FL 2138 ⊕	3NC	FL 2158 ⊕	3NC
B22	Y+X+X	slow action	FL 2238 ⊕	INC+2NO	FL 2258 ⊕	INC+2NO
B2	Za+Za	snap action	FL 238	INO-INC+INO-INC	FL 258	INO-INC+INO-INC
Min. force			15 Ncm (25 Ncm)		9 Ncm (25 Ncm)	
Travel diagrams			page 12 - group 4		page 12 - group 4	

Loose actuators

IMPORTANT: These loose actuators can be used with items of series FD, FP, FL, FC only.

	With regular head only 	With regular head only 		With regular head only 	With regular head only
VF L31 ⊕ 10 pc	VF L32 ⊕ 10 pc	VF L33 ⊕ 10 pc	VF L34 ⊕ 10 pc	VF L35 ⊕* 10 pc	VF L36 ⊕ 10 pc
			With regular head only 		
VF L51 ⊕ 10 pc	VF L52 ⊕ 10 pc	VF L53 ⊕ 10 pc	VF L56 ⊕ 10 pc	VF L57 ⊕ 10 pc	

Quantities near the symbol indicate the number of pieces in each pack. Only orders for quantities multiple of the packs are accepted.

* Lever VF L35 suits to safety applications only if adjusted to its max. length, as you can see on the figure on the right:

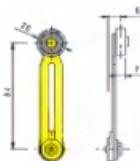

Position switches FC series



Technical data

Housing

Made of metal, coated with baked epoxy powder

One conduit entry PG 11 or M16x1,5

Protection degree: IP66

General data

Ambient temperature: from -25°C to +80°C

Max operating frequency: 3600 operations/hour

Mechanical endurance: from 10 to 20 millions of operations

Electrical data

Thermal current (Ith): 10A

Rated insulation voltage (Ui): 500 VAC 600 VDC

400 VAC for B33 - B34

Protection against short circuits: fuse 10A 500V type aM

Pollution degree: 3

Utilization categories

Alternate current: AC15 (50...60Hz)

Ue(V)	250	400	500
-------	-----	-----	-----

Ie(A)	6	3	1
-------	---	---	---

Direct current: DC13

Ue(V)	24	125	250
-------	----	-----	-----

Ie(A)	6	1.1	0.4
-------	---	-----	-----

Markings and quality marks:

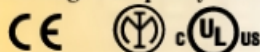

Approval type IMQ: EG608

Approval type UL: E131787

Conforms to the standards:

IEC 947-5-1, IEC 337-1, EN 60947-5-1, CEI EN 60947-5-1, CEI 17-45, CEI 17-31, IEC 204-1, EN 60204-1, CEI 44-5, EN 1088, EN 292, IEC 529, EN 60529, CEI 70-1, NFC 63-140, VDE 0660-200, VDE 0113, CENELEC EN 50013.

Approval types:

IEC 947-5-1, UL 508

Complying with the requirements requested by:

Low Voltage Directive 73/23/EEC and subsequent modifications and completions, Machinery Directive 98/37/EEC, Electromagnetic Compatibility 89/336/EEC and subsequent modifications and completions.

Positive contact opening complying with the standards:

IEC 947-5-1, EN 60947-5-1, CEI EN 60947-5-1, VDE 0660-206.

Installation for safety applications :

Use only switches with the symbol "⊞" on their sides. Safety circuit must always be connected with the **NC contacts** (normally closed contacts: 11-12 or 21-22) as stated in the **standard CEI EN 60947-5-1, encl. K, par.2**. **The switch must be actuated with the minimum positive opening travel** shown in the travels diagrams on page 12. **The switch must be actuated with the minimum positive opening force**, shown in brackets, underneath each article, near the value of the min. force. For a correct installation of these articles see examples on page 231.

How to read travel diagrams :

snap action

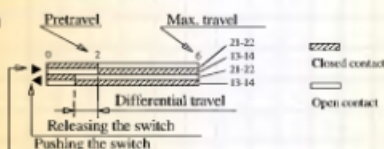

slow action

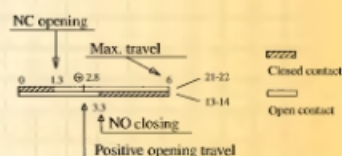

Data type approved by IMQ

- Rated insulation voltage (Ui) 500 VAC
400 VAC (for B33, B34)
- Thermal current (Ith) 10A
- Protection against short circuits fuse 10A 500V type aM
- Protection degree of the housing IP66
- MV terminals (screw clamps)
- Pollution degree 3
- Utilization category AC15
- Operation voltage (Ue) 400 VAC (50 Hz)
- Operation current (Ie) 3A
- Forms of the contact element Za, Zb, Y+Y
- Positive opening of contacts on B33, B34
- Conforms to the standards: EN60947-1, EN 60947-1 A11, EN 60947-5-1 and fundamental requirements of the Low Voltage Directive 73/23 EEC and 93/68 EEC.

Please contact our technical service for the list of our type approved products

Data type approved by UL

- Utilization categories Q300 (69VA, 125-250 VDC)
A600 (720VA, 120-600 VAC)
- Data of the housing Type 1, 4X
(indoor use only), 12, 13
- Conforms to the standard: UL 508

Please contact our technical service for the list of our type approved products

FC series
metal housing

B3	Za snap action 	FC 301 INO+INC 	FC 302 INO+INC 	FC 305 INO+INC
B33	Zb slow action 	FC 3301 INO+INC 	FC 3302 INO+INC 	FC 3305 INO+INC
B34	Y+Y slow action 	FC 3401 2NC 	FC 3402 2NC 	FC 3405 2NC
Max. speed	page 13 - type 4	page 13 - type 3	page 13 - type 3	page 13 - type 3
Min. force	6 N (20 N)	4 N (20 N)	4 N (20 N)	4 N (20 N)
FC series metal housing		<p>With external rubber gasket</p>		
B3	Za snap action 	FC 308 INO+INC 	FC 310 INO+INC 	FC 311 INO+INC
B33	Zb slow action 	FC 3308 INO+INC 	FC 3310 INO+INC 	FC 3311 INO+INC
B34	Y+Y slow action 	FC 3408 2NC 	FC 3410 2NC 	FC 3411 2NC
Max. speed	page 13 - type 4	page 13 - type 4	page 13 - type 4	page 13 - type 4
Min. force	6 N (20 N)	7 N (21 N)	6 N (20 N)	6 N (20 N)

Items with code on the green background are available in stock.

	<p>With external rubber gasket</p>		
<p>B3 Zα snap action</p>	<p>FC 315 INO+INC</p>	<p>FC 316 INO+INC</p>	<p>FC 318 INO+INC</p>
<p>B33 Zβ slow action</p>	<p>FC 3315 INO+INC</p>	<p>FC 3316 INO+INC</p>	<p>FC 3318 INO+INC</p>
<p>B34 Y+Y slow action</p>	<p>FC 3415 2NC</p>	<p>FC 3416 2NC</p>	<p>FC 3418 2NC</p>
<p>Max. speed</p>	page 13 - type 2	page 13 - type 2	page 13 - type 4
<p>Min. force</p>	7 N (21 N)	6 N (20 N)	6 N (20 N)
<p>FC series metal housing</p>			
<p>B3 Zα snap action</p>	<p>FC 320 INO+INC</p>	<p>FC 321 INO+INC</p>	<p>FC 325 INO+INC</p>
<p>B33 Zβ slow action</p>	<p>FC 3320 INO+INC</p>	<p>FC 3321 INO+INC</p>	<p>FC 3325 INO+INC</p>
<p>B34 Y+Y slow action</p>	<p>FC 3420 2NC</p>	<p>FC 3421 2NC</p>	<p>FC 3425 2NC</p>
<p>Max. speed</p>	1 m/s	1 m/s	1 m/s
<p>Min. force</p>	7 Ncm	6 Ncm	10 Ncm

FC series
metal housing

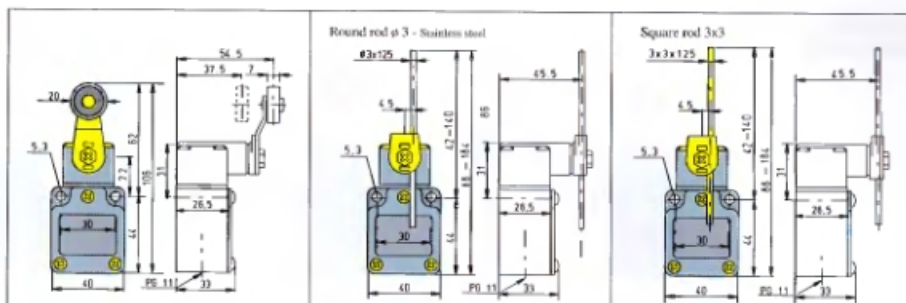



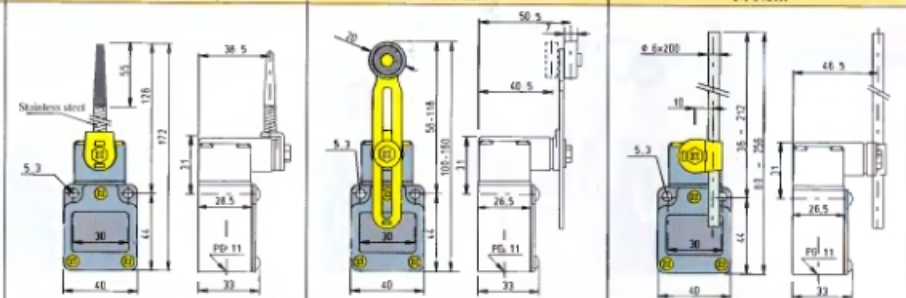

B3 Za snap action 	FC 331 INO+INC 	FC 332 INO+INC 	FC 333 INO+INC 	
	B33 Zb slow action 	FC 3331 ⊖ INO+INC 	FC 3332 INO+INC 	FC 3333 INO+INC
	B34 Y+Y slow action 	FC 3431 ⊕ 2NC 	FC 3432 2NC 	FC 3433 2NC
Max. speed Min. force	page 13 - type 1 14 Ncm (25 Ncm)		1,5 m/s 14 Ncm	
		1,5 m/s 14 Ncm		

FC series
metal housing

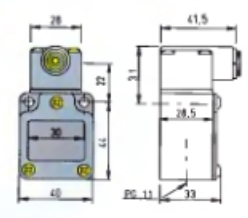
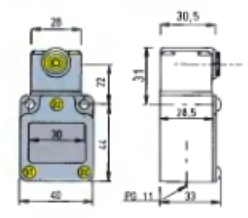

B3 Za snap action 	FC 334 INO+INC 	FC 335 INO+INC 	FC 336 INO+INC 	
	B33 Zb slow action 	FC 3334 INO+INC 	FC 3335 ⊕ INO+INC 	FC 3336 INO+INC
	B34 Y+Y slow action 	FC 3434 2NC 	FC 3435 ⊕ 2NC 	FC 3436 2NC
Max. speed Min. force	1 m/s 14 Ncm		page 13 - type 1 14 Ncm (25 Ncm)	
		1,5 m/s 14 Ncm		

⊕ positive opening with lever adjusted on the max. position only. See on page 46

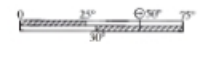
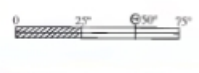
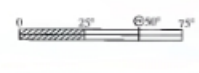
Position switches without actuator		
	Regular head	Compact head
		
B3	FC 338 1NO+1NC 	FC 358 1NO+1NC 
B33	FC 3338 1NO+1NC 	FC 3358 1NO+1NC 
B34	FC 3438 2NC 	FC 3458 2NC 
Min. force	14 Ncm (25 Ncm)	8 Ncm (25 Ncm)

IMPORTANT:

For safety applications: please combine only switches and levers showing on the side of their reference number the symbol "⊕". For more information about safety applications see details on page 231.

Loose actuators

IMPORTANT: These loose actuators can be used with items of series FD, FP, FL, FC only.

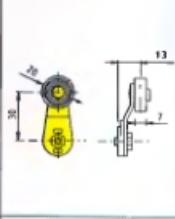
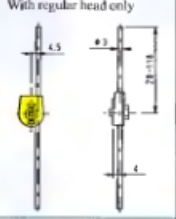
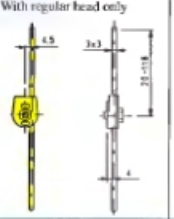
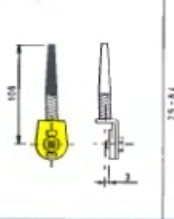
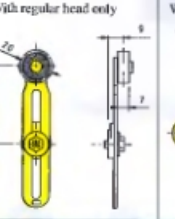
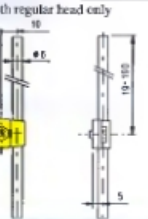
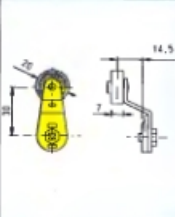
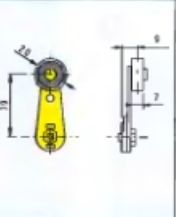
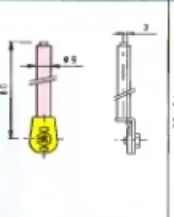
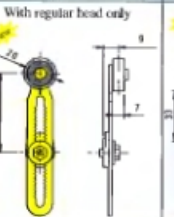
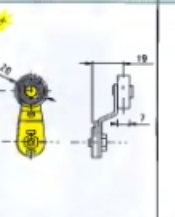
	With regular head only 	With regular head only 		With regular head only 	With regular head only 
VF L31 ⊕ 10 pc	VF L32 ⊕ 10 pc	VF L33 ⊕ 10 pc	VF L34 ⊕ 10 pc	VF L35 ⊕* 10 pc	VF L36 ⊕ 10 pc
			With regular head only 		
VF L51 ⊕ 10 pc	VF L52 ⊕ 10 pc	VF L53 ⊕ 10 pc	VF L56 ⊕ 10 pc	VF L57 ⊕ 10 pc	

Quantities near the symbol  indicate the number of pieces in each pack. Only orders for quantities multiple of the packs are accepted.

* Lever VF L35 suits to safety applications only if adjusted to its max. length, as you can see on the figure on the right:

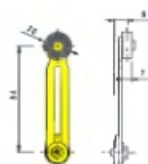

General data of the light series **FR-FM-FX-FZ-FK**

Orientable heads

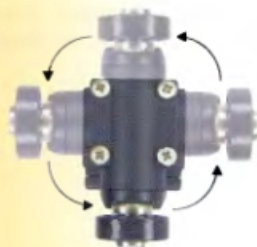

Taking out the four fastening screws, it is possible in every switch to rotate its head with 90° increments.



Adjustable levers

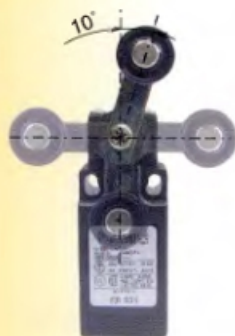

In the switches with revolving lever it is possible to adjust the lever with 10° increments for all the 360°. The positive movement transmission is always guaranteed thanks to the particular geometrical coupling shape between the lever and the revolving shaft (photo below), as the German standard BG-GS-ET-15 prescribes for safety applications.



Screws driving torques



Tighten all the fastening screws (cover **1**, head **2** and lever **3**) with a driving torques 0,7 ... 0,9 Nm. Tighten the protection plugs **4** with a driving torques 1,2 ... 2,0 Nm.



Tighten the fastening screws **7** of the contact blocks with a driving torques 0,6 ... 0,8 Nm.

Contact block with snap action: B2 - B3 - B5 - B11

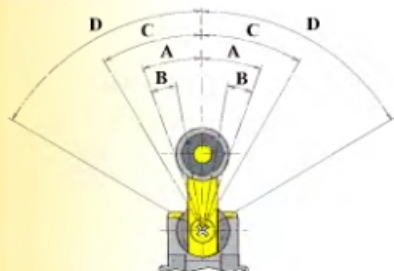

A	NC opening and NO closing
B	Differential travel
C	Positive opening travel
D	Max. travel

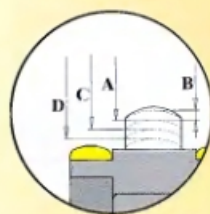
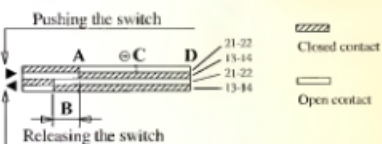

Contact block with slow action: B6 - B7 - B9 - B10 - B14 - B15 - B20 - B21 - B22

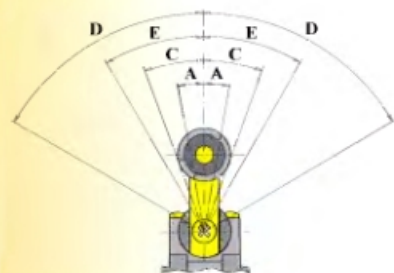

A	NC opening
C	Positive opening travel
E	NO closing
D	Max. travel

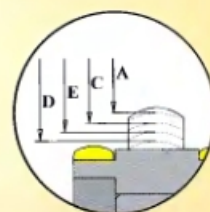
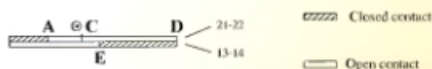

Travels diagrams of the series FR - FM - FX - FZ (All measures in the diagrams are in mm or degrees).

Contact blocks	Heads groups	Group 1	Group 2	Group 3	Group 4	Group 5	Group 6
B5 1NO+1NC	13 21 14 22	0 1 0.2 4	0 2.8 0.43 8	0 5 0.15 13	0 15°	0 30° 0.48 7°	0 32° 0.41 7°
B6 1NO+1NC	12 21 14 22	0 1.2 0.28 4	0 1.7 0.4 8	0 3 0.1 13	/	0 22° 0.41 7°	0 30° 0.41 7°
B7 1NO+1NC	13 21 14 22	0 1.7 0.42 4	0 2.3 0.4 8	0 6.5 0.13 13	/	0 43° 0.48 7°	0 38° 0.38 7°
B9 2NC	11 21 12 22	0 2.7 0.42 4	0 3.4 0.6 8	0 6.5 0.13 13	/	0 43° 0.48 7°	0 38° 0.38 7°
B10 2NO	13 23 14 24	0 1.3 0.2 4	0 1.7 0.4 8	0 3 0.1 13	0 15°	0 32° 0.41 7°	0 30° 0.41 7°
B11 2NC	11 21 12 22	0 0.8 0.4 4	0 2.5 0.43 8	0 5 0.1 13	/	0 30° 0.38 7°	/
B14 2NC	13 21 12 22	0 1.7 0.42 4	0 2.4 0.4 8	0 6.5 0.1 13	/	0 43° 0.48 7°	0 38° 0.38 7°
B15 2NO	13 23 14 24	0 1.3 0.2 4	0 1.7 0.4 8	0 3 0.1 13	/	0 32° 0.41 7°	0 30° 0.41 7°
B16 2NC	11 21 12 22	/	/	/	/	0 30° 0.38 7°	/
B20 2NC+1NO	11 21 33 12 22 34	0 1.6 0.1 4	0 2 0.45 8	0 3.6 0.1 13	0 30°	0 22° 0.41 7°	0 30° 0.41 7°
B21 3NC	11 21 31 12 22 32	0 1.6 0.1 4	0 2 0.43 8	0 3.6 0.1 13	0 30°	0 31° 0.42 7°	0 30° 0.41 7°
B22 1NC+2NO	11 23 33 12 24 34	0 1.6 0.1 4	0 2 0.43 8	0 3.6 0.1 13	0 30°	0 22° 0.41 7°	0 30° 0.41 7°
B2 1NO-1NC+1NO-1NC	13 21 43 31 14 22 44 32	0 1 0.2 4	0 1.2 0.4 8	0 2.6 0.1 13	0 15°	0 30° 0.41 7°	/

General data of the light series **FR-FM-FX-FZ-FK**

Maximum actuation speed

Type 1: lever with roller

φ	V_{\max} (m/s)
15°	2,5
30°	1,5
45°	1
60°	0,75

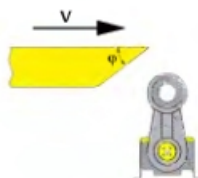

Type 2: plunger with roller.

φ	V_{\max} (m/s)
15°	0,6
30°	0,3

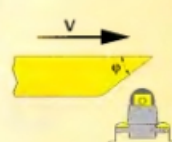

Type 3: lever with roller :

1) with side action

2) with vertical action

Type 4: plunger

φ	V_{\max} (m/s)
15°	1,5
30°	1

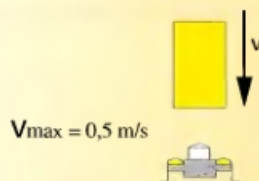
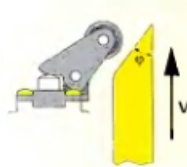
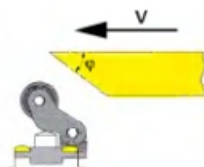

Maximum cross section of the conductors (flexible lead wire) in the contact blocks

Contact blocks B2, B3, B20, B21, B22, B33, B34	Contact blocks B5, B6, B7, B9, B10, B11, B14, B15, B16
2 x 1,5 mm ² (2 x AWG 16)	2 x 2,5 mm ² (2 x AWG 14)

Code of the article: how to read the code

Please contact our sales office, since no all combinations are available.

FR 501 - M2

Suffixes

- 1 with metal roller
- 2 with plastic \varnothing 35 roller
- M1 threaded housing M16x1,5
- M2 threaded housing M20x1,5

Kind of housing

- FR** polymer housing complying with EN 50047
- FM** metal housing complying with EN 50047
- FX** polymer housing
- FZ** metal housing
- FK** polymer housing

Kind of contact block

- B5** INC+INO snap action
- B6** INC+INO slow action
- B7** INC+INO slow action
-
- 13 different contact blocks quoted with the letter B can be used

Kind of actuator

- 01** with short piston
- 02** with lever with roller
- 05** with roller lever
-
- 30 different heads are present in the position switches

ACCESSORIES

Light indicator

A light indicator is used in order to visualize a change of state of the electric contacts inside the switch. It can be installed only in the series FL,FX,FZ or FS by screwing it on one of the conduit entries not used for electric cables and it can have many different functions :

Combined with a rope operated switch (for instance FL 678) it can indicate whether the switch has been actuated.

Combined with a key safety switch (for instance FL 693) it indicates whether the protection has been closed correctly or not.

Combined with a safety switch with solenoid (for instance FS 2096D024) it can indicate whether the protection is locked or unlocked.

Combined with any switch of the series FL, FX or FZ can be used to adjust the actuator that press the switch.

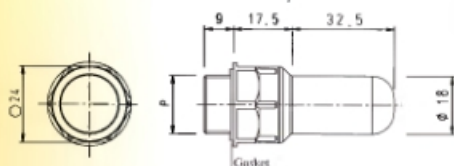

- Max operating voltage (Ui) 250 VAC/DC
- Max power of the lamp 3W
- Protection degree IP66
- Lamp type BA9
- Max. cross section of the cable 1,5 mm²
- Ambient temperature -25 °C ... +40 °C
- Driving torque 3 ... 4 Nm



5 pc. packs



VF ILI024GP

Lamp		Threaded couplings	
Kind of lamp		P	PG 13,5
I	Incandescence	M	M20 x 1,5
Supply voltage		Lamp color	
024	24 VAC/DC ± 10%	G	Yellow
110	110 VAC/DC ± 10%		
220	220 VAC/DC ± 10%		

Connectors

Connectors are used where a very short machine down time is critical (for example in big plants). The switch with connector can be replaced with an identical one very quickly, avoiding the possibility of incorrect wiring.

These standard male M12 connectors are ready for the installation on the switches. Their wires have the right length for the connection to the contact blocks and are provided with seamed rods. On request they can be delivered already wired to the switches.

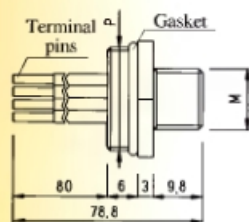

- Rated voltage (Ui) 250 VAC / 300 VDC (4 poles)
30 VAC / 36 VDC (5 poles)
- Rated current (Ith) 3A
- Protection degree IP68 (1 bar)
- Ambient temperature -25...+80 °C
- Number of poles 4 or 5
- Driving torque 1 ÷ 1,5 Nm



10 pc. packs



VF CNM5PM

Please contact our sales office since no all combination is available

Connector		Kind of coupling (M)	
Material		M	M12 x 1
M	Metal	Thread of the connector (P)	
P	Plastic	P	PG 13,5
Number of poles		M	M20 x 1,5
5	5 poles		
4	4 poles		

General data of the light series FR-FM-FX-FZ-FK

Cable glands

If the operating environment of the switch requires a protection degree against water or dust, the use of an adequate cable gland is recommended in order to guarantee a sufficient protection degree to the switch.

The IP protection degree of the cable gland shall be equal or higher than the IP protection degree of the switch.

Data

- Material of body and ring nut: Polymer glass-reinforced resin
- Protection degree : IP66
- Driving torque : 3 ... 4 Nm

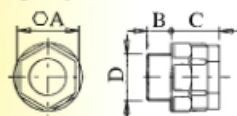

100 pc. packs



Article	Description	OA	B	C	D
VF PG13,5	PG 13,5 cable gland for multipolar cables from Ø 9 to Ø 12 mm.	24	9	19	PG 13,5
VF PG13,5/6	PG 13,5 cable gland for multipolar cables from Ø 6 to Ø 9 mm.	24	9	19	PG 13,5
VF PG13,5/3	PG 13,5 cable gland for multipolar cables from Ø 3 to Ø 6 mm.	24	9	19	PG 13,5
VF PG11	PG 11 cable gland for multipolar cables from Ø 6 to Ø 9 mm.	22	7	16,5	PG 11
VF PG11/3	PG 11 cable gland for multipolar cables from Ø 3 to Ø 6 mm.	22	7	16,5	PG 11
VF PM20	M20x1,5 cable gland for multipolar cables from Ø 9 to Ø 12 mm.	24	9	19	M20x1,5
VF PM20/6	M20x1,5 cable gland for multipolar cables from Ø 6 to Ø 9 mm.	24	9	19	M20x1,5
VF PM20/3	M20x1,5 cable gland for multipolar cables from Ø 3 to Ø 6 mm.	24	9	19	M20x1,5
VF PM16	M16x1,5 cable gland for multipolar cables from Ø 6 to Ø 9 mm.	22	7	16,5	M16x1,5

Thread adapters

With these adapters it is possible to offer to the customers the same product with different threaded cable entries, while only having to stock a single product and many kinds of adapters.

Data

- Body material : Polymer glass-reinforced resin
- Driving torque : 3 ... 4 Nm

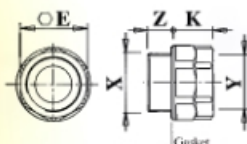

100 pc. packs



Article	Description	X	Y	Z	K	OE
VF ADPG13-PG11	Adapter from PG 13,5 to PG 11	PG 13,5	PG 11	9	12	22
VF ADPG13-M20	Adapter from PG 13,5 to M20x1,5	PG 13,5	M20x1,5	9	14	24
VF ADPG13-1/2NPT	Adapter from PG 13,5 to 1/2 NPT	PG 13,5	1/2 NPT	9	14	24
VF ADPG11-1/2NPT	Adapter from PG 11 to 1/2 NPT	PG 11	1/2 NPT	7	14	24
VF ADPG11-PG13	Adapter from PG 11 to PG 13,5	PG 11	PG 13,5	7	14	24

Protection plugs

Data

- Body material : Polymer glass-reinforced resin
- Protection degree: IP66
- Driving torque: 1,2 ... 2 Nm

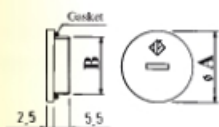

100 pc. packs

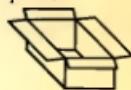

Article	Description	A	B
VF PTG13,5	Protection plug PG13,5	25	PG 13,5
VF PTM20	Protection plug M20x1,5	25	M20x1,5
VF PTG11	Protection plug PG11	23	PG 11
VF PTM16	Protection plug M16x1,5	23	M16x1,5

On request switches in special versions

- Versions with pre-wired connector made of plastic or metal.
- Special versions for -40°C use.
- Special versions with reduced pretravel.
- Versions with electronic contact block, see on page 137 .
- Some articles are available with some metallic or stainless steel parts.
- For the articles with head 31, 35 and 52 you may require plastic rollers Ø 35 mm or rubber roller Ø 40 mm and Ø 50 mm.
- Special versions with reduced actuating force.
- Special versions with head oriented to the left, to the right or to the rear.
- Custom-made special versions.

➔ For further information, please contact our technical service (see on page IV).

Notes

Position switches FR series



Technical data

Housing

Made of polymer glass-reinforced, self-extinguishing, shock proof thermoplastic resin and with double insulation. 

One conduit entry PG 13,5 or M20x1,5.

Protection degree: IP65

General data

Ambient temperature: from -25°C to +80°C

Max. operating frequency: 3600 operations/hour

Mechanical endurance: 20 millions of operations

Electrical data

Thermal current (Ith): 10A

Rated insulation voltage (Ui): 500 VAC 600 VDC

400 VAC per B20 - B21 - B22

Protection against short circuits: fuse 10A 500V type aM

Pollution degree: 3

Conforms to the standards:

IEC 947-5-1, IEC 337-1, EN 60947-5-1, CEI EN 60947-5-1, CEI 17-45, EN 50047, CEI 17-33, IEC 204-1, EN 60204-1, CEI 44-5, EN 1088, EN 292, IEC 529, EN 60529, CEI 70-1, NCF 63-140, VDE 0660-200, VDE 0113, CENELEC EN 50013.

Approval types:

IEC 947-5-1, UL 508, CSA C22-2 nr.14.

Utilization category

Alternate current: AC15 (50...60Hz)

Ue(V) 250 400 500

Ie(A) 6 3 1

Direct current: DC13

Ue(V) 24 125 250

Ie(A) 6 1.1 0.4

Markings and quality marks:

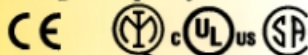

Approval type IMQ: EG610

Approval type UL: E131787

Approval type CSA: LR 93682-1

Complying with the requirements requested by:

Low Voltage Directive 73/23/EEC and subsequent modifications and completions, Machinery Directive 98/37/EEC, Electromagnetic Compatibility 89/336/EEC and subsequent modifications and completions.

Positive contact opening complying with the standards:

IEC 947-5-1, EN 60947-5-1, CEI EN 60947-5-1, VDE 0660-206.

Installation for safety applications :

Use only switches with the symbol "  " on their sides. Safety circuit must always be connected with the **NC contacts** (normally closed contacts: 11-12, 21-22 or 31-32) as stated in the **standard CEI EN 60947-5-1, encl. K, par. 2**. **The switch must be actuated with the minimum positive opening travel** shown in the travels diagrams on page 48. **The switch must be actuated with the minimum positive opening force**, shown in brackets, underneath each article, near the value of the min. force. For a correct installation of these articles see examples on page 231.

Data type approved by IMQ

- Rated insulation voltage (Ui) 500 VAC
400 VAC (for B20, B21, B22, B33, B34)
- Thermal current (Ith) 10A
- Protection against short circuits fuse 10A 500V type aM
- Protection degree of the housing IP65
- MV terminals (screw clamps)
- Pollution degree 3
- Utilization category AC15
- Operation voltage (Ue) 400 VAC (50 Hz)
- Operation current (Ie) 3A
- Forms of the contact element Za, Zb, Za+Za, Y+Y, X+X, Y+Y+X, Y+Y+Y, Y+X+X
- Positive opening of contacts on B5, B6, B7, B9, B11, B14, B16, B20, B21, B22, B33, B34
- Conforms to the standards: EN60947-1, EN 60947-1 A11, EN 60947-5-1 and fundamental requirements of the Low Voltage Directive 73/23 EEC and 93/68 EEC.

Please contact our technical service for the list of our type approved products

Data type approved by UL

- Utilization categories Q300 (69VA, 125-250 VDC)
A600 (720VA, 120-600 VAC)
- Data of the housing Type 1, 4X
(indoor use only), 12, 13
- Conforms to the standard: UL 508

Please contact our technical service for the list of our type approved products

Data type approved by CSA

- Utilization categories Q300 (69VA, 125-250 VDC)
A600 (720VA, 120-600 VAC)
- Data of the housing Type 1, 4X
(indoor use only), 12, 13
- Conforms to the standard: CSA C22-2 nr.14

Please contact our technical service for the list of our type approved products

Series FR
polymer housing

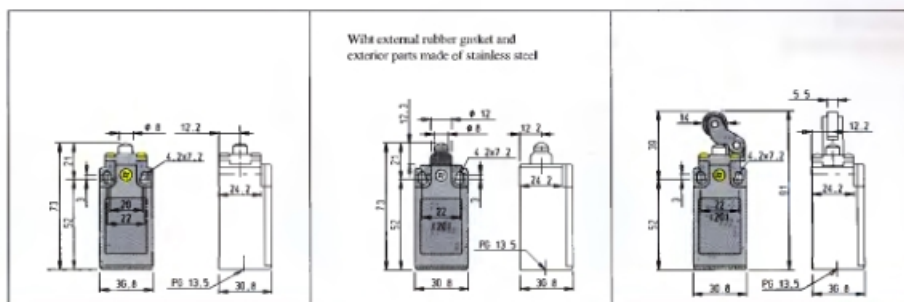

With external rubber gasket and exterior parts made of stainless steel

B5	Zb snap action	FR 501 ⊕ INO+INC	FR 5A1 ⊕ INO+INC	FR 502 ⊕ INO+INC
B6	Zb slow action	FR 601 ⊕ INO+INC	FR 6A1 ⊕ INO+INC	FR 602 ⊕ INO+INC
B7	Zb slow action	FR 701 ⊕ INO+INC Overlapped Contacts	FR 7A1 ⊕ INO+INC Overlapped Contacts	FR 702 ⊕ INO+INC Overlapped Contacts
B9	Y+Y slow action	FR 901 ⊕ 2NC	FR 9A1 ⊕ 2NC	FR 902 ⊕ 2NC
B10	X+X slow action	FR 1001 2NO	FR 10A1 2NO	FR 1002 2NO
B11	Y+Y snap action	FR 1101 ⊕ 2NC	FR 11A1 ⊕ 2NC	FR 1102 ⊕ 2NC
B14	Y+Y slow action	FR 1401 ⊕ 2NC Shifted Contacts	FR 14A1 ⊕ 2NC Shifted Contacts	FR 1402 ⊕ 2NC Shifted Contacts
B15	X+X slow action	FR 1501 2NO Shifted Contacts	FR 15A1 2NO Shifted Contacts	FR 1502 2NO Shifted Contacts
B20	Y+Y+X slow action	FR 2001 ⊕ 2NC+1NO	FR 20A1 ⊕ 2NC+1NO	FR 2002 ⊕ 2NC+1NO
B21	Y+Y+Y slow action	FR 2101 ⊕ 3NC	FR 21A1 ⊕ 3NC	FR 2102 ⊕ 3NC
B22	Y+X+X slow action	FR 2201 ⊕ 1NC+2NO	FR 22A1 ⊕ 1NC+2NO	FR 2202 ⊕ 1NC+2NO
B2	Za+Za snap action	FR 201 1NO-1NC+1NO-1NC	/	FR 202 1NO-1NC+1NO-1NC
Max. speed		page 49 - type 4	page 49 - type 4	page 49 - type 3
Min. force		8 N (20 N)	6 N (16 N)	6 N (16 N)
Travel diagrams		page 48 - group 1	page 48 - group 1	page 48 - group 2

Series FR
polymer housing

With external rubber gasket and exterior parts made of stainless steel

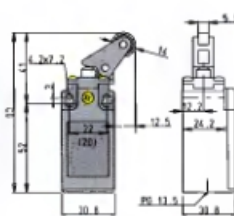
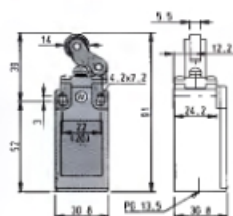

With external rubber gasket and exterior parts made of stainless steel

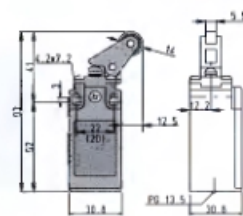

B5	Zb snap action	FR 5A2 ⊕ INO+INC	FR 505 ⊕ INO+INC	FR 5A5 ⊕ INO+INC
B6	Zb slow action	FR 6A2 ⊕ INO+INC	FR 605 ⊕ INO+INC	FR 6A5 ⊕ INO+INC
B7	Zb slow action	FR 7A2 ⊕ INO+INC Overlapped Contacts	FR 705 ⊕ INO+INC Overlapped Contacts	FR 7A5 ⊕ INO+INC Overlapped Contacts
B9	Y+Y slow action	FR 9A2 ⊕ 2NC	FR 905 ⊕ 2NC	FR 9A5 ⊕ 2NC
B10	X+X slow action	FR 10A2 2NO	FR 1005 2NO	FR 10A5 2NO
B11	Y+Y snap action	FR 11A2 ⊕ 2NC	FR 1105 ⊕ 2NC	FR 11A5 ⊕ 2NC
B14	Y+Y slow action	FR 14A2 ⊕ 2NC Shifted Contacts	FR 1405 ⊕ 2NC Shifted Contacts	FR 14A5 ⊕ 2NC Shifted Contacts
B15	X+X slow action	FR 15A2 2NO Shifted Contacts	FR 1505 2NO Shifted Contacts	FR 15A5 2NO Shifted Contacts
B20	Y+Y+X slow action	FR 20A2 ⊕ 2NC+1NO	FR 2005 ⊕ 2NC+1NO	FR 20A5 ⊕ 2NC+1NO
B21	Y+Y+Y slow action	FR 21A2 ⊕ 3NC	FR 2105 ⊕ 3NC	FR 21A5 ⊕ 3NC
B22	Y+X+X slow action	FR 22A2 ⊕ 1NC+2NO	FR 2205 ⊕ 1NC+2NO	FR 22A5 ⊕ 1NC+2NO
B2	Za+Za snap action	/	FR 205 1NO-1NC+1NO-1NC	/
Max. speed		page 49 - type 3	page 49 - type 3	page 49 - type 3
Min. force		4,3 N (15 N)	6 N (18 N)	4,3 N (15 N)
Travel diagrams		page 48 - group 2	page 48 - group 2	page 48 - group 2

Items with code on the green background are available in stock.

Series FR
polymer housing

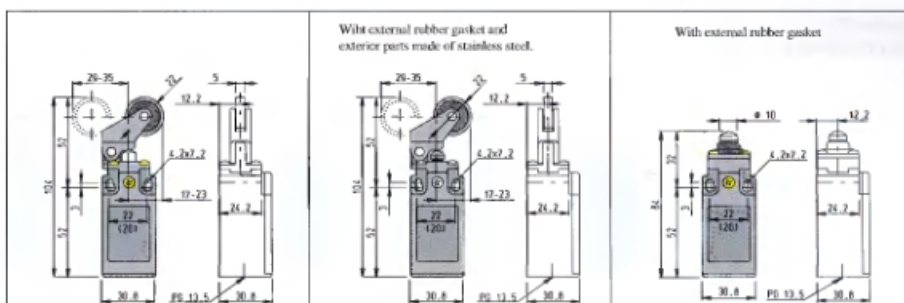

B5	Zb	snap action	FR 507	INO+INC	FR 5A7	INO+INC	FR 508	INO+INC
B6	Zb	slow action	FR 607	INO+INC	FR 6A7	INO+INC	FR 608	INO+INC
B7	Zb	slow action	FR 707	INO+INC Overlapped Contacts	FR 7A7	INO+INC Overlapped Contacts	FR 708	INO+INC Overlapped Contacts
B9	Y+Y	slow action	FR 907	2NC	FR 9A7	2NC	FR 908	2NC
B10	X+X	slow action	FR 1007	2NO	FR 10A7	2NO	FR 1008	2NO
B11	Y+Y	snap action	FR 1107	2NC	FR 11A7	2NC	FR 1108	2NC
B14	Y+Y	slow action	FR 1407	2NC Shifted Contacts	FR 14A7	2NC Shifted Contacts	FR 1408	2NC Shifted Contacts
B15	X+X	slow action	FR 1507	2NO Shifted Contacts	FR 15A7	2NO Shifted Contacts	FR 1508	2NO Shifted Contacts
B20	Y+Y+X	slow action	FR 2007	2NC+1NO	FR 20A7	2NC+1NO	FR 2008	2NC+1NO
B21	Y+Y+Y	slow action	FR 2107	3NC	FR 21A7	3NC	FR 2108	3NC
B22	Y+X+X	slow action	FR 2207	1NC+2NO	FR 22A7	1NC+2NO	FR 2208	1NC+2NO
B2	Za+Za	snap action	FR 207	1NO-1NC+1NO-1NC	/		FR 208	1NO-1NC+1NO-1NC
Max. speed			page 49 - type 3		page 49 - type 3		page 49 - type 4	
Min. force			4 N (14 N)		3 N (15 N)		8 N (18 N)	
Travel diagrams			page 48 - group 3		page 48 - group 3		page 48 - group 1	

Series FR
polymer housing

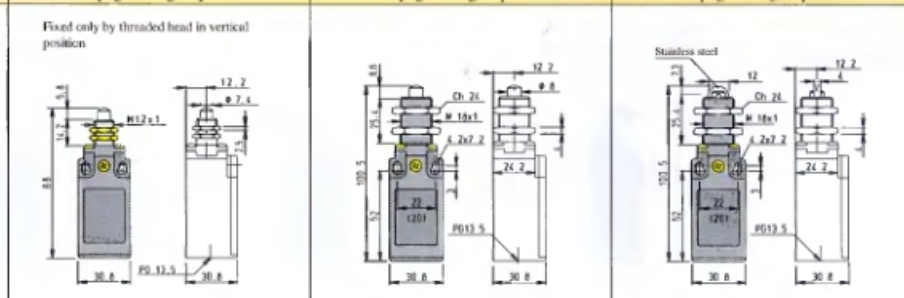

B5	Zb	snap action	FR 510	INO+INC	FR 512	INO+INC	FR 513	INO+INC
B6	Zb	slow action	FR 610	INO+INC	FR 612	INO+INC	FR 613	INO+INC
B7	Zb	slow action	FR 710	INO+INC Overlapped Contacts	FR 712	INO+INC Overlapped Contacts	FR 713	INO+INC Overlapped Contacts
B9	Y+Y	slow action	FR 910	2NC	FR 912	2NC	FR 913	2NC
B10	X+X	slow action	FR 1010	2NO	FR 1012	2NO	FR 1013	2NO
B11	Y+Y	snap action	FR 1110	2NC	FR 1112	2NC	FR 1113	2NC
B14	Y+Y	slow action	FR 1410	2NC Shifted Contacts	FR 1412	2NC Shifted Contacts	FR 1413	2NC Shifted Contacts
B15	X+X	slow action	FR 1510	2NO Shifted Contacts	FR 1512	2NO Shifted Contacts	FR 1513	2NO Shifted Contacts
B20	Y+Y+X	slow action	FR 2010	2NC+1NO	FR 2012	2NC+1NO	FR 2013	2NC+1NO
B21	Y+Y+Y	slow action	FR 2110	3NC	FR 2112	3NC	FR 2113	3NC
B22	Y+X+X	slow action	FR 2210	1NC+2NO	FR 2212	1NC+2NO	FR 2213	1NC+2NO
B2	Za+Za	snap action	FR 210	1NO-1NC+1NO-1NC	FR 212	1NO-1NC+1NO-1NC	FR 213	1NO-1NC+1NO-1NC
Max. speed			page 49 - type 4		page 49 - type 4		page 49 - type 2	
Min. force			8 N (25 N)		8 N (25 N)		8 N (25 N)	
Travel diagrams			page 48 - group 1		page 48 - group 1		page 48 - group 1	

Series FR
polymer housing

On request with stainless steel roller $\phi 12$

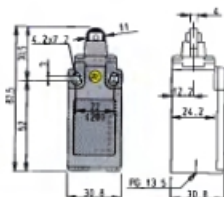

Fixed only by threaded head in vertical position

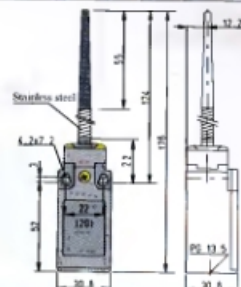
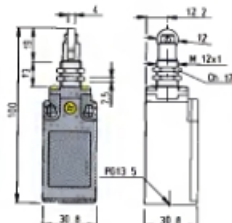

B5 Zb snap action	FR 515 \oplus INO+INC	FR 517 \oplus INO+INC	FR 520 \oplus INO+INC
B6 Zb slow action	FR 615 \oplus INO+INC	FR 617 \oplus INO+INC	/
B7 Zb slow action	FR 715 \oplus INO+INC Overlapped Contacts	FR 717 \oplus INO+INC Overlapped Contacts	/
B9 Y+Y slow action	FR 915 \oplus 2NC	FR 917 \oplus 2NC	/
B10 X+X slow action	FR 1015 2NO	FR 1017 2NO	FR 1020 2NO
B11 Y+Y snap action	FR 1115 \oplus 2NC	FR 1117 \oplus 2NC	/
B14 Y+Y slow action	FR 1415 \oplus 2NC Shifted Contacts	FR 1417 \oplus 2NC Shifted Contacts	/
B15 X+X slow action	FR 1515 2NO Shifted Contacts	FR 1517 2NO Shifted Contacts	/
B20 Y+Y+X slow action	FR 2015 \oplus 2NC+1NO	FR 2017 \oplus 2NC+1NO	FR 2020 2NC+1NO
B21 Y+Y+Y slow action	FR 2115 \oplus 3NC	FR 2117 \oplus 3NC	FR 2120 3NC
B22 Y+X+X slow action	FR 2215 \oplus 1NC+2NO	FR 2217 \oplus 1NC+2NO	FR 2220 1NC+2NO
B2 Za+Za snap action	FR 215 1NO-1NC+1NO-1NC	FR 217 1NO-1NC+1NO-1NC	FR 220 1NO-1NC+1NO-1NC
Max. speed	page 49 - type 2		1 m/s
Min. force	8 N (18 N)		5,6 Ncm
Travel diagrams	page 48 - group 1		page 48 - group 4

Series FR
polymer housing

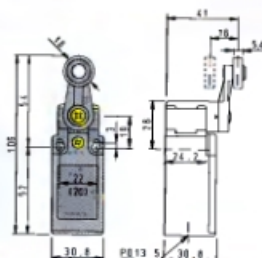
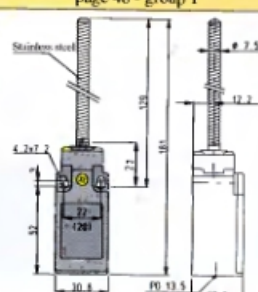
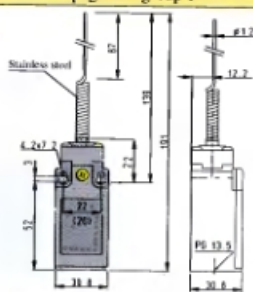

B5 Zb snap action	FR 521 INO+INC	FR 525 INO+INC	FR 530 \oplus INO+INC
B6 Zb slow action	/	/	FR 630 \oplus INO+INC
B7 Zb slow action	/	/	FR 730 \oplus INO+INC Overlapped Contacts
B9 Y+Y slow action	/	/	FR 930 \oplus 2NC
B10 X+X slow action	FR 1021 2NO	FR 1025 2NO	FR 1030 2NO
B11 Y+Y snap action	/	/	FR 1130 \oplus 2NC
B14 Y+Y slow action	/	/	FR 1430 \oplus 2NC Shifted Contacts
B15 X+X slow action	/	/	FR 1530 2NO Shifted Contacts
B16 Y+Y slow action	/	/	FR 1630 \oplus 2NC Independent Contacts
B20 Y+Y+X slow action	FR 2021 2NC+1NO	FR 2025 2NC+1NO	FR 2030 \oplus 2NC+1NO
B21 Y+Y+Y slow action	FR 2121 3NC	FR 2125 3NC	FR 2130 \oplus 3NC
B22 Y+X+X slow action	FR 2221 1NC+2NO	FR 2225 1NC+2NO	FR 2230 \oplus 1NC+2NO
B2 Za+Za snap action	FR 221 1NO-1NC+1NO-1NC	FR 225 1NO-1NC+1NO-1NC	FR 230 1NO-1NC+1NO-1NC
Max. speed	1 m/s		page 49 - type 1
Min. force	3,9 Ncm		9,8 Ncm (15 Ncm)
Travel diagrams	page 48 - group 4		page 48 - group 5

Series FR
polymer housing

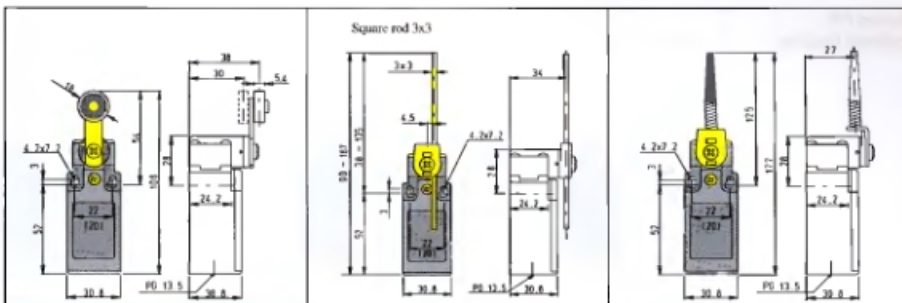

B5	Zb	snap action	FR 531 ⊕ INO+INC	FR 533	INO+INC	FR 534	INO+INC
B6	Zb	slow action	FR 631 ⊕ INO+INC	FR 633	INO+INC	FR 634	INO+INC
B7	Zb	slow action	FR 731 ⊕ INO+INC Overlapped Contacts	FR 733	INO+INC Overlapped Contacts	FR 734	INO+INC Overlapped Contacts
B9	Y+Y	slow action	FR 931 ⊕ 2NC	FR 933	2NC	FR 934	2NC
B10	X+X	slow action	FR 1031 2NO	FR 1033	2NO	FR 1034	2NO
B11	Y+Y	snap action	FR 1131 ⊕ 2NC	FR 1133	2NC	FR 1134	2NC
B14	Y+Y	slow action	FR 1431 ⊕ 2NC Shifted Contacts	FR 1433	2NC Shifted Contacts	FR 1434	2NC Shifted Contacts
B15	X+X	slow action	FR 1531 2NO Shifted Contacts	FR 1533	2NO Shifted Contacts	FR 1534	2NO Shifted Contacts
B16	Y+Y	slow action	FR 1631 ⊕ 2NC Independent Contacts	FR 1633	2NC Independent Contacts	FR 1634	2NC Independent Contacts
B20	Y+Y+X	slow action	FR 2031 ⊕ 2NC+INO	FR 2033	2NC+INO	FR 2034	2NC+INO
B21	Y+Y+Y	slow action	FR 2131 ⊕ 3NC	FR 2133	3NC	FR 2134	3NC
B22	Y+X+X	slow action	FR 2231 ⊕ INC+2NO	FR 2233	INC+2NO	FR 2234	INC+2NO
B2	Za+Za	snap action	FR 231 INO-INC+INO-INC	FR 233	INO-INC+INO-INC	FR 234	INO-INC+INO-INC
Max. speed	page 49 - type 1			1,5 m/s		1,5 m/s	
Min. force	9,8 Ncm (15 Ncm)			9,8 Ncm		9,8 Ncm	
Travel diagrams	page 48 - group 5			page 48 - group 5		page 48 - group 5	

Series FR
polymer housing

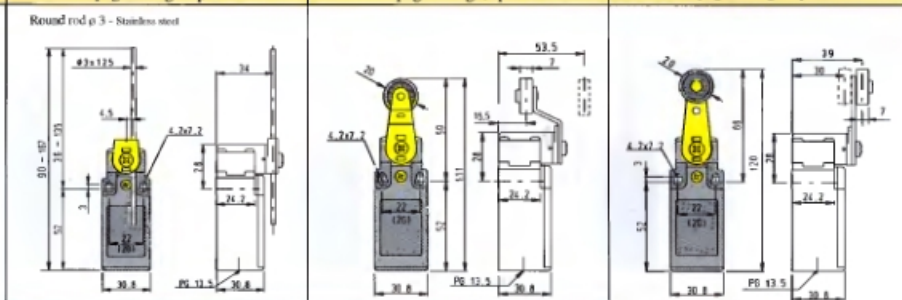

B5	Zb	snap action	FR 550 INO+INC	FR 551 ⊕ INO+INC	FR 552	⊕ INO+INC	
B6	Zb	slow action	FR 650 INO+INC	FR 651 ⊕ INO+INC	FR 652	⊕ INO+INC	
B7	Zb	slow action	FR 750 INO+INC Overlapped Contacts	FR 751 ⊕ INO+INC Overlapped Contacts	FR 752	⊕ INO+INC Overlapped Contacts	
B9	Y+Y	slow action	FR 950 2NC	FR 951 ⊕ 2NC	FR 952	⊕ 2NC	
B10	X+X	slow action	FR 1050 2NO	FR 1051 2NO	FR 1052	2NO	
B11	Y+Y	snap action	FR 1150 2NC	FR 1151 ⊕ 2NC	FR 1152	⊕ 2NC	
B14	Y+Y	slow action	FR 1450 2NC Shifted Contacts	FR 1451 ⊕ 2NC Shifted Contacts	FR 1452	⊕ 2NC Shifted Contacts	
B15	X+X	slow action	FR 1550 2NO Shifted Contacts	FR 1551 2NO Shifted Contacts	FR 1552	2NO Shifted Contacts	
B16	Y+Y	slow action	FR 1650 2NC Independent Contacts	FR 1651 ⊕ 2NC Independent Contacts	FR 1652	⊕ 2NC Independent Contacts	
B20	Y+Y+X	slow action	FR 2050 2NC+INO	FR 2051 ⊕ 2NC+INO	FR 2052	⊕ 2NC+INO	
B21	Y+Y+Y	slow action	FR 2150 3NC	FR 2151 ⊕ 3NC	FR 2152	⊕ 3NC	
B22	Y+X+X	slow action	FR 2250 INC+2NO	FR 2251 ⊕ INC+2NO	FR 2252	⊕ INC+2NO	
B2	Za+Za	snap action	FR 250 INO-INC+INO-INC	FR 251 INO-INC+INO-INC	FR 252	INO-INC+INO-INC	
Max. speed	1,5 m/s			page 49 - type 1		page 49 - type 1	
Min. force	9,8 Ncm			9,8 Ncm (25 Ncm)		9,8 Ncm (25 Ncm)	
Travel diagrams	page 48 - group 5			page 48 - group 5		page 48 - group 5	

Position switches without actuator

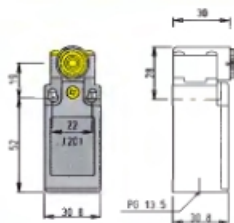

IMPORTANT:

For safety applications: combine only switches and levers showing near their references the symbol "⊕".
For some more information about applications for safety use see details on page 231.

B5	Zb	snap action	FR 538	⊕	INO+INC
B6	Zb	slow action	FR 638	⊖	INO+INC
B7	Zb	slow action	FR 738	⊖	INO+INC Overlapped Contacts
B9	Y+Y	slow action	FR 938	⊖	2NC
B10	X+X	slow action	FR 1038		2NO
B11	Y+Y	snap action	FR 1138	⊖	2NC
B14	Y+Y	slow action	FR 1438	⊖	2NC Shifted Contacts
B15	X+X	slow action	FR 1538		2NO Shifted Contacts
B16	Y+Y	slow action	FR 1638	⊖	2NC Independent Contacts
B20	Y+Y+X	slow action	FR 2038	⊖	2NC+INO
B21	Y+Y+Y	slow action	FR 2138	⊖	3NC
B22	Y+X+X	slow action	FR 2238	⊖	INC+2NO
B2	Za+Za	snap action	FR 238		INO-INC+INO-INC
Min. force			15 Ncm (15 Ncm)		
Travel diagrams			page 48 - group 5		

Loose actuators

IMPORTANT: These loose actuators can be used with series FR, FM, FX, FZ, FK only

VF LE30 ⊕ 10 pc	VF LE31 ⊕ 10 pc	VF LE33 10 pc	VF LE34 10 pc	VF LE50 10 pc	VF LE51 ⊕ 10 pc
VF LE52 ⊖ 10 pc	VF LE53 10 pc	VF LE54 ⊕ 10 pc	VF LE55 ⊕ 10 pc	VF LE56 ⊖ 10 pc	VF LE69 10 pc

The quantities given near the symbol indicate the number of pieces for pack. Only orders for multiple quantities of the packs are accepted.

* The VF LE55 lever suits for applications for safety uses only if adjusted on its max. length, as you can see in the figure on the right:

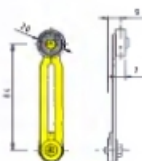

Position switches FM series



Technical data

Housing

Made of metal, coated with baked epoxy powder.
One conduit entry PG 13,5 or M20x1,5.

Protection degree: IP65

General data

Ambient temperature: from -25°C to +80°C
Max. operating frequency: 3600 operations/hour
Mechanical endurance: 20 millions of operations

Electrical data

Thermal current (Ith): 10A
Rated insulation voltage (Ui): 500 VAC 600 VDC
400 VAC per B20 - B21 - B22
Protection against short circuits: fuse 10A 500V type aM
Pollution degree: 3

Conforms to the standards:

IEC 947-5-1, IEC 337-1, EN 60947-5-1, CEI EN 60947-5-1, CEI 17-45, EN 50047, CEI 17-33, IEC 204-1, EN 60204-1, CEI 44-5, EN 1088, EN 292, IEC 529, EN 60529, CEI 70-1, NCF 63-140, VDE 0660-200, VDE 0113, CENELEC EN 50013.

Approval types:

IEC 947-5-1, UL 508, CSA C22-2 nr.14.

Utilization category

Alternate current: AC15 (50...60Hz)

Ue(V)	250	400	500
Ie(A)	6	3	1

Direct current: DC13

Ue(V)	24	125	250
Ie(A)	6	1.1	0.4

Markings and quality marks:

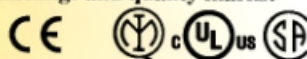

Approval type IMQ: EG609

Approval type UL: E131787

Approval type CSA: LR 93682-1

Complying with the requirements requested by:

Low Voltage Directive 73/23/EEC and subsequent modifications and completions, Machinery Directive 98/37/EEC, Electromagnetic Compatibility 89/336/EEC and subsequent modifications and completions.

Positive contact opening complying with the standards:

IEC 947-5-1, EN 60947-5-1, CEI EN 60947-5-1, VDE 0660-206.

Installation for safety applications :

Use only switches with the symbol "⊕" on their sides. Safety circuit must always be connected with the **NC contacts** (normally closed contacts: 11-12, 21-22 or 31-32) as stated in the **standard CEI EN 60947-5-1, encl. K, par. 2**. **The switch must be actuated with the minimum positive opening travel** shown in the travels diagrams on page 48. **The switch must be actuated with the minimum positive opening force**, shown in brackets, underneath each article, near the value of the min. force. For a correct installation of these articles see examples on page 231.

Data type approved by IMQ

- Rated insulation voltage (Ui) 500 VAC
400 VAC (for B20, B21, B22, B33, B34)
- Thermal current (Ith) 10A
- Protection against short circuits fuse 10A 500V type aM
- Protection degree of the housing IP65
- MV terminals (screw clamps)
- Pollution degree 3
- Utilization category AC15
- Operation voltage (Ue) 400 VAC (50 Hz)
- Operation current (Ie) 3A
- Forms of the contact element Za, Zb, Za+Za, Y+Y, X+X, Y+Y+X, Y+Y+Y, Y+X+X
- Positive opening of contacts on B5, B6, B7, B9, B11, B14, B16, B20, B21, B22, B33, B34
- Conforms to the standards: EN60947-1, EN 60947-1 A11, EN 60947-5-1 and fundamental requirements of the Low Voltage Directive 73/23 EEC and 93/68 EEC.

Please contact our technical service for the list of our type approved products

Data type approved by UL

- Utilization categories Q300 (69VA, 125-250 VDC)
A600 (720VA, 120-600 VAC)
- Data of the housing Type I, 4X
(indoor use only), 12, 13
- Conforms to the standard: UL 508

Please contact our technical service for the list of our type approved products

Data type approved by CSA

- Utilization categories Q300 (69VA, 125-250 VDC)
A600 (720VA, 120-600 VAC)
- Data of the housing Type I, 4X
(indoor use only), 12, 13
- Conforms to the standard: CSA C22-2 nr.14

Please contact our technical service for the list of our type approved products

FM series
metal housing

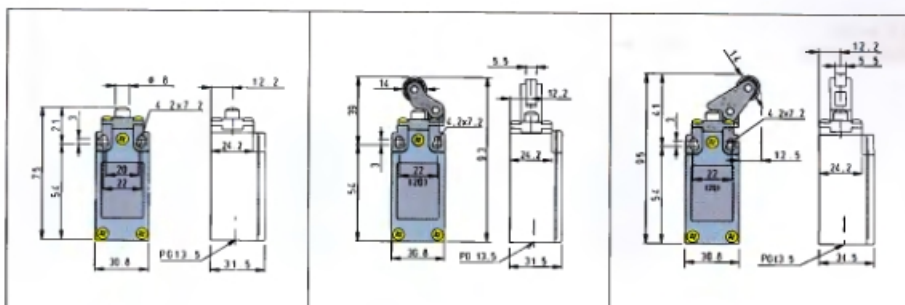

B5	Zb	snap action	FM 501	INO+INC	FM 502	INO+INC	FM 505	INO+INC
B6	Zb	slow action	FM 601	INO+INC	FM 602	INO+INC	FM 605	INO+INC
B7	Zb	slow action	FM 701	INO+INC Overlapped Contacts	FM 702	INO+INC Overlapped Contacts	FM 705	INO+INC Overlapped Contacts
B9	Y+Y	slow action	FM 901	2NC	FM 902	2NC	FM 905	2NC
B10	X+X	slow action	FM 1001	2NO	FM 1002	2NO	FM 1005	2NO
B11	Y+Y	snap action	FM 1101	2NC	FM 1102	2NC	FM 1105	2NC
B14	Y+Y	slow action	FM 1401	2NC Shifted Contacts	FM 1402	2NC Shifted Contacts	FM 1405	2NC Shifted Contacts
B15	X+X	slow action	FM 1501	2NO Shifted Contacts	FM 1502	2NO Shifted Contacts	FM 1505	2NO Shifted Contacts
B20	Y+Y+X	slow action	FM 2001	2NC+1NO	FM 2002	2NC+1NO	FM 2005	2NC+1NO
B21	Y+Y+Y	slow action	FM 2101	3NC	FM 2102	3NC	FM 2105	3NC
B22	Y+X+X	slow action	FM 2201	1NC+2NO	FM 2202	1NC+2NO	FM 2205	1NC+2NO
B2	Za+Za	snap action	FM 201	1NO-1NC+1NO-1NC	FM 202	1NO-1NC+1NO-1NC	FM 205	1NO-1NC+1NO-1NC
Max. speed			page 49 - type 4		page 49 - type 3		page 49 - type 3	
Min. force			8 N (20 N)		6 N (16 N)		6 N (18 N)	
Travel diagrams			page 48 - group 1		page 48 - group 2		page 48 - group 2	

FM series
metal housing

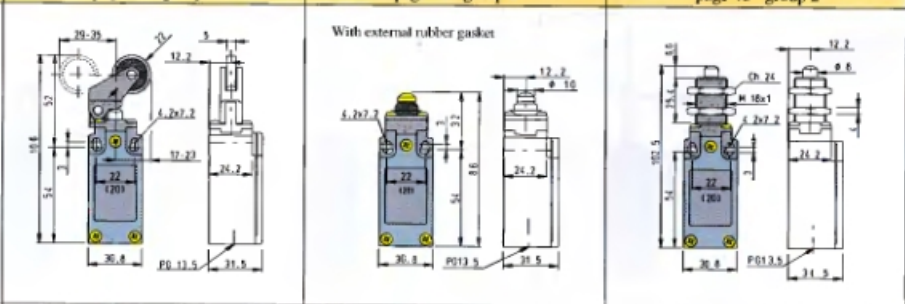

B5	Zb	snap action	FM 507	INO+INC	FM 508	INO+INC	FM 512	INO+INC
B6	Zb	slow action	FM 607	INO+INC	FM 608	INO+INC	FM 612	INO+INC
B7	Zb	slow action	FM 707	INO+INC Overlapped Contacts	FM 708	INO+INC Overlapped Contacts	FM 712	INO+INC Overlapped Contacts
B9	Y+Y	slow action	FM 907	2NC	FM 908	2NC	FM 912	2NC
B10	X+X	slow action	FM 1007	2NO	FM 1008	2NO	FM 1012	2NO
B11	Y+Y	snap action	FM 1107	2NC	FM 1108	2NC	FM 1112	2NC
B14	Y+Y	slow action	FM 1407	2NC Shifted Contacts	FM 1408	2NC Shifted Contacts	FM 1412	2NC Shifted Contacts
B15	X+X	slow action	FM 1507	2NO Shifted Contacts	FM 1508	2NO Shifted Contacts	FM 1512	2NO Shifted Contacts
B20	Y+Y+X	slow action	FM 2007	2NC+1NO	FM 2008	2NC+1NO	FM 2012	2NC+1NO
B21	Y+Y+Y	slow action	FM 2107	3NC	FM 2108	3NC	FM 2112	3NC
B22	Y+X+X	slow action	FM 2207	1NC+2NO	FM 2208	1NC+2NO	FM 2212	1NC+2NO
B2	Za+Za	snap action	FM 207	1NO-1NC+1NO-1NC	FM 208	1NO-1NC+1NO-1NC	FM 212	1NO-1NC+1NO-1NC
Max. speed			page 49 - type 3		page 49 - type 4		page 49 - type 4	
Min. force			4 N (14 N)		8 N (18 N)		8 N (20 N)	
Travel diagrams			page 48 - group 3		page 48 - group 1		page 48 - group 1	

Items with code on the green background are available in stock.

FM series
metal housing

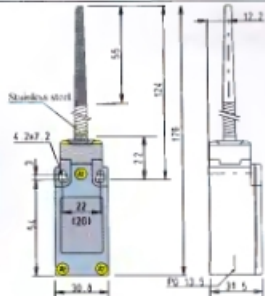
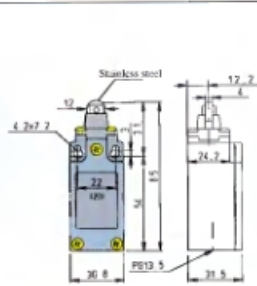
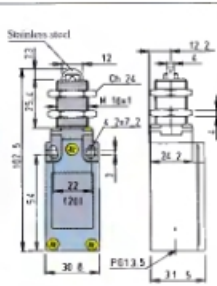

B5	Zb	snap action	FM 513	INO+INC	FM 515	INO+INC	FM 520	INO+INC
B6	Zb	slow action	FM 613	INO+INC	FM 615	INO+INC	/	/
B7	Zb	slow action	FM 713	INO+INC Overlapped Contacts	FM 715	INO+INC Overlapped Contacts	/	/
B9	Y+Y	slow action	FM 913	2NC	FM 915	2NC	/	/
B10	X+X	slow action	FM 1013	2NO	FM 1015	2NO	FM 1020	2NO
B11	Y+Y	snap action	FM 1113	2NC	FM 1115	2NC	/	/
B14	Y+Y	slow action	FM 1413	2NC Shifted Contacts	FM 1415	2NC Shifted Contacts	/	/
B15	X+X	slow action	FM 1513	2NO Shifted Contacts	FM 1515	2NO Shifted Contacts	/	/
B20	Y+Y+X	slow action	FM 2013	2NC+1NO	FM 2015	2NC+1NO	FM 2020	2NC+1NO
B21	Y+Y+Y	slow action	FM 2113	3NC	FM 2115	3NC	FM 2120	3NC
B22	Y+X+X	slow action	FM 2213	1NC+2NO	FM 2215	1NC+2NO	FM 2220	1NC+2NO
B2	Za+Za	snap action	FM 213	1NO-1NC+1NO-1NC	FM 215	1NO-1NC+1NO-1NC	FM 220	1NO-1NC+1NO-1NC
Max. speed	page 49 - type 4			page 49 - type 2			1 m/s	
Min. force	8 N (20 N)			8 N (18 N)			5,6 Ncm	
Travel diagrams	page 48 - group 1			page 48 - group 1			page 48 - group 4	

FM series
metal housing

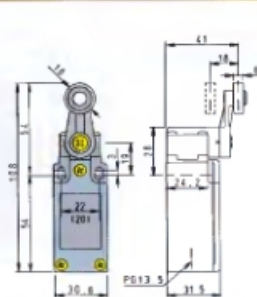
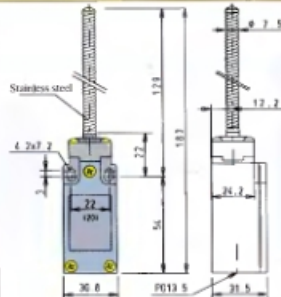
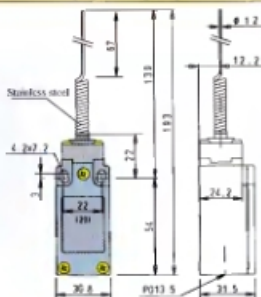

B5	Zb	snap action	FM 521	INO+INC	FM 525	INO+INC	FM 530	INO+INC
B6	Zb	slow action	/	/	/	/	FM 630	INO+INC
B7	Zb	slow action	/	/	/	/	FM 730	INO+INC Overlapped Contacts
B9	Y+Y	slow action	/	/	/	/	FM 930	2NC
B10	X+X	slow action	FM 1021	2NO	FM 1025	2NO	FM 1030	2NO
B11	Y+Y	snap action	/	/	/	/	FM 1130	2NC
B14	Y+Y	slow action	/	/	/	/	FM 1430	2NC Shifted Contacts
B15	X+X	slow action	/	/	/	/	FM 1530	2NO Shifted Contacts
B16	Y+Y	slow action	/	/	/	/	FM 1630	2NC Independent Contacts
B20	Y+Y+X	slow action	FM 2021	2NC+1NO	FM 2025	2NC+1NO	FM 2030	2NC+1NO
B21	Y+Y+Y	slow action	FM 2121	3NC	FM 2125	3NC	FM 2130	3NC
B22	Y+X+X	slow action	FM 2221	1NC+2NO	FM 2225	1NC+2NO	FM 2230	1NC+2NO
B2	Za+Za	snap action	FM 221	1NO-1NC+1NO-1NC	FM 225	1NO-1NC+1NO-1NC	FM 230	1NO-1NC+1NO-1NC
Max. speed	1 m/s			1 m/s			page 49 - type 1	
Min. force	3,9 Ncm			11,3 Ncm			9,8 Ncm (15 Ncm)	
Travel diagrams	page 48 - group 4			page 48 - group 4			page 48 - group 5	

FM series
metal housing

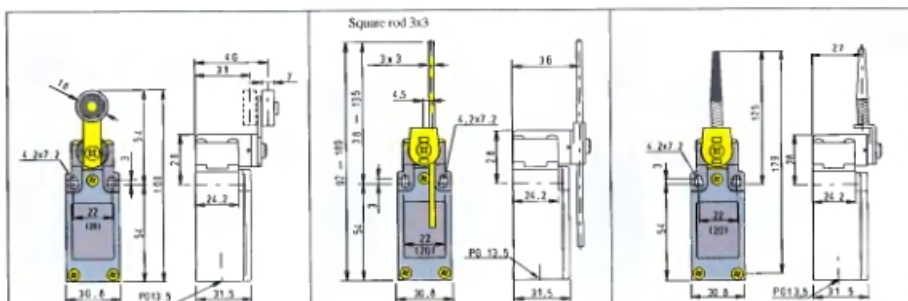

B5	Zb	snap action	FM 531	⊕	INO+INC	FM 533	INO+INC	FM 534	INO+INC
B6	Zb	slow action	FM 631	⊕	INO+INC	FM 633	INO+INC	FM 634	INO+INC
B7	Zb	slow action	FM 731	⊕	INO+INC Overlapped Contacts	FM 733	INO+INC Overlapped Contacts	FM 734	INO+INC Overlapped Contacts
B9	Y+Y	slow action	FM 931	⊕	2NC	FM 933	2NC	FM 934	2NC
B10	X+X	slow action	FM 1031	⊕	2NO	FM 1033	2NO	FM 1034	2NO
B11	Y+Y	snap action	FM 1131	⊕	2NC	FM 1133	2NC	FM 1134	2NC
B14	Y+Y	slow action	FM 1431	⊕	2NC Shifted Contacts	FM 1433	2NC Shifted Contacts	FM 1434	2NC Shifted Contacts
B15	X+X	slow action	FM 1531	⊕	2NO Shifted Contacts	FM 1533	2NO Shifted Contacts	FM 1534	2NO Shifted Contacts
B16	Y+Y	slow action	FM 1631	⊕	2NC Independent Contacts	FM 1633	2NC Independent Contacts	FM 1634	2NC Independent Contacts
B20	Y+Y+X	slow action	FM 2031	⊕	2NC+1NO	FM 2033	2NC+1NO	FM 2034	2NC+1NO
B21	Y+Y+Y	slow action	FM 2131	⊕	3NC	FM 2133	3NC	FM 2134	3NC
B22	Y+X+X	slow action	FM 2231	⊕	1NC+2NO	FM 2233	1NC+2NO	FM 2234	1NC+2NO
B2	Za+Za	snap action	FM 231	⊕	INO-INC+INO-INC	FM 233	INO-INC+INO-INC	FM 234	INO-INC+INO-INC
Max. speed	page 49 - type 1					1,5 m/s		1,5 m/s	
Min. force	9,8 Ncm (15 Ncm)					9,8 Ncm		9,8 Ncm	
Travel diagrams	page 48 - group 5					page 48 - group 5		page 48 - group 5	

FM series
metal housing

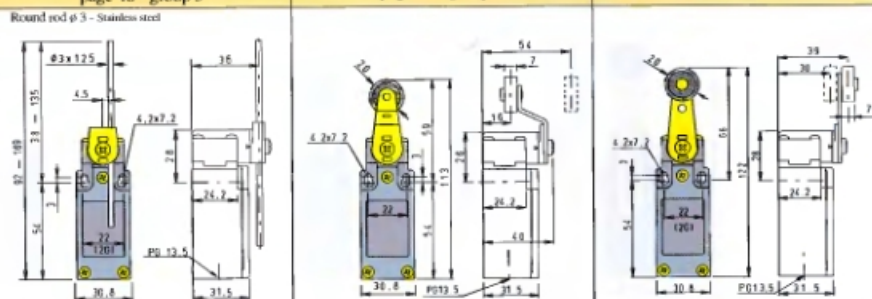

B5	Zb	snap action	FM 550	⊕	INO+INC	FM 551	⊕	INO+INC	FM 552	⊕	INO+INC
B6	Zb	slow action	FM 650	⊕	INO+INC	FM 651	⊕	INO+INC	FM 652	⊕	INO+INC
B7	Zb	slow action	FM 750	⊕	INO+INC Overlapped Contacts	FM 751	⊕	INO+INC Overlapped Contacts	FM 752	⊕	INO+INC Overlapped Contacts
B9	Y+Y	slow action	FM 950	⊕	2NC	FM 951	⊕	2NC	FM 952	⊕	2NC
B10	X+X	slow action	FM 1050	⊕	2NO	FM 1051	⊕	2NO	FM 1052	⊕	2NO
B11	Y+Y	snap action	FM 1150	⊕	2NC	FM 1151	⊕	2NC	FM 1152	⊕	2NC
B14	Y+Y	slow action	FM 1450	⊕	2NC Shifted Contacts	FM 1451	⊕	2NC Shifted Contacts	FM 1452	⊕	2NC Shifted Contacts
B15	X+X	slow action	FM 1550	⊕	2NO Shifted Contacts	FM 1551	⊕	2NO Shifted Contacts	FM 1552	⊕	2NO Shifted Contacts
B16	Y+Y	slow action	FM 1650	⊕	2NC Independent Contacts	FM 1651	⊕	2NC Independent Contacts	FM 1652	⊕	2NC Independent Contacts
B20	Y+Y+X	slow action	FM 2050	⊕	2NC+1NO	FM 2051	⊕	2NC+1NO	FM 2052	⊕	2NC+1NO
B21	Y+Y+Y	slow action	FM 2150	⊕	3NC	FM 2151	⊕	3NC	FM 2152	⊕	3NC
B22	Y+X+X	slow action	FM 2250	⊕	1NC+2NO	FM 2251	⊕	1NC+2NO	FM 2252	⊕	1NC+2NO
B2	Za+Za	snap action	FM 250	⊕	INO-INC+INO-INC	FM 251	⊕	INO-INC+INO-INC	FM 252	⊕	INO-INC+INO-INC
Max. speed	1,5 m/s					page 49 - type 1		page 49 - type 1			
Min. force	9,8 Ncm					9,8 Ncm (15 Ncm)		9,8 Ncm (15 Ncm)			
Travel diagrams	page 48 - group 5					page 48 - group 5		page 48 - group 5			

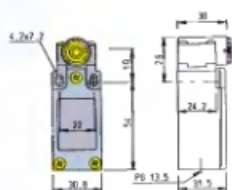

IMPORTANT:
For safety applications: combine only switches and levers showing near their references the symbol "⊕".
For more information about safety applications see details on page 231.

B5	Zb	snap action	FM 538	⊕	1NO+1NC
B6	Zb	slow action	FM 638	⊕	1NO+1NC
B7	Zb	slow action	FM 738	⊕	1NO+1NC Overlapped Contacts
B9	Y+Y	slow action	FM 938	⊕	2NC
B10	X+X	slow action	FM 1038		2NO
B11	Y+Y	snap action	FM 1138	⊕	2NC
B14	Y+Y	slow action	FM 1438	⊕	2NC Shifted Contacts
B15	X+X	slow action	FM 1538		2NO Shifted Contacts
B16	Y+Y	slow action	FM 1638	⊕	2NC Independent Contacts
B20	Y+Y+X	slow action	FM 2038	⊕	2NC+1NO
B21	Y+Y+Y	slow action	FM 2138	⊕	3NC
B22	Y+X+X	slow action	FM 2238	⊕	1NC+2NO
B2	Za+Za	snap action	FM 238		1NO-1NC+1NO-1NC
Min. force			15 Ncm (15 Ncm)		
Travel diagrams			page 48 - group 5		

Loose actuators

IMPORTANT: These loose actuators can be used with series FR, FM, FX, FZ, FK only

VF LE30 ⊕ 10 pc	VF LE31 ⊕ 10 pc	VF LE33 10 pc	VF LE34 10 pc	VF LE50 10 pc	VF LE51 ⊕ 10 pc
VF LE52 ⊕ 10 pc	VF LE53 ⊕ 10 pc	VF LE54 ⊕ 10 pc	VF LE55 ⊕ 10 pc	VF LE56 ⊕ 10 pc	VF LE69 10 pc

The quantities given near the symbol indicate the number of pieces for pack. Only orders for multiple quantities of the packs are accepted.

• The VF LE55 lever suits for applications for safety uses only if adjusted on its max. length, as you can see in the figure on the right:

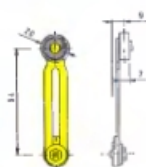

Microswitches M series



Technical data

Housing

Made of polymer glass-reinforced self-extinguishing and shock-resistant thermoplastic resin.

Protection degree: IP40 (with protection, article VF C02),
IP20 (with protection, article VF C01, VF C03)

General data

Ambient temperature: from -20°C to +85°C
Max. operating frequency: 3600 operations/hour
Mechanical endurance: from 10 to 20 millions of operations

Electrical data

Thermal current (Ith): 16A
Rated insulation voltage (Ui): 250 VAC 600 VDC
Protection from short circuits: fuse 16A 250V type gG
Pollution degree: 3
Dielectric strength: 2000 VAC/min between terminals and other metallic parts towards earth.

Conforms to the standards:

IEC 947-5-1, IEC 337-1, EN 60947-5-1, CEI EN 60947-5-1, CEI 17-45, CEI 23-11, IEC 529, EN 60529, CEI 70-1, CENELEC EN 50013

Approval types:

IEC 947-5-1

Complying with the requirements requested by:

Low voltage directive 73/23/EEC and subsequent modifications and completions, Machinery directive 98/37/EEC, Electromagnetic Compatibility 89/336/EEC and subsequent modifications and completions

Utilization categories

Alternate current: AC15 (50...60Hz)

Ue(V) 24 120 250

Ie(A) 7 6 5

Direct current: DC13

Ue(V) 24 125 250

Ie(A) 6 1.1 0.4

Markings and quality marks:

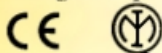

Approval type IMQ: EL285

Approvals IMQ

- Rated insulation voltage (Ui) 250 VAC
- Thermal current in pure air (Ith) 16A
- Protection against short circuits fuse 16A 250V type gG
- MV, MF, MS, MM terminals
- Pollution degree 3
- Utilization category AC15
- Operation voltage (Ue) 250 VAC (50 Hz)
- Operation current (Ie) 5A
- Forms of the contact element C

Compliance with the standards: EN60947-1, EN 60947 A11 and EN 60947-5-1 and fundamental requirements of the Directive Low Voltage 73/23 EEC and 93/68 EEC.

Please contact our technical service for the list of our type approved products

Wire diagram

with direct action

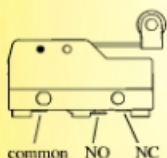

with inverted action



Kinds of terminals

MS solder terminals

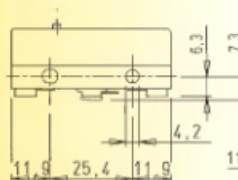

MV screw terminals

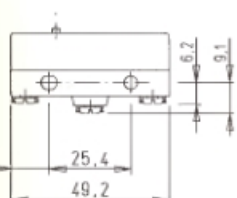
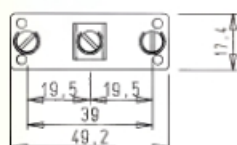

MF faston terminals

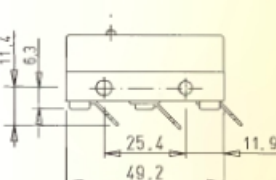
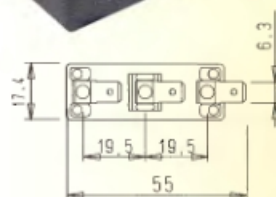

MM mantle terminals

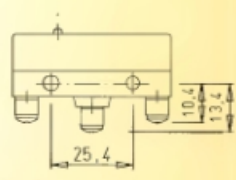
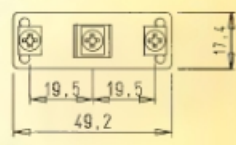

Fastening driving torques of the MS, MV and MM terminal screws : 0,8 ... 1,0 Nm

Protections (terminal covers)

Art. VF C01

100 pc. packs



Protection made of self-extinguishing shock-proof material for microswitches with terminals of the kind MS.

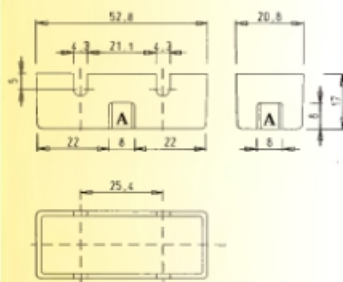

A DC breaking openings

Art. VF C02

100 pc. packs



Protection with cable gland PG 9, (multipolar cables ϕ min. 3mm, ϕ max. 6mm) made of shock-proof glass-reinforced material for terminals of the kinds MS, MV, MM.

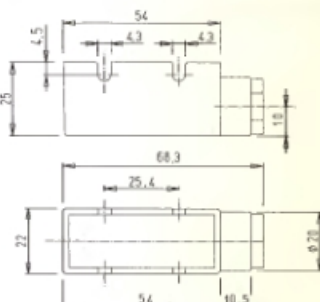

Art. VF C03

100 pc. packs



Protection with snap in assembly, made of self-extinguishing shock-proof material. For microswitches with terminals MS, MV, MM. It allows the installation of many switches side by side.

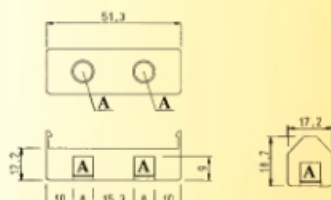

Quantities near the symbol  indicate the number of pieces in each pack. Only orders for multiple quantities of the packs are accepted.

Microswitches M series

Driving torques



Tighten the nut **1** M10 x 0,75 with a driving torques 2 ... 3 Nm.

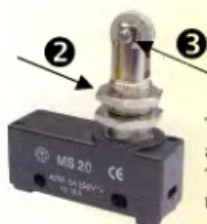

Tighten the nut **2** M12 x 1 with a driving torques 2 ... 3 Nm.
Tighten the nut **3** with a driving torques 0,3 ... 0,4 Nm.



Tighten the screws **4** M4 with a driving torques 1 ... 1,5 Nm.

How to order

MS 15

Type of terminals

MS	Solder terminals
MV	Screw terminals
MF	Faston terminals
MM	Mantle terminals

Actuators

01 . 49	with direct action
50 . 60	with reverse action

On request

- The plastic roller $\varnothing 9,5 \times 4$ can be furnished in metal.
- MF terminals with faston oriented to the opposite side.
- The plastic roller $\varnothing 9,5 \times 4$ can be furnished in wide version $\varnothing 9,5 \times 7,8$ in the articles with actuator ...40, ...42, ...53, ...54, ...55.
- Special versions on request.

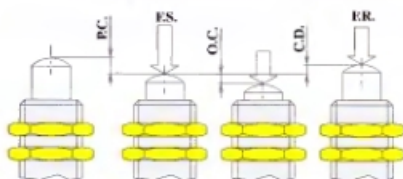
Legend forces and travels
F.S. = Operating force

F.R. = Releasing force







P.C. = Pretravel

O.C. = Over-travel

C.D. = Differential travel

MICROSWITCHES WITH DIRECT ACTION

DIMENSIONS	ARTICLE	FORCES AND TRAVELS
	with pin	10 pc. packs
	MS 01	F.S. = 350 gr. max.
	MV 01	F.R. = 200 gr. min.
	MF 01	P.C. = 0,5 mm max.
	MM 01	O.C. = 0,2 mm min. C.D. = 0,05 mm max.
	with pin	10 pc. packs
	MS 02	F.S. = 350 gr. max.
	MV 02	F.R. = 200 gr. min.
	MF 02	P.C. = 0,5 mm max.
	MM 02	O.C. = 0,2 mm min. C.D. = 0,05 mm max.
	with small push button	10 pc. packs
	MS 03	F.S. = 350 gr. max.
	MV 03	F.R. = 200 gr. min.
	MF 03	P.C. = 0,5 mm max.
	MM 03	O.C. = 1,5 mm min. C.D. = 0,05 mm max.
	with small push button	10 pc. packs
	MS 04	F.S. = 350 gr. max.
	MV 04	F.R. = 200 gr. min.
	MF 04	P.C. = 0,5 mm max.
	MM 04	O.C. = 1,5 mm min. C.D. = 0,05 mm max.
	with low push button	10 pc. packs
	MS 05	F.S. = 350 gr. max.
	MV 05	F.R. = 200 gr. min.
	MF 05	P.C. = 0,5 mm max.
	MM 05	O.C. = 1,5 mm min. C.D. = 0,05 mm max.
	with push button	10 pc. packs
	MS 06	F.S. = 350 gr. max.
	MV 06	F.R. = 200 gr. min.
	MF 06	P.C. = 0,5 mm max.
	MM 06	O.C. = 2 mm min. C.D. = 0,05 mm max.

DIMENSIONS	ARTICLE	FORCES AND TRAVELS
	with high push button  10 pc. packs MS 08 MV 08 MF 08 MM 08	F.S. = 350 gr. max. F.R. = 200 gr. min. P.C. = 0,5 mm max. O.C. = 5,5 mm min. C.D. = 0,05 mm max.
	with push button  10 pc. packs MS 09 MV 09 MF 09 MM 09	F.S. = 350 gr. max. F.R. = 200 gr. min. P.C. = 0,5 mm max. O.C. = 5,5 mm min. C.D. = 0,05 mm max.
	with push button  10 pc. packs MS 10 MV 10 MF 10 MM 10	F.S. = 350 gr. max. F.R. = 200 gr. min. P.C. = 0,5 mm max. O.C. = 5,5 mm min. C.D. = 0,05 mm max.
	with protected push button  10 pc. packs MS 12 MV 12 MF 12 MM 12	F.S. = 550 gr. max. F.R. = 400 gr. min. P.C. = 1 mm max. O.C. = 5 mm min. C.D. = 0,05 mm max.
	with protected push button  10 pc. packs MS 13 MV 13 MF 13 MM 13	F.S. = 800 gr. max. F.R. = 650 gr. min. P.C. = 1 mm max. O.C. = 5 mm min. C.D. = 0,05 mm max.
	push button with roller  10 pc. packs MS 15 MV 15 MF 15 MM 15	F.S. = 350 gr. max. F.R. = 200 gr. min. P.C. = 0,5 mm max. O.C. = 5,5 mm min. C.D. = 0,05 mm max.
	push button with transverse roller  10 pc. packs MS 17 MV 17 MF 17 MM 17	F.S. = 350 gr. max. F.R. = 200 gr. min. P.C. = 0,5 mm max. O.C. = 5,5 mm min. C.D. = 0,05 mm max.

DIMENSIONS	ARTICLE	FORCES AND TRAVELS
	push button with orientable roller 10 pc. packs MS 20 MV 20 MF 20 MM 20	F.S. = 350 gr. max. F.R. = 200 gr. min. P.C. = 0,5 mm max. O.C. = 5,5 mm min. C.D. = 0,05 mm max.
	with lever 10 pc. packs MS 30 MV 30 MF 30 MM 30	F.S. = 50 gr. max. F.R. = 30 gr. min. P.C. = 10 mm max. O.C. = 6 mm min. C.D. = 1,5 mm max.
	with lever 10 pc. packs MS 32 MV 32 MF 32 MM 32	F.S. = 60 gr. max. F.R. = 40 gr. min. P.C. = 8 mm max. O.C. = 5 mm min. C.D. = 1 mm max.
	with lengthened lever 10 pc. packs MS 35 MV 35 MF 35 MM 35	F.S. = 32 gr. max. F.R. = 26 gr. min. P.C. = 20 mm max. O.C. = 15 mm min. C.D. = 4 mm max.
	with wire lever 10 pc. packs MS 37 MV 37 MF 37 MM 37	F.S. = 10 gr. max. F.R. = 5 gr. min. P.C. = 20 mm max. O.C. = 10 mm min. C.D. = 4 mm max.
	with roller lever 10 pc. packs MS 40 MV 40 MF 40 MM 40	F.S. = 60 gr. max. F.R. = 40 gr. min. P.C. = 8 mm max. O.C. = 5 mm min. C.D. = 1 mm max.
	with roller lever 10 pc. packs MS 42 MV 42 MF 42 MM 42	F.S. = 80 gr. max. F.R. = 50 gr. min. P.C. = 6 mm max. O.C. = 3 mm min. C.D. = 0,8 mm max.

DIMENSIONS	ARTICLE	FORCES AND TRAVELS
	with roller lever MS 45 MV 45 MF 45 MM 45	10 pc. packs F.S. = 110 gr. max. F.R. = 70 gr. min. P.C. = 3,5 mm max. O.C. = 2,5 mm min. C.D. = 0,6 mm max.
	with one-way roller lever MS 47 MV 47 MF 47 MM 47	10 pc. packs F.S. = 110 gr. max. F.R. = 70 gr. min. P.C. = 3,5 mm max. O.C. = 2,5 mm min. C.D. = 0,6 mm max.
	with red button MS 49 MV 49 MF 49 MM 49	10 pc. packs Hand operation
MICROSWITCHES WITH INVERTED ACTION		
	with lever MS 50 MV 50 MF 50 MM 50	10 pc. packs F.S. = 80 gr. max. F.R. = 60 gr. min. P.C. = 4 mm max. O.C. = 6 mm min. C.D. = 0,6 mm max.
	with lever MS 52 MV 52 MF 52 MM 52	10 pc. packs F.S. = 70 gr. max. F.R. = 50 gr. min. P.C. = 5 mm max. O.C. = 8 mm min. C.D. = 0,6 mm max.
	with roller lever MS 53 MV 53 MF 53 MM 53	10 pc. packs F.S. = 80 gr. max. F.R. = 60 gr. min. P.C. = 4 mm max. O.C. = 8 mm min. C.D. = 0,6 mm max.
	with roller lever MS 54 MV 54 MF 54 MM 54	10 pc. packs F.S. = 100 gr. max. F.R. = 60 gr. min. P.C. = 4 mm max. O.C. = 6 mm min. C.D. = 0,6 mm max.

DIMENSIONS	ARTICLE	FORCES AND TRAVELS
	with roller lever MS 55 MV 55 MF 55 MM 55	10 pc. packs F.S. = 120 gr. max. F.R. = 70 gr. min. P.C. = 3 mm max. O.C. = 5 mm min. C.D. = 0,5 mm max.
	with one-way roller lever MS 57 MV 57 MF 57 MM 57	10 pc. packs F.S. = 140 gr. max. F.R. = 80 gr. min. P.C. = 2 mm max. O.C. = 2,5 mm min. C.D. = 0,3 mm max.
	with roller lever MS 58 MV 58 MF 58 MM 58	10 pc. packs F.S. = 140 gr. max. F.R. = 80 gr. min. P.C. = 2 mm max. O.C. = 2,5 mm min. C.D. = 0,3 mm max.
	with roller lever MS 59 MV 59 MF 59 MM 59	10 pc. packs F.S. = 240 gr. max. F.R. = 150 gr. min. P.C. = 1,5 mm max. O.C. = 3 mm min. C.D. = 0,2 mm max.
	lever with adjustable screw MS 60 MV 60 MF 60 MM 60	10 pc. packs F.S. = 120 gr. max. F.R. = 70 gr. min. P.C. = 21 ÷ 43 mm O.C. = 5 mm min. C.D. = 0,5 mm max.

Heavy duty key safety switches



Technical data

Housing

FP series made of polymer glass-reinforced, self-extinguishing, shock proof thermoplastic resin with double insulation. □
FD, FL and FC series made of metal, coated with baked epoxy powder.
FD and FP series one conduit entry PG 13,5 or M20x1,5.
FL series three conduit entries PG 13,5 or M20x1,5.
FC series one conduit entry PG 11 or M16x1,5.

Protection degree: IP66 (electrical contacts)

General data

Ambient temperature: from -25°C to +80°C
Max operating frequency: 3600 operating cycles/hour
Mechanical endurance: 1 million of operations
Max. actuating speed: 0,5 m/s
Min. actuating speed: 1 mm/s

Electrical data

Thermal current (I_{th}): 10A
Rated insulation voltage (U_i): 500 VAC 600 VAC
400 VAC for B20-B21-B22-B33-B34
Protection against short circuits: fuse 10A 500V type aM
Pollution degree: 3

Conforms to the standards:

IEC 947-5-1, IEC 337-1, EN 60947-5-1, CEI EN 60947-5-1, CEI 17-45, IEC 204-1, EN 60204-1, CEI 44-5, EN 1088, EN 292, IEC 529, EN 60529, CEI 70-1, NCF 63-140, VDE 0660-200, VDE 0113, CENELEC EN 50013.

Approval types:

IEC 947-5-1, UL 508.

Complying with the requirements requested by:

Low Voltage Directive 73/23/EEC and subsequent modifications and completions, Machinery Directive 98/37/EEC, Electromagnetic Compatibility 89/336/EEC and subsequent modifications and completions.

Positive contact opening complying with the standards:

IEC 947-5-1, EN 60947-5-1, CEI EN 60947-5-1, VDE 0660-206.

Utilization categories

Alternate current: AC15 (50...60Hz)

U _e (V)	250	400	500
--------------------	-----	-----	-----

I _e (A)	6	3	1
--------------------	---	---	---

Direct current: DC13

U _e (V)	24	125	250
--------------------	----	-----	-----

I _e (A)	6	1.1	0.4
--------------------	---	-----	-----

Markings and quality marks:

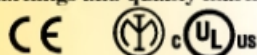

Approval type IMQ: EG605 (FD series)
EG606 (FP series)
EG607 (FL series)
EG608 (FC series)

Approval type UL: E131787

Installation for safety applications :

The switch must be actuated with the minimum positive opening travel shown in the travels diagrams with the symbol ☺. **The switch must be actuated with the minimum positive opening force**, shown in brackets, underneath each article, near the value of the min. force.

Data type approved by IMQ

- Rated insulation voltage (U_i) 500 VAC
400 VAC (for B20, B21, B22, B33, B34)
- Thermal current (I_{th}) 10A
- Protection against short circuits fuse 10A 500V type aM
- Protection degree of the housing IP66
- MV terminals (screw clamps)
- Pollution degree 3
- Utilization category AC15
- Operation voltage (U_e) 400 VAC (50 Hz)
- Operation current (I_e) 3A
- Forms of the contact element Zb, Y+Y, Y+Y+X, Y+Y+Y, Y+X+X
- Positive opening of contacts on B6, B7, B9, B20, B21, B22, B33, B34
- Conforms to the standards: EN60947-1, EN 60947-1 A11, EN 60947-5-1 and fundamental requirements of the Low Voltage Directive 73/23 EEC and 93/68 EEC.

Please contact our technical service for the list of our type approved products

Data type approved by UL

- Utilization categories Q300 (69VA, 125-250 VDC)
A600 (720VA, 120-600 VAC)
- Data of the housing Type 1, 4X
(indoor use only), 12, 13
- Conforms to the standard: UL 508

Please contact our technical service for the list of our type approved products

Description

These safety switches are ideal for the control of gates, sliding doors and other guards protecting dangerous parts of machines. The actuating key made of stainless steel is fastened to the moving part of the guard, so that it is removed from the switch on opening of the guard. The switch mechanism guarantees that removing the key forces the positive opening of the electrical contacts. Easy to install, these switches can be applied to every kind of protection (with hinge, sliding and removable ones). Besides, the possibility to actuate the switch only with that particular key guarantees that the machine can be restarted only when the guard has been closed. Made of rugged materials and with oversized thickness, these switches are designed for the use on heavy guards under critical environments conditions.

Dimensional drawing

IMPORTANT:

The NC contact is closed when actuating key is inserted.

	Polymer housing Unit without actuating key	Metal housing Unit without actuating key	Metal housing Unit without actuating key
B6 Zb slow action	FP 693 INO+INC 	FD 693 INO+INC 	FL 693 INO+INC
B7 Zb slow action	FP 793 INO+INC 	FD 793 INO+INC 	FL 793 INO+INC
B9 Y+Y slow action	FP 993 2NC 	FD 993 2NC 	FL 993 2NC
B20 Y+X slow action	FP 2093 2NC+INO 	FD 2093 2NC+INO 	FL 2093 2NC+INO
B21 Y+Y slow action	FP 2193 3NC 	FD 2193 3NC 	FL 2193 3NC
B22 Y+X slow action	FP 2293 INC+2NO 	FD 2293 INC+2NO 	FL 2293 INC+2NO
B33 Zb slow action	FP 3393 INO+INC 	FD 3393 INO+INC 	FL 3393 INO+INC
B34 Y+Y slow action	FP 3493 2NC 	FD 3493 2NC 	FL 3493 2NC
Min. force	10 N (18 N)	10 N (18 N)	10 N (18 N)

How to read diagrams (All measures in the diagrams are in mm).

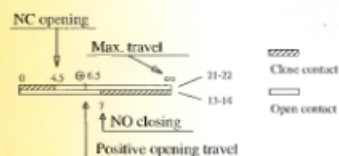

Heavy duty key safety switches

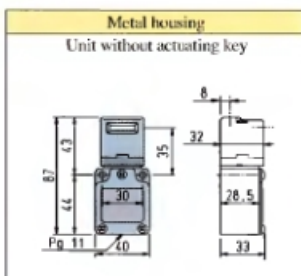

How to read diagrams

(All measures in the diagrams are in mm.)

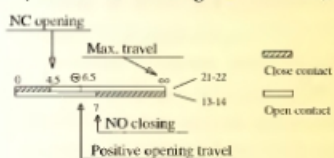







B33 Zb slow action		FC 3393 1NO+1NC
B34 Y+Y slow action		FC 3493 2NC
Min. force		10 N (18 N)

Actuating keys

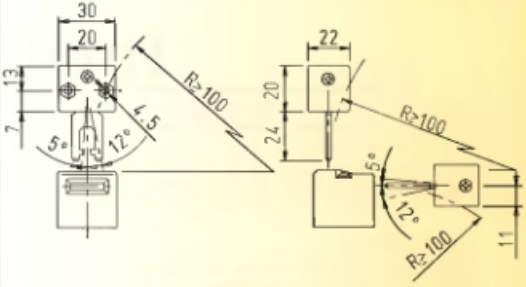
Caution! These keys must be used only with products having code beginning with "FD", "FP", "FL", "FC" or "FS" (i.e. FD 693)

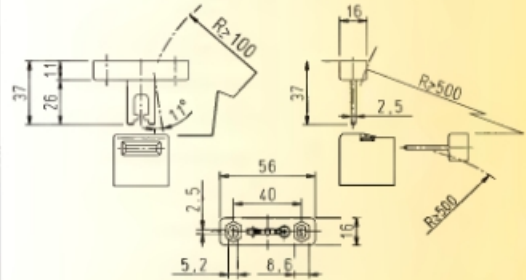
Actuating keys	Description	Outline dimensions and bending radiuses
Art. VF KEYF 10 pc. packs 	Straight key	
Art. VF KEYF1 10 pc. packs 	Right-angled key	
Art. VF KEYF2 10 pc. packs 	The key can flex in four directions for applications where the door alignment is not precise.	

Actuating keys	Description	Outline dimensions and bending radiuses
<p>Art. VF KEYF3</p> <p>10 pc. packs </p> 	<p>The key can flex in two directions for doors of reduced dimension.</p>	
<p>Art. VF KEYF7</p> <p>10 pc. packs </p> 	<p>The key can flex in one direction for doors of reduced dimension.</p>	

Items with code on **green** background are available in stock. The quantities near the symbol  indicate the number of pieces in each pack. Only orders for quantities multiple of the packs are accepted.

For other accessories : **lamps, cable glands, thread adapters and connectors**, see the section with the general characteristics of the heavy series on page 14.

Installation examples

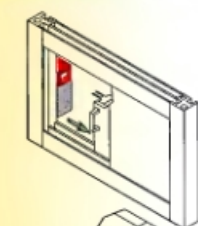

1) Sliding guards

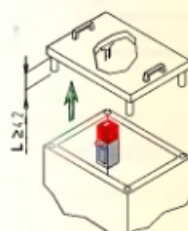

2) Scuttle guards

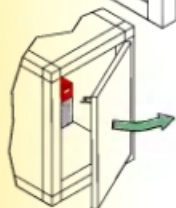

3) Hinge guards

4) Removable guards

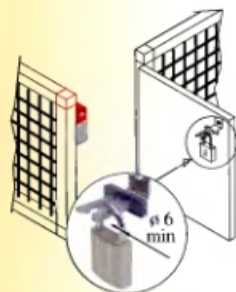
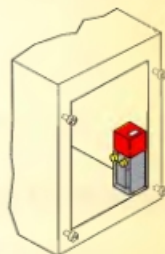
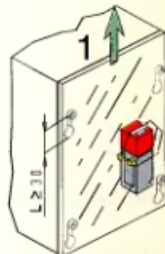

5) Installation on fences

In some cases the switch may be protecting a gate which allows access to an area large enough for a person to enter. In such cases it is vital that the gate be prevented from accidentally closing while someone is in the hazardous area. The keys are designed to accept a padlock with a 6 mm minimum lock bar diameter.

Heavy duty key safety switches

How to order

Housing		FD 693-FM2		Threaded coupling	
FD	metal housing, one conduit entry				coupling PG 13,5
FL	metal housing, three conduit entries			M2	coupling M20x1,5
FP	polymer housing, one conduit entry				
Contact block		Actuating keys			
B6	1NO+1NC, slow action				without actuating key
B7	1NO+1NC, slow action (overlapped contact)	F			with straight key
B9	2NC, slow action	F1			with right-angled key
B20	2NC+1NO, slow action	F2			with jointed key
B21	3NC, slow action	F3			with adjustable jointed key
B22	1NC+2NO, slow action	F7			with adjustable jointed key
B33	1NO+1NC, slow action				
B34	2NC, slow action				

Housing		FC 3393-FM1		Threaded coupling	
FC	metal housing, one conduit entry				coupling PG 11
				M1	coupling M16x1,5
Contact block		Actuating key			
B33	1NO+1NC, slow action				without actuating key
B34	2NC, slow action	F			with straight key
		F1			with right-angled key
		F2			with jointed key
		F3			with adjustable jointed key
		F7			with adjustable jointed key

Maximum cross section of the conductors (flexible lead wire) in the contact blocks

Contact blocks B20, B21, B22, B33, B34	Contact blocks B6, B7, B9
2 x 1,5 mm ² (2 x AWG 16)	2 x 2,5 mm ² (2 x AWG 14)

Assembling instructions



To rotate the head, unscrew the two screws as shown above.



The head can be rotated on the four sides of the switch

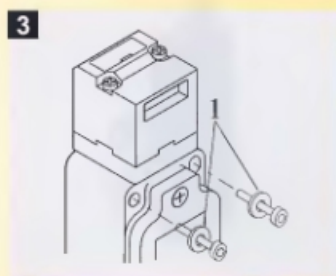

Fix the switch by interposing a washer (1) under the heads of the fastening screws (only series FP).

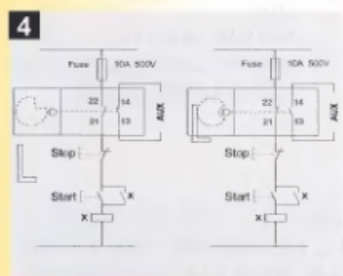

The safety circuit must be connected to the NC contacts (11-12, 21-22, 31-32) with inserted key. The auxiliary contacts (13-14, 23-24, 33-34) are for signalling purposes.



Fasten the key to the door of the machine with rivets or one way screws (2).

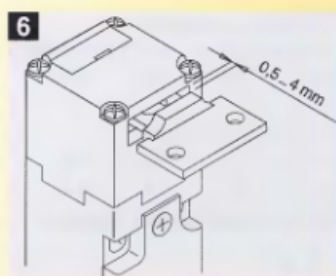

With closed door, check that the key is in the adjustment zone (0.5...4 mm).

Attention!

Check the correct operation of the switch, before you start the machine and then, from time to time. The machine should immediately stop every time the guard is opened.

Instructions

A) Do not use in the following environments: where dust and dirt may penetrate in any way into the head and deposit there, in particular where metal dust, concrete or chemicals are spread.

Do not use under conditions where explosive or inflammable gas is present.

B) Mechanical stop: do not use the switch as a mechanical stop. The actuating key should not knock straight against the head of the switch (see figure on the side).

C) Care during the installation and after: Always insert the plug in the slot not used for protection against dust.

D) Care in the use of the actuating keys:

- Attach the keys with rivets or one way screws.

- Take care to use only the actuating key furnished with the switch or to use one of the following loose keys: VF KEYF, VF KEYF1, VF KEYF2, VF KEYF3, VF KEYF7.

If you use any other key, the safety of the system is not guaranteed.

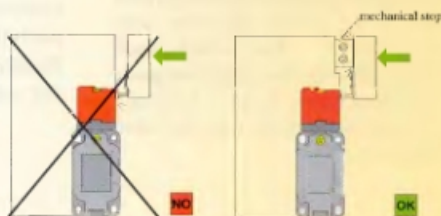

On request

- Versions with M12 connector, made of plastic or metal, already wired.
- Special versions for -40°C use.
- Special versions with head oriented towards left, right, the rear.
- Custom-made special versions.

Rope safety switches **without reset** for simple stop



Utilization categories

Alternate current: AC15 (50...60Hz)

Ue(V)	250	400	500
-------	-----	-----	-----

Ie(A)	6	3	1
-------	---	---	---

Direct current: DC13

Ue(V)	24	125	250
-------	----	-----	-----

Ie(A)	6	1.1	0.4
-------	---	-----	-----

Markings and quality marks:

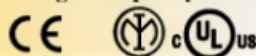

Approval type IMQ: EG605 (FD series)

EG606 (FP series)

EG607 (FL series)

Approval type UL: E131787

Installation for safety applications :

The switch must be actuated with the minimum positive opening travel shown in the Travel diagrams with the symbol \ominus . The switch must be actuated with the minimum positive opening force, shown in brackets, underneath each article, near the value of the min. force.

Data type approved by IMQ

- Rated insulation voltage (Ui) 500 VAC
400 VAC (for B20, B21, B22, B33, B34)
- Thermal current (Ith) 10A
- Protection against short circuits fuse 10A 500V type aM
- Protection degree of the housing IP66
- MV terminals (screw clamps)
- Pollution degree 3
- Utilization category AC15
- Operation voltage (Ue) 400 VAC (50 Hz)
- Operation current (Ie) 3A
- Forms of the contact element Zb, Y+Y, Y+Y+X, Y+Y+Y, Y+X+X
- Positive opening of contacts on B6, B8, B9, B20, B21, B22, B33, B34
- Conforms to the standards: EN60947-1, EN 60947-1 A11, EN 60947-5-1 and fundamental requirements of the Low Voltage Directive 73/23 EEC and 93/68 EEC.

Please contact our technical service for the list of our type approved products

Technical data

Housing

FP made of polymer glass-reinforced, self-extinguishing, shock proof thermoplastic resin and with double insulation. \square

FD, FL and FC series made of metal, coated with baked epoxy powder.

FD and FP series one conduit entry PG 13,5 or M20x1,5.

FL series three conduit entries PG 13,5 or M20x1,5.

FC series one conduit entry PG 11 or M16x1,5.

Protection degree: IP66

General data

Ambient temperature: from -25°C to +80°C

Max operating frequency: 2 operating cycles/12s

Mechanical endurance: 1 million of operations

Max. actuating speed: 0,5 m/s

Min. actuating speed: 1 mm/s

Electrical data

Thermal current (Ith): 10A

Rated insulation voltage (Ui): 500 VAC 600 VDC

400 VAC for B20-B21-B22-B33-B34

Protection against short circuits: fuse 10A 500V type aM

Pollution degree: 3

Conforms to the standards:

IEC 947-5-1, EN 60947-5-1, CEI EN 60947-5-1, CEI 17-45, EN 1088, EN 292, NCF 63-140, VDE 0660-200, VDE 0113, CENELEC EN 50013.

Approval types:

IEC 947-5-1, UL 508.

Complying with the requirements requested by:

Low Voltage Directive 73/23/EEC and subsequent modifications and completions, Machinery Directive 98/37/EEC, Electromagnetic Compatibility 89/336/EEC and subsequent modifications and completions.

Positive contact opening complying with the standards:

IEC 947-5-1, EN 60947-5-1, CEI EN 60947-5-1, VDE 0660-206.

Data type approved by UL

- Utilization categories Q300 (69VA, 125-250 VDC)
A600 (720VA, 120-600 VAC)
- Data of the housing Type 1, 4X
(indoor use only), 12, 13
- Conforms to the standard: UL 508

Please contact our technical service for the list of our type approved products

Description

These rope operated safety switches are installed on machines or conveyor belts, activating the emergency stop of the machine from every place and by every intervention by hand on the rope.

Provided with a **self-control function**, they check constantly their correct working operation, signalling with the opening of the contacts an eventual loosening or break-out of the rope.

Travel diagrams (All measures in the diagrams are in mm).

Contact blocks	Heads groups	Group 1	Group 2	Group 3
B6 1NO+1NC	$\begin{matrix} 13 & 21 \\ \swarrow & \searrow \\ 7 & 7 \\ \downarrow & \downarrow \\ 14 & 22 \end{matrix}$			
B8 1NC	$\begin{matrix} 11 & 21 \\ \swarrow & \searrow \\ 7 & 7 \\ \downarrow & \downarrow \\ 12 & 22 \end{matrix}$			
B9 2NC	$\begin{matrix} 11 & 21 \\ \swarrow & \searrow \\ 7 & 7 \\ \downarrow & \downarrow \\ 12 & 22 \end{matrix}$			
B20 2NC+1NO	$\begin{matrix} 11 & 23 & 33 \\ \swarrow & \searrow & \swarrow \\ 7 & 7 & 7 \\ \downarrow & \downarrow & \downarrow \\ 12 & 22 & 34 \end{matrix}$			
B21 3NC	$\begin{matrix} 11 & 21 & 31 \\ \swarrow & \searrow & \swarrow \\ 7 & 7 & 7 \\ \downarrow & \downarrow & \downarrow \\ 12 & 22 & 32 \end{matrix}$			
B22 1NC+2NO	$\begin{matrix} 11 & 23 & 33 \\ \swarrow & \searrow & \swarrow \\ 7 & 7 & 7 \\ \downarrow & \downarrow & \downarrow \\ 12 & 24 & 34 \end{matrix}$			
B33 1NC+1NO	$\begin{matrix} 13 & 21 \\ \swarrow & \searrow \\ 7 & 7 \\ \downarrow & \downarrow \\ 14 & 22 \end{matrix}$			
B34 2NC	$\begin{matrix} 11 & 21 \\ \swarrow & \searrow \\ 7 & 7 \\ \downarrow & \downarrow \\ 12 & 22 \end{matrix}$			

How to read diagrams

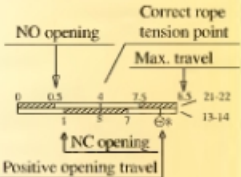

Closed contact
 Open contact

FD series metal housing

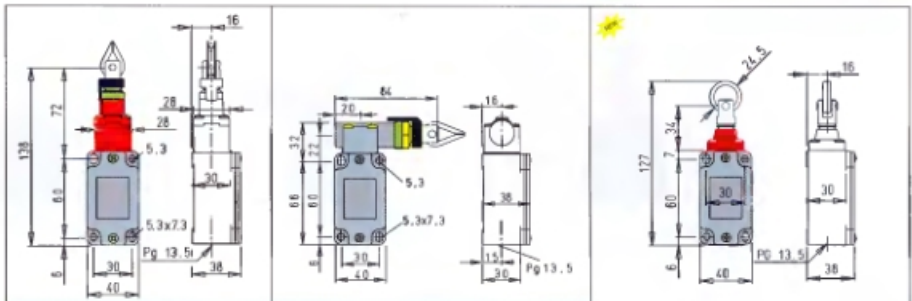

B6	Zb	slow action	FD 679 ⊕ 1NO+1NC	FD 680 ⊕ 1NO+1NC	/
B8	Y	slow action	/	/	FD 874 ⊕ 1NC
B9	Y+Y	slow action	FD 979 ⊕ 2NC	FD 980 ⊕ 2NC	/
B20	Y+Y+X	slow action	FD 2079 ⊕ 2NC+1NO	FD 2080 ⊕ 2NC+1NO	/
B21	Y+Y+Y	slow action	FD 2179 ⊕ 3NC	FD 2180 ⊕ 3NC	/
B22	Y+X+X	slow action	FD 2279 ⊕ 1NC+2NO	FD 2280 ⊕ 1NC+2NO	/
B33	Zb	slow action	FD 3379 ⊕ 1NO+1NC	FD 3380 ⊕ 1NO+1NC	/
B34	Y+Y	slow action	FD 3479 ⊕ 2NC	FD 3480 ⊕ 2NC	/
Min. force			Initial 63 N ... final 83 N (90 N)	Initial 147 N ... final 235 N (250 N)	Initial 63 N ... final 83 N (90 N)
Travel diagrams			page 190 - group 1	page 190 - group 2	page 190 - group 3

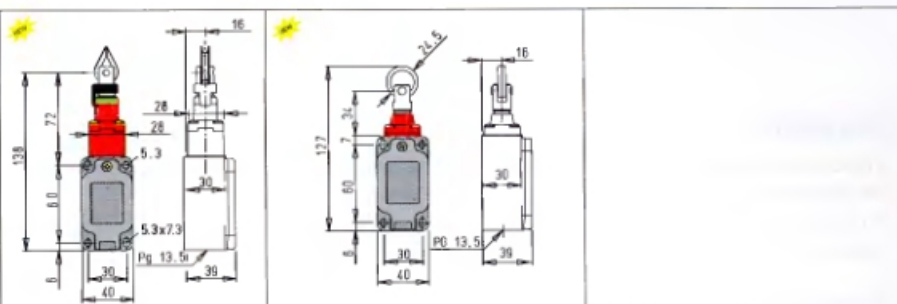

B6	Zb	slow action	FP 679	⊕ INO+INC	/	
B8	Y	slow action	/		FP 874	⊕ INC
B9	Y+Y	slow action	FP 979	⊕ 2NC	/	
B20	Y+Y+X	slow action	FP 2079	⊕ 2NC+INO	/	
B21	Y+Y+Y	slow action	FP 2179	⊕ 3NC	/	
B22	Y+X+X	slow action	FP 2279	⊕ INC+2NO	/	
B33	Zb	slow action	FP 3379	⊕ INO+INC	/	
B34	Y+Y	slow action	FP 3479	⊕ 2NC	/	
Min. force			Initial 63 N ... final 83 N (90 N)		Initial 63 N ... final 83 N (90 N)	
Travel diagrams			page 190 - group 1		page 190 - group 3	

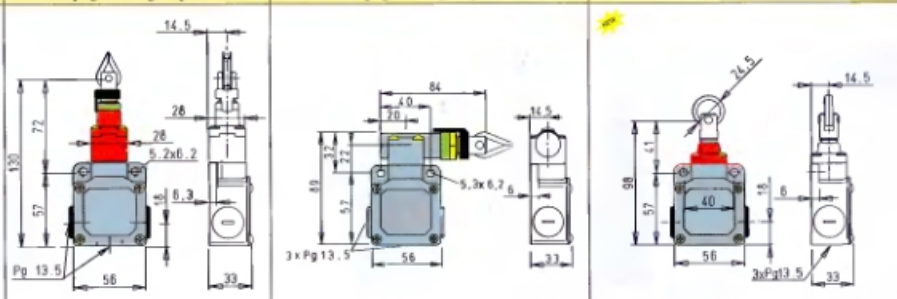

B6	Zb	slow action	FL 679	⊕ INO+INC	FL 680	⊕ INO+INC	/	
B8	Y	slow action	/		/		FL 874	⊕ INC
B9	Y+Y	slow action	FL 979	⊕ 2NC	FL 980	⊕ 2NC	/	
B20	Y+Y+X	slow action	FL 2079	⊕ 2NC+INO	FL 2080	⊕ 2NC+INO	/	
B21	Y+Y+Y	slow action	FL 2179	⊕ 3NC	FL 2180	⊕ 3NC	/	
B22	Y+X+X	slow action	FL 2279	⊕ INC+2NO	FL 2280	⊕ INC+2NO	/	
B33	Zb	slow action	FL 3379	⊕ INO+INC	FL 3380	⊕ INO+INC	/	
B34	Y+Y	slow action	FL 3479	⊕ 2NC	FL 3480	⊕ 2NC	/	
Min. force			Initial 63 N ... final 83 N (90 N)		Initial 147 N ... final 235 N (250 N)		Initial 63 N ... final 83 N (90 N)	
Travel diagrams			page 190 - group 1		page 190 - group 2		page 190 - group 3	

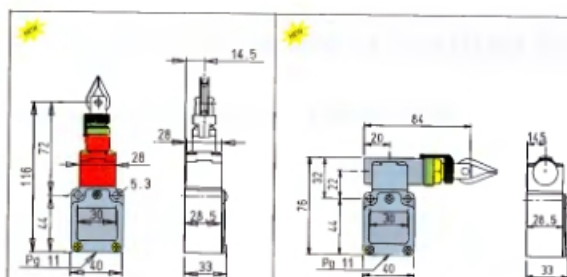

B33 _{Zb}	slow action	FC 3379 \oplus INO+INC	FC 3380 \oplus INO+INC
B34 _{Y+Y}	slow action	FC 3479 \oplus 2NC	FC 3480 \oplus 2NC
Min. force		Initial 63 N ... final 83 N (90 N)	Initial 147 N ... final 235 N (250 N)
Travel diagrams		page 190 - group 1	page 190 - group 2

Application examples and max. rope length for switches with transverse heads

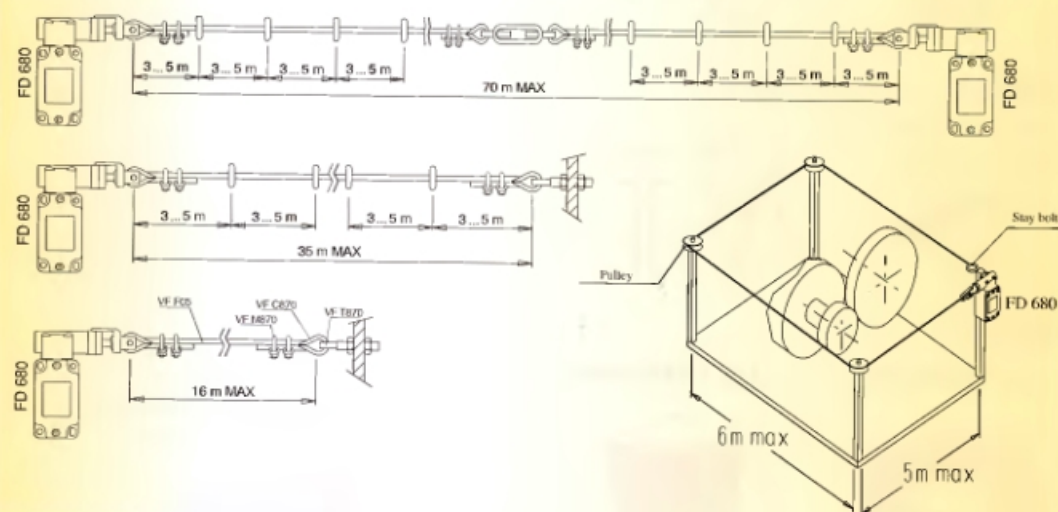

Application examples and max. rope length for switches with longitudinal heads

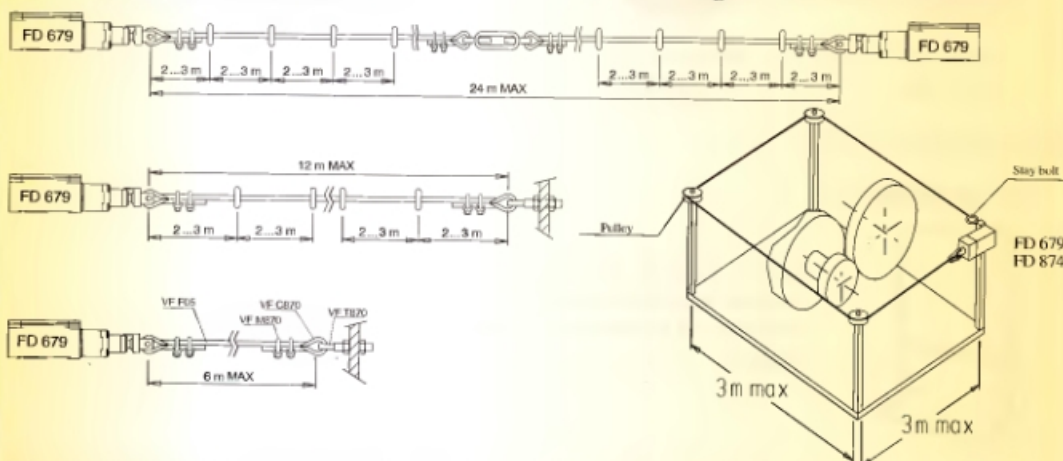

Caution! The indicated max. lengths of the ropes are to be reduced if the room temperature is subject to severe changes.

Markings and quality marks

CE marking

The CE marking is a mandatory declaration made by the manufacturer of a product purpose to indicate that product satisfies all requirements foreseen by the directives (regulated by the **European Community**) on subjects of safety and quality. Its function therefore is to guarantee to the governing authorities of the various countries the fulfilment of their obligations under the law.

IMQ mark

The IMQ (Istituto Italiano del Marchio di Qualità = Italian Institute of the Quality Mark) is the organization in **Italy** (third and independent) whose task is to check and certify the compliance of the materials and the equipments with the safety standards (CEI standard in the electric and electronic branch). This voluntary conformity certification is an achievement that is a guarantee of quality, safety and technical value.

UL mark

UL (Underwriters Laboratories Inc.) is an independent non-profit laboratory that test materials, devices, products, equipment, constructions, methods and systems with regard to their risk for human life and goods according to the standard in force in the **United States**. Regulations and testing made by UL is often taken as valid by many governing authorities regarding conformity with local regulations on the subject of safety.

CSA mark

The CSA (Canadian Standard Association) is an association which has the power to determine whether electrical products comply with the standards of quality and safety required in **Canada**. The majority of the Canadian province's required that all electrical/electronic products manufactured and utilized in Canada, are tested to and comply with the CSA standards.

International, European and Italian standard

IEC 947-5-1 (equivalent with: EN 60947-5-1, CEI EN 60947-5-1 and CEI 17-45) : Low voltage equipments. Section five: devices for control and operation circuits. Section one: electromechanical devices for control circuits.

EN 50041 (equivalent with: CEI 17-31) : Industrial equipments with low voltage. Control accessories. Position switches 42,5x80 mm. Dimensions and features.

EN 50047 (equivalent with: CEI 17-33) : Industrial equipments with low voltage. Control accessories. Position switches 30x55 mm. Dimensions and features.

IEC 204-1 (equivalent with: EN 60204-1 and CEI 44-5) : Electric equipments of industrial machines. Section one. General Standards.

EN 1088 : Interlock devices with or without lock of the guard. Concepts and project.

EN 292 : Machinery safety. Basic concepts and design principles.

IEC 529 (equivalent with: EN 60529 e CEI 70-1): Protection degree of the housings (IP codes).

EN 418 : Machinery safety. Devices for the emergency stop, functional aspects. Design principles

CENELEC EN 50013 : Industrial equipments with voltage lower than 1000 VAC. Location of the clamps.

NFC 63-140 : Control accessories. General prescriptions. (French standard).

BG-GS-ET-15 : Directions for the check of switches with forced opening to be used for safety functions (German standard).

VDE 0660-200 : Control and checking devices. Low voltage control and checking devices. Checking switches. General requirements. (German standard).

VDE 0113 : Specifications for electrical equipments of machines for the production or the manufacturing with rated voltage up to 1000V. (German standard).

UL 508 : Standard for equipments of industrial controls. (American standard).

CSA 22-2 nr.14 : Standard for equipments of industrial controls. (Canadian standard).

Directives:

73/23/EEC Directive on low voltage of electrical equipments.

89/392/EEC Machinery directive.

98/37/EEC - 93/68/EEC Machinery directive updating.

89/336/EEC Electromagnetical compatibility directive.

Actuation methods: slow action contact blocks and snap action contact blocks.

Contact blocks with slow action: component where the speed of the contact depends on the speed with the switch is actuated. The contact armature advances at a rate proportional to the actuation speed.

The slow action block is suitable for those applications requiring the use of low to medium currents and quick actuation movements. It has no differential travel.

Contact block with snap action: component where the speed of the contact doesn't depend on the speed with the switch is actuated. After reaching a predetermined point in travel, the contact armature snaps causing the contacts switch the position.

The snap action block is suitable for those applications requiring the use of high currents and/or slow actuation movements. This kind of contact block has a differential travel.

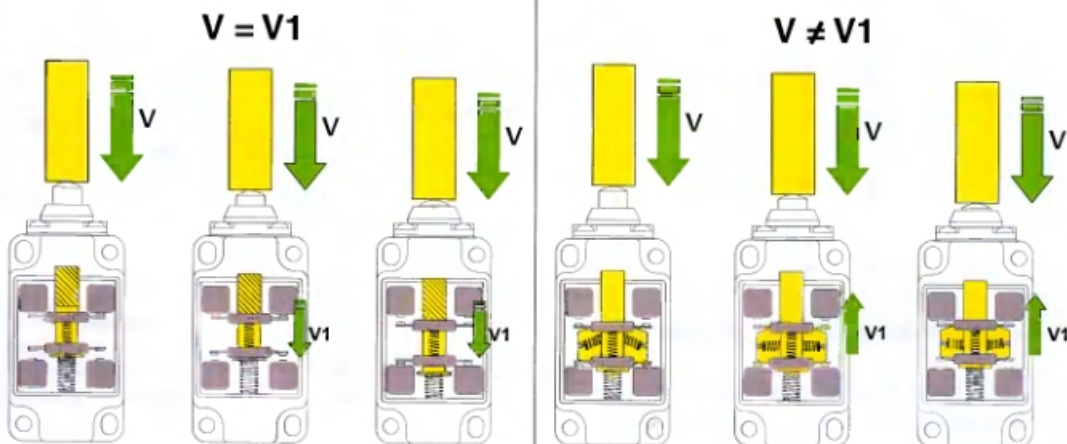

Diagrams of the pressure on the contacts.

The following diagrams show the relationship between of the pressure exerted on the contacts compared to the travel of the armature of the limit switch. You can notice that the pressure on the contact keeps constant in the snap action blocks (1) while approaching to the snap point, while it decreases in the snap action blocks (2). If the application allows it, the contact block which keeps a constant force on the contacts even as the travel varies, is preferable.

(1) Contact blocks B5-B11 snap action

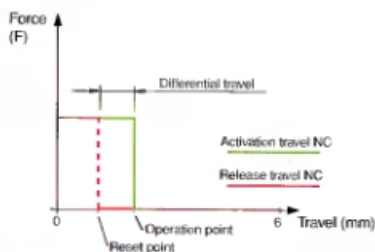

(2) Contact blocks B2-B3 snap action

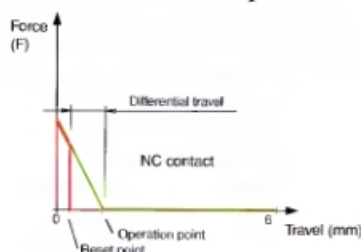

Contact blocks B6-B7-B9-B10-B14-B15-B16-B20-B21-B22-B33-B34 slow action

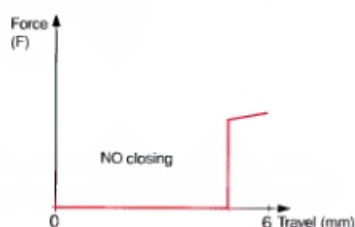
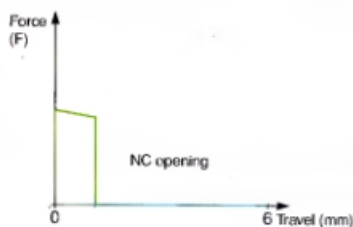
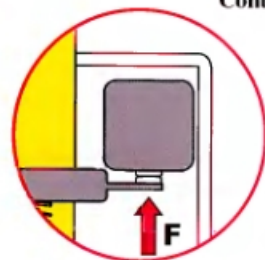

Classification of the contact blocks according to the standard IEC 947-5-1

Form	Figure	Symbol	Description
X			Contact component with double cutoff with two clamps
Y			
C			Shifting contact component with simple cutoff with three clamps.
Za			Shifting contact component with double cutoff with four clamps Contacts have the same polarity
Zb			Shifting contact component with double cutoff with four clamps. Moving contacts are electrically separated

The "+" symbol between the two contact forms (e.g. X+X, Za+Za, X+X+Y, etc.) indicates that those contact blocks maintains **electrical separation** between each other.

The electrically separated contacts **allow** the application of different voltages and polarities between the contacts.

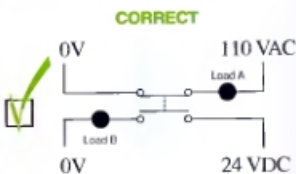

Prescriptions and restrictions for Za contacts:

Electrical loads must be connected to the same phase or polarity. The contacts **are not** electrically separated, so you can not connect different voltages between the NC contact and the NO contact.

Also, as prescribed by the standard IEC 947-5-1 paragraph K.7.1.4.6.1, if you use Za contacts with positive opening for safety applications, the following restrictions have to be adopted:

"If the control accessory has shifting contacts components with form C or Za, **you have to use only one contact component** (closure or cutoff). In case of shifting contact with form Zb, both contacts may be used..."

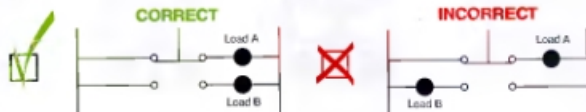

Pollution degree according to the standard IEC 947-1 (of environmental conditions)

According to the standard IEC 947-1, the pollution degree is the conventional number based on the quantity of conducting hygroscopic dust, ionized gas or salt, on the relative humidity and on the frequency of occurrence, which is translated into hygroscopic absorption or humidity condensation, which has the effect of the reduction of the dielectric rigidity and/or surface resistivity. In equipment to be used inside a housing or having an integral enclosure as part of the device, the pollution degree applies to the inner moist housing. For the purpose of evaluation of the insulation distances in air and on surface, the following four pollution degrees are settled:

Degree	Description
1	No pollution or just dry and non-conductive pollution present
2	Normally the only presence of a non-conductive pollution, occasionally may occur some temporary conductivity caused by the condensation.
3	Some conductive pollution, or some dry non-conductive pollution occurs, but it becomes conductive because of the condensation.
4	Pollution causes persistent conductivity for instance because of conductive dust or rain or snow.

Where not otherwise specified by the applicable standard for the product, equipments for industrial applications are generally intended for their use in ambients with pollution degree 3. Nevertheless other degrees can be considered depending on the environment or on the particular applications.

Protection degree of the housings for electrical material according to the standard IEC 529.

First number	Description	Meaning of the level of protection for the machine	Meaning of the level of protection for the people	Second number	Description	Meaning of the level of protection for the machine
0		No protection	No protection	0		No protection
1		Protected from a hand or material that is as large as 50 mm in diameter	Not accessible to hazardous parts with back of the hands. ($\phi \geq 50 \text{ mm}$)	1		Protected from drops of water that falls vertically
2		Protected from a finger or material that is as large as 12 mm in diameter	Not accessible to hazardous parts with a finger. ($\phi \geq 12 \text{ mm}$)	2		Protected from drops of water that falls from 15° max.
3		Protected from a tool or material that is as large as 2.5 mm in diameter	Not accessible to hazardous parts with tool ($\phi \geq 2.5 \text{ mm}$)	3		Protected from sprayed water that falls from 60° max.
4		Protected from a wire or material that is as large as 1 mm in diameter	Not accessible to hazardous parts with wire ($\phi \geq 1 \text{ mm}$)	4		Protected from splashes of water around it
5		Protected from dust or wire that does not endanger the safety of the product	Not accessible to hazardous parts with wire ($\phi \geq 1 \text{ mm}$)	5		Protected from jets of water discharged around it
6		Totally protected from dust or wire that does not endanger the safety of the product	Not accessible to hazardous parts with wire ($\phi \geq 1 \text{ mm}$)	6		Protected from strong jets of water around it
				7		Protected from temporary water immersion
				8		Protected from continuous water immersion

This table indicates the protection degrees according to the standards IEC 529, EN 60529, CEI 70-1.

The degrees are identified by the letters IP and two numbers. Two more letters can be added, in order to give the protection degree for people or other features.

The first number means the degree of protection against penetration of external solids materials.

The second one indicates the degree of protection against penetration of water.

Housing features according with UL approvals (standard UL 508) and CSA approvals (C22-2 nr.14).

The features required for an housing are determined by a specific environmental designation and other features like the kind of gasket or the use of solvent materials.

Kind Use guidance and description

- 1 Mainly for indoor utilization, supplied with protection from contact with the internal mechanism and against a limited quantity of falling dirt.
- 4X Both indoor and open-air utilization, supplied with a protection degree against falling rain, sprinkling of water and direct water from the pipe. It is not damaged by the frosting of the housing and it is rust-proof. It is not damaged by corrosion.
- 12 Indoor utilization, supplied with a protection degree against dust, dirt, flying fibers, dripping water and outside condensation of non-corrosive fluids.
- 13 Indoor utilization, supplied with a protection degree against dust, dust penetration, outside condensation and sprinkling of water, oil and non-corrosive fluids.



 **pizzato elettrica** ... *Passion for Quality*

Pizzato Elettrica s.r.l. Via Anconetta 70 - 36063 Marostica (VI) ITALY

Telephone ++39.0424.470.930 - Telefax ++39.0424.470.955

E-mail info@pizzato.com - Web site www.pizzato.com

