



| Sensing Distance | | | Amplifiers |
|------------------|--|--|--|
| | | | E3S-X3, E3X, E3XA, E3A2-X, E3XR, E3C-X |

Fiber-optic Cables

E32

Extensive Selection of Fiber-optic Sensing Heads Offers Many Unique Solutions for Tough Problems

- Fiber-optic sensors detect small, fast-moving objects in space-confined installations and harsh environments
- For a custom fit in the field, most plastic filament cables can be cut to length
- For detection in hard-to-reach places, sensing heads with bendable stainless steel tubing retain complex shapes
- Coiled and ultra-flexible cables are ideal for flexing and reciprocating machinery such as robots
- *Periscope* sensing heads or accessories save space in right angle detection
- Convergent beam sensing heads allow accurate positioning, even for shiny objects
- Narrow detection zone of concentric beam sensing heads helps eliminate background objects and gives consistent sensing, regardless of object direction
- Most fiber cables offer IP67 protection and temperature ratings of -40°C to 70°C (-40°F to 158°F)

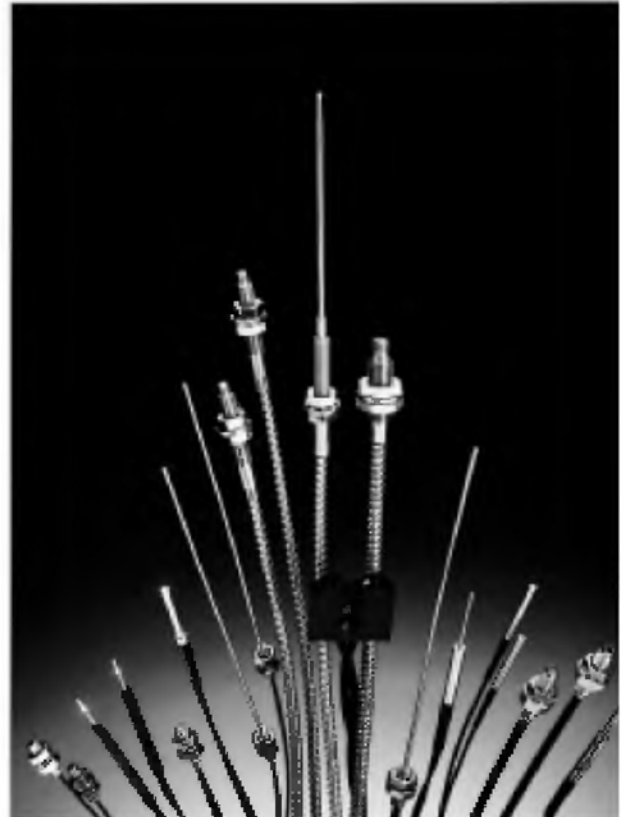

Application Examples

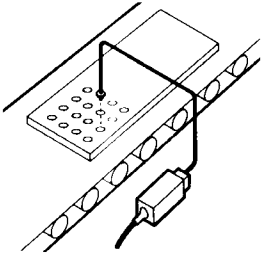
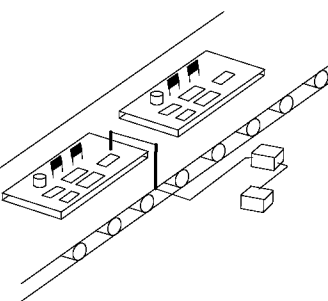
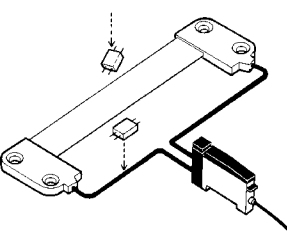
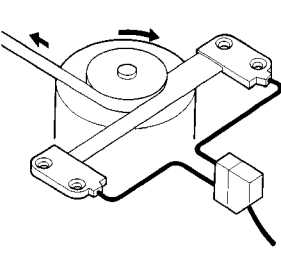
| | | | |
|---|---|---|--|
| Detect small holes in machine parts | Detecting presence of printed circuit board components | Detects metal or non-metal chips within a sensing area as large as 2 x 11-mm | Detects when tape roll has reached selected diameter |
|  |  |  <p>Chips need not be in a straight line.</p> <p>Sensor, used vertically, will detect object as tiny as 1.3 mm.</p> |  <p>Outputs a signal when selected diameter is reached.</p> |

Ordering Information

■ THROUGH-BEAM TYPE

General Purpose

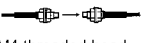
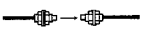
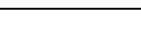
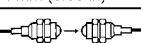
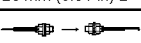
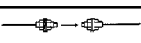
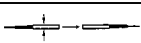
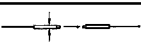
| Part Number | Appearance | Cable Length | Sensing Distance | Minimum Object Size | Fiber Material | | Remarks |
|-------------|---|----------------|---|--------------------------------|----------------------------------|--------|---|
| | | | | | Core | Sheath | |
| E32-T11 |  M4 threaded head x 11.7 mm (0.46 in) L | 2 m | 18 cm (7 in) 1 m (3.28 ft) with E39-F1 | 0.5 mm (0.02 in) dia. | PMMA | PE | 1.5 mm ID fiber Ultra flexible cable |
| E32-T11L |  M4 threaded head x 11.7 mm (0.46 in) L | | 35 cm (13.8 in) 1 m (3.28 ft) with E39-F1 lens kit | | | | 1.4 mm ID fiber |
| E32-T12L |  3 mm dia. (0.12 in) x 14 mm (0.55 in) | | 35 cm (13.8 in) | | | | 1 mm ID fiber |
| E32-T17L |  M4 threaded head x 23 mm (0.91 in) L | 10 m | 7 m (23 ft) | 1 mm ID fiber Long distance | | | |
| E32-T21 |  M3 threaded head x 11 mm (0.43 in) L | 2 m | 5 cm (1.97 in) | 0.2 mm (0.01 in) dia. | Plastic extra flexible | PE | 0.5 mm ID fiber Ultra flexible cable |
| E32-T21L |  M3 threaded head x 9 mm (0.35 in) L | | 10 cm (3.94 in) | | | | 0.5 mm ID fiber |
| E32-T22 |  2 mm dia. (0.8 in) x 22 mm (0.87 in) | | 5 cm (2 in) | | 0.5 mm ID fiber Easy to align | | |
| E32-T22L |  2 mm dia. (0.8 in) x 22 mm (0.87 in) | | 10 cm (3.94 in) | | 0.5 mm ID fiber | | |
| E32-TC50 | M4 threaded head x 14 mm (0.55 in) L | 50 cm (19 in) | 20 cm (7.88 in) | | | | 1 mm ID fiber |
| E32-TC200 | | 2 m (6.4 ft) | 1 m (3.28 ft) with E39-F1 lens kit | | | | Low cost, general purpose |
| E32-TC500 | | 5 m (16.4 ft) | | | | | |
| E32-TC1000 | | 10 m (32.8 ft) | | | | | |

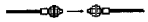
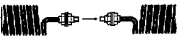
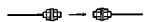

| Part Number | Appearance | Cable Length | Sensing Distance | Minimum Object Size | Fiber Material | | Remarks |
|-------------|--|--------------|---------------------|--------------------------|----------------|--------|----------------------------------|
| | | | | | Core | Sheath | |
| E32-TC200A |  M3 threaded head x 12.5 mm (0.49 in) L | 2 m | 12 cm (4.72 in) | 0.2 mm (0.01 in) dia. | PMMA | PE | 1 mm ID fiber |
| E32-TC200C |  M4 threaded head x 11 mm (0.43 in) L | | | | | | |
| E32-TC200E |  M3 threaded head x 11 mm (0.43 in) L | 2 m | 3.5 cm (1.38 in) | | | | 0.5 mm ID fiber Easy to align |

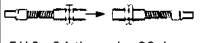
Armored Type

| Part Number | Appearance | Cable Length | Sensing Distance | Minimum Object Size | Fiber Material | | Remarks |
|---------------|---|---------------|--------------------|--------------------------|----------------|--------------------|--|
| | | | | | Core | Sheath | |
| E32-UTAT1-3F |  5/16 - 24 thread x 3.8 mm (1.5 in) L | 0.91 m (3 ft) | 20 cm (7.9 in) | 0.2 mm (0.01 in) dia. | Glass | Stainless steel | General purpose Can withstand temperatures to 150°C (302°F) |
| E32-UTAT1-6F | | 1.83 m (6 ft) | 17 cm (6.7 in) | | | | |
| E32-UTBT1-3F* |  5/16 - 24 thread x 38.1 mm (1.5 in) L | 0.91 m (3 ft) | 40 cm (15.7 in) | 0.25 mm (0.01 in) dia | | | General purpose Can withstand temperatures to 200°C (392°F) |
| E32-UTBT1-6F* | | 1.83 m (6 ft) | | | | | |

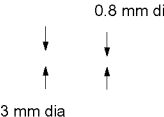
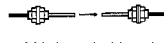

*For use with E3JU-X only

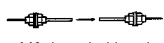
Probe Type

| Part Number | Appearance | Cable Length | Sensing Distance | Minimum Object Size | Fiber Material | | Remarks |
|-------------|---|---------------------------------|--------------------|---------------------------|----------------|--------|---|
| | | | | | Core | Sheath | |
| E32-T33-1 |  0.8 mm dia 3 mm dia | 2 m | 15 mm (0.59 in) | 0.15 mm (0.06 in) dia. | PMMA | PE | 0.25 mm ID fiber Ultra small sensing |
| E32-TC200B |  M4 threaded head | | 18 cm (7 in) | | | | |
| E32-TC200B4 | | | | | | | Probe = 40 mm |
| E32-TC200D |  M4 threaded head | 0.56 m (3.3 m) when extended | 15 cm (5.9 in) | | | | 1 mm ID fiber Probe = 90 mm |
| E32-TC200D4 | | | | | | | Probe = 40 mm |
| E32-TC200F |  M3 threaded head | 2 m | 5 cm (2 in) | | | | 0.5 mm ID fiber Probe = 90 mm |
| E32-TC200F4 | | | | | | | Probe = 40 mm |

THROUGH-BEAM TYPE, CONTINUED

Side Beam Type

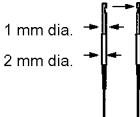
| Part Number | Appearance | Cable Length | Sensing Distance | Minimum Object Size | Fiber Material | | Remarks |
|-------------|---|--------------|------------------|------------------------|----------------|--------|---|
| | | | | | Core | Sheath | |
| E32-T14 |  | 2 m | 90 cm (3 ft) | 0.1 mm (0.004 in) dia. | PMMA | PE | 1 mm ID fiber Built-in lens offers long sensing distance |
| E32-T14L |  | | 12 cm (4.7 in) | | | | 1 mm ID fiber |
| E32-T16 | | | 75 cm (29 in) | --- | | | 1 mm ID fiber includes 0.5 mm and 1.0 mm slit masks |
| E32-T16P |  | | 20 cm (8 in) | --- | | | |
| E32-T24 |  | | 4.5 cm (1.8 in) | 0.1 mm (0.004 in) dia. | | | 0.5 mm ID fiber |

High Temperature Type

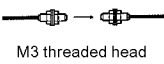
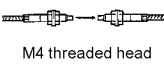



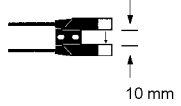
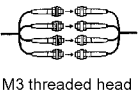
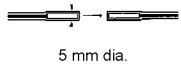
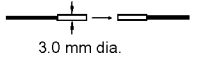
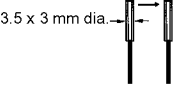
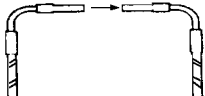





| Part Number | Appearance | Maximum Temperature | Sensing Distance | Minimum Object Size | Fiber Material | | Remarks |
|-------------|---|---------------------|---|-----------------------|----------------|---------|-----------------|
| | | | | | Core | Sheath | |
| E32-T51 |  M3 threaded head | 150°C (302°F) | 15 cm (5.9 in) | 1 mm (0.04 in) dia. | PMMA | PE | 1.5 mm ID fiber |
| E32-T61 |  M4 threaded head | 300°C (572°F) | 15 cm (5.9 in) 1.5 m (4.9 ft) with E39-F1 lens | 0.2 mm (0.01 in) dia. | Glass | SUS 304 | 1 mm ID fiber |

Special Purpose Type

| Part Number | Appearance | Cable Length | Sensing Distance | Minimum Object Size | Fiber Material | | Remarks | |
|-------------|---|--------------|------------------|-----------------------|----------------|--------|---|--|
| | | | | | Core | Sheath | | |
| E32-G14 |  10 mm | 2 m | 10 mm (0.39 in) | 0.5 mm (0.02 in) dia. | PMMA | PE | 1 mm ID fiber Ideal for mark sensing or belt alignment | |
| E32-M21 |  M3 threaded head | | 15 cm (6 in) | 0.3 mm (0.01 in) dia. | | | 0.5 mm ID fiber Use with E3XA-CC4A for shape recognition | |
| E32-T12F |  5 mm dia. | | 60 cm (23.6 in) | 0.9 mm (0.04 in) dia. | | | Teflon® | 1 mm ID fiber Ideal for harsh chemical environments |
| E32-T22S |  3.0 mm dia. | | 500 mm | 0.5 mm (0.02 in) dia. | | | PVC | Ideal for sensing silicon wafers Ultra-narrow beam |
| E32-T24S |  3.5 x 3 mm dia. | | 350 mm | | | | | Side-view Ideal for sensing silicon wafers Ultra-narrow beam |
| E32-T84S |  | | 450-480 mm | 0.3 mm | | | Glass | SUS 304 |

■ DIFFUSE TYPE

General Purpose

| Part Number | Appearance | Cable Length | Sensing Distance | Minimum Object Size | Fiber Material | | Remarks |
|-------------|---|-----------------------------------|--|------------------------------|----------------|-----------------|--|
| | | | | | Core | Sheath | |
| E32-CC200 |  M6 threaded head x 20 mm (0.79 in) L | 2 m | 7.5 cm (3 in) | 0.03 mm (0.001 in) dia. | PMMA | PE | 1 mm ID fiber Concentric beam |
| E32-D11 |  M6 threaded head x 17 mm (0.67 in) L | | 4.5 cm (1.8 in) | | | | 0.25 mm ID fiber Ultra-flexible cable |
| E32-D11L |  M6 threaded head x 17 mm (0.67 in) L | | 10 cm (4 in) | 0.015 mm (0.0006 in) dia. | | | 1 mm ID fiber Long distance |
| E32-D21 |  M3 threaded head x 11 mm (0.43 in) L | | 0.7 cm (0.28 in) | 0.03 mm (0.001 in) dia. | | | 0.25 mm ID fiber Ultra-flexible cable |
| E32-D21L |  M4 threaded head x 12 mm (0.47 in) L | | 2.5 cm (1 in) | | | | 0.5 mm ID fiber |
| E32-D22L |  3 mm (0.12 in) dia. x 15 mm (0.59 in) L | | 2 cm (0.79 in) | 0.04 mm (0.002 in) dia. | | | 0.25 mm ID fiber Concentric beam |
| E32-D32 |  2 mm dia. | | | | | | 4 cm (1.57 in) |
| E32-D32L |  3 mm dia. | | 0.5 m (19 in) 2 m (6.4 ft) 5 m (16.4 ft) 10 m (32.8 ft) | 7.5 cm (3 in) | | | |
| E32-DC50 |  M6 threaded head x 12 mm (0.47 in) L | | | | | | |
| E32-DC200 | | | | | | | |
| E32-DC500 | | | | | | | |
| E32-DC1000 | | | | | | | |
| E32-DC200C |  M6 threaded head x 17 mm (0.67 in) L | 0.64 m 2.49 m when extended | 7.5 cm (3 in) | 0.03 mm (0.001 in) dia. | 1 mm ID fiber | | |
| E32-DC200E |  M3 threaded head x 11 mm (0.43 in) L | 2 m | 1.8 cm (0.71 in) | | | 0.5 mm ID fiber | |



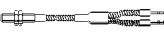
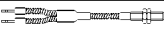

Armored Type

| Part Number | Appearance | Cable Length | Sensing Distance | Minimum Object Size | Fiber Material | | Remarks | | |
|---------------|---|---------------|--------------------|----------------------------|----------------|--------------------|--|--------------------|--|
| | | | | | Core | Sheath | | | |
| E32-UDAT1-3F |  5/16 - 24 thread x 38.1 mm (1.5 in) L | 0.91 m (3 ft) | 8 cm (3.1 in) | 0.03 mm (0.001 in) dia. | Glass | Stainless steel | General purpose Can withstand temperatures to 150°C (302°F) | | |
| E32-UDAT1-6F | | 1.83 m (6 ft) | 6.5 cm (2.6 in) | | | | | | |
| E32-UDBT1-3F* |  5/16 - 24 thread x 38.1 mm (1.5 in) L | 0.91 m (3 ft) | 9 cm (3.5 in) | 0.05 mm. (0.002 in) dia | | | Glass | Stainless steel | General purpose Can withstand temperatures to 200°C (392°F) |
| E32-UDBT1-6F* | | 1.83 m (6 ft) | 8 cm (3.1 in) | | | | | | |

*For use with E3JU-X only

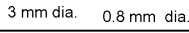
■ DIFFUSE TYPE, CONTINUED

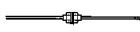

Probe Type

| Part Number | Appearance | Cable Length | Sensing Distance | Minimum Object Size | Fiber Material | | Remarks |
|-------------|---|-----------------------------|------------------|---------------------------|----------------|--------|---|
| | | | | | Core | Sheath | |
| E32-D33 |  3 mm dia. 0.8 mm dia. | 2 m | 5 mm (0.2 in) | 0.015 mm (0.0006 in) dia. | PMMA | PE | 0.25 mm ID fiber Ultra small sensing |
| E32-DC200B |  M6 threaded head | | 7.5 cm (3 in) | | | | 1 mm ID fiber Probe = 90 mm |
| E32-DC200B4 | | | | | | | Probe = 40 mm |
| E32-DC200D |  M6 threaded head | 0.64 m (2.49 when extended) | 2.2 cm (0.87 in) | | | | 1 mm ID fiber Probe = 90 mm |
| E32-DC200D4 | | | | | | | Probe = 40 mm |
| E32-DC200F |  M3 threaded head | 2 m | 1.8 cm (0.71 in) | | | | 0.5 mm ID fiber Probe = 90 mm |
| E32-DC200F4 | | | | | | | |
| E32-DC9G |  | No cable | 3 cm (1.2 in) | | | N/A | 1 mm ID fiber Probe = 90 mm |
| E32-DC9G4 | 1.2 mm dia. | | | | | | |

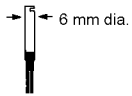
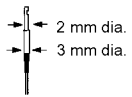

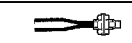

Side Beam Type

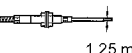
| Part Number | Appearance | Cable Length | Sensing Distance | Minimum Object Size | Fiber Material | | Remarks |
|-------------|---|--------------|------------------|-------------------------|----------------|--------|-----------------|
| | | | | | Core | Sheath | |
| E32-D14L |  6 mm dia. | 2 m | 4 cm (1.6 in) | 0.03 mm (0.001 in) dia. | PMMA | PE | 1 mm ID fiber |
| E32-D24 |  2 mm dia. 3 mm dia. | | 1.5 cm (0.6 in) | | | | 0.5 mm ID fiber |

High Temperature Type

| Part Number | Appearance | Maximum Temperature | Sensing Distance | Minimum Object Size | Fiber Material | | Remarks |
|-------------|--|---------------------|------------------|-------------------------|----------------|---------|-----------------|
| | | | | | Core | Sheath | |
| E32-D51 |  M6 threaded head | 150°C (302°F) | 6 cm (2.4 in) | 0.03 mm (0.001 in) dia. | PMMA | PE | 1.5 mm ID fiber |
| E32-D61 |  M6 threaded head | 300°C (572°F) | 4.5 cm (1.8 in) | | Glass | SUS 304 | 1.4 mm ID fiber |
| E32-D73 |  1.25 mm dia. M4 threaded head | 400°C (752°F) | 3 cm (1.2 in) | | | | 1 mm ID fiber |

Convergent Type and Special Purpose

| Part Number | Appearance | Cable Length | Sensing Distance | Minimum Object Size | Fiber Material | | Remarks |
|-------------|--|--------------|-------------------------------|-----------------------------------|----------------|----------------------------|---|
| | | | | | Core | Sheath | |
| E32-D12F |  6-mm dia. | 2 m | 5 cm (2 in) | 0.03 mm (0.01 in) dia. | PMMA | Teflon® | 1 mm ID fiber Ideal for harsh chemical environ- ments |
| E32-L24L |  | | 4 ±2 mm (0.16 ±0.07 in) | 0.15 mm (0.006 in) dia. | | PE | Side view Convergent beam Ideal for sensing silicon wafers |
| E32-L25 |  | | 3.3 mm (0.13 in) | 0.25 mm (0.01 in) dia. | | | Convergent beam Ideal for sensing silicon wafers |
| E32-L25A |  | | | | | | |
| E32-L25L |  | | | 7.2 ±1.8 mm (0.28 ±0.07 in) | | 0.15 mm (0.006 in) dia. | |

■ RETROREFLECTIVE TYPE

Special Purpose

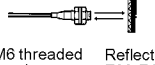
| Part Number | Appearance | Cable Length | Sensing Distance | Minimum Object Size | Fiber Material | | Remarks |
|-------------|--|--------------|--|----------------------------|----------------|--------|---|
| | | | | | Core | Sheath | |
| E32-R16 |  Reflector E39-R1 | 2 m | 15 to 150 cm (5.91 to 59.05 in) with E39-R1 reflector | 0.03 mm (0.001 in) dia. | PMMA | PE | For detection of shiny transparent or opaque objects E39-R1 included |
| E32-R21 |  M6 threaded head Reflector E39-R3 | | 1 to 25 cm (0.39 to 9.84 in) with E39-R3 reflector | | | | For detection of shiny transparent or opaque objects E39-R3 included |

Specifications

■ FIBER UNIT

Through-beam (Separate) Sensors

| Part Number | Operating Ambient Temperature | Operating Ambient Humidity | Permissible Bending Radius | Sheath Material | Enclosure Rating | | | |
|-------------|--|----------------------------|-----------------------------------|--------------------|------------------|----------------|------------|--------------------|
| E32-M21 | -40°C to 70°C (-40°F to 158°F) with no icing | 35% to 85% | 25 mm min. | Black polyethylene | IEC IP67 | | | |
| E32-T11 | | | 4 mm min. | Vinyl chloride | | | | |
| E32-T11L | | | 25 mm min. | Black polyethylene | | | | |
| E32-T12F | 40 mm min. | | Teflon-covered black polyethylene | | | | | |
| E32-T12L | 25 mm min. | | Black polyethylene | | | | | |
| E32-T14 | -40°C to 70°C (-40°F to 158°F) with no icing | | IEC IP50 | 10 mm min. | | Vinyl chloride | | |
| E32-T14L | | | | | | | | |
| E32-T16 | | | | | | | | |
| E32-T16P | | | | | | | | |
| E32-T17L | | | | | IEC IP67 | | | |
| E32-T21 | | | | | | | 4 mm min. | Vinyl chloride |
| E32-T21L | | | | | | | 25 mm min. | Black polyethylene |
| E32-T22 | | | | | | | | |
| E32-T22L | | | | | | | | |
| E32-T24 | | | | | | | | |
| E32-T51 | -40°C to 150°C* (-40°F to 302°F) with no icing | 35 mm min. | Fluoride resin | | | | | |
| E32-T61 | -40°C to 300°C (-40°F to 572°F) with no icing | 25 mm min. | SUS | | | | | |
| E32-TC200 | -40°C to 70°C (-40°F to 158°F) with no icing | | | Black polyethylene | | | | |
| E32-TC200A | | | | | | | | |
| E32-TC200B | | | | | | | | |
| E32-TC200B4 | | | | | | | | |
| E32-TC200C | | | | | | | | |
| E32-TC200D | | | | | | | | |
| E32-TC200D4 | | | | | | | | |
| E32-TC200E | | | | | | | | |
| E32-TC200F | | | | | | | | |
| E32-TC200F4 | | | | | | | | |

*When used continuously between -40°C and 130°C (-40°F and 266°F)

Reflective Sensors

| Part Number | Differential Travel | Operating Ambient Temperature | Operating Ambient Humidity | Permissible Bending Radius | Material | Enclosure Rating | | | |
|-------------|---|---|----------------------------|---|------------------------------------|------------------|---|--------------------|----------------|
| E32-CC200 | 20% of max. detection sensing distance (Adjustable in a range of 0% to 20% when the E3X-H11 is used.) | -40°C to 70°C (-40°F to 158°F) with no icing | 35% to 85% | 25 mm min. | Black polyethylene | IEC IP67 | | | |
| E32-D11 | | | | 4 mm min. | Vinyl chloride | | | | |
| E32-D11L | | | | 25 mm min. | Black polyethylene | | | | |
| E32-D12F | | -30°C to 70°C (-22°F to 158°F) with no icing | | 40 mm min. | Teflon-covered black polyethylene* | | | | |
| E32-D14L | | -40°C to 70°C (-40°F to 158°F) with no icing | | 25 mm min. | Black polyethylene | | | | |
| E32-D21 | | | | 4 mm min. | Vinyl chloride | | | | |
| E32-D21L | | | | 25 mm min. | Black polyethylene | | | | |
| E32-D22L | | | | | | | | | |
| E32-D24 | | | | | | | | | |
| E32-D32 | | | | | | | | | |
| E32-D32L | | | | | | | | | |
| E32-D33 | | | | | | | | | |
| E32-D51 | | | | | | | -40°C to 150°C (-40°F to 302°F) with no icing** | 35 mm min. | Fluoride resin |
| E32-D61 | | | | | | | -40°C to 300°C (-40°F to 572°F) with no icing | 25 mm min. | SUS |
| E32-D73 | | -40°C to 400°C (-40°F to 752°F) with no icing | | | | | | | |
| E32-DC200 | | | | | | | | | |
| E32-DC200B | | | | | | | | | |
| E32-DC200B4 | | | | | | | | | |
| E32-DC200C | | | | | | | | | |
| E32-DC200D | | | | | | | | | |
| E32-DC200D4 | | | | | | | | | |
| E32-DC200E | | | | | | | | | |
| E32-DC200F | | | | | | | | | |
| E32-DC200F4 | | | | | | | | | |
| E32-DC9G | -40°C to 70°C (-40°F to 158°F) with no icing | | | | | | | Black polyethylene | |
| E32-DC9G4 | | | | | | | | | |
| E32-L24L*** | | -40°C to 105°C (-40°F to 221°F) with no icing | | 10 mm min. (average at 10% decrease of sensing distance) | Reinforced polyethylene | IEC IP50 | | | |

*Teflon is a registered trademark of the Dupont Company and the Mitsui Dupont Chemical Company for their fluoride resin.

**When used continuously between -40°C and 130°C (-40°F and 266°F)

***Beam size: 2 mm dia.

| Part Number | Differential Travel | Operating Ambient Temperature | Operating Ambient Humidity | Permissible Bending Radius | Material | Enclosure Rating |
|-------------------|---|---|----------------------------|--|-------------------------|------------------|
| E32-L25 | 20% of max. detection sensing distance (Adjustable in a range of 0% to 20% when the E3X-H11 is used.) | -40°C to 70°C (-40°F to 158°F) with no icing | 35% to 85% | 25 mm min. | Black polyethylene | IEC IP50 |
| E32-L25A | | | | | | |
| E32-L25L*** | | -40°C to 105°C (-40°F to 221°F) with no icing | | 10 mm min. (average at 10% decrease of sensing distance) | Reinforced polyethylene | |
| E32-R16 E39-R1 | | -25°C to 55°C (-13°F to 131°F) with no icing | | 25 mm min. | Black polyethylene | IEC IP66 |
| E32-R21 E39-R3 | -40°C to 70°C (-40°F to 158°F) with no icing | | | | IEC IP67 | |

*Teflon is a registered trademark of the Dupont Company and the Mitsui Dupont Chemical Company for their fluoride resin

**When used continuously between -40°C and 130°C (-40°F and 266°F)

***Beam size: 2 mm dia.

Fine Through-beam Sensors

| Part Number | Beam Size | Differential Travel | Horizontal Positioning Accuracy | Operating Ambient Temperature | Operating Ambient Humidity | Permissible Bending Radius* | Material | Enclosure Rating |
|-------------|--------------------------------------|---------------------|---------------------------------|---|----------------------------|-----------------------------|-------------------------------------|------------------|
| E32-T22S | 13 mm dia. (at a distance of 200 mm) | --- | --- | -40°C to 70°C (-40°F to 158°F) with no icing | 35% to 85% | 10 mm min. | Reinforced laminated vinyl chloride | IEC IP67 |
| E32-T24S | | | | | | | | |
| E32-T84S | | | | -40°C to 200°C (-40°F to 392°F) with no icing | | 25 mm min. | SUS | |

*Average at 30% of sensing distance

Slot Sensors

| Part Number | Operating Ambient Temperature | Operating Ambient Humidity | Permissible Bending Radius | Material | Enclosure Rating |
|-------------|--|----------------------------|----------------------------|--------------------|------------------|
| E32-G14 | -40°C to 70°C (-40°F to 158°F) with no icing | 35% to 85% | 25 mm min. | Black polyethylene | IEC IP67 |

Engineering Data

■ EXCESS GAIN RATIO

Through-beam Type

E32-T22

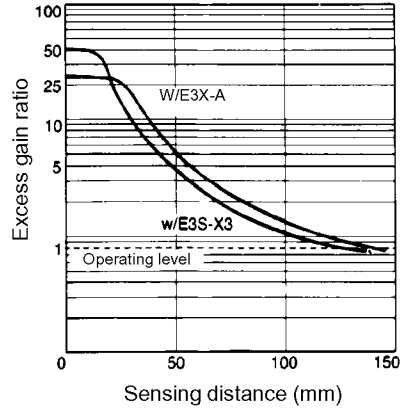

E32-T21L, E32-T22L

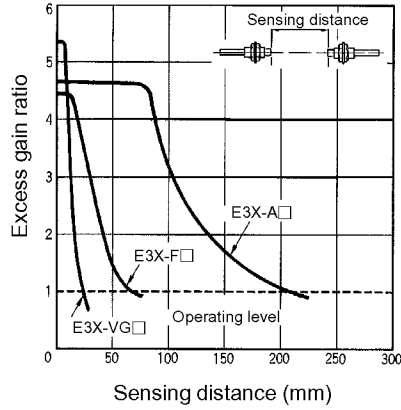

E32-T11L, E32-T12L

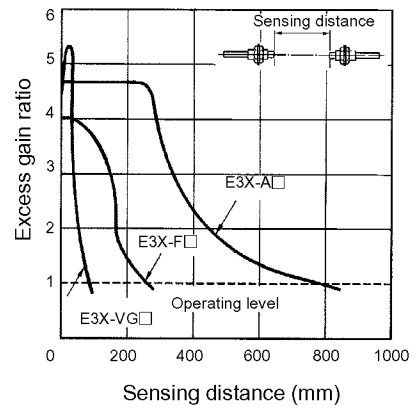

**E32-TC200E, E32-TC200F
E32-TC200F4**

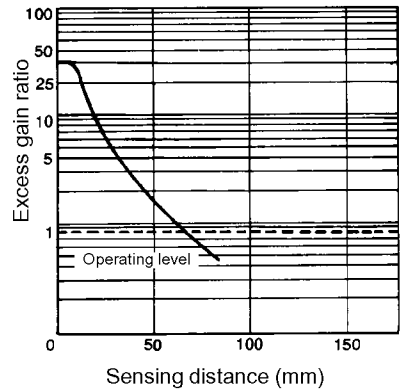

E32-T21

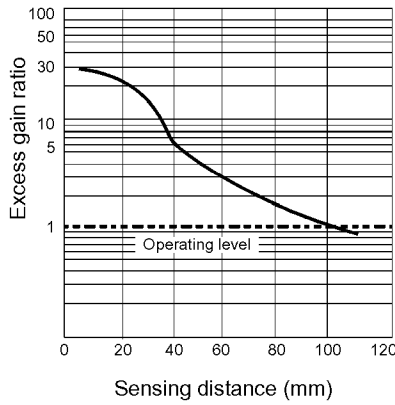

**E32-TC50/200/500/1000, E32-TC200A,
E32-TC200B, E32-TC200B4**

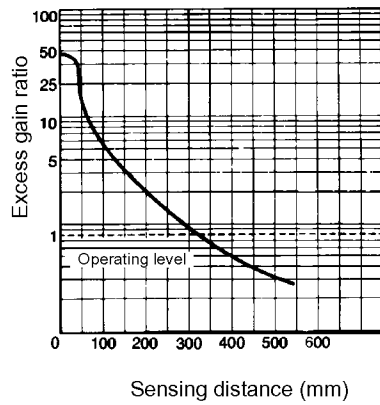

E32-TC200 + E39-F1

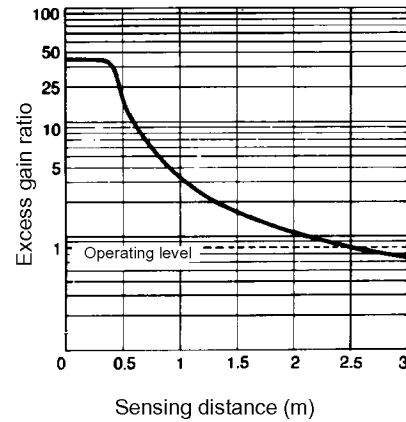

E32-TC200 + E39-F2

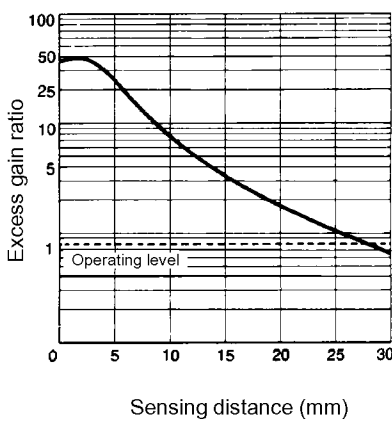

E32-T11

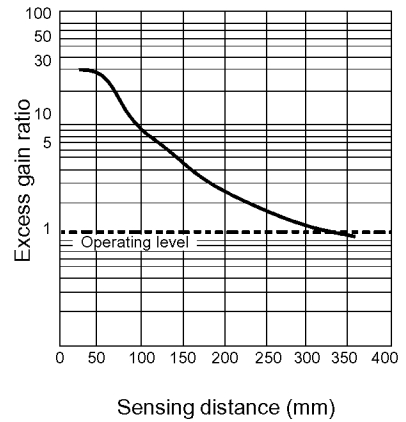

E32-UTAT1-3F

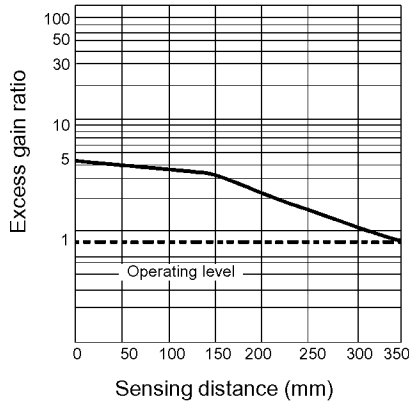

E32-UTAT1-6F

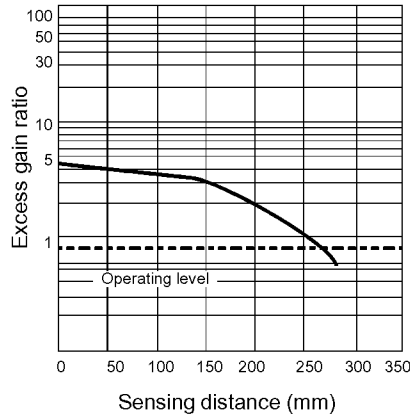

E32-T17L

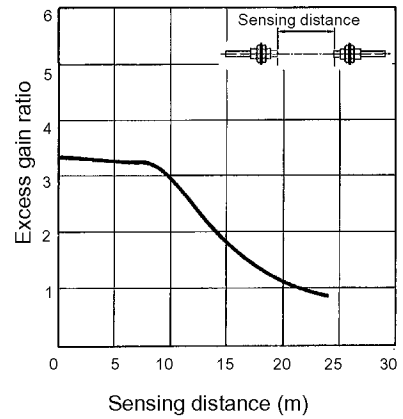

E32-M21

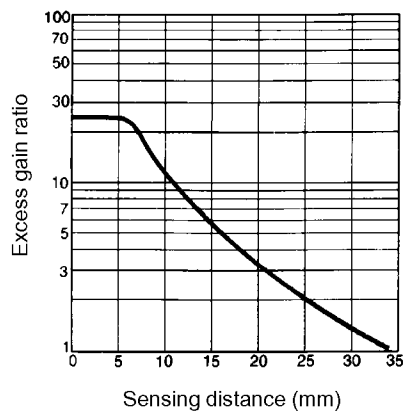

E32-TC200B
E32-TC200B4

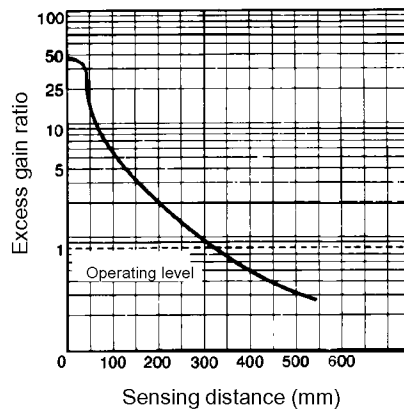

E32-T24

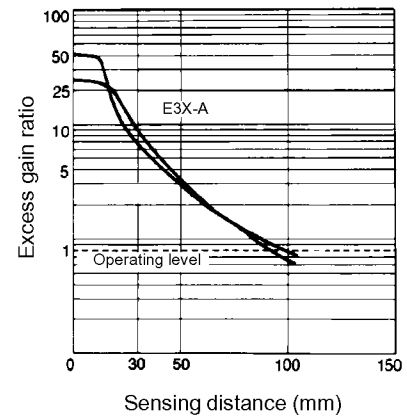

E32-T14L

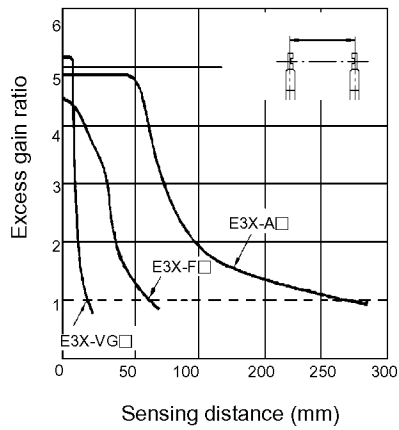

E32-T14

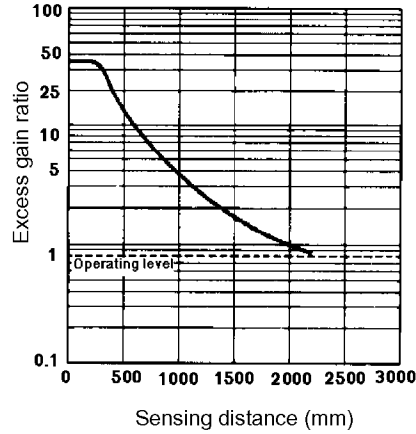

E32-T16

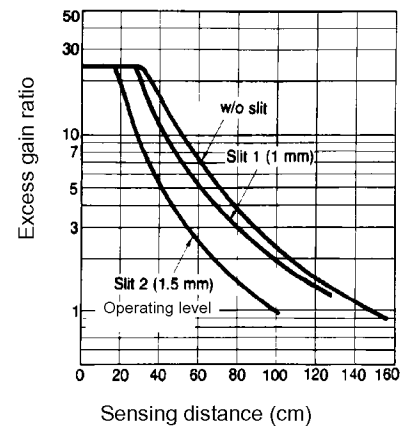

E32-T51

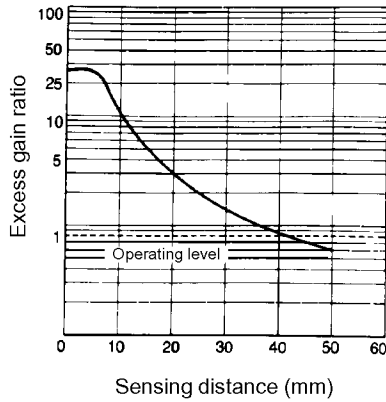

E32-T61

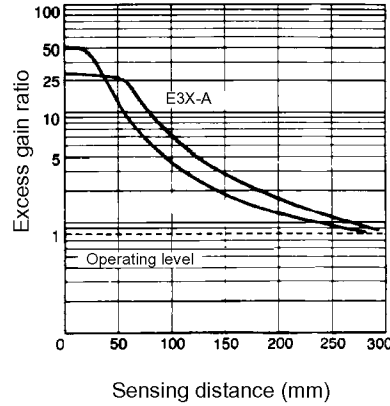

E32-T12F

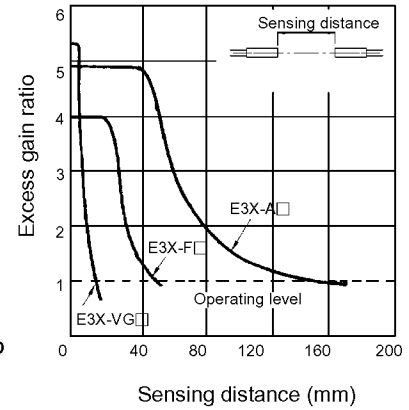

Diffuse Type

E32-D32, E32-DC9G

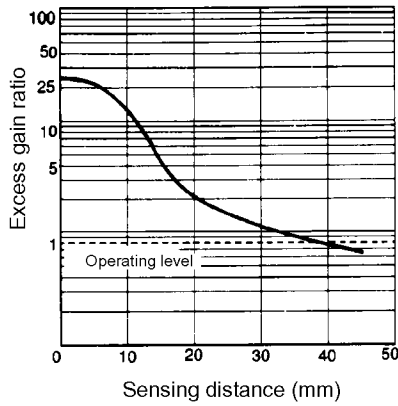

E32-D21L, E32-D22L

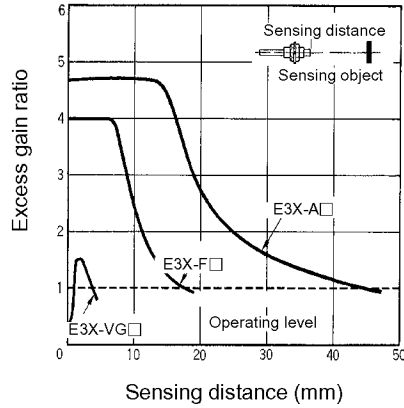

E32-D21

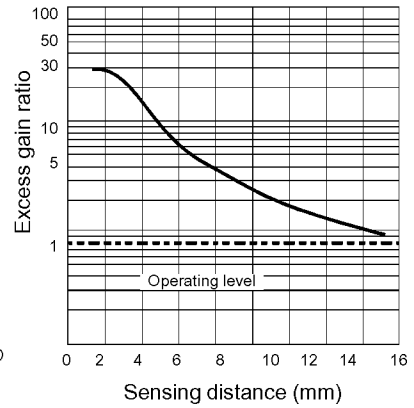

**E32-DC50, E32-DC200,
E32-DC500, E32-DC1000**

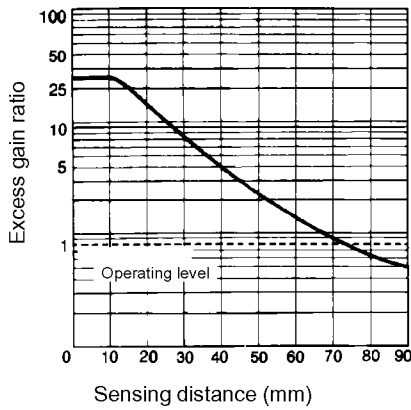

E32-D11

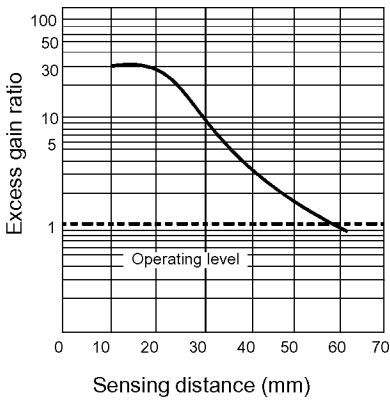

E32-D11L

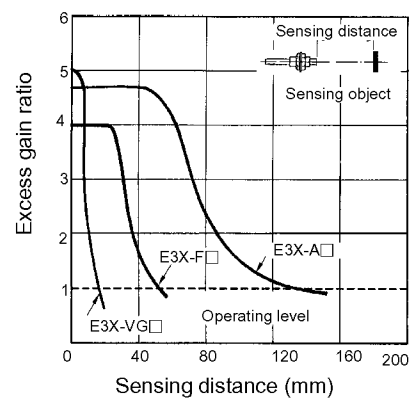

E32-UDAT1-3F

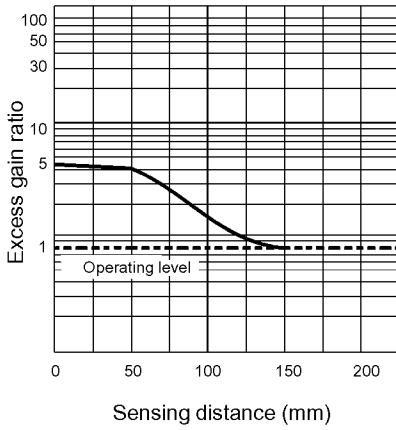

E32-UDAT1-6F

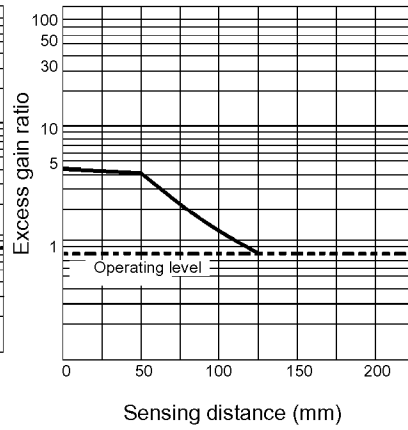

E32-D33

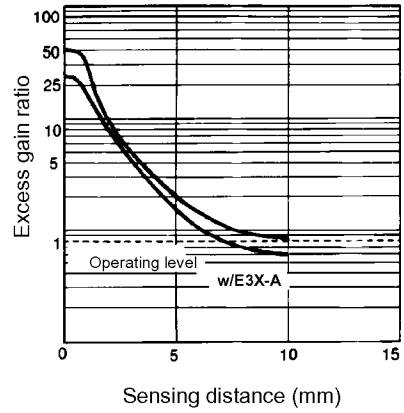

E32-D24

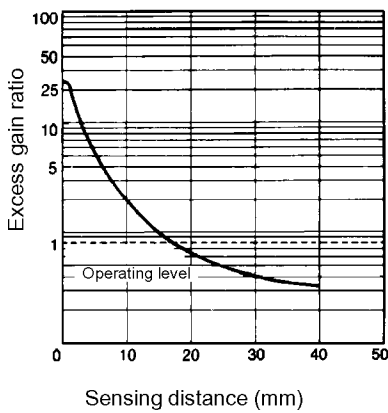

E32-D14L

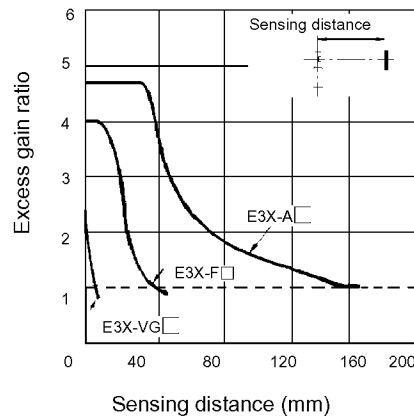

E32-D51

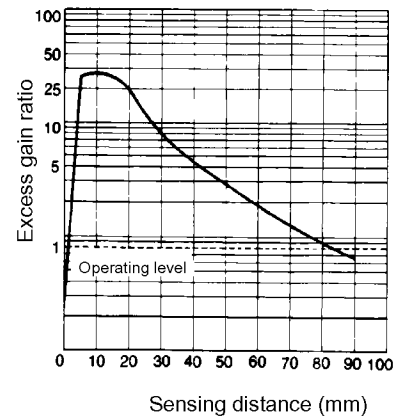

E32-D61

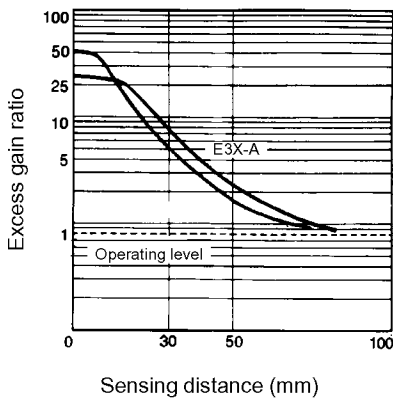

E32-D73

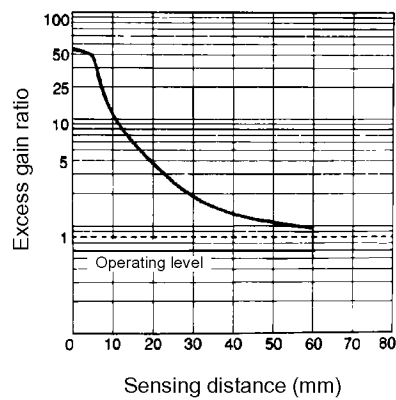

E32-D12F

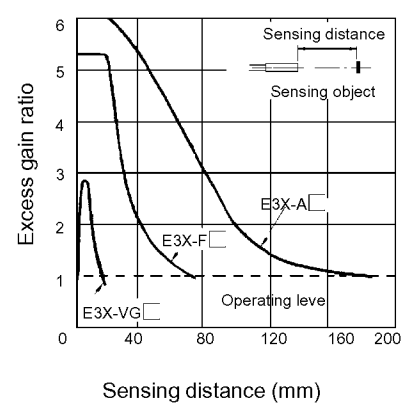

Convergent Type

E32-L25, E32-L25A

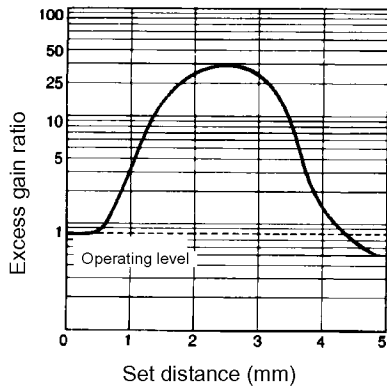

Retroreflective Type

E32-R21

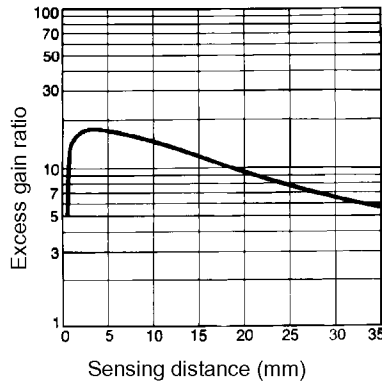

E32-R16

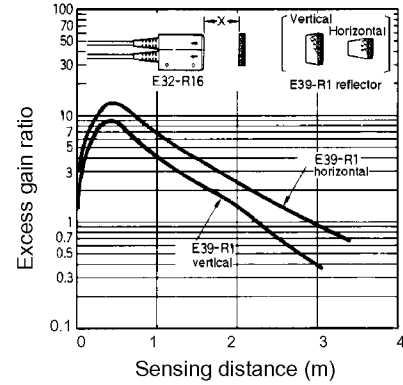

OPERATING RANGE

Through-beam Type

Operating range with E3X-A11 amplifier

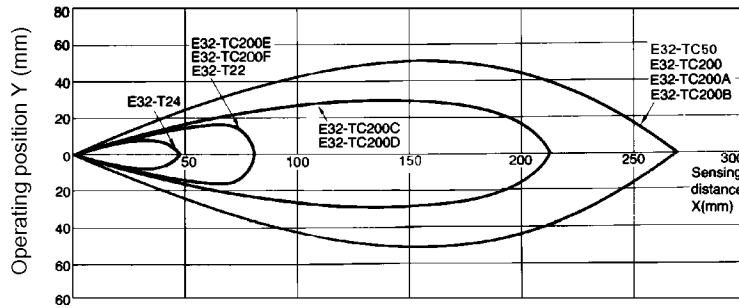

E32-T11L + E39-F3

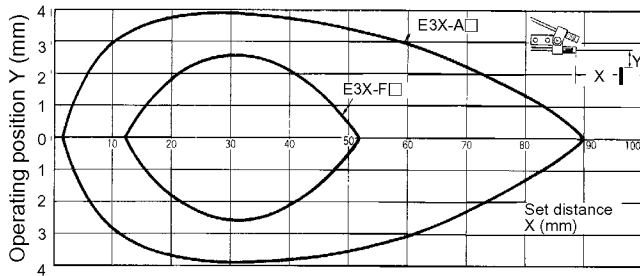

Note: With E3X-A: Adjust the angle of E39-F3 so that the sensor can detect an object at a distance of 90 mm. (For E3X-F: 50 mm).

E32-T22, E32-T24 with E3X-A11 amplifier

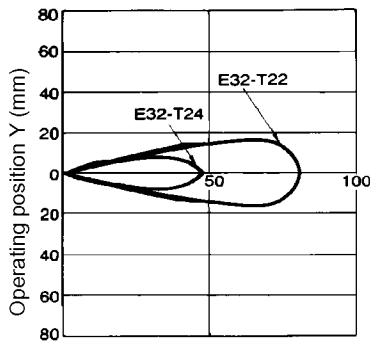

E32-T14 with E3X-A11 amplifier

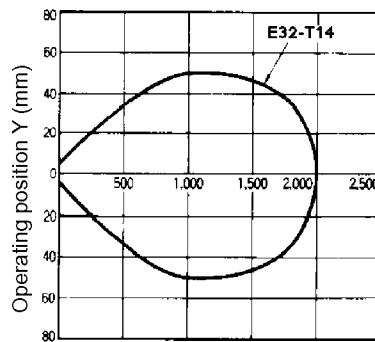

E32-T16 with E3X-A11 amplifier

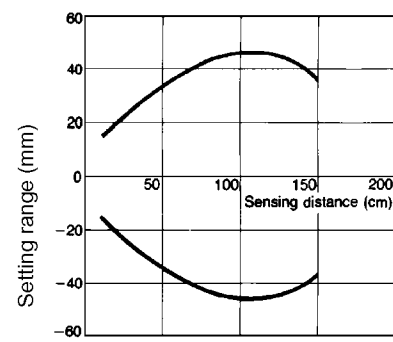

**E32-T51, E32-T61
with E3X-A11 amplifier**

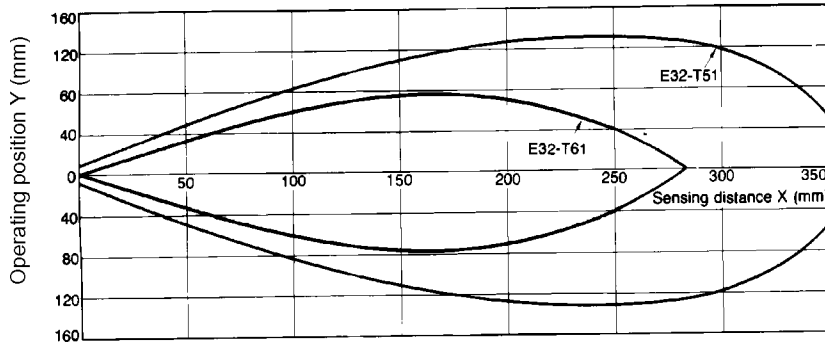

**E32-M21
with E3X-A11 amplifier**

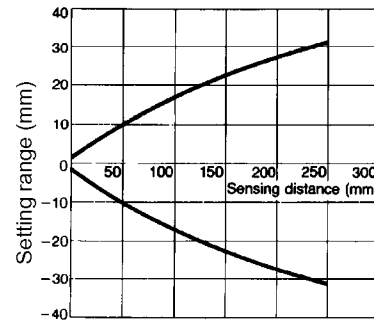

Diffuse Type

E32-D21L, E32-D22L

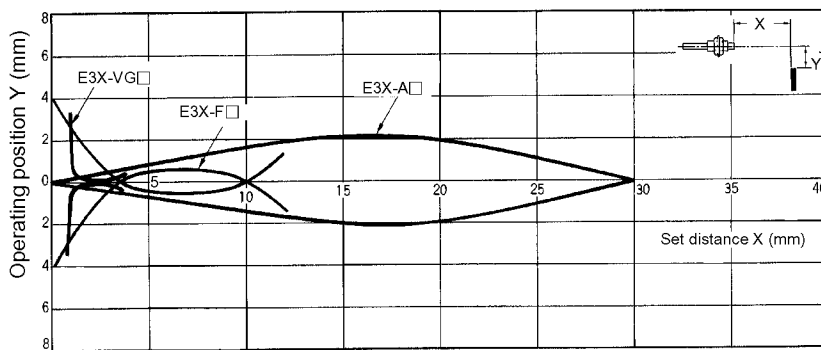

E32-D11L

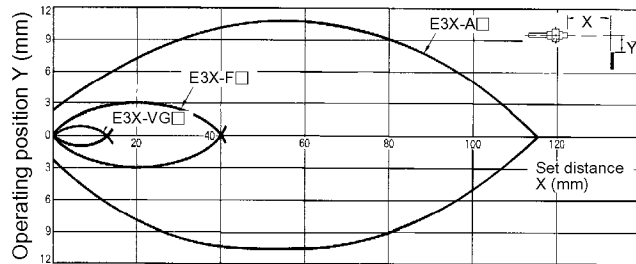

E32-DC200C

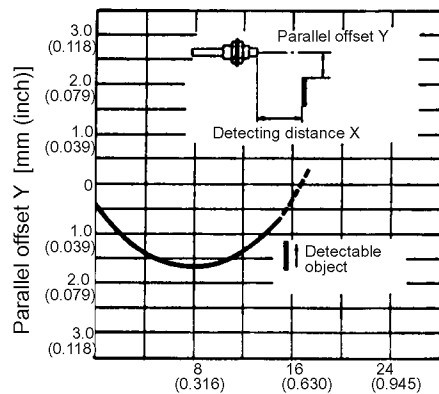

Detecting distance X [mm (inch)] with 5 x 5 cm (2 x 2 in) 90% reflective mat paper

Operating range with E3X-A11 amplifier

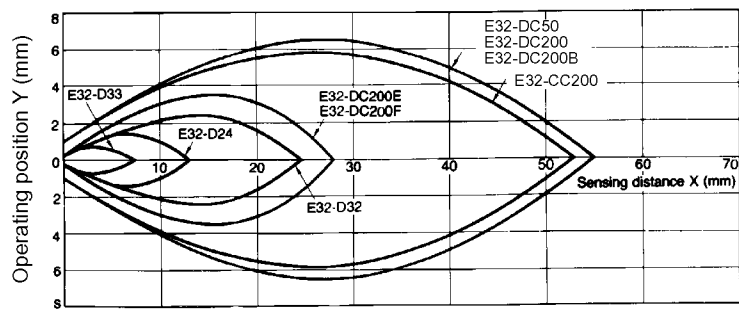

E32-D12F

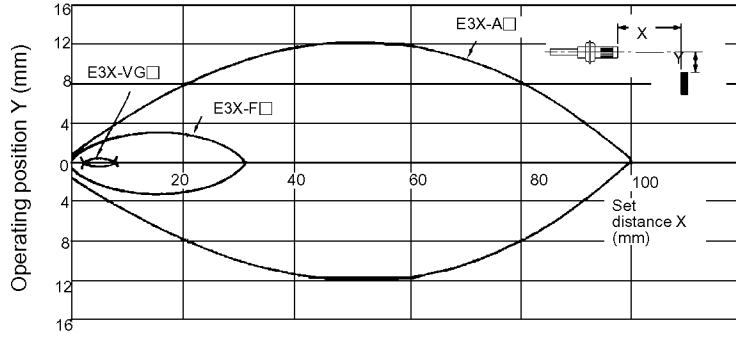

E32-UDAT1-3F with E3X-A amplifier

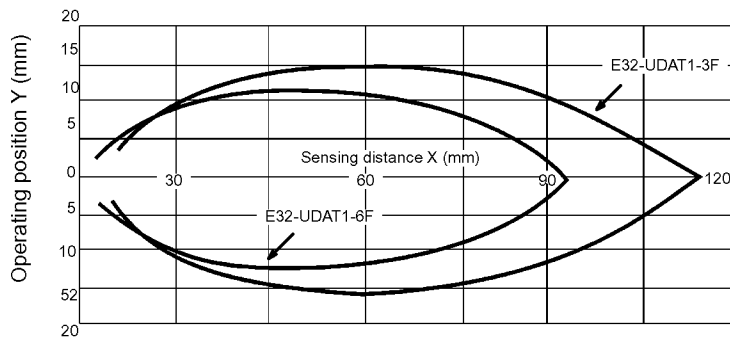

E32-D24, E32-D32, E32-D33

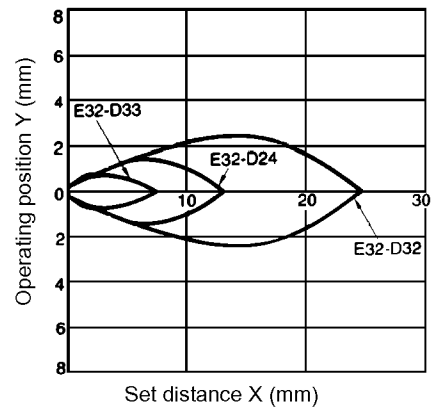

E32-D14L

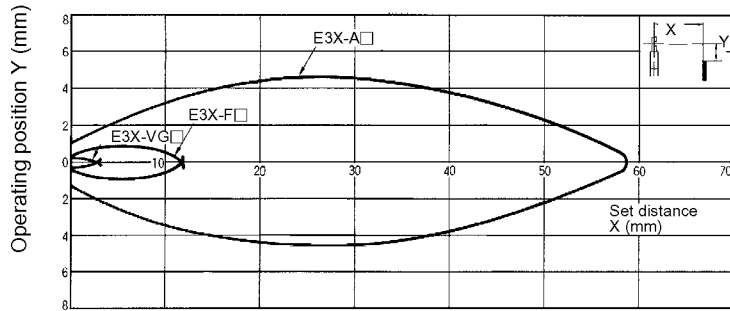

E32-D51, E32-D61, E32-D73

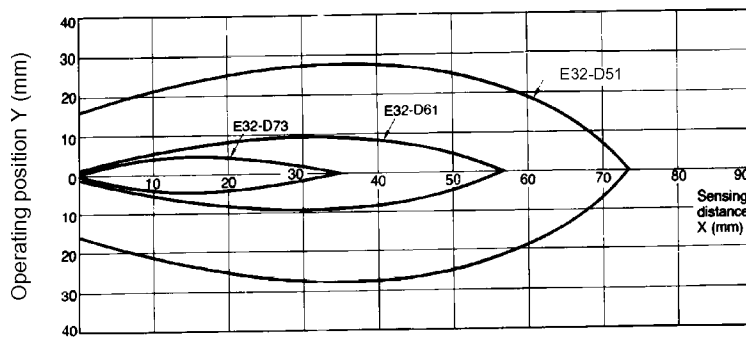

Convergent Type

E32-L25, E32-L25A

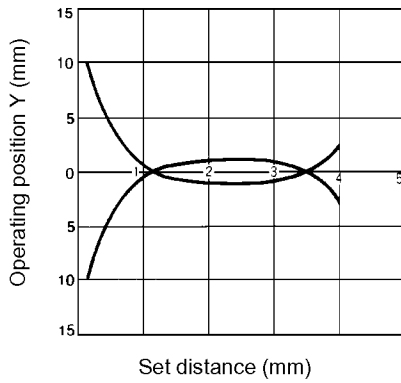

Retroreflective Type

E32-R21 with E3X-A11 amplifier

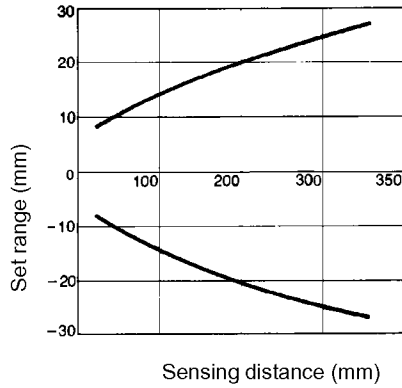

Dimensions

Unit: mm (inch)

**THROUGH-BEAM TYPE
(Sold in pairs)**

General Purpose

E32-T11

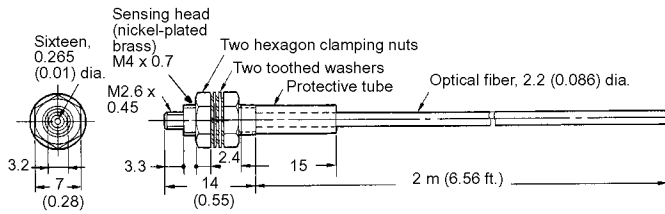

E32-T11L

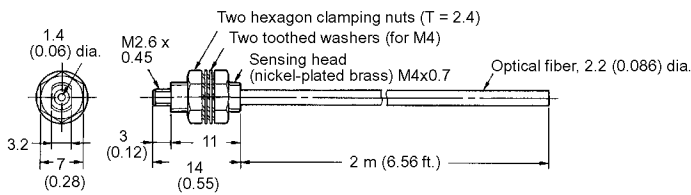

E32-T12L

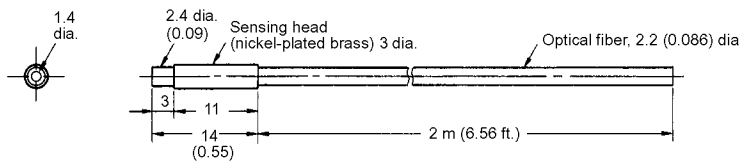

E32-T17L

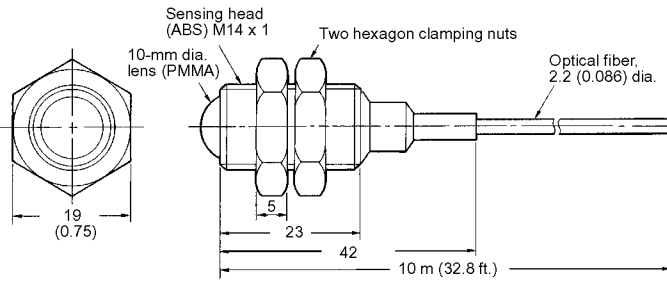

E32-T21

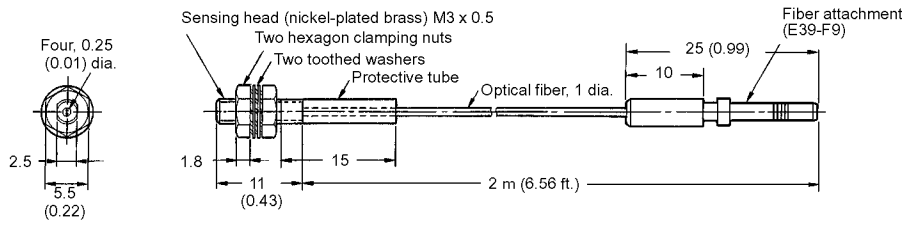

E32-T21L

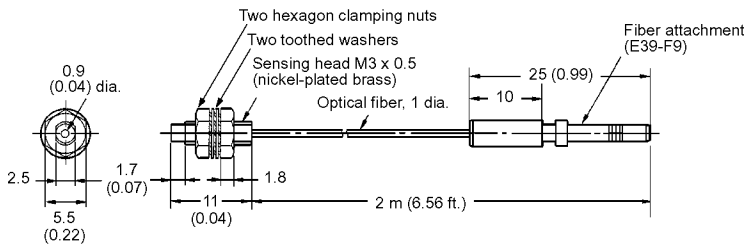

E32-T22

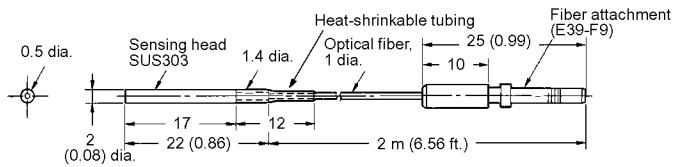

E32-T22L

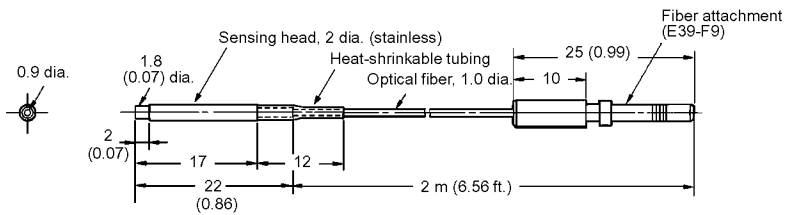

**E32-TC50, E32-TC200, E32-TC500,
E32-TC1000**

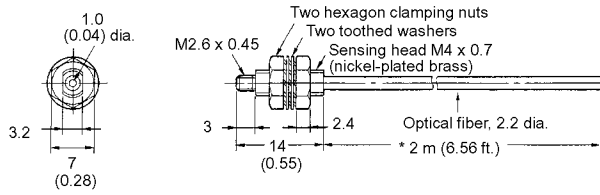

* This length is 50 cm for E32-TC50, 5 m for E32-TC500 and 10 m for E32-TC10000.

E32-TC200A

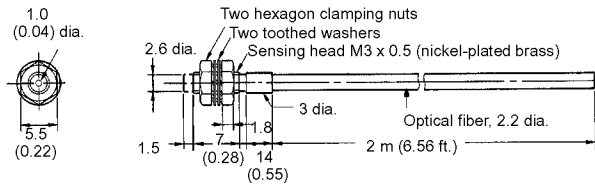

E32-TC200C

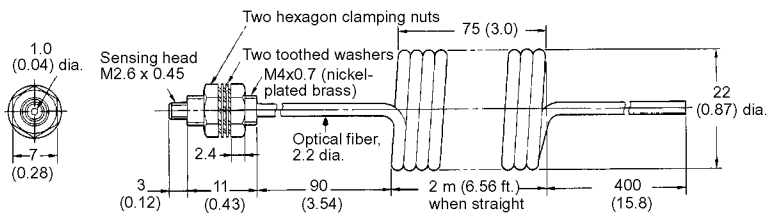

E32-TC200E

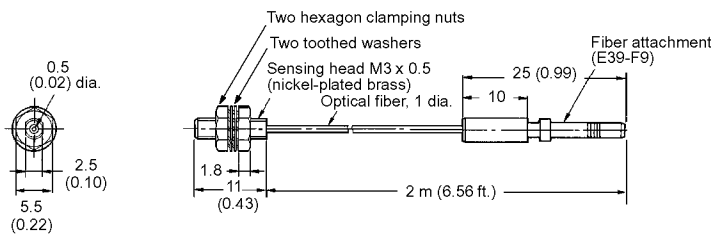

Armored Type

**E32-UTAT1-3F
E32-UTAT1-6F**

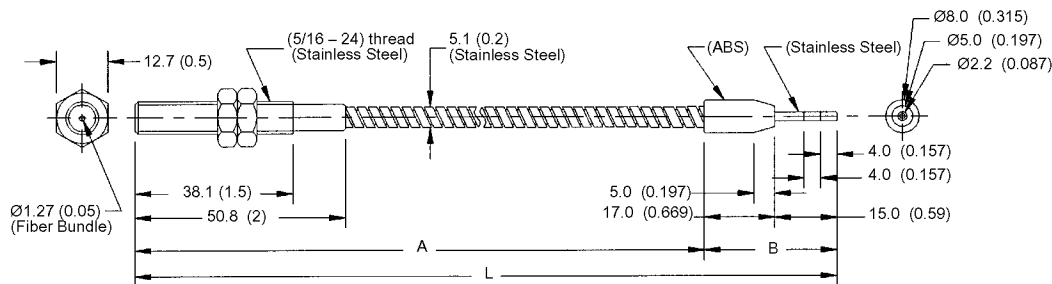

Note: Distance A can withstand 150°C (302°F); Distance B can withstand 70°C (158°F); L=3ft. or 6ft.

E32-UTBT1-3F
E32-UTBT1-6F

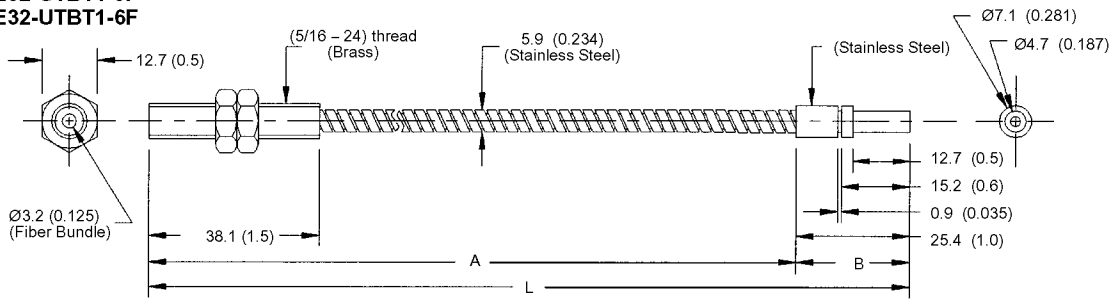

Note: Distance A can withstand 200°C (392°F); Distance B can withstand 70°C (158°F); L=3ft. or 6ft.

Probe Type

E32-T33-1

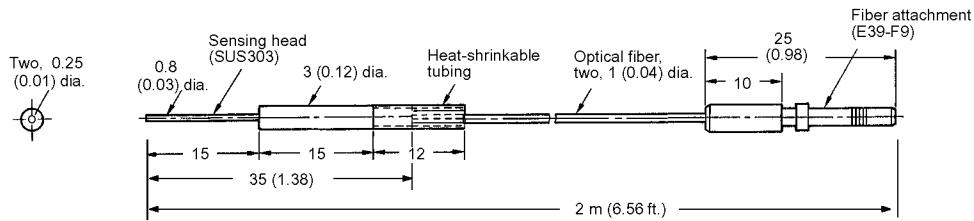

E32-TC200B
E32-TC200B4

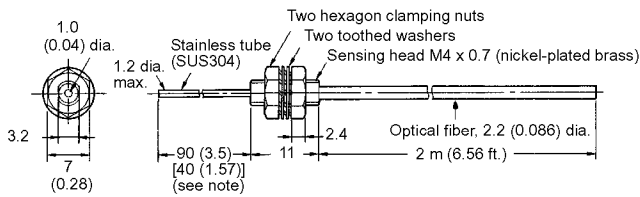

Note: The values in the brackets are for the E32-TC200B4.

E32-TC200D
E32-TC200D4

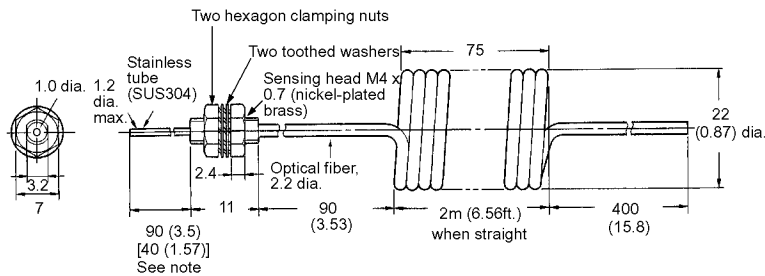

Note: The values in the brackets are for the E32-TC200D4.

E32-TC200F
E32-TC200F4

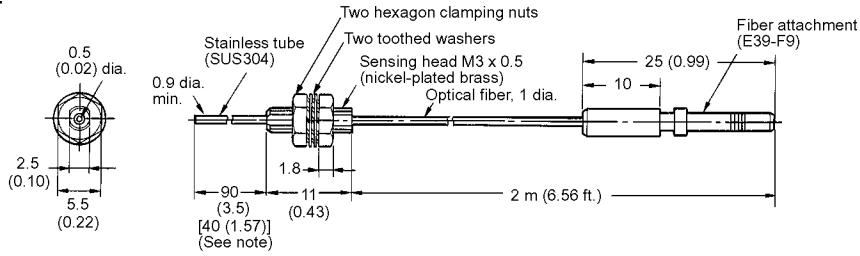

Note: The values in the brackets are for the E32-TC200F4.

Side Beam Type

E32-T14

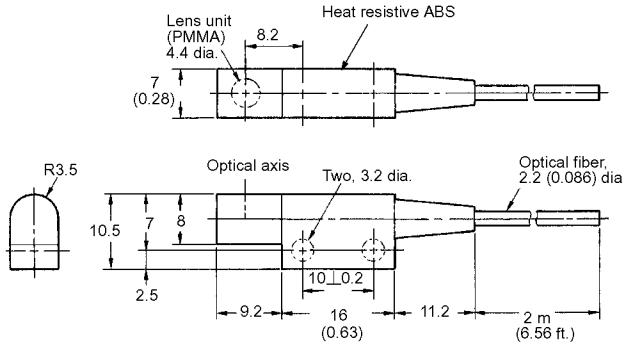

E32-T14L

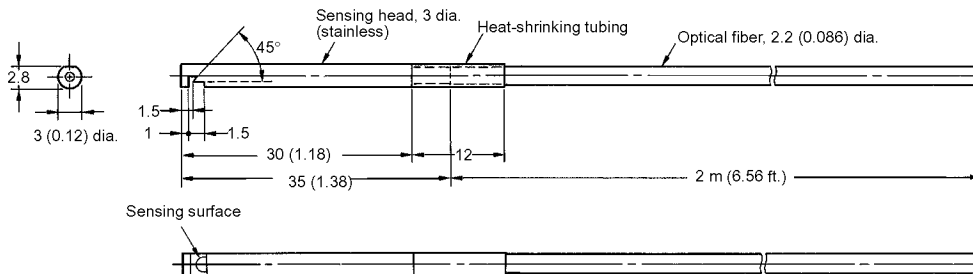

E32-T16

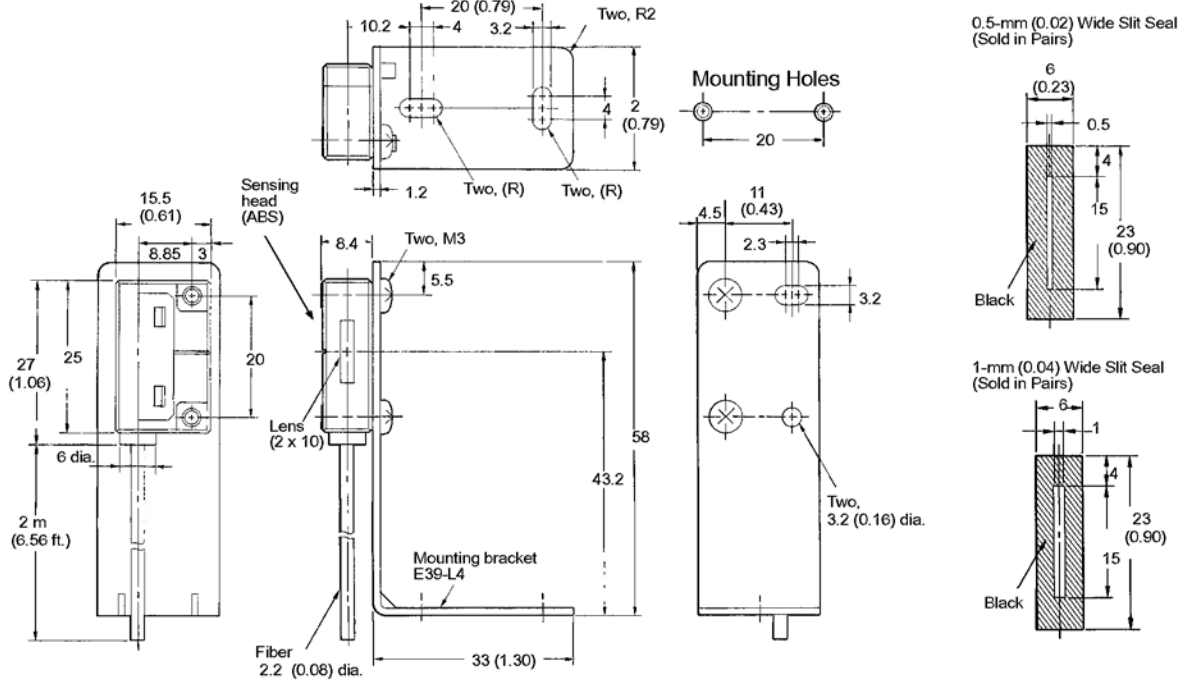

E32-T16P

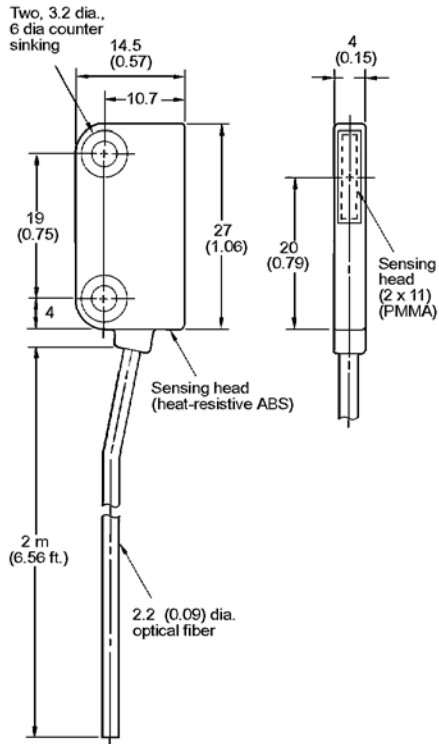

0.5-mm (0.02) wide Seal Slit (Two slits are provided)

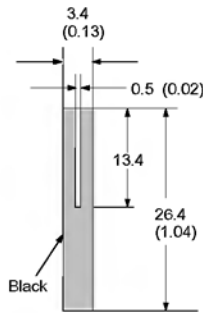

1-mm (0.04) wide Seal Slit (Two slits are provided)

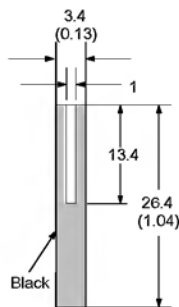

E32-T16P + E39-L94 Mounting

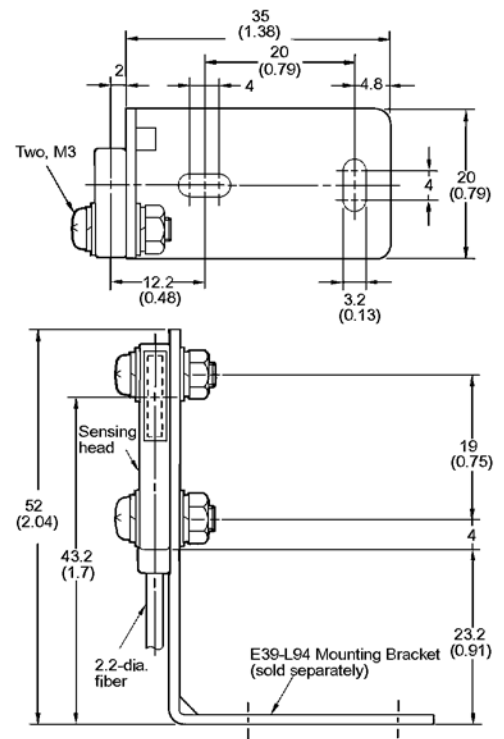

E32-T24

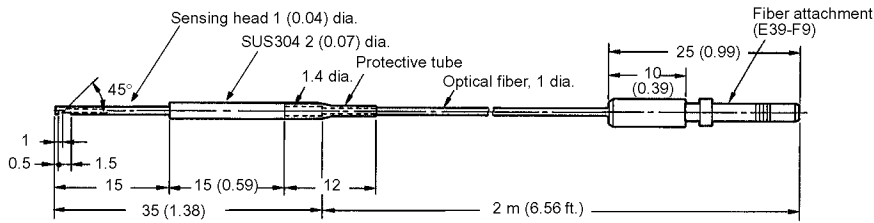

High Temperature Type

E32-T51

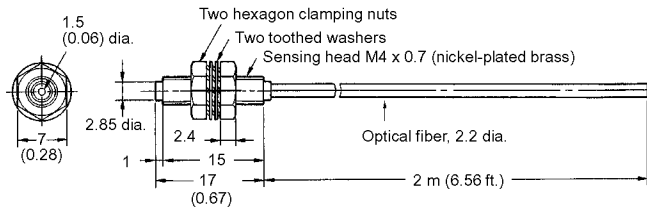

Note: Resistant temperature is 150°C (302°F). Resistant temperature is 130°C (266°F) when used continuously.

E32-T61

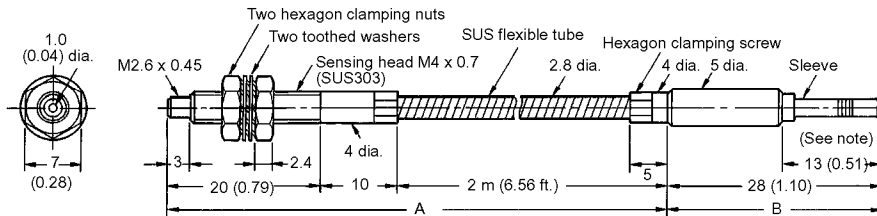

Note: Section A resists 300°C and section B (which is inserted to the amplifier) resists 110°C. The operating temperature of section B must also be within the withstand temperature range of the amplifier.

Special Purpose

E32-G14

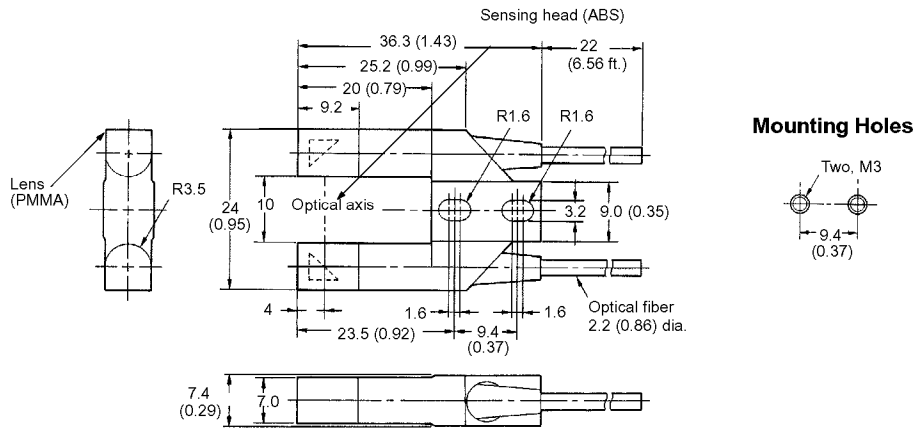

E32-M21

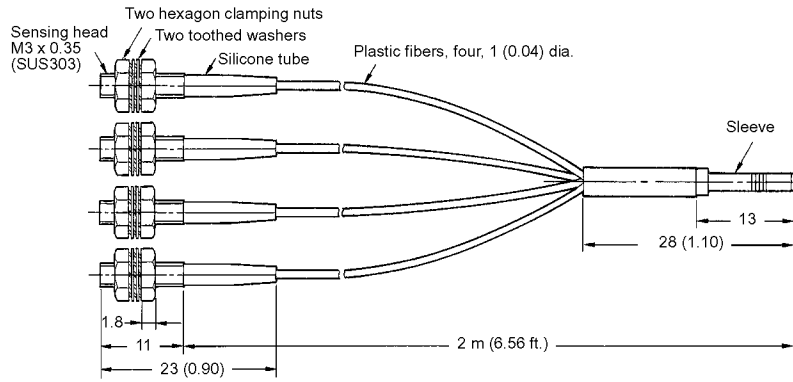

Note: One set of silicone tubes is black while the other set is gray for easy identification when they are connected to the light source and receiver.

E32-T12F

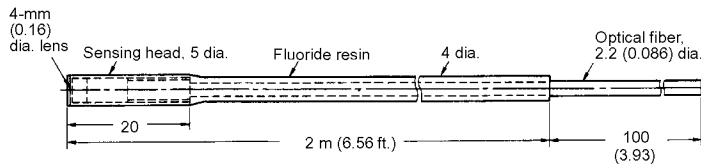

E32-T22S

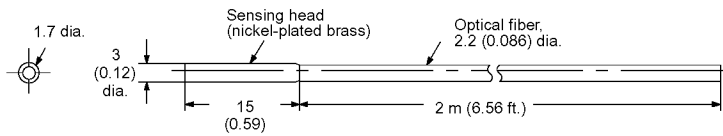

E32-T24S

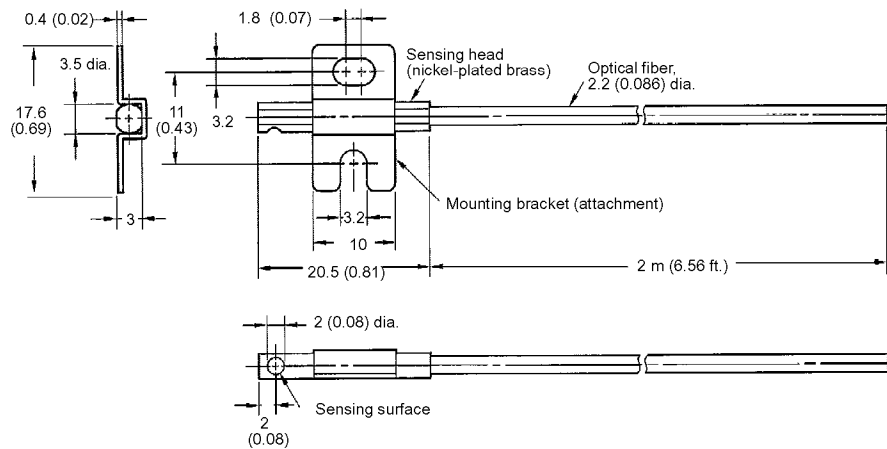

E32-T84S

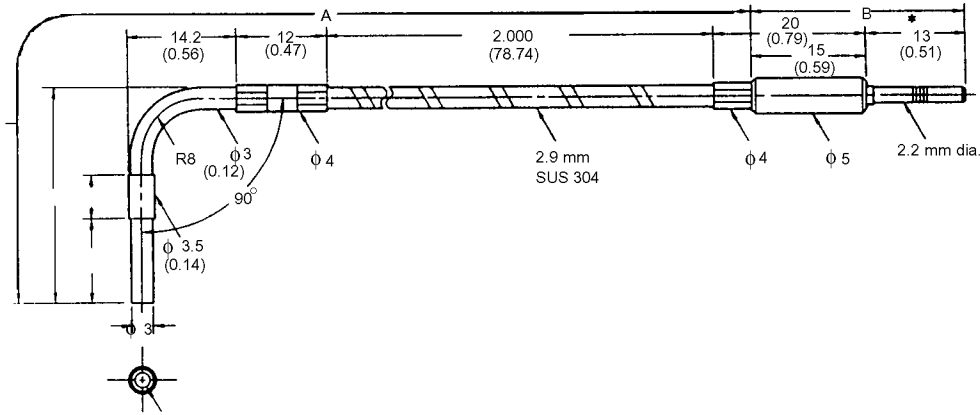

■ DIFFUSE TYPE

General Purpose

E32-CC200

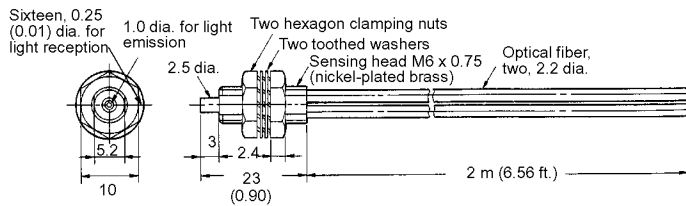

E32-D11

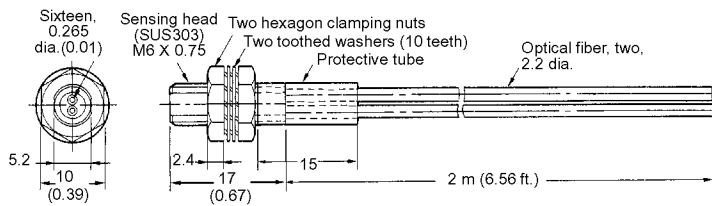

E32-D11L

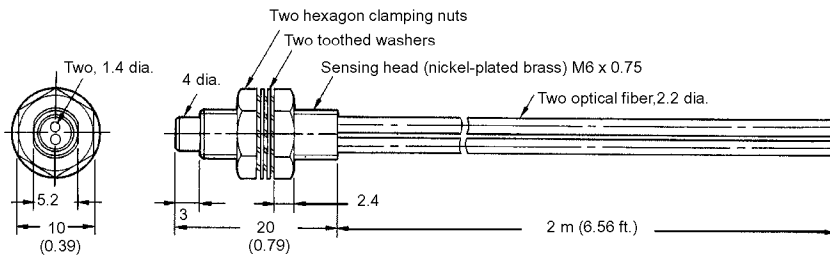

E32-D21

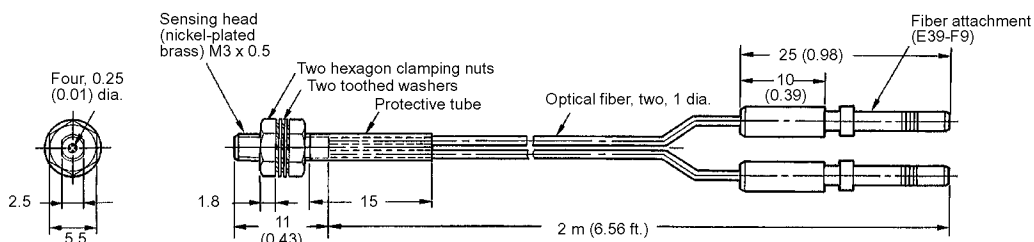

E32-D21L

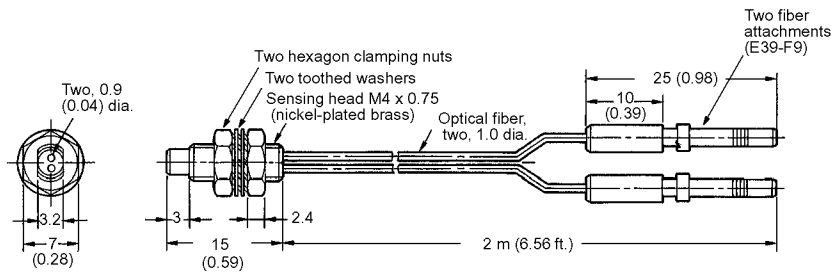

E32-D22L

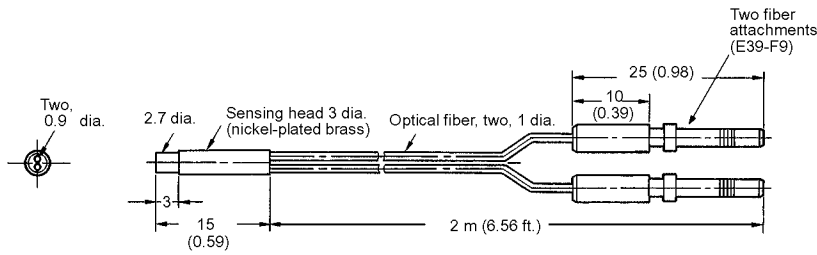

E32-D32

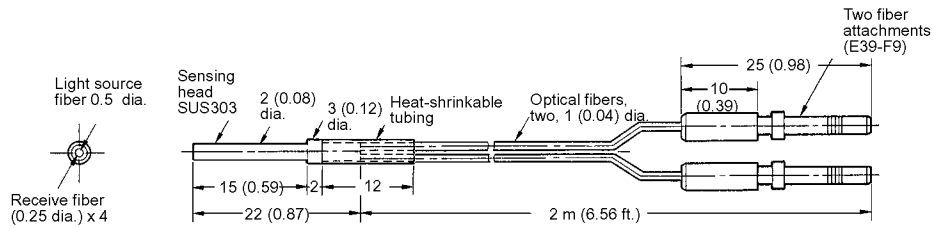

E32-D32L

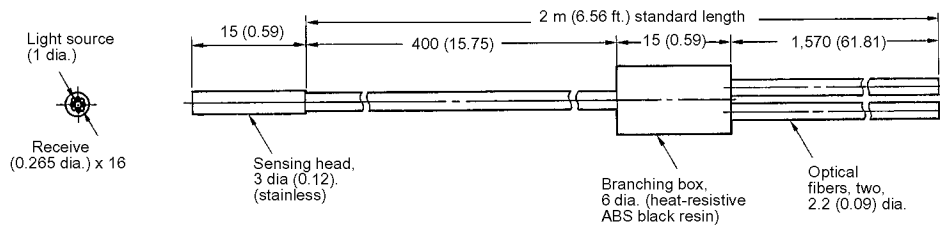

E32-DC50, E32-DC200,
E32-DC500, E32-DC1000

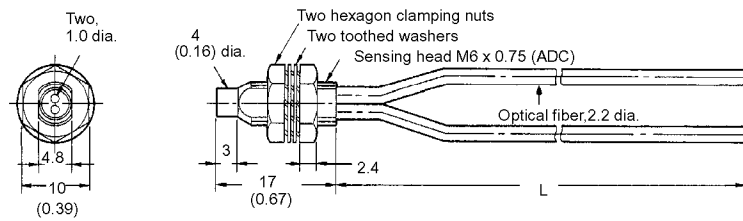

| Part number | L |
|-------------|-----------------|
| E32-DC50 | 50 cm (19 in) |
| E32-DC200 | 2 m (6.56 ft.) |
| E32-DC500 | 5 m (16.3 ft.) |
| E32-DC1000 | 10 m (32.8 ft.) |

E32-DC200C

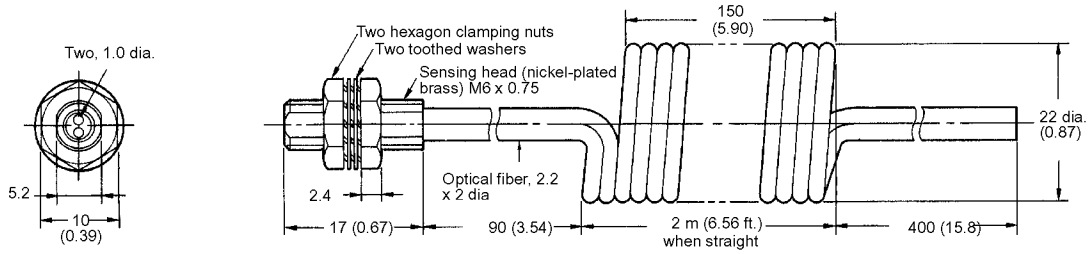

E32-DC200E

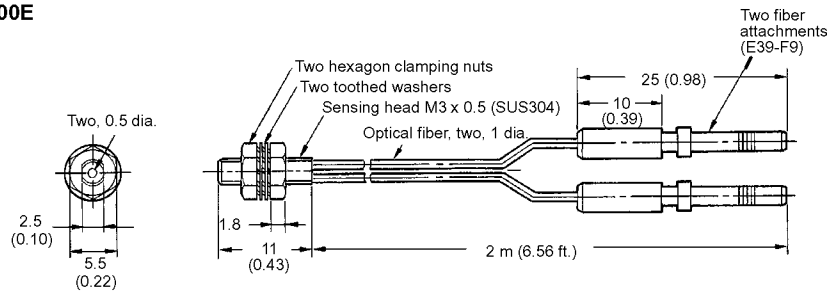

Armored Type

**E32-UDAT1-3F
E32-UDAT1-6F**

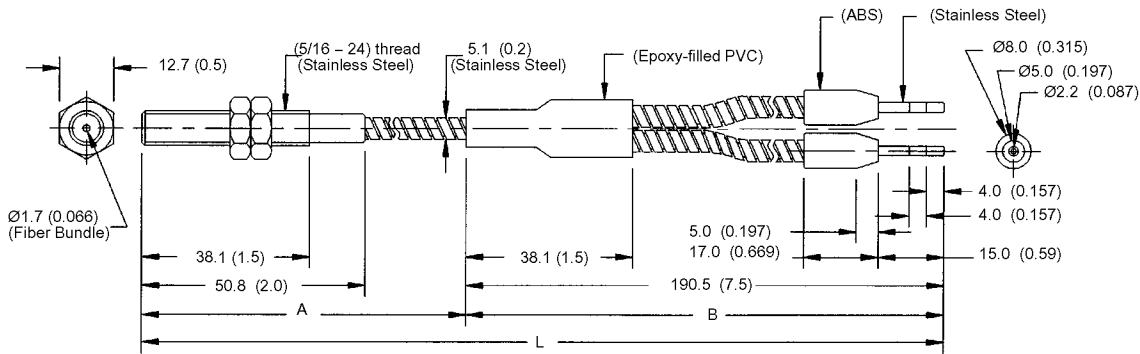

Note: Distance A can withstand 150°C (302°F); Distance B can withstand 70°C (158°F); L=3ft. or 6ft.

**E32-UDBT1-3F
E32-UDBT1-6F**

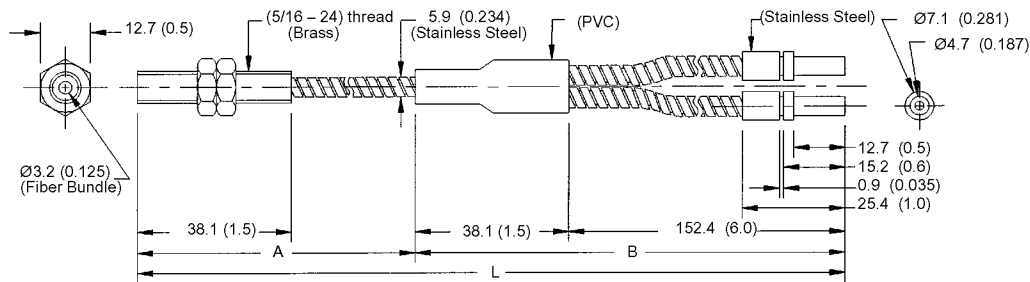

Note: Distance A can withstand 200°C (392°F); Distance B can withstand 70°C (158°F); L=3ft. or 6ft.

Probe Type

E32-DC33

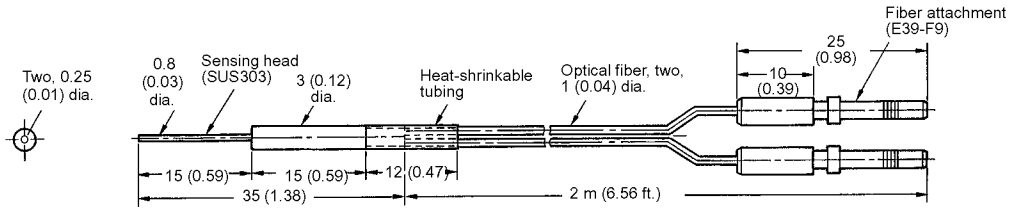

E32-DC200B
E32-DC200B4

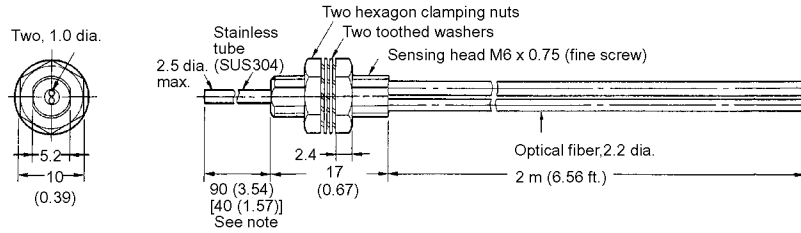

Note: The values in the brackets are for the E32-DC200B4.

E32-DC200D
E32-DC200D4

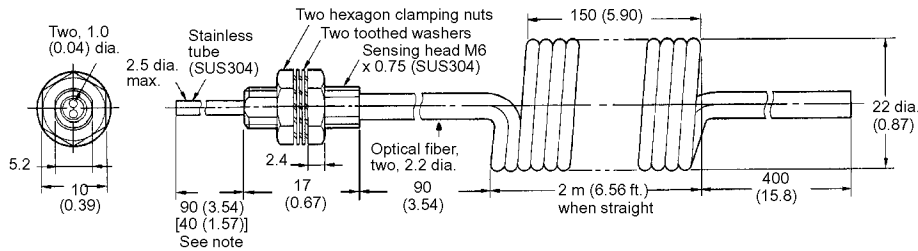

Note: The value in the brackets is for the E32-DC200D4.

E32-DC200F
E32-DC200F4

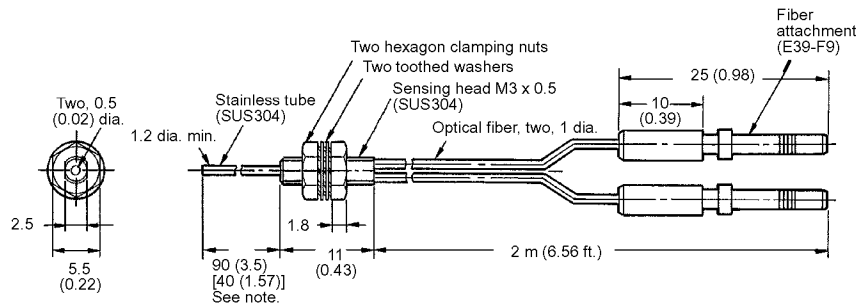

Note: The values in the brackets are for the E32-TC200F4.

E32-DC9G
E32-DC9G4

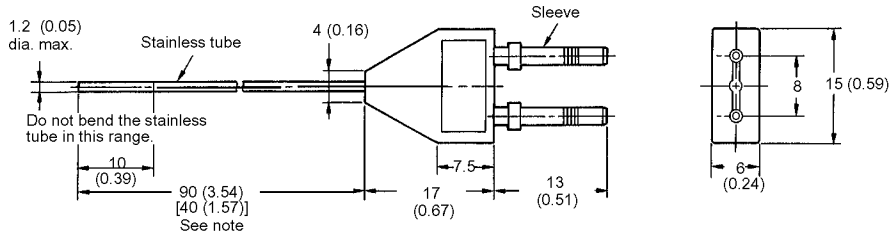

Note: The values in the brackets are for the E32-DC9G4.

Side Beam Type

E32-D14L

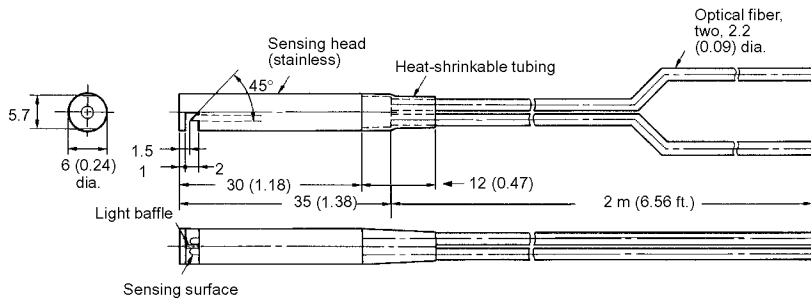

E32-D24

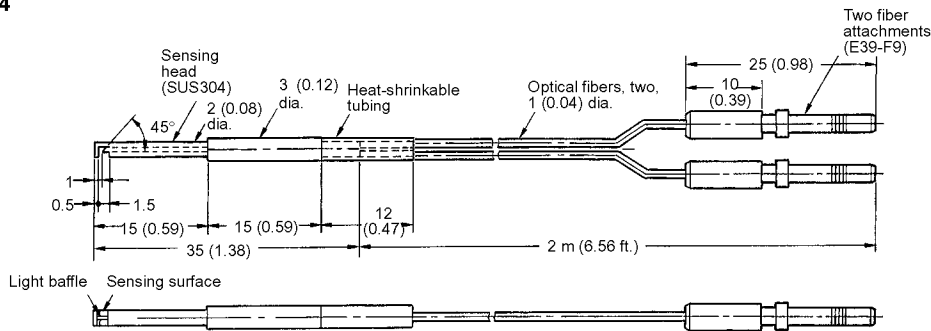

High Temperature Type

E32-D51

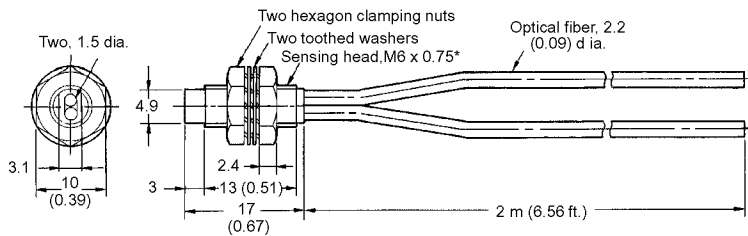

*nickel-plated brass

Note: Resistant temperature is 150°C (302°F). Resistant temperature is 130°C (266°F) when used continuously.

E32-D61

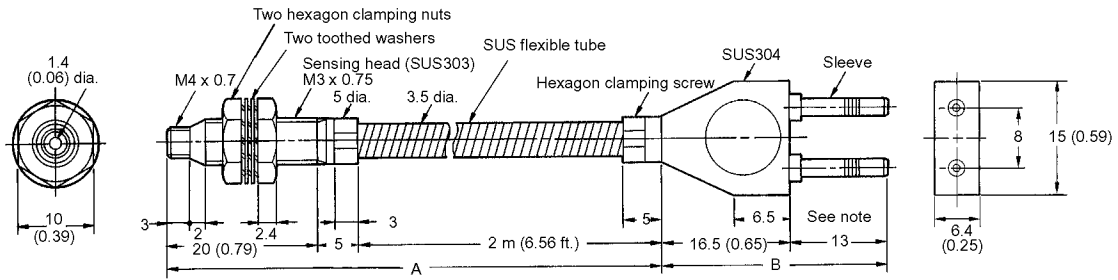

Note: Section A resists 300°C (572°F) and section B (which is inserted to the amplifier) resists 110°C (230°F). The operating temperature of section B must also be within the withstand temperature range of the amplifier.

E32-D73

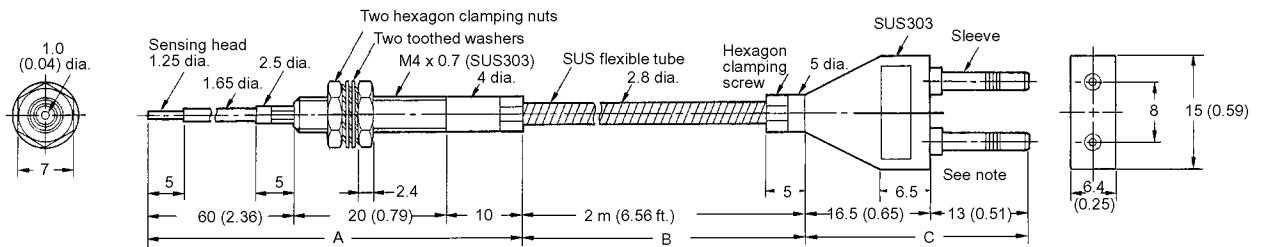

Note: Section A resists 400°C (752°F), section B resists 300°C (572°F) and section C (which is inserted to the amplifier) resists 110°C (230°F). The operating temperature of section C must also be within the withstand temperature range of the amplifier.

Convergent Type and Special Purpose

E32-D12F

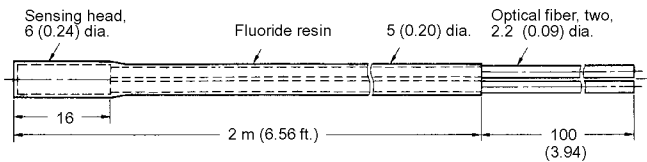

E32-L24L

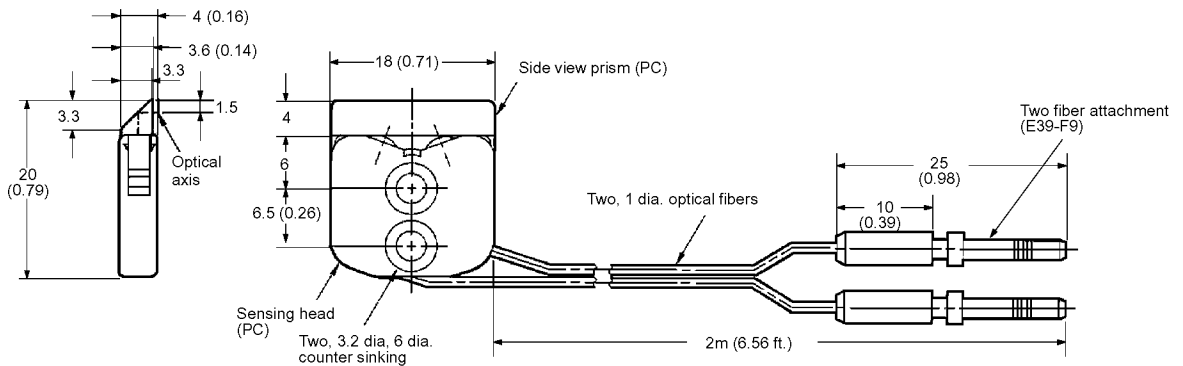

E32-L25

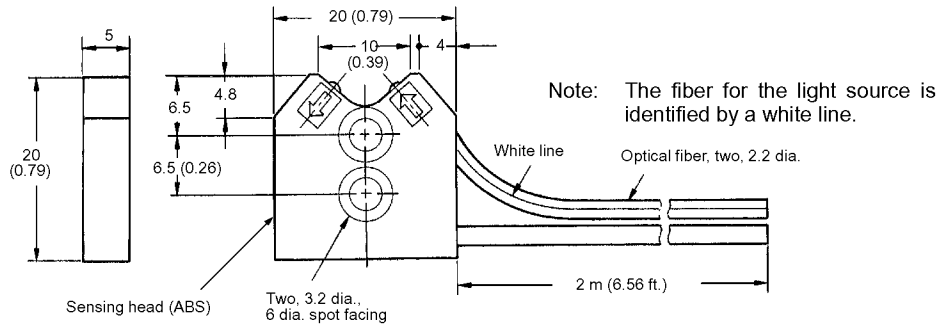

E32-L25A

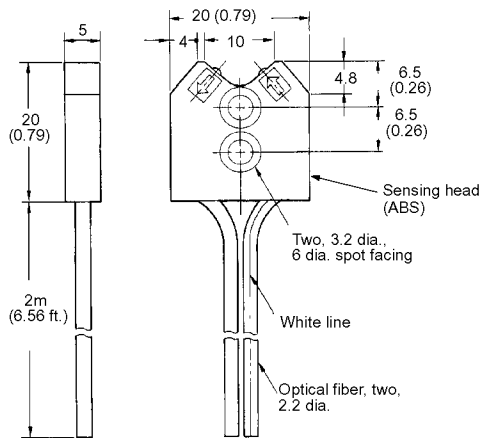

E32-L25L

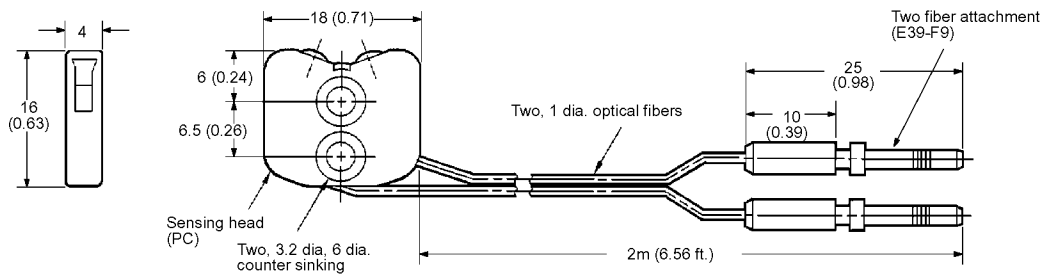

■ RETROREFLECTIVE TYPE

Special Purpose

E32-R16

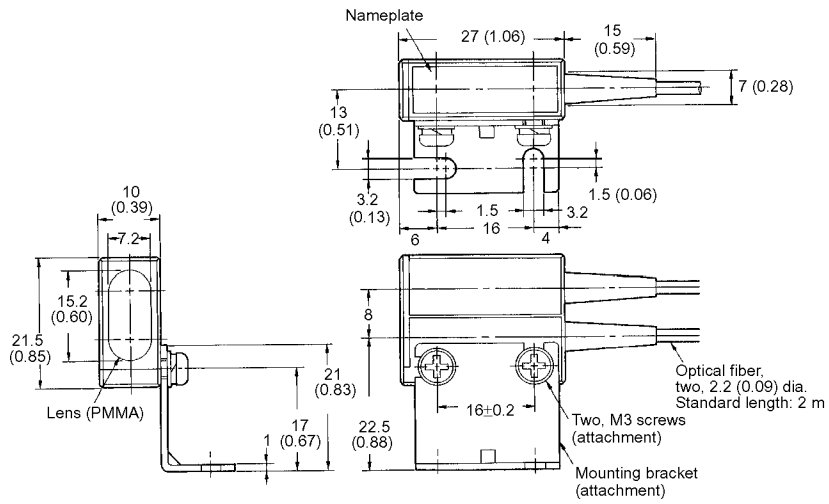

E32-R21

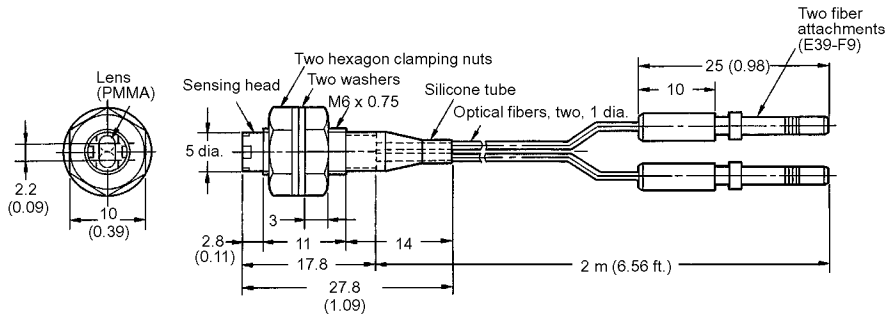

Installation

■ CUTTING FIBER

Insert a fiber into the Fiber Cutter and determine the length of the fiber to be cut.

Press down the Fiber Cutter in a single stroke to cut the fiber.

When the fiber is cut, an insertion mark is inscribed on the fiber.

For a 2.2-mm dia. standard fiber only.

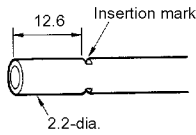

Insert a fiber into the Fiber Cutter in the direction indicated by the arrow (refer to the following figure).

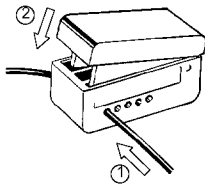

The cutting holes cannot be used twice. If the same hole is used twice, the cutting face of the fiber will be rough and the sensing distance will be reduced. Always use an unused hole.

Use either one of the two holes on the right (refer to the following figure) to cut a thin fiber as follows:

1. An attachment is temporarily fitted to a thin fiber before shipment.

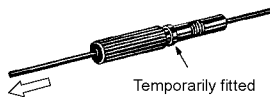

2. Secure the attachment after adjusting the position of it in the direction indicated by the arrow.
3. Insert the fiber into the E39-F4 to cut.

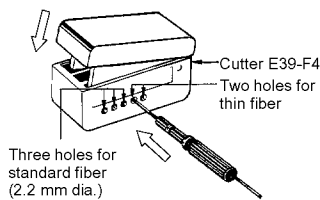

Note: Insert the fiber in the direction indicated by the arrow.

■ BENDING RADIUS

E39-F11 Sleeve Bender

The bending radius of the stainless tube should be as large as possible. The smaller the bending radius becomes, the shorter the sensing distance will be.

Insert the tip of the stainless sleeve to the Sleeve Bender and bend the stainless sleeve slowly along the curve of the Sleeve Bender (refer to the figure).

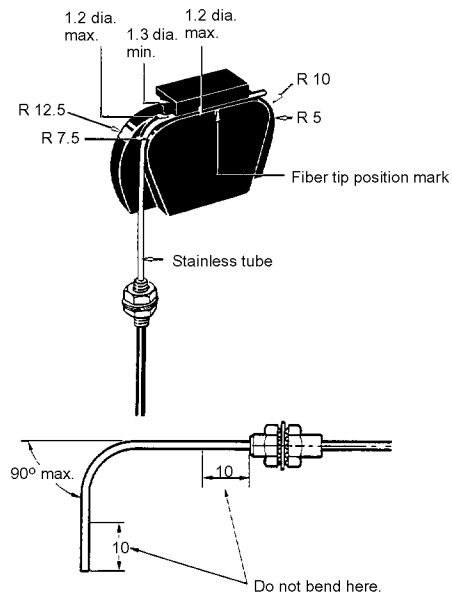

■ FIBER UNITS WITH 90° BEND IN STAINLESS STEEL TUBE

Applicable Models

E32-TC200B/TC200F/DC200F

Appearance

Stainless Steel Tube with a 90° Bend at the Tip

Length
 ℓ_1 R

| Bending radius | $\ell_1 (+1)$ | |
|----------------|---------------|---------|
| R 5.0 | 10.0 mm | 15.0 mm |
| R 7.5 | 12.5 mm | 17.5 mm |
| R 10.0 | 15.0 mm | 20.0 mm |
| R 12.5 | 17.5 mm | 22.5 mm |

The length overall is 120 mm max.

Note: If larger ℓ_1 is required, use the E39-F11 Sleeve Bender.

Stainless Steel Tube with a 90° Bend at the Base

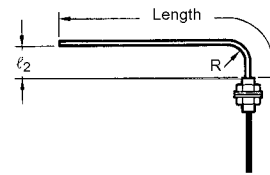

| Bending radius | $\ell_1 (+1)$ | |
|----------------|---------------|---------|
| R 5.0 | 5.0 mm | 10.0 mm |
| R 7.5 | 7.5 mm | 17.5 mm |
| R 10.0 | 10.0 mm | 20.0 mm |
| R 12.5 | 12.5 mm | 22.5 mm |

The length overall is 120 mm max.

Note: If larger ℓ_2 is required, use the E39-F11 Sleeve Bender.

Sensing Distance for Tubes with 90° Bends

| Part Number | Amplifier | Bending Radius | | | | |
|-------------|-----------|----------------|--------|--------|--------|--------|
| | | Standard | R5.0 | R7.5 | R10.0 | R12.5 |
| E32-TC200B | E3X-H11 | 400 mm | 260 mm | 330 mm | 360 mm | 400 mm |
| | E3X-A□□ | 180 mm | 110 mm | 140 mm | 160 mm | 180 mm |
| E32-TC200F | E3X-H11 | 100 mm | 55 mm | 100 mm | 100 mm | 100 mm |
| | E3X-A□□ | 50 mm | 30 mm | 50 mm | 50 mm | 50 mm |
| E32-DC200F | E3X-H11 | 36 mm | 30 mm | 36 mm | 36 mm | 36 mm |
| | E3X-A□□ | 18 mm | 10 mm | 18 mm | 18 mm | 18 mm |

■ FIBER UNIT WITH LONGER FIBER

Applicable Models

E32-TC200/-DC200
E32-TC200B/-DC200B
E32-TC200E/-DC200E
E32-TC200F/-DC200F
E32-TC200A

Appearance

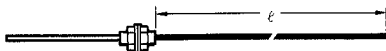

The length can be ordered in increments of 1 m between 6 m min. and 20 m max.. (2-m and 5-m fiber length types are standard for E32-TC200, E32-DC200.)

■ HANDLING

E32-D51/-T51 Heat-resisting Fiber

The bending radius of the fibers should be 35 mm min.

Connecting fibers via the E39-F10 Fiber Connector is not possible.

The withstand temperature of the Heat-Resisting Fibers is 150°C max. In continuous operation, the ambient temperature should be 130°C max.

E32-T14/-T51

If the sensor is ON because some object in front of the lenses reflects light, attach the black seals (sold together) to the lenses.

E32-T14/-G14

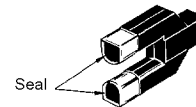

E32-L25 (A) Wafer Sensor

Insert the fiber with a white line into the light projection side of the Amplifier.

The tightening force of the sensor head is 8 kgf • cm (0.75 N • m).

Avoid places where water could be sprayed onto the E32-L25(A).

E32-T16 Slit Seal (Attachment)

Peel the E32-T16 Slit Seal off the ground paper and affix the Slit Seal to the sensing face of the sensor so that the corners of the Slit Seal fit in with the corners of the sensing face. To sense an object at a distance of 30 cm max., a 0.5-mm wide Slit Seal must be used.

E32-T16 Sensing Head

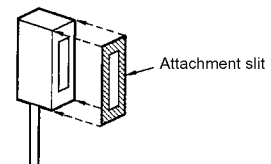

■ ATTACHMENT UNITS

Applications

E39-F10 Fiber Connector

Use the following procedure (refer to the figure) to connect fibers via the Fiber Connector.

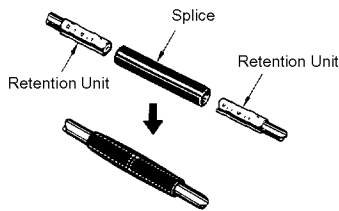

Each fiber should be as close as possible before they are connected.

Sensing distance will be reduced by approximately 25% when fibers are connected.

Only fibers with 2.2 mm dia. can be connected.

Protective Spiral Tube

Insert a fiber to the Protective Spiral Tube from the head connector side (screwed) of the tube.

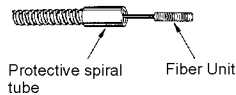

Push the fiber into the Protective Spiral Tube. The tube should be straight so that the fiber is not twisted when inserted. Then turn the end cap of the spiral tube.

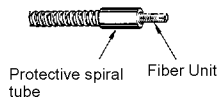

Secure the Protective Spiral Tube on a suitable place with the attached nut.

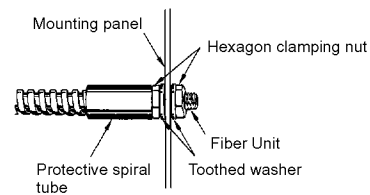

Use the attached saddle to secure the end cap of the Protective Spiral Tube. To secure the Protective Spiral Tube at a position other than the end cap, apply tape to the tube so that the portion becomes thicker in diameter.

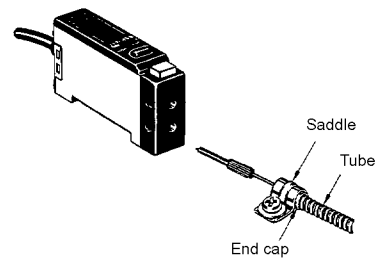

E39-F3A Reflective Unit Lens

When the E39-F3A is attached to the fiber, the E3X can sense the light reflected from the interior of the E39-F3A. If this happens, adjust the sensitivity of the E3X Amplifier with Sensitivity Adjustor.

Place a sensing object or white paper at the sensing distance set and adjust the insertion length of the Fiber Unit to the E39-F3A so that the light spot is as small as possible. Then fix the position of the Fiber Unit with the hexagonal wrench (attachment)

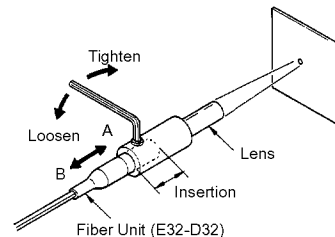

A: The focus is farther than the E39-F3A.
B: The focus is closer than the E39-F3A

NOTE: DIMENSIONS SHOWN ARE IN MILLIMETERS. To convert millimeters to inches divide by 25.4.

OMRON®

OMRON ELECTRONICS, INC.

One East Commerce Drive
Schaumburg, IL 60173

1-800-55-OMRON

OMRON CANADA, INC.

885 Milner Avenue
Scarborough, Ontario M1B 5V8

416-286-6465

Threaded Cylindrical Photoelectric Sensors with Built-in Amplifier for Use as an Optical Proximity Sensor

- M18 DIN-sized cylindrical housing
- Housing materials: plastic, nickel-brass, and stainless steel
- Improved degree of protection
- Retroreflective polarized type (2-m MSR: Mirror Surface Rejection): Metal housing type only
- Sensing distance, separate type: 7 m
- Long sensing distance (30 cm) with sensitivity adjustor for diffuse type (DC switching type)
- DC switching type with connectors for easy maintenance
- Full metal plug-in type
- Wide operating voltage range (10 to 30 VDC or 24 to 240 VAC)
- Short-circuit and reverse connection protection (DC switching type)
- UL and CSA approved (AC switching type).
- CE marking



Ordering Information

■ DC-switching Models with Plastic Housing

| Operating modes | Connection method | Control output | Sensing method | Sensing distance | Degree of protection | Remarks | Model |
|--------------------------------------|-------------------|----------------|--------------------|------------------|----------------------|----------------------|------------------------------|
| --- | Pre-wired | N. A. | Through-beam | 7 m | IEC60529 IP66 | Emitter only | E3F2-7L |
| Light-ON/ Dark-ON (selectable) | Pre-wired | NPN | Through-beam | 7 m | IEC60529 IP66 | Receiver only | E3F2-7DC4 |
| | Pre-wired | PNP | Through-beam | 7 m | IEC60529 IP66 | Receiver only | E3F2-7DB4 |
| | Pre-wired | NPN | Through-beam | 7 m | IEC60529 IP66 | Receiver and Emitter | E3F2-7C4 |
| Light-ON/ Dark-ON (selectable) | Pre-wired | PNP | Through-beam | 7 m | IEC60529 IP66 | Receiver and Emitter | E3F2-7B4 |
| Light-ON/ Dark-ON (selectable) | Pre-wired | NPN | Retroreflective | 2 m | IEC60529 IP66 | Non-polarized | E3F2-R2C4 |
| Light-ON/ Dark-ON (selectable) | Pre-wired | PNP | Retroreflective | 2 m | IEC60529 IP66 | Non-polarized | E3F2-R2B4 |
| | Pre-wired | NPN | Retroreflective | 2 m | IEC60529 IP66 | Non-polarized | E3F2-R2C4-E ^{*1} |
| | Pre-wired | PNP | Retroreflective | 2 m | IEC60529 IP66 | Non-polarized | E3F2-R2B4-E ^{*1} |
| Light-ON/ Dark-ON (selectable) | Pre-wired | NPN | Diffuse reflective | 0.1 m | IEC60529 IP66 | Wide beam | E3F2-DS10C4-N ^{*2} |
| Light-ON/ Dark-ON (selectable) | Pre-wired | PNP | Diffuse reflective | 0.1 m | IEC60529 IP66 | Wide beam | E3F2-DS10B4-N ^{*2} |
| Light-ON/ Dark-ON (selectable) | Pre-wired | NPN | Diffuse reflective | 0.3 m | IEC60529 IP66 | Sensitivity adjustor | E3F2-DS30C4 |
| Light-ON/ Dark-ON (selectable) | Pre-wired | PNP | Diffuse reflective | 0.3 m | IEC60529 IP66 | Sensitivity adjustor | E3F2-DS30B4 |
| --- | Connector | N. A. | Through-beam | 7 m | IEC60529 IP66 | Emitter only | E3F2-7L-P1 |
| Light-ON/ Dark-ON (selectable) | Connector | NPN | Through-beam | 7 m | IEC60529 IP66 | Receiver only | E3F2-7DC4-P1 |
| | Connector | PNP | Through-beam | 7 m | IEC60529 IP66 | Receiver only | E3F2-7DB4-P1 |
| | Connector | NPN | Through-beam | 7 m | IEC60529 IP66 | Receiver and Emitter | E3F2-7C4-P1 |
| Light-ON/ Dark-ON (selectable) | Connector | PNP | Through-beam | 7 m | IEC60529 IP66 | Receiver and Emitter | E3F2-7B4-P1 |
| Light-ON/ Dark-ON (selectable) | Connector | NPN | Retroreflective | 2 m | IEC60529 IP66 | Non-polarized | E3F2-R2C4-P1 |
| Light-ON/ Dark-ON (selectable) | Connector | PNP | Retroreflective | 2 m | IEC60529 IP66 | Non-polarized | E3F2-R2B4-P1 |
| | Connector | NPN | Retroreflective | 2 m | IEC60529 IP66 | Non-polarized | E3F2-R2C4-P1-E ^{*1} |
| | Connector | PNP | Retroreflective | 2 m | IEC60529 IP66 | Non-polarized | E3F2-R2B4-P1-E ^{*1} |
| Light-ON/ Dark-ON (selectable) | Connector | NPN | Diffuse reflective | 0.1 m | IEC60529 IP66 | Wide beam | E3F2-DS10C4-P1 ^{*2} |
| Light-ON/ Dark-ON (selectable) | Connector | PNP | Diffuse reflective | 0.1 m | IEC60529 IP66 | Wide beam | E3F2-DS10B4-P1 ^{*2} |
| Light-ON/ Dark-ON (selectable) | Connector | NPN | Diffuse reflective | 0.3 m | IEC60529 IP66 | Sensitivity adjustor | E3F2-DS30C4-P1 |
| Light-ON/ Dark-ON (selectable) | Connector | PNP | Diffuse reflective | 0.3 m | IEC60529 IP66 | Sensitivity adjustor | E3F2-DS30B4-P1 |

Note: NPN: Transistor output, NPN open collector

PNP: Transistor output, PNP open collector

^{*1} Model numbers ending with the suffix "-E" are models without the E39-R1 Retroreflector.

^{*2} All diffuse-reflective DS10 models have wide-beam characteristics.

■ DC-switching Models with Metal Housing

Nickel-brass Housing Models

| Operating mode | Connection method | Control output | Sensing method | Sensing distance | Degree of protection | Remarks | Model |
|--------------------------------------|-------------------|----------------|--------------------|------------------|----------------------|----------------------|---------------------------------|
| --- | Pre-wired | N. A. | Through-beam | 7 m | IEC60529 IP66 | Emitter only | E3F2-7L-M |
| Light-ON/ Dark-ON (selectable) | Pre-wired | NPN | Through-beam | 7 m | IEC60529 IP66 | Receiver only | E3F2-7DC4-M |
| | Pre-wired | PNP | Through-beam | 7 m | IEC60529 IP66 | Receiver only | E3F2-7DB4-M |
| | Pre-wired | NPN | Through-beam | 7 m | IEC60529 IP66 | Receiver and Emitter | E3F2-7C4-M ^{*2} |
| | Pre-wired | PNP | Through-beam | 7 m | IEC60529 IP66 | Receiver and Emitter | E3F2-7B4-M ^{*2} |
| Light-ON/ Dark-ON (selectable) | Pre-wired | NPN | Retroreflective | 2 m | IEC60529 IP66 | Polarized | E3F2-R2RC4-M ^{*2} |
| Light-ON/ Dark-ON (selectable) | Pre-wired | PNP | Retroreflective | 2 m | IEC60529 IP66 | Polarized | E3F2-R2RB4-M ^{*2} |
| | Pre-wired | NPN | Retroreflective | 2 m | IEC60529 IP66 | Polarized | E3F2-R2RC4-M-E ^{*1} |
| | Pre-wired | PNP | Retroreflective | 2 m | IEC60529 IP66 | Polarized | E3F2-R2RB4-M-E ^{*1} |
| Light-ON/ Dark-ON (selectable) | Pre-wired | NPN | Diffuse reflective | 0.1 m | IEC60529 IP66 | Wide beam | E3F2-DS10C4-M ^{*2} |
| Light-ON/ Dark-ON (selectable) | Pre-wired | PNP | Diffuse reflective | 0.1 m | IEC60529 IP66 | Wide beam | E3F2-DS10B4-M ^{*2} |
| Light-ON/ Dark-ON (selectable) | Pre-wired | NPN | Diffuse reflective | 0.3 m | IEC60529 IP66 | Sensitivity adjustor | E3F2-DS30C4-M ^{*2} |
| Light-ON/ Dark-ON (selectable) | Pre-wired | PNP | Diffuse reflective | 0.3 m | IEC60529 IP66 | Sensitivity adjustor | E3F2-DS30B4-M ^{*2} |
| --- | Connector | N. A. | Through-beam | 7 m | IEC60529 IP66 | Emitter only | E3F2-7L-M1-M |
| Light-ON/ Dark-ON (selectable) | Connector | NPN | Through-beam | 7 m | IEC60529 IP66 | Receiver only | E3F2-7DC4-M1-M |
| | Connector | PNP | Through-beam | 7 m | IEC60529 IP66 | Receiver only | E3F2-7DB4-M1-M |
| | Connector | NPN | Through-beam | 7 m | IEC60529 IP66 | Receiver and Emitter | E3F2-7C4-M1-M ^{*2} |
| Light-ON/ Dark-ON (selectable) | Connector | PNP | Through-beam | 7 m | IEC60529 IP66 | Receiver and Emitter | E3F2-7B4-M1-M ^{*2} |
| Light-ON/ Dark-ON (selectable) | Connector | NPN | Retroreflective | 2 m | IEC60529 IP66 | Polarized | E3F2-R2RC4-M1-M ^{*2} |
| Light-ON/ Dark-ON (selectable) | Connector | PNP | Retroreflective | 2 m | IEC60529 IP66 | Polarized | E3F2-R2RB4-M1-M ^{*2} |
| | Connector | NPN | Retroreflective | 2 m | IEC60529 IP66 | Polarized | E3F2-R2RC4-M1-M-E ^{*1} |
| | Connector | PNP | Retroreflective | 2 m | IEC60529 IP66 | Polarized | E3F2-R2RB4-M1-M-E ^{*1} |
| Light-ON/ Dark-ON (selectable) | Connector | NPN | Diffuse reflective | 0.1 m | IEC60529 IP66 | Wide beam | E3F2-DS10C4-M1-M ^{*2} |
| Light-ON/ Dark-ON (selectable) | Connector | PNP | Diffuse reflective | 0.1 m | IEC60529 IP66 | Wide beam | E3F2-DS10B4-M1-M ^{*2} |
| Light-ON/ Dark-ON (selectable) | Connector | NPN | Diffuse reflective | 0.3 m | IEC60529 IP66 | Sensitivity adjustor | E3F2-DS30C4-M1-M ^{*2} |
| Light-ON/ Dark-ON (selectable) | Connector | PNP | Diffuse reflective | 0.3 m | IEC60529 IP66 | Sensitivity adjustor | E3F2-DS30B4-M1-M ^{*2} |
| --- | Pre-wired | N. A. | Through-beam | 7 m | IEC60529 IP67 | Emitter only | E3F2-7L-C |
| Light-ON/ Dark-ON (selectable) | Pre-wired | NPN | Through-beam | 7 m | IEC60529 IP67 | Receiver only | E3F2-7DC4-C |
| | Pre-wired | PNP | Through-beam | 7 m | IEC60529 IP67 | Receiver only | E3F2-7DB4-C |
| | Pre-wired | NPN | Through-beam | 7 m | IEC60529 IP67 | Receiver and Emitter | E3F2-7C4-C ^{*2} |

| Operating mode | Connection method | Control output | Sensing method | Sensing distance | Degree of protection | Remarks | Model |
|--------------------------------------|-------------------|----------------|--------------------|------------------|----------------------|----------------------|---------------------------------|
| Light-ON/ Dark-ON (selectable) | Pre-wired | PNP | Through-beam | 7 m | IEC60529 IP67 | Receiver and Emitter | E3F2-7B4-C* ² |
| Light-ON/ Dark-ON (selectable) | Pre-wired | NPN | Retroreflective | 2 m | IEC60529 IP67 | Polarized | E3F2-R2RC4-C* ² |
| Light-ON/ Dark-ON (selectable) | Pre-wired | PNP | Retroreflective | 2 m | IEC60529 IP67 | Polarized | E3F2-R2RB4-C* ² |
| | Pre-wired | NPN | Retroreflective | 2 m | IEC60529 IP67 | Polarized | E3F2-R2RC4-C-E* ¹ |
| | Pre-wired | PNP | Retroreflective | 2 m | IEC60529 IP67 | Polarized | E3F2-R2RB4-C-E* ¹ |
| Light-ON/ Dark-ON (selectable) | Pre-wired | NPN | Diffuse reflective | 0.1 m | IEC60529 IP67 | Wide beam | E3F2-DS10C4-C* ² |
| Light-ON/ Dark-ON (selectable) | Pre-wired | PNP | Diffuse reflective | 0.1 m | IEC60529 IP67 | Wide beam | E3F2-DS10B4-C* ² |
| --- | Connector | N. A. | Through-beam | 7 m | IEC60529 IP67 | Emitter only | E3F2-7L-M1-C |
| Light-ON/ Dark-ON (selectable) | Connector | NPN | Through-beam | 7 m | IEC60529 IP67 | Receiver only | E3F2-7DC4-M1-C |
| | Connector | PNP | Through-beam | 7 m | IEC60529 IP67 | Receiver only | E3F2-7DB4-M1-C |
| | Connector | NPN | Through-beam | 7 m | IEC60529 IP67 | Receiver and Emitter | E3F2-7C4-M1-C* ² |
| | Connector | PNP | Through-beam | 7 m | IEC60529 IP67 | Receiver and Emitter | E3F2-7B4-M1-C* ² |
| Light-ON/ Dark-ON (selectable) | Connector | NPN | Retroreflective | 2 m | IEC60529 IP67 | Polarized | E3F2-R2RC4-M1-C* ² |
| Light-ON/ Dark-ON (selectable) | Connector | PNP | Retroreflective | 2 m | IEC60529 IP67 | Polarized | E3F2-R2RB4-M1-C* ² |
| | Connector | NPN | Retroreflective | 2 m | IEC60529 IP67 | Polarized | E3F2-R2RC4-M1-C-E* ¹ |
| | Connector | PNP | Retroreflective | 2 m | IEC60529 IP67 | Polarized | E3F2-R2RB4-M1-C-E* ¹ |
| Light-ON/ Dark-ON (selectable) | Connector | NPN | Diffuse reflective | 0.1 m | IEC60529 IP67 | Wide beam | E3F2-DS10C4-M1-C* ² |
| Light-ON/ Dark-ON (selectable) | Connector | PNP | Diffuse reflective | 0.1 m | IEC60529 IP67 | Wide beam | E3F2-DS10B4-M1-C* ² |

Note: All diffuse-reflective DS10 models have wide-beam characteristics.

(-E) *¹ Model numbers ending with the suffix "-E" are models without the E39-R1 Retroreflector.

(-M) *² Special models for harsh environments are available to satisfy the higher degree of protection IP67. These models are available in nickel-brass (replace "-M" with "-C") or stainless steel (replace "-M" with "-S"), except for 0.3-m diffuse-reflective models.

■ Stainless Housing Models

| Operating modes | Connection method | Control output | Sensing method | Sensing distance | Degree of protection | Remarks | Model |
|--------------------------------------|-------------------|----------------|--------------------|------------------|----------------------|----------------------|------------------------------|
| --- | Pre-wired | N. A. | Through-beam | 7 m | IEC60529 IP67 | Emitter only | E3F2-7L-S |
| Light-ON/ Dark-ON (selectable) | Pre-wired | NPN | Through-beam | 7 m | IEC60529 IP67 | Receiver only | E3F2-7DC4-S |
| | Pre-wired | PNP | Through-beam | 7 m | IEC60529 IP67 | Receiver only | E3F2-7DB4-S |
| | Pre-wired | NPN | Through-beam | 7 m | IEC60529 IP67 | Receiver and Emitter | E3F2-7C4-S |
| | Pre-wired | PNP | Through-beam | 7 m | IEC60529 IP67 | Receiver and Emitter | E3F2-7B4-S |
| Light-ON/ Dark-ON (selectable) | Pre-wired | NPN | Retroreflective | 2 m | IEC60529 IP67 | Polarized | E3F2-R2RC4-S |
| Light-ON/ Dark-ON (selectable) | Pre-wired | PNP | Retroreflective | 2 m | IEC60529 IP67 | Polarized | E3F2-R2RB4-S |
| | Pre-wired | NPN | Retroreflective | 2 m | IEC60529 IP67 | Polarized | E3F2-R2RC4-S-E* ¹ |
| | Pre-wired | PNP | Retroreflective | 2 m | IEC60529 IP67 | Polarized | E3F2-R2RB4-S-E* ¹ |
| Light-ON/ Dark-ON (selectable) | Pre-wired | NPN | Diffuse reflective | 0.1 m | IEC60529 IP67 | Wide beam | E3F2-DS10C4-S |

| Operating modes | Connection method | Control output | Sensing method | Sensing distance | Degree of protection | Remarks | Model |
|--------------------------------------|-------------------|----------------|--------------------|------------------|----------------------|----------------------|---------------------------------|
| Light-ON/ Dark-ON (selectable) | Pre-wired | PNP | Diffuse reflective | 0.1 m | IEC60529 IP67 | Wide beam | E3F2-DS10B4-S |
| Light-ON/ Dark-ON (selectable) | Pre-wired | NPN | Diffuse reflective | 0.3 m | IEC60529 IP66 | Sensitivity adjustor | E3F2-DS30C4-S |
| Light-ON/ Dark-ON (selectable) | Pre-wired | PNP | Diffuse reflective | 0.3 m | IEC60529 IP66 | Sensitivity adjustor | E3F2-DS30B4-S |
| --- | Connector | N. A. | Through-beam | 7 m | IEC60529 IP67 | Emitter only | E3F2-7L-M1-S |
| Light-ON/ Dark-ON (selectable) | Connector | NPN | Through-beam | 7 m | IEC60529 IP67 | Receiver only | E3F2-7DC4-M1-S |
| | Connector | PNP | Through-beam | 7 m | IEC60529 IP67 | Receiver only | E3F2-7DB4-M1-S |
| | Connector | NPN | Through-beam | 7 m | IEC60529 IP67 | Receiver and Emitter | E3F2-7C4-M1-S |
| Light-ON/ Dark-ON (selectable) | Connector | PNP | Through-beam | 7 m | IEC60529 IP67 | Receiver and Emitter | E3F2-7B4-M1-S |
| Light-ON/ Dark-ON (selectable) | Connector | NPN | Retroreflective | 2 m | IEC60529 IP67 | Polarized | E3F2-R2RC4-M1-S |
| Light-ON/ Dark-ON (selectable) | Connector | PNP | Retroreflective | 2 m | IEC60529 IP67 | Polarized | E3F2-R2RB4-M1-S |
| Light-ON/ Dark-ON (selectable) | Connector | NPN | Retroreflective | 2 m | IEC60529 IP67 | Polarized | E3F2-R2RC4-M1-S-E ^{*1} |
| | Connector | PNP | Retroreflective | 2 m | IEC60529 IP67 | Polarized | E3F2-R2RB4-M1-S-E ^{*1} |
| | Connector | NPN | Diffuse reflective | 0.1 m | IEC60529 IP67 | Wide beam | E3F2-DS10C4-M1-S |
| Light-ON/ Dark-ON (selectable) | Connector | PNP | Diffuse reflective | 0.1 m | IEC60529 IP67 | Wide beam | E3F2-DS10B4-M1-S |
| Light-ON/ Dark-ON (selectable) | Connector | NPN | Diffuse reflective | 0.3 m | IEC60529 IP67 | Sensitivity adjustor | E3F2-DS30C4-M1-S |
| Light-ON/ Dark-ON (selectable) | Connector | PNP | Diffuse reflective | 0.3 m | IEC60529 IP67 | Sensitivity adjustor | E3F2-DS30B4-M1-S |

- Note:**
1. Material specification for stainless-steel housing case: 1,4305 (DIN), 303 (ANSI). Other material specifications are available upon request.
 2. All-stainless-steel models for harsh environments are available to satisfy the higher degree of protection IP67, except for 0.3-m diffuse-reflective models.
(-E) ^{*1} Model numbers ending with the suffix "-E" are models without the E39-R1 Retroreflector.

■ AC-switching Models with Plastic Housing

| Operating modes | Connection method | Control output | Sensing method | Sensing distance | Degree of protection | Remarks | Model |
|-----------------|-------------------|----------------------|--------------------|------------------|----------------------|----------------------|-----------------------------|
| --- | Pre-wired | --- | Through-beam | 3 m | IEC60529 IP66 | Emitter only | E3F2-3LZ |
| L-ON | Pre-wired | AC solid state (SCR) | Through-beam | 3 m | IEC60529 IP66 | Receiver only | E3F2-3DZ1 |
| D-ON | Pre-wired | AC solid state (SCR) | Through-beam | 3 m | IEC60529 IP66 | Receiver only | E3F2-3DZ2 |
| L-ON | Pre-wired | AC solid state (SCR) | Through-beam | 3 m | IEC60529 IP66 | Receiver and Emitter | E3F2-3Z1 |
| D-ON | Pre-wired | AC solid state (SCR) | Through-beam | 3 m | IEC60529 IP66 | Receiver and Emitter | E3F2-3Z2 |
| L-ON | Pre-wired | AC solid state (SCR) | Retroreflective | 2 m | IEC60529 IP66 | Non polarized | E3F2-R2Z1 |
| D-ON | Pre-wired | AC solid state (SCR) | Retroreflective | 2 m | IEC60529 IP66 | Non-polarized | E3F2-R2Z2 |
| L-ON | Pre-wired | AC solid state (SCR) | Retroreflective | 2 m | IEC60529 IP66 | Non-polarized | E3F2-R2Z1-E ^{*1} |
| D-ON | Pre-wired | AC solid state (SCR) | Retroreflective | 2 m | IEC60529 IP66 | Non-polarized | E3F2-R2Z2-E ^{*1} |
| L-ON | Pre-wired | AC solid state (SCR) | Diffuse reflective | 0.1 m | IEC60529 IP66 | Wide beam | E3F2-DS10Z1-N ^{*2} |
| D-ON | Pre-wired | AC solid state (SCR) | Diffuse reflective | 0.1 m | IEC60529 IP66 | Wide beam | E3F2-DS10Z2-N ^{*2} |

Note: L-ON: Light-ON (Fixed)

D-ON: Dark-ON (Fixed)

^{*1} Model numbers ending with the suffix "-E" are models without the E39-R1 Retroreflector.



^{*2} All diffuse-reflective DS10 models have wide-beam characteristics.

■ Accessories (Order Separately)

| Name | Model |
|----------------------------|------------------|
| Retroreflector | E39-R1, E39-R3 |
| Retroreflector (tape type) | E39-RSA, E39-RSB |
| Lens Cap | E39-F31 |
| Mounting Bracket | Y92E-B18 |

■ Connector

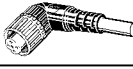
Plugs (Order Separately)

| Cable | Appearance | Cable length | Model |
|-------------------------|------------------------|---|-----------------|
| Standard | Straight (4 conductor) |  2 m | XS2F-D421-D80-A |
| | | 5 m | XS2F-D421-G80-A |
| | L-shape (4 conductor) |  2 m | XS2F-D422-D80-A |
| | | 5 m | XS2F-D422-G80-A |
| Robot (vibration-proof) | Straight (4 conductor) |  2 m | XS2F-D421-D80-R |
| | | 5 m | XS2F-D421-G80-R |
| | L-shape (4 conductor) |  2 m | XS2F-D422-D80-R |
| | | 5 m | XS2F-D422-G80-R |

Specifications

DC Switching Models

| Item | E3F2-7C4-□, E3F2-7B4-□ | E3F2-R2C4-□, E3F2-R2B4-□ | E3F2-R2RC4-□, E3F2-R2RB4-□ | E3F2-DS10C4-□, E3F2-DS10B4-□ | E3F2-DS30C4-□, E3F2-DS30B4-□ |
|---|--|-----------------------------|---|--|--|
| | Through-beam | Retroreflective | | Diffuse reflective | |
| | | Non-polarized | Polarized | | |
| Power supply voltage | 10 to 30 VDC | | | | |
| Current consumption | 45 mA max. | 25 mA max. | | | |
| Sensing distance (See note 1.) | 7 m | 2 m | 2 m (MSR) | 0.1 m | 0.3 m |
| Response time | 2.5 ms | | | | |
| Control output | Transistor (open collector) 100 mA max.; residual voltage: 2 V max. at 100 mA | | | | |
| Power reset time | 50 ms | | | | |
| Ambient illumination (See note 2.) | Incandescent lamp: 3,000 lx max. Sunlight: 10,000 lx max. | | | | |
| Ambient temperature | Operating: -25°C to 55°C (with no icing) Storage: -30°C to 70°C | | | | |
| Ambient humidity | Operating: 35% to 85% (with no condensation) Storage: 35% to 95% | | | | |
| Insulation resistance | 20 MΩ (at 500 VDC) | | | | |
| Dielectric strength | 1,000 VAC, 50/60 Hz for 1 min between current carry parts and case | | | | |
| Vibration resistance | 10 to 55 Hz, 1.5-mm double amplitude for 1 hr each in X, Y, Z directions | | | | |
| Shock resistance | 500 m/s ² (approx. 50G) | | | | |
| Degree of protection | IEC60529 IP66 for plastic and nickel-brass housing type IEC60529 IP67 for stainless-steel housing, optional for nickel-brass housing type | | | | IEC60529 IP66 |
| Light source | Infrared LED | | Red LED | Infrared LED | |
| Indicators | Light incident/power indicator for emitter (through-beam models) (red) | | | | |
| Sensitivity adjustment | Fixed | | | | Adjustable |
| Connection method | 2-m pre-wired cable or connector | | | | |
| Operation mode | Light-ON or Dark-ON selectable with wiring | | | | |
| Weight | Pre-wired cable models: Plastic case Approx. 85 g Metal case Approx. 100 g | | Connector models: Approx. 40 g Approx. 60 g | | |
| Circuit protection | Output short-circuit and power supply reverse polarity | | | | |
| Housing materials | Plastic Nickel-brass Stainless steel | Plastic | Nickel-brass Stainless steel | Plastic Nickel-brass Stainless steel | Plastic Nickel-brass Stainless steel |

- Note:**
1. Per actual stable sensing distance, for details, see the *Gain vs. Set Distance* ratios in the *Engineering Data*.
 2. The intensity of the illumination on the surface of the receiver with a 20% fluctuation of the optical output per 200 lx. This is not the maximum available operating illumination.

AC Switching Models

| Item | E3F2-3Z1, E3F2-3Z2 | E3F2-R2Z1, E3F2-R2Z2 | E3F2-DS10Z1, E3F2-DS10Z2 |
|-----------------------------------|---|-------------------------------|-------------------------------------|
| | Through-beam | Retroreflective | Diffuse reflective |
| Power supply voltage | 24 to 240 VAC \pm 10%, 50/60 Hz | | |
| Current consumption | 10 mA max. | 5 mA max. | |
| Sensing distance (see note 1) | 3 m | 0.1 to 2 m (E39-R1 Reflector) | 0.1 m (5 \times 5 cm white paper) |
| Sensing object | Opaque: 11 mm min. | Opaque: 56 mm min. | |
| Directional angle | 3° to 20° | | --- |
| Differential travel | --- | | 20% max. |
| Response time | 30 ms max. | | |
| Control output | AC solid state (SCR) 200 mA max.; residual voltage: 5 V max. at 200 mA (see note 3) | | |
| Power reset time | 100 ms | | |
| Ambient illumination (see note 2) | Incandescent lamp: 3,000 lx max. Sunlight: 10,000 lx max. | | |
| Ambient temperature | Operating: -25°C to 55°C (with no icing) Storage: -30°C to 70°C (with no icing) | | |
| Ambient humidity | Operating: 35% to 85% Storage: 35% to 95% (with no condensation) | | |
| Insulation resistance | 20 M Ω (at 500 VDC) between current carry parts and case | | |
| Dielectric strength | 1,500 VAC, 50/60 Hz for 1 min between current carry parts and case | | |
| Vibration resistance | 10 to 55 Hz, 1.5-mm double amplitude for 2 hrs each in X, Y, Z directions | | |
| Shock resistance | 500 m/s ² (approx. 50G) | | |
| Degree of protection | IEC60529 IP66, NEMA 1, 2, 4 (indoor) | | |
| Light source | Infrared | | |
| Indicators | Light incident/power indicator for light source (red) | | |
| Sensitivity adjustment | Fixed | | |
| Connection method | 2-m pre-wired cable | | |
| Operation mode | Light-ON or Dark-ON (fixed) | | |
| Circuit protection | --- | | |
| Weight | Pre-wired models: Approx. 110 g Connector models: Approx. 55 g | | |
| Housing materials | Case: ABS Lens: Acrylate resin | | |

- Note:**
1. Per actual stable sensing distance, for details, see the *Gain vs. Set Distance* ratios in the *Engineering Data*.
 2. The intensity of the illumination on the surface of the receiver with a 20% fluctuation of the optical output per 200 lx. This is not the maximum available operating illumination.
 3. When you use the Photoelectric Sensor at the temperature over 45°C, the load current must be within rated value. Please refer to the *Precautions*.

Engineering Data

Operating Range (Typical)

E3F2-7□-4□ (Through-beam)

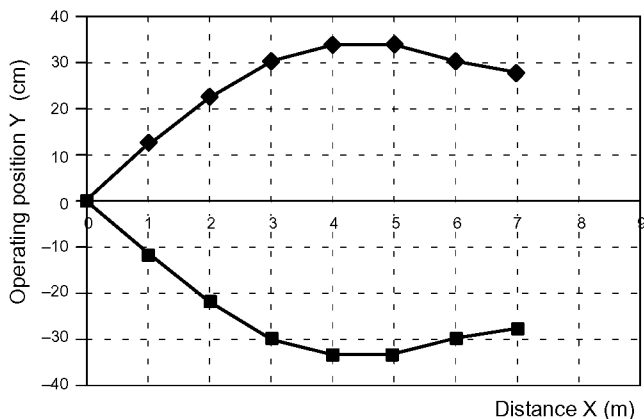

E3F2-R2R□-4□ (Retroreflective, polarized)

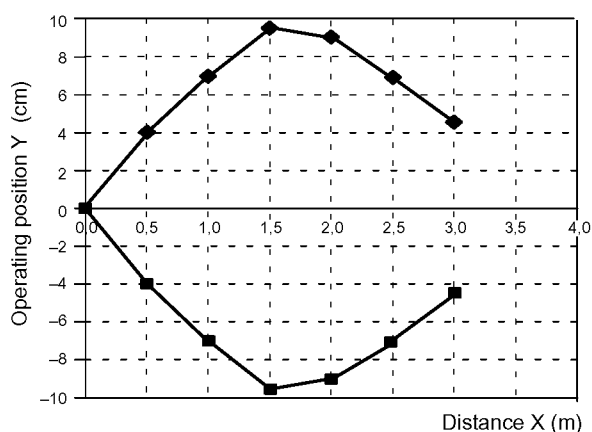

E3F2-R2□4-□□ (Retroreflective)

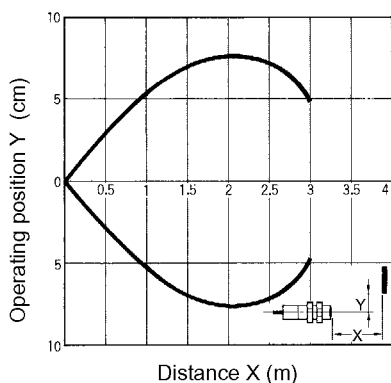

E3F2-DS10□4-N
E3F2-DS10□4-P1

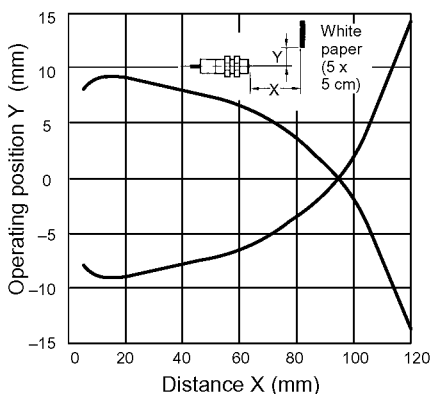

E3F2-DS30□4-□□

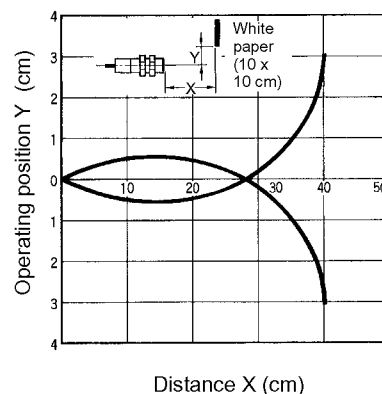

Excess Gain vs. Set Distance (Typical)

E3F2-7□4-□

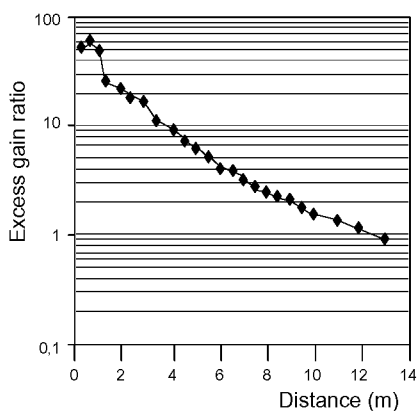

E3F2-R2R□4-□

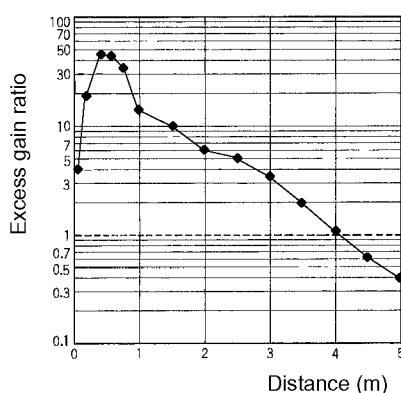

E3F2-R2□4

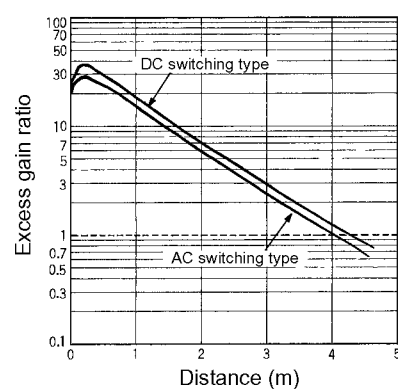

E3F2-DS10Z□-N

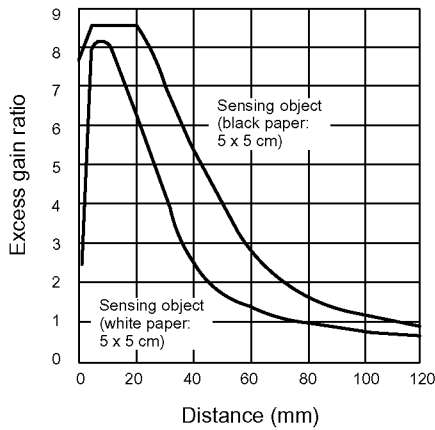

E3F2-DS10□4-N

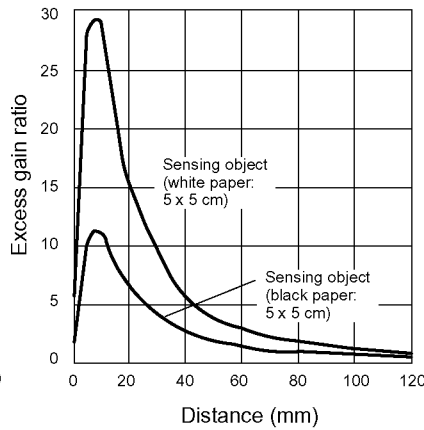

E3F2-DS30□4

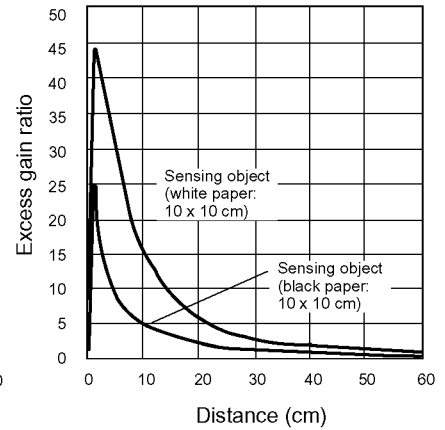

Operation

Output Circuits

| Configuration | Model | Connection method | Output transistor | Output circuit |
|---------------|--|---|---|----------------|
| NPN pre-wired | E3F2-7C4 E3F2-7C4-M E3F2-7C4-C E3F2-7C4-S E3F2-R2C4 E3F2-R2RC4-M E3F2-R2RC4-C E3F2-R2RC4-S E3F2-DS10C4-N E3F2-DS10C4-M E3F2-DS10C4-C E3F2-DS10C4-S E3F2-DS30C4 E3F2-DS30C4-M E3F2-DS30C4-S | Connect the pink and brown wires or open the pink wire. | ON when light is incident. (Light-ON) | |
| | | Connect the pink and blue wires. | ON when light is interrupted. (Dark-ON) | |
| PNP pre-wired | E3F2-7B4 E3F2-7B4-M E3F2-7B4-C E3F2-7B4-S E3F2-R2B4 E3F2-R2RB4-M E3F2-R2RB4-C E3F2-R2RB4-S E3F2-DS10B4-N E3F2-DS10B4-M E3F2-DS10B4-C E3F2-DS10B4-S E3F2-DS30B4 E3F2-DS30B4-M E3F2-DS30B4-S | Connect the pink and brown wires or open the pink wire. | ON when light is incident. (Light-ON) | |
| | | Connect the pink and blue wires. | ON when light is interrupted. (Dark-ON) | |

| Configuration | Model | Connection method | Output transistor | Output circuit |
|----------------------|---|---|---|----------------|
| NPN connector | E3F2-7C4-P1 E3F2-7C4-M1-M E3F2-7C4-M1-C E3F2-7C4-M1-S E3F2-R2C4-P1 E3F2-R2RC4-M1-M E3F2-R2RC4-M1-C E3F2-R2RC4-M1-S E3F2-DS10C4-P1 E3F2-DS10C4-M1-M E3F2-DS10C4-M1-C E3F2-DS10C4-M1-S E3F2-DS30C4-P1 E3F2-DS30C4-M1-M E3F2-DS30C4-M1-S | Connect the pink and brown wires or open the pink wire. | ON when light is incident. (Light-ON) | |
| | | Connect the pink and brown wires. | ON when light is interrupted. (Dark-ON) | |
| PNP connector | E3F2-7B4-P1 E3F2-7B4-M1-M E3F2-7B4-M1-C E3F2-7B4-M1-S E3F2-R2B4-P1 E3F2-R2RB4-M1-M E3F2-R2RB4-M1-C E3F2-R2RB4-M1-S E3F2-DS10B4-P1 E3F2-DS10B4-M1-M E3F2-DS10B4-M1-C E3F2-DS10B4-M1-S E3F2-DS30B4-P1 E3F2-DS30B4-M1-M E3F2-DS30B4-M1-S | Connect the pink and brown wires or open the pink wire. | ON when light is incident. (Light-ON) | |
| | | Connect the pink and blue wires. | ON when light is interrupted. (Dark-ON) | |
| AC switching | E3F2-3Z1 E3F2-R2Z1 E3F2-DS10Z1-N | --- (Fixed) | ON when light is incident. (Light-ON) | |
| | E3F2-3Z2 E3F2-R2Z2 E3F2-DS10Z2-N | | ON when light is interrupted. (Dark-ON) | |

Note: Terminals No. for Connector type.

Timing Chart

Light-ON Mode

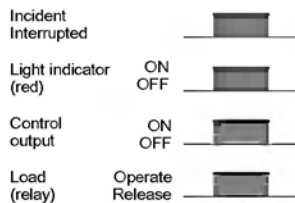

Dark-ON Mode

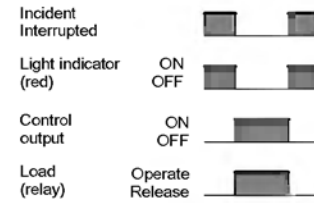

Terminals/Connections

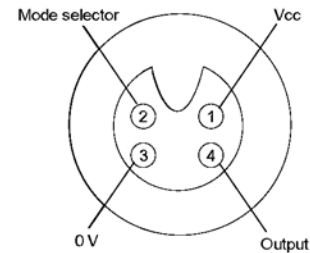

Dimensions

Note: All units are in millimeters unless otherwise indicated.

DC Switching Models

E3F2-7L

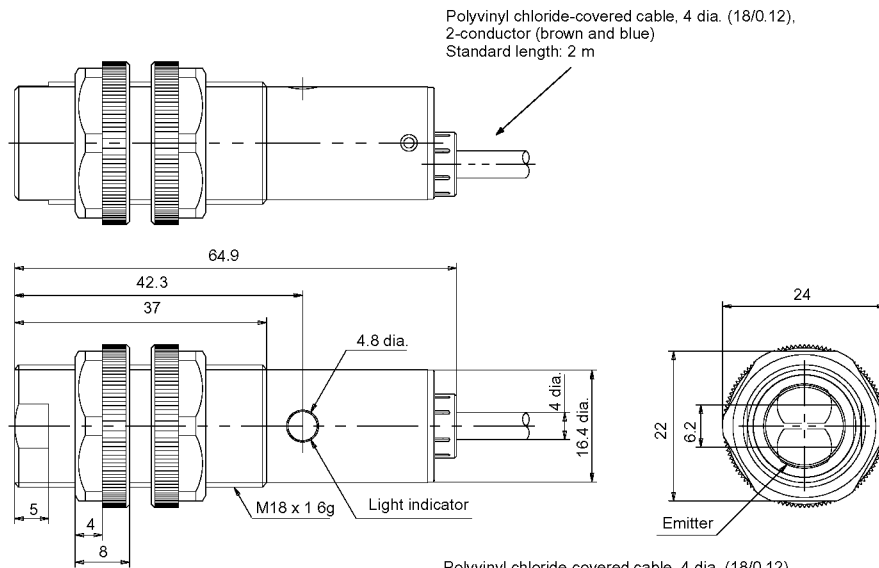

E3F2-7D□4

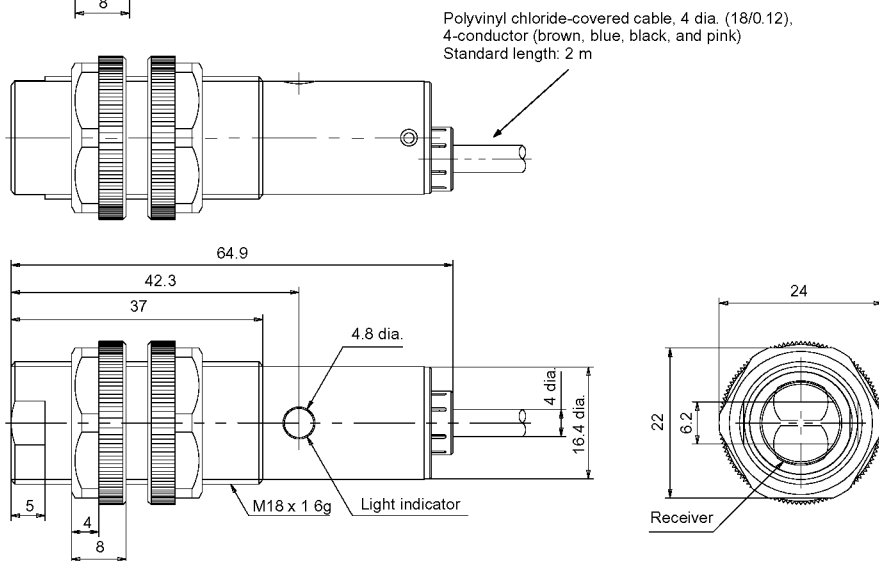

E3F2-R2□4

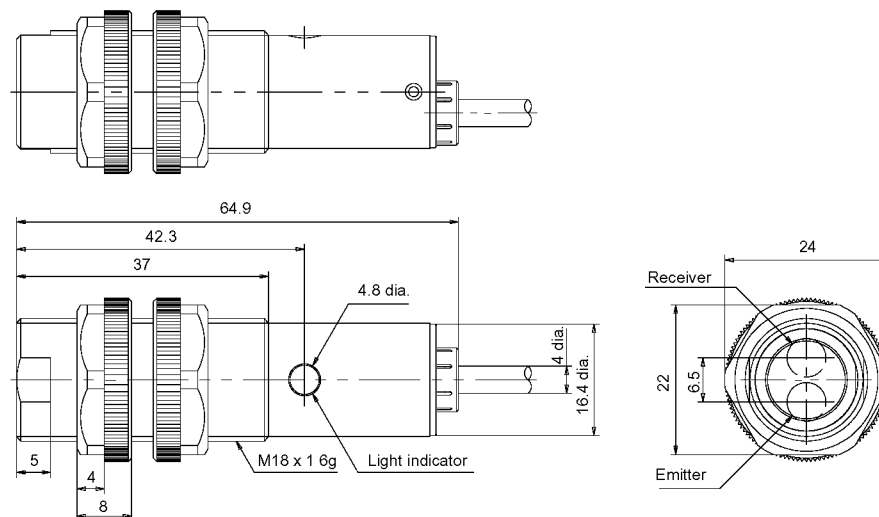

E3F2-DS10□4-N

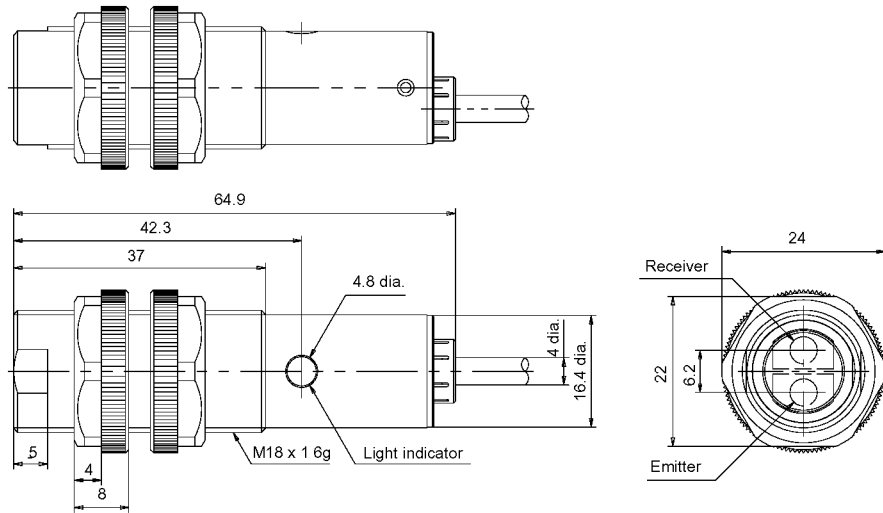

E3F2-DS30□4

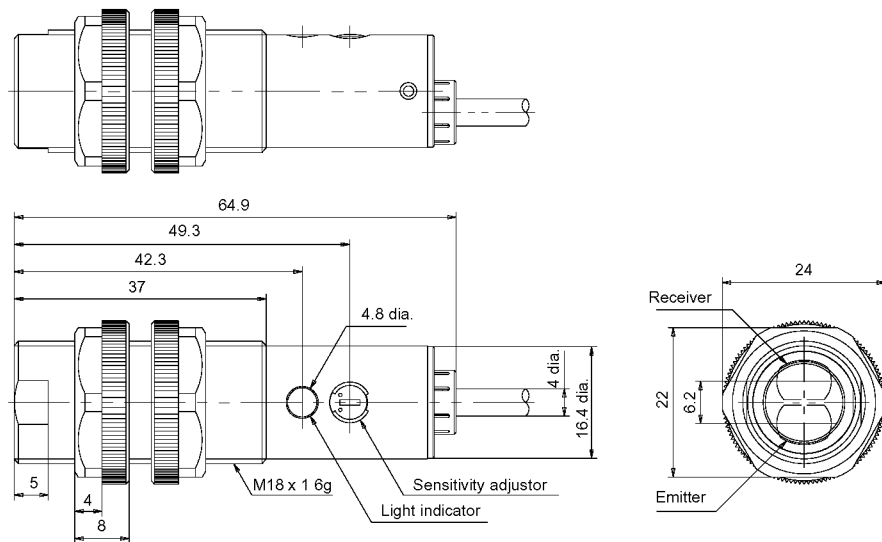

E3F2-7L-P1

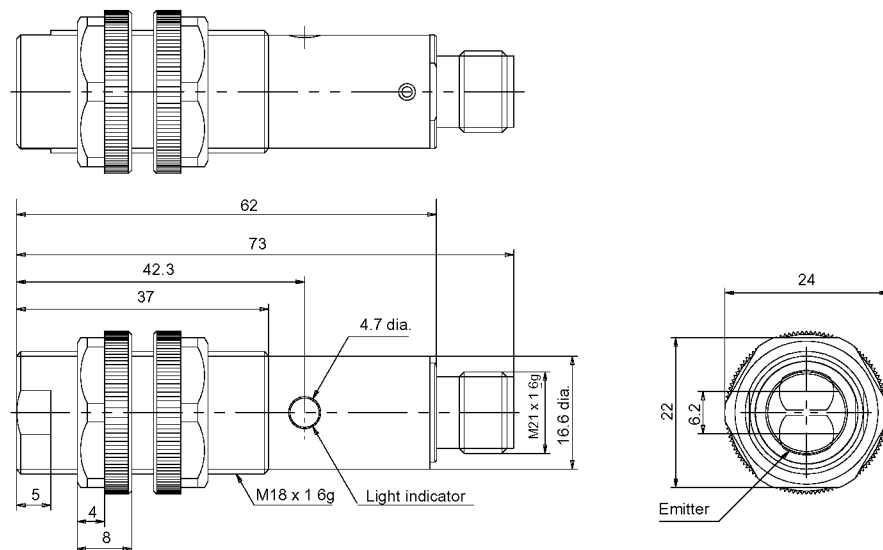

E3F2-7D□4-P1

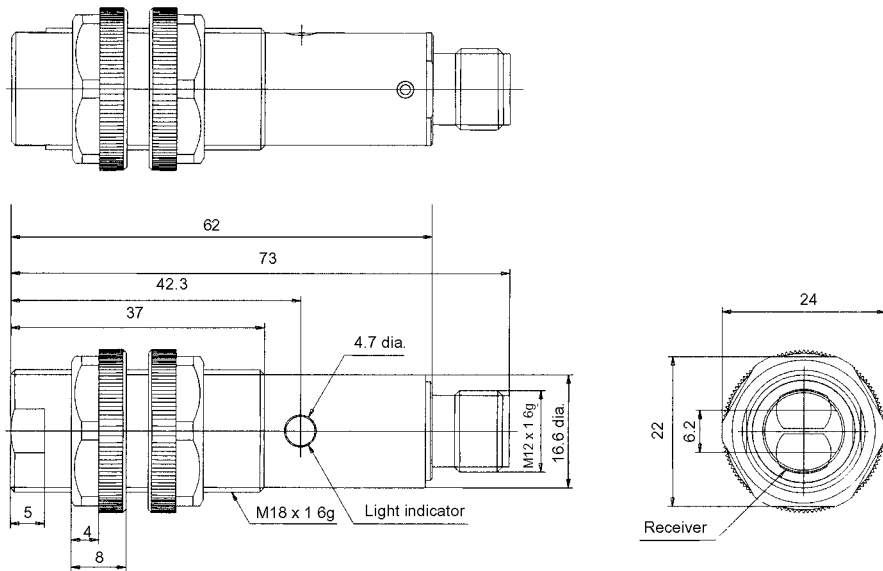

E3F2-R2□4-P1

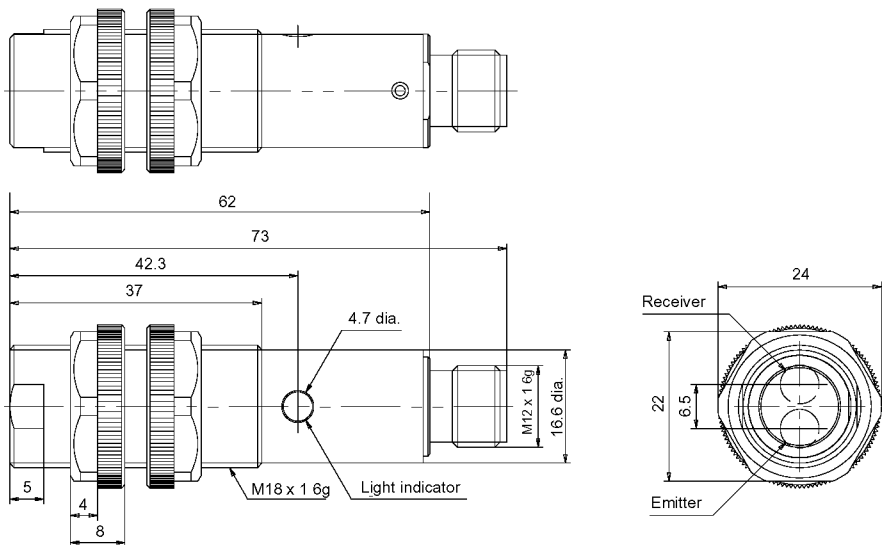

E3F2-DS10□4-P1

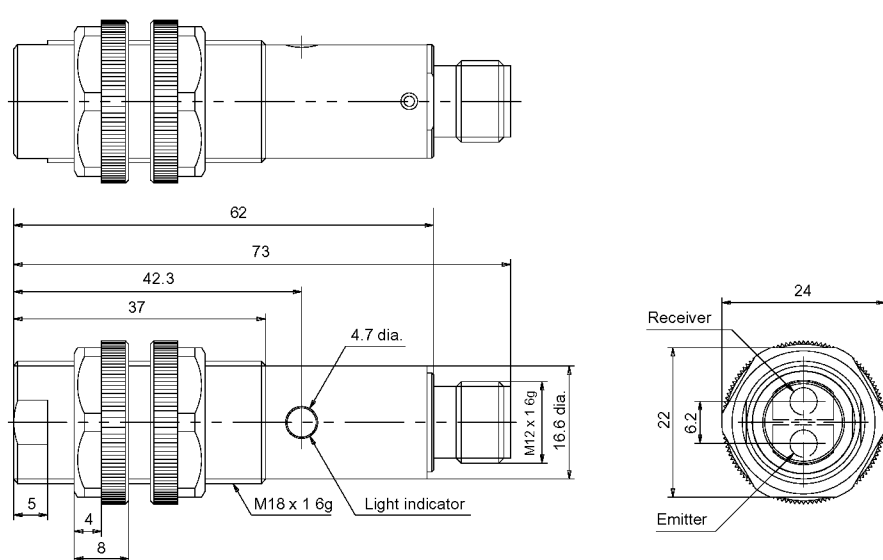

E3F2-DS30□4-P1

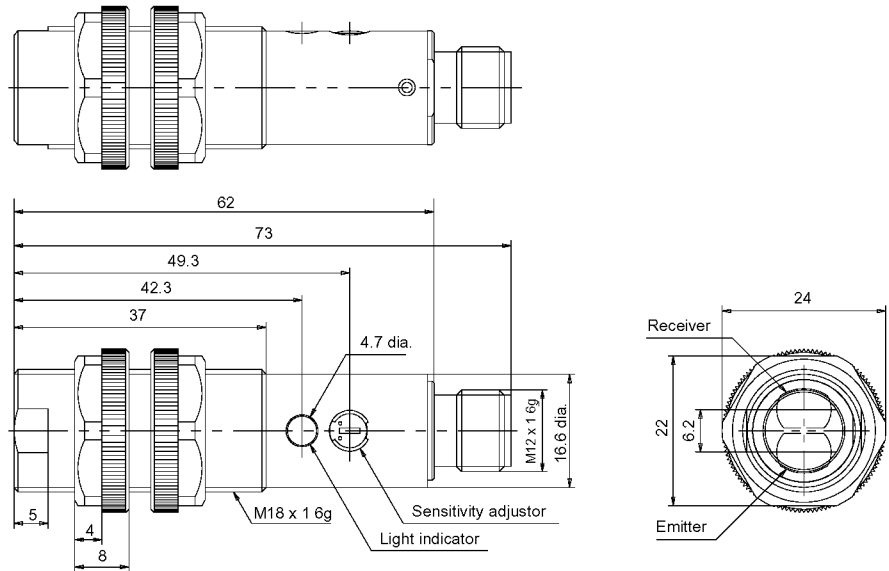

E3F2-7L-M/-C/-S

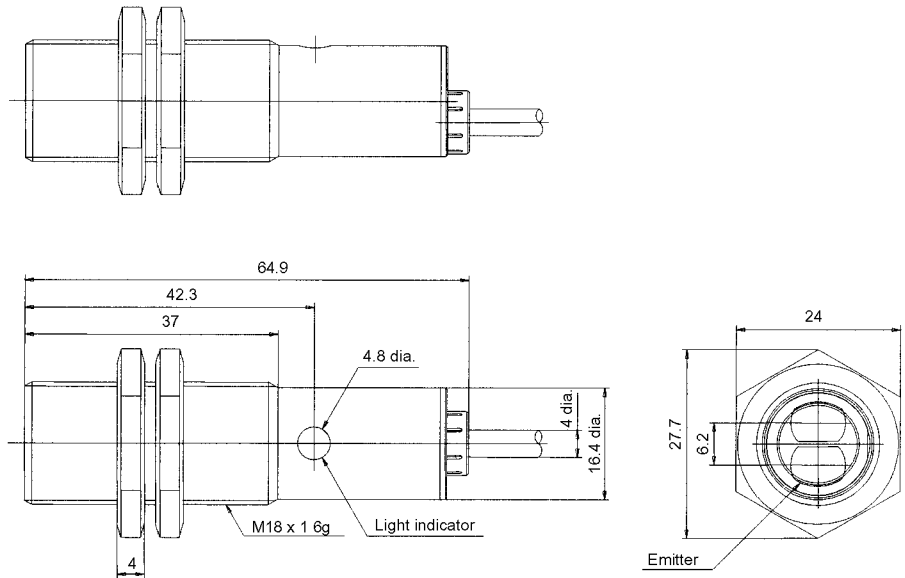

E3F2-7D□4-M/-C/-S

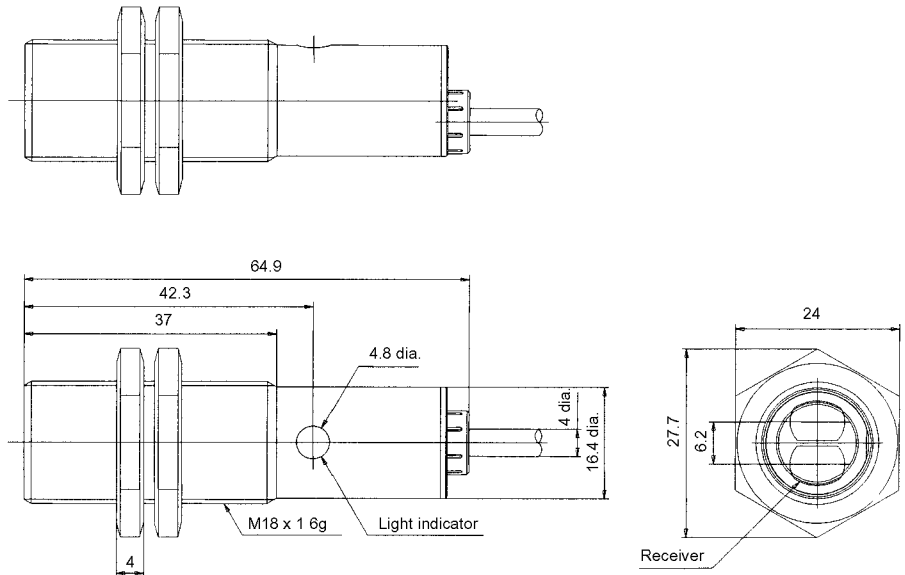

E3F2-R2R□4-M/-C/-S

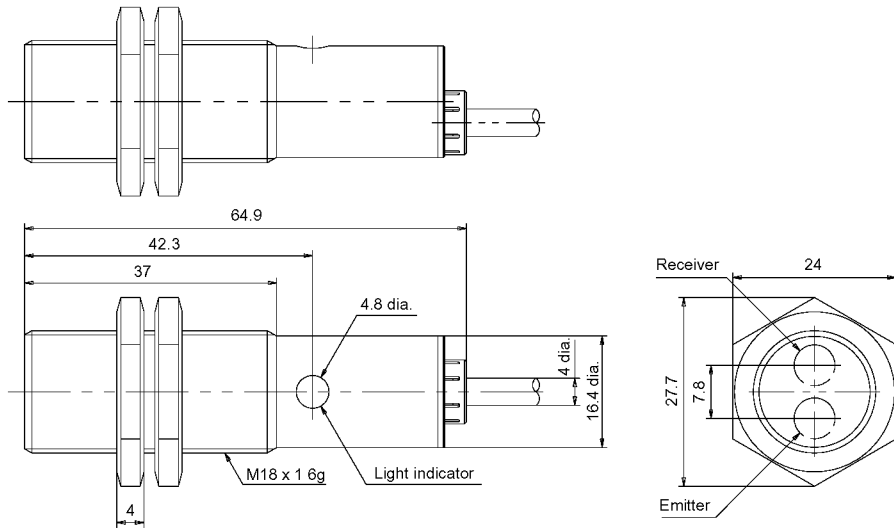

E3F2-DS10□4-M/-C/-S

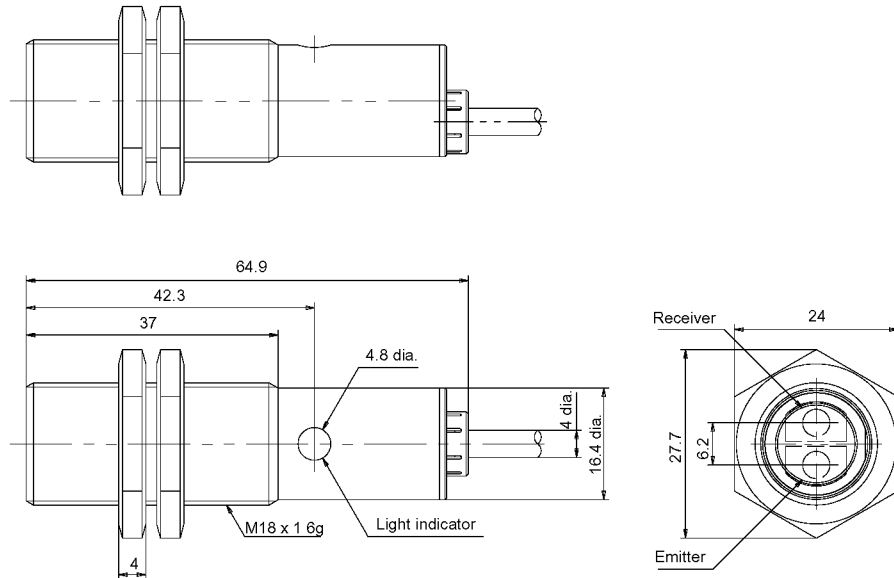

E3F2-DS30□4-M/-S

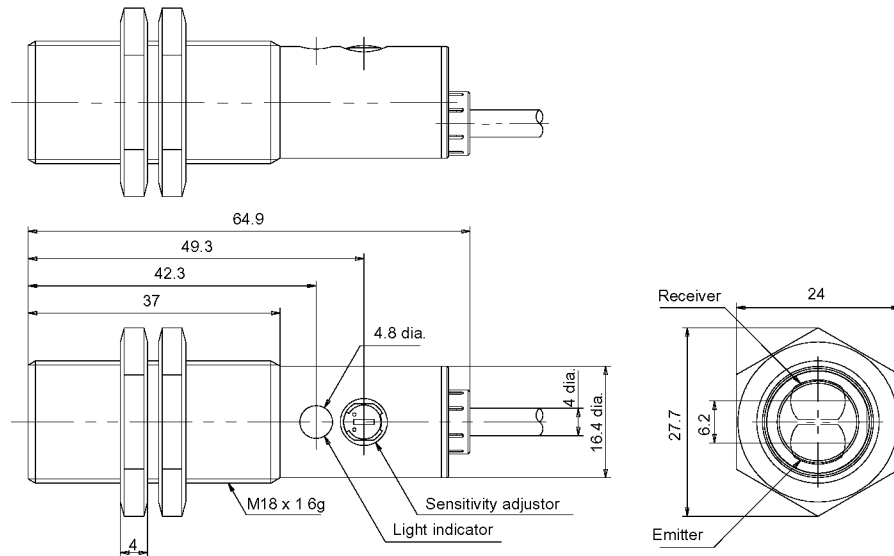

E3F2-7L-M1-M-M1-C-M1-S

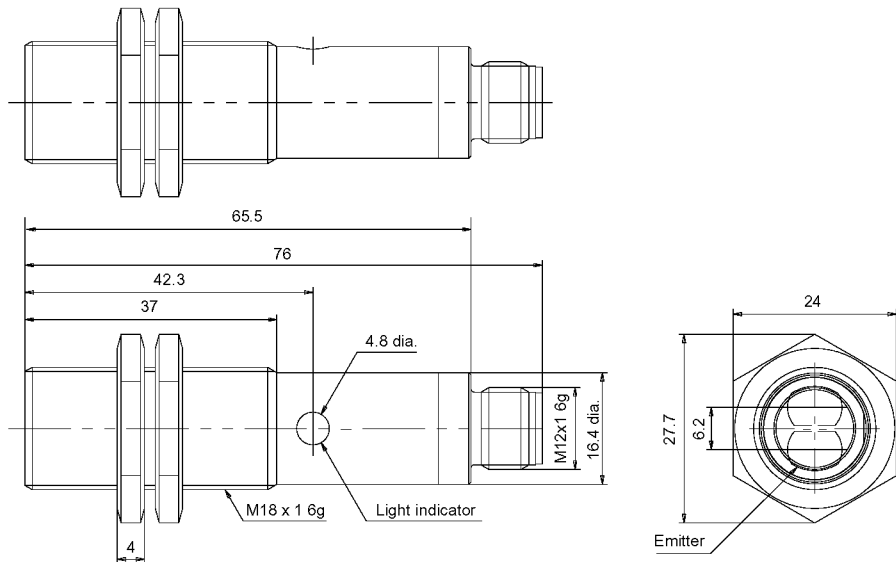

E3F2-7D□4-M1-M-M1-C-M1-S

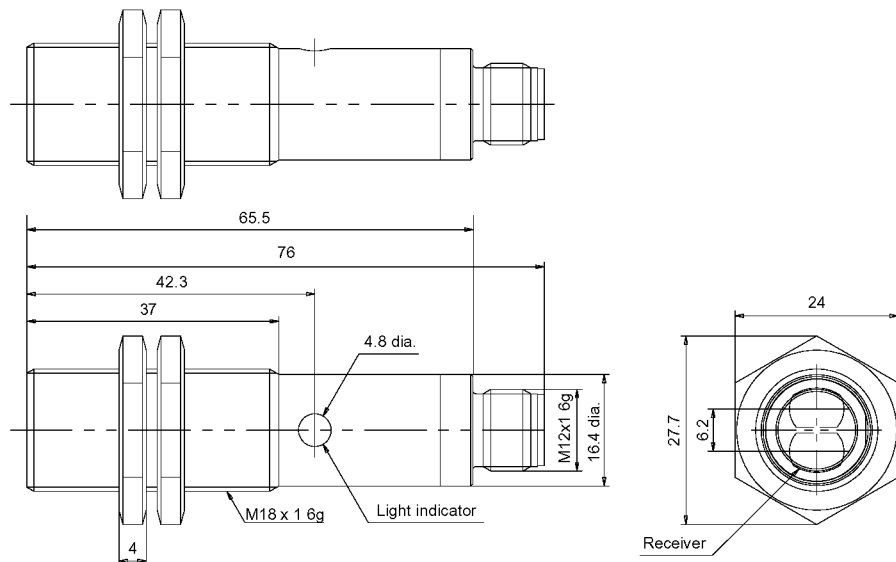

E3F2-R2R□4-M1-M-M1-C-M1-S

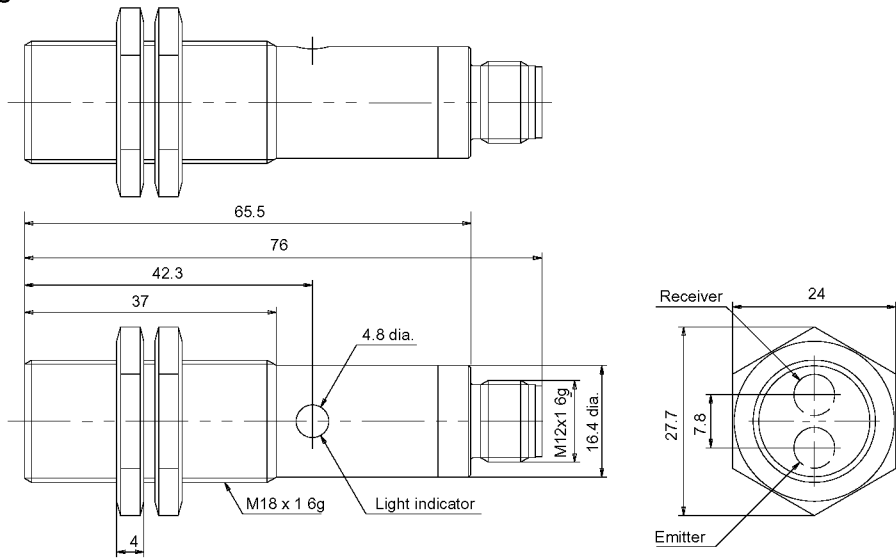

E3F2-DS10□4-M1-M/-M1-C/-M1-S

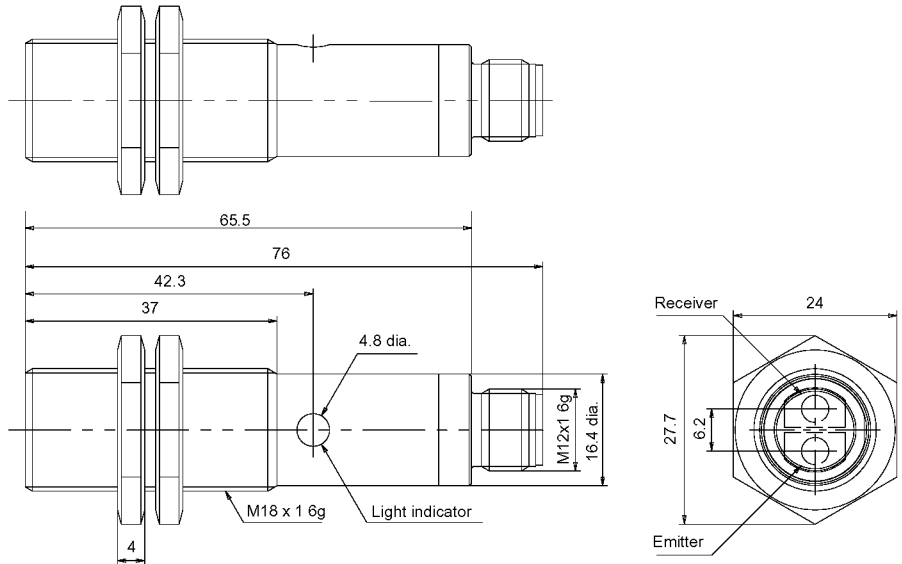

E3F2-DS30□4-M1-M/-M1-S

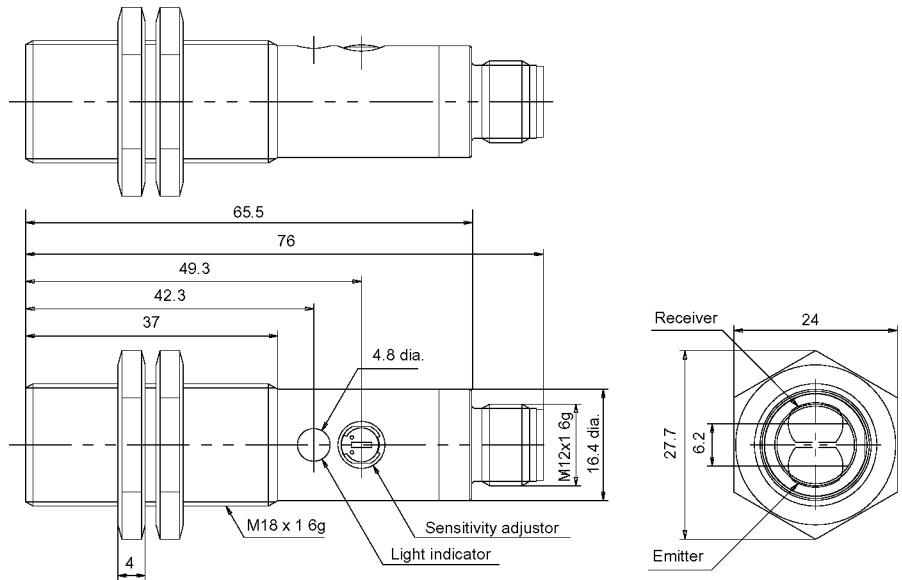

AC Switching Models

E3F2-3Z1, E3F2-3Z2
(Light Source and Receiver)

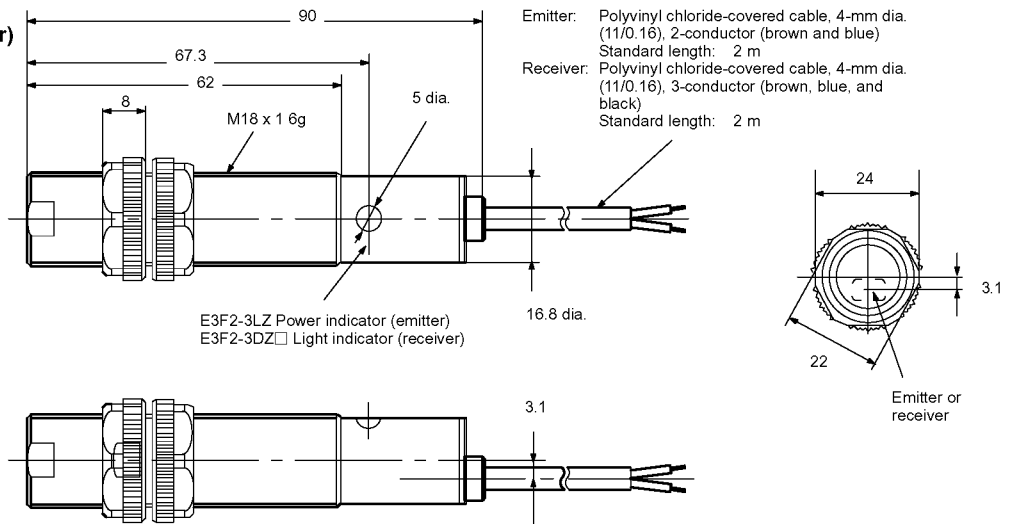

E3F2-R2Z1, E3F2-R2Z2
E3F2-DS10Z1-N,
E3F2-DS10Z2-N

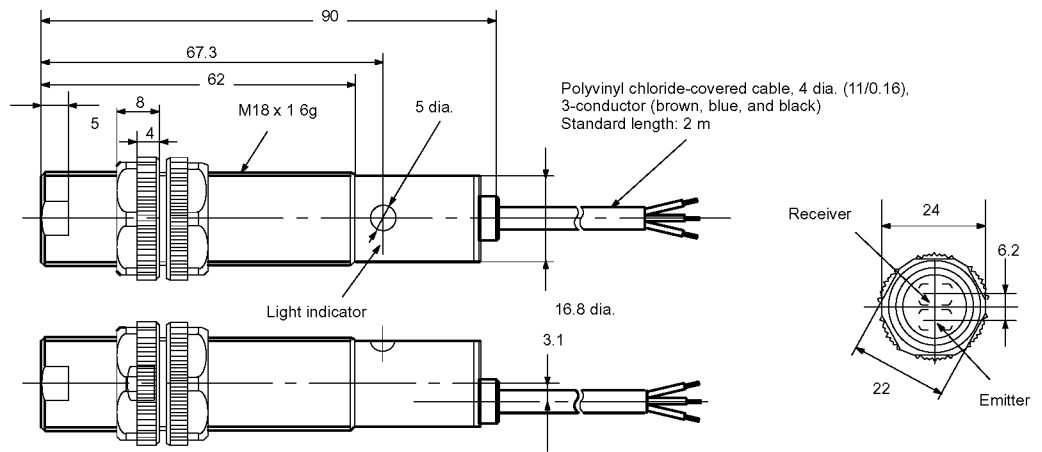

Accessories (Order Separately)

E39-R1 Retroreflector

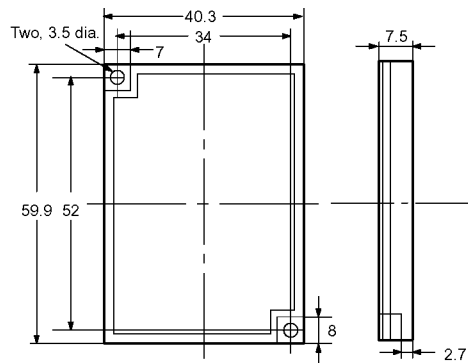
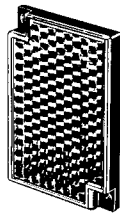

E39-R3 Retroreflector

Mounting Bracket for E39-R3
(Sold Together)

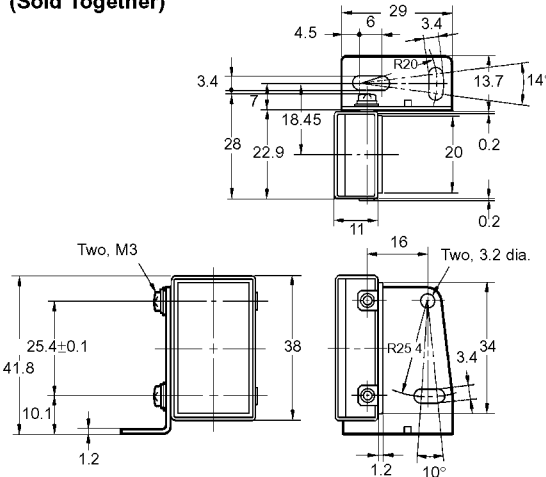
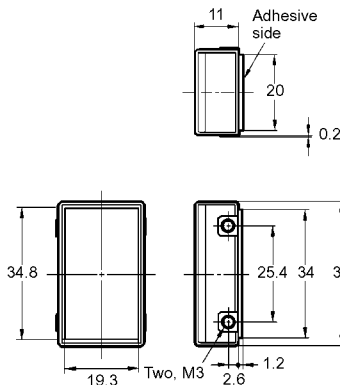

E39-RSA Retroreflector

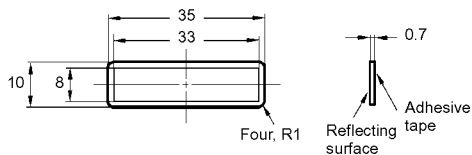

E39-RSB Retroreflector

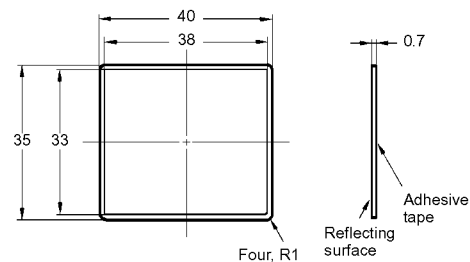

Note: When connected to the E3F2-R2, the sensing distance for each Retroreflector will differ as seen below.

| Retroreflector | E39-R3 | E39-RSA | E39-RSB |
|------------------|-------------|-------------|-------------|
| Sensing distance | 5 to 100 cm | 20 to 50 cm | 20 to 80 cm |

Y92E-B18 Mounting Bracket

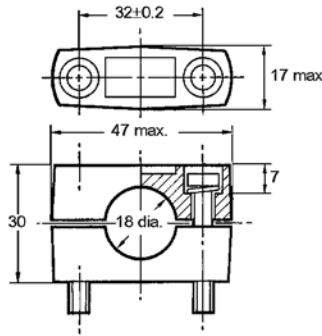
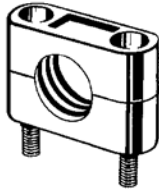

Note: Hexagonal bolt: M5 x 32
Material: plastic

E39-F31 Lens Cap

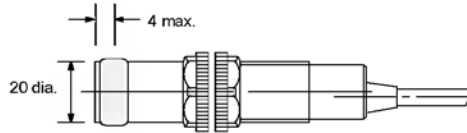
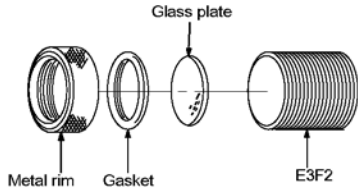

Precautions

If the input/output lines of the Photoelectric Sensor are placed in the same conduit or duct as power lines or high-voltage lines, the Photoelectric Sensor could be induced to malfunction, or even be damaged, by electrical noise. Separate the wiring, or use shielded lines as input/output lines to the Photoelectric Sensor.

Do not subject the Photoelectric Sensor to excessive shock when mounting, in keeping with IEC60529 IP66 standards.

Do not connect the black wire to the brown wire without a load. Direct connection of these wires may damage the Photoelectric Sensor (AC switching type).

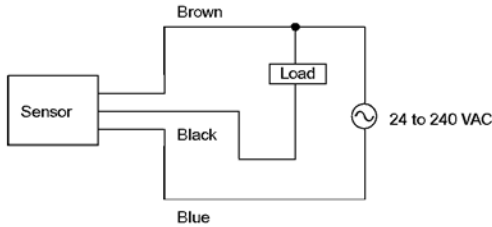

When you use the Photoelectric Sensor at temperatures over 45°C, the load current must be within the rated value shown in the figure below.

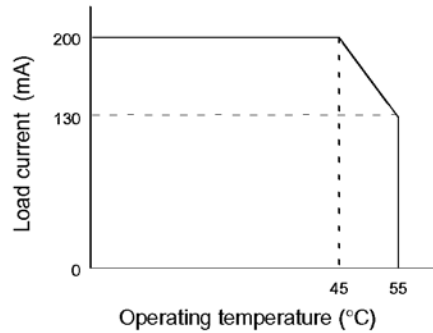

Mounting

Do not exceed a torque of

- 2.0 N • m when tightening mounting nuts for plastic models.
- 20.0 N • m when tightening mounting nuts for metal models.

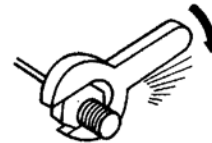

WARNING

The E3F2 Photoelectric Sensor is not a safety component for ensuring the safety of people which is defined in EC Directive (91/368/EEC) and covered by separate European standards or by any other regulations or standards.

When you use the Photoelectric Sensor in the vicinity of an inverter motor, be sure to connect the protective earth ground wire of the motor to earth. Failure to ground the motor may result in malfunction of the Sensor.

ALL DIMENSIONS SHOWN ARE IN MILLIMETERS.

To convert millimeters into inches, multiply by 0.03937. To convert grams into ounces, multiply by 0.03527.

Cat. No. E224-E1-6 In the interest of product improvement, specifications are subject to change without notice.

OMRON Corporation

Industrial Automation Company

Industrial Sensors Division
Sensing Devices and Components Division H.Q.
28th Fl., Crystal Tower Bldg.,
1-2-27, Shiromi, Chuo-ku,
Osaka 540-6028 Japan
Phone: (81)6-6949-6012 Fax: (81)6-6949-6021

Printed in Japan
0699-3M (A)

**Stable Detection Regardless of Color, Material, or Size.
New Optical System to Eliminate Background Influences**

- Background influences are eliminated by a unique optical system for setting the detection distance: 2% or less differential travel at 20 cm.
- Solves traditional problems in diffuse reflective sensors: No distance change for colors or materials; 2% or less black/white error at 20 cm.
- New optical system resists the effect of dirty lenses.
- Easy distance adjustments with 6-turn adjustment with indicator.
- Compact and with a long detection distance of 50 cm (E3S-CL2).
- Solid metallic body with excellent water and oil resistivity (E3S-CL2).
- NPN/PNP output (switch selectable) for easy application anywhere.
- Conforms to relevant EN/IEC standards.

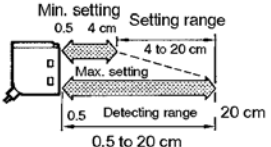
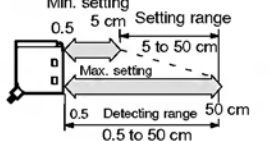

Ordering Information

| Appearance | Detecting/Setting range | Operating mode | Output configuration | Model |
|---|---|-------------------------------------|----------------------------|---------|
|  |  | Light-ON Dark-ON (selectable) | NPN PNP (selectable) | E3S-CL1 |
| |  | | | E3S-CL2 |

Application Examples

E3S-CL1

Detecting Milk Cartons

Stable detection is not affected by stainless steel background or carton colors.

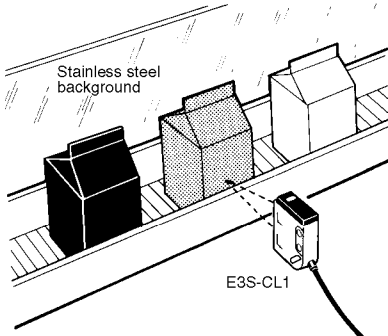

Detecting Food Products on Conveyors

Overhead detection is possible.

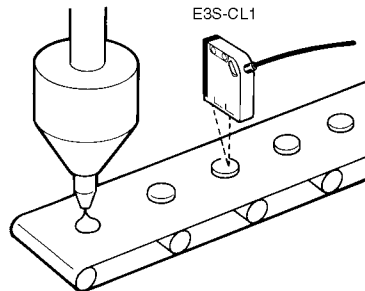

Detecting Wafer Cassettes

Easy distance setting with 6-turn adjustment and indicator.

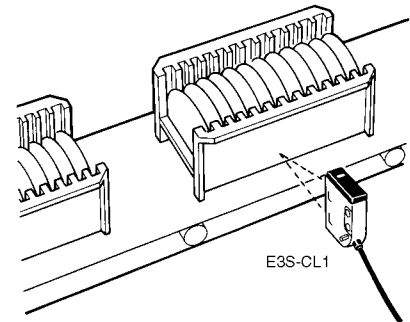

E3S-CL2

Detecting Boxes

Stably detecting boxes regardless of box position.

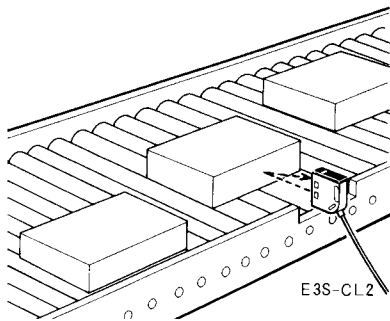

Detecting Construction Materials (Boards) Remaining on a Pallet

Detecting construction materials with the sensor located above the construction materials.

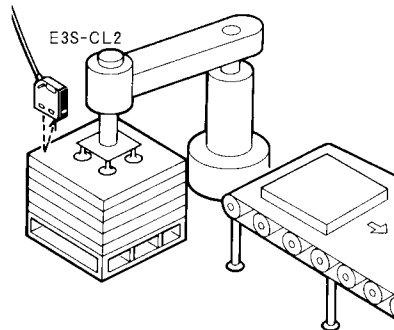

Detection Tires on a Conveyor Line

Stably detecting black objects such as tires.

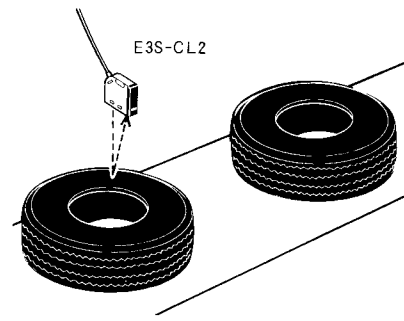

Specifications

| Item | Distance-settable Photoelectric Sensor | |
|------------------------|--|-----------------------------------|
| | E3S-CL1 | E3S-CL2 |
| LED for emitter | Red LED (wavelength: 700 nm) | Infrared LED (wavelength: 860 nm) |
| Sensitivity adjustment | Six-turn endless adjuster with an indicator | |
| Connection method | Pre-wired | |
| Output configuration | NPN or PNP (selectable) open collector current output | |
| Control output | Light-ON or Dark-ON (selectable) | |
| Circuit protection | Load short-circuit protection, reversed connection protection, and mutual interference prevention function | |
| Indicator | Light indicator (orange), stability indicator (green) | |
| Materials | Case: Zinc die-cast Operation panel: Sulfonated polyether Lens: Acrylic Mounting bracket: Stainless | |
| Weight | Approx. 120 g (with 2-mm cable) | |
| Attachments | Mounting bracket, screwdriver for adjustment, M4 hexagonal bolts, and instruction sheet | |

■ Ratings/Characteristics

| Item | E3S-CL1 | E3S-CL2 |
|---|---|---|
| Power supply voltage | 10 to 30 VDC; ripple: 10% max. | |
| Current consumption | 35 mA max. | 50 mA max. |
| Setting distance | 4 to 20 cm (white paper: 20 x 20 cm) | 5 to 50 cm (white paper: 20 x 20 cm) |
| Detection distance | 0.5 to 20 cm (white paper: 20 x 20 cm, setting distance: 20 cm) | 0.5 to 50 cm (white paper: 20 x 20 cm, setting distance: 50 cm) |
| Hysteresis | 2% max. of detection distance | 10% max. of detection distance (5% for white paper) |
| Reflectivity characteristics (black/white error) (see note 1) | 2% max. (at 20-cm detection distance) | 10% max. of detection distance |
| Spot size | 20-mm diameter or less (at 20-cm detection distance) | 30-mm diameter or less (at 20-cm detection distance) |
| Repeat accuracy | Perpendicular to optical axis: 0.5 mm max.; In direction of optical axis: 1 mm max. | Perpendicular to optical axis: 0.5 mm max.; In direction of optical axis: 10 mm max. |
| Response time | 1 ms max. for both operation and release | |
| Control output | 100 mA max. at 30 VDC (residual voltage; NPN output: 1.2 V max., PNP output: 2.0 V max.) (NPN/PNP output selectable) | |
| Ambient illumination | Incandescent lamp: illumination on optical spot: 5,000 lx max. Sunlight: illumination on optical spot: 10,000 lx max. | |
| Ambient temperature | Operating: -25°C to 55°C (with no icing) | |
| Ambient humidity | Operating: 35% to 85% | |
| Insulation resistance | 20 MΩ min. (at 500 VDC) | |
| Dielectric strength | 1,000 VAC, 50/60 Hz for 1 min | |
| Vibration resistance | Destruction: 10 to 55 Hz, 1.5-mm double amplitude, or 300 m/s ² (approx. 30G) for 2 hrs each in X, Y, and Z directions | |
| Shock resistance | Destruction: 500 m/s ² (approx. 50G) 3 times each in X, Y, and Z directions | |
| Enclosure ratings | IEC: IP67, NEMA: 6P (indoors only) (see note 2) | IEC: IP67 (JEM: IP67G), NEMA: 6P (indoors only) (see note 2) |

Note: 1. Detection distance error for standard white (90% reflective) and black (5% reflective) paper.
2. NEMA: National Electrical Manufacturers Association

Engineering Data

Detection Distance vs. Object Size

E3S-CL1

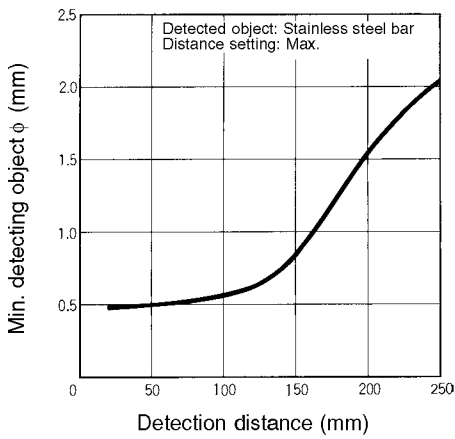

E3S-CL2

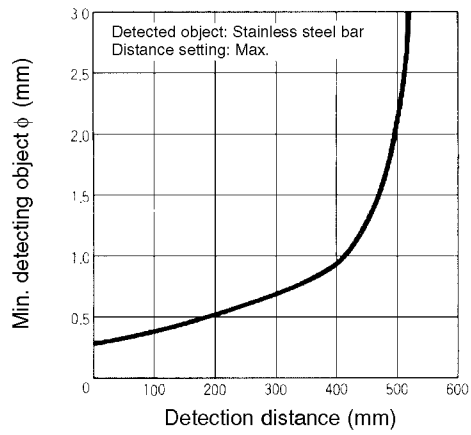

Spot Diameter vs. Detection Distance

E3S-CL1

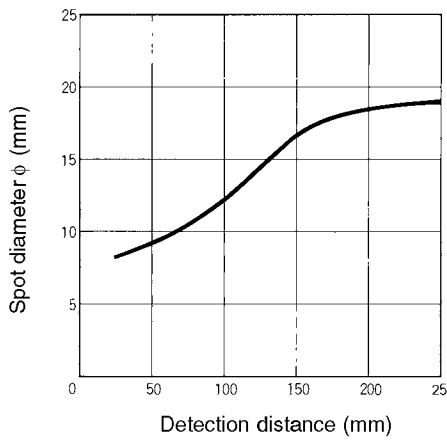

E3S-CL2

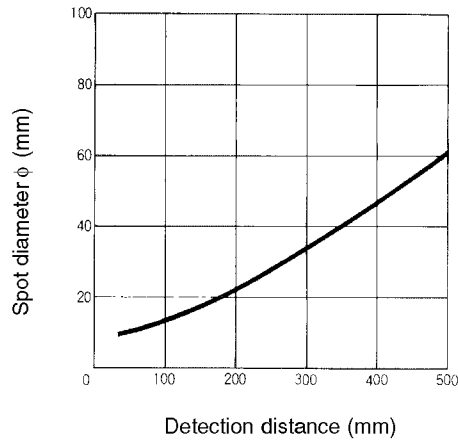

Operating Range

E3S-CL1

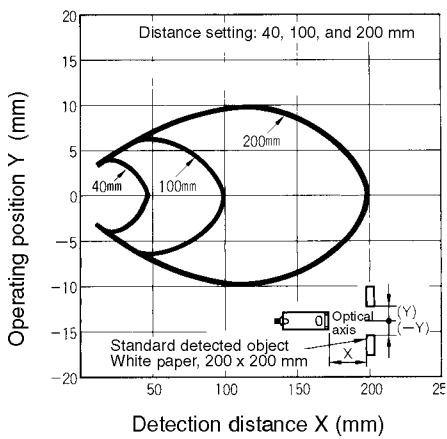

E3S-CL2

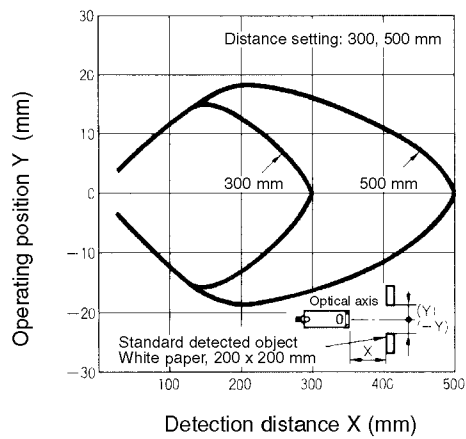

Detection Distance vs. Object Size

E3S-CL1

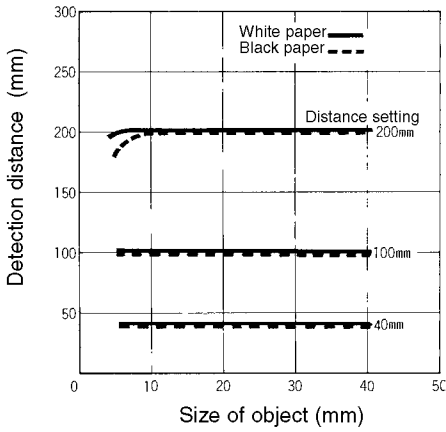

E3S-CL2

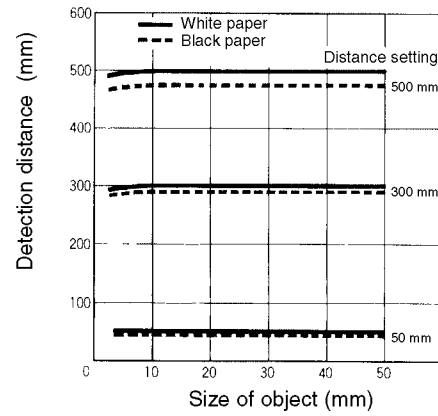

Angle Characteristic

E3S-CL1

Vertical Detection

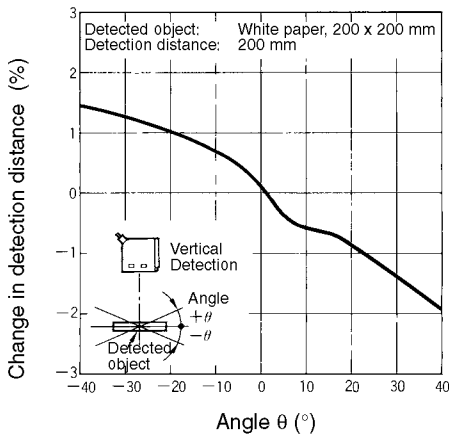

E3S-CL1

Horizontal Detection

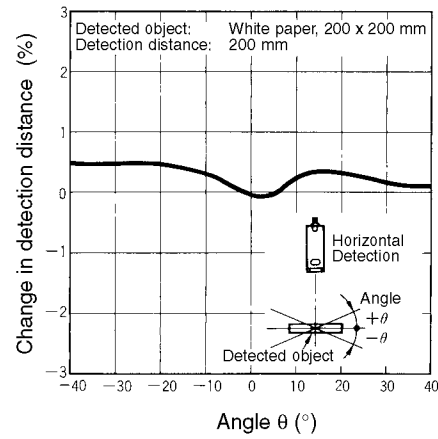

E3S-CL2

Vertical Detection

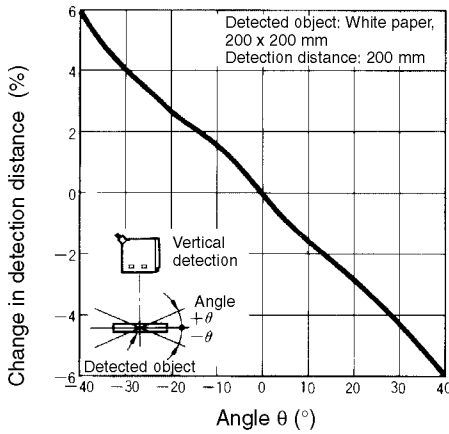

E3S-CL2

Horizontal Detection

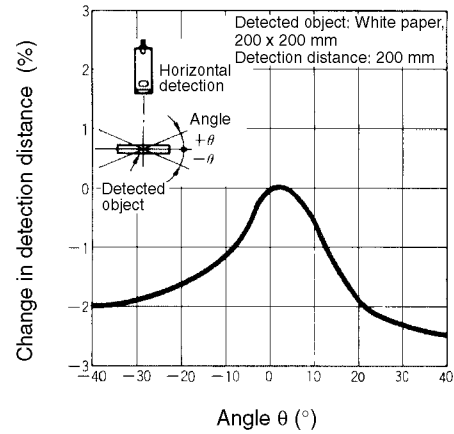

Detection Distance vs. Material

E3S-CL1

(Setting Distance Set to 200 mm using White Paper)

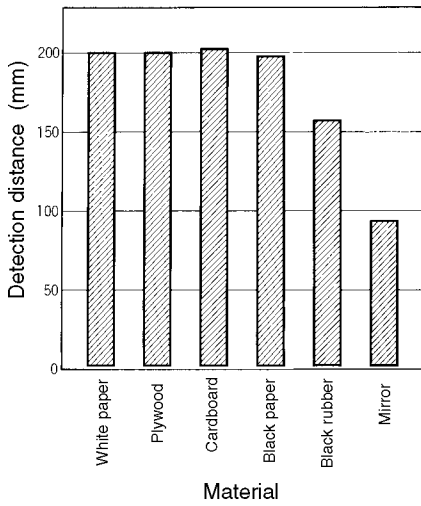

(Setting Distance Set to 100 mm using White Paper)

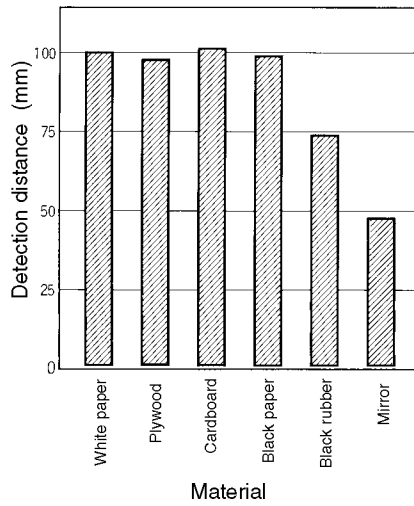

(Setting Distance Set to 40 mm using White Paper)

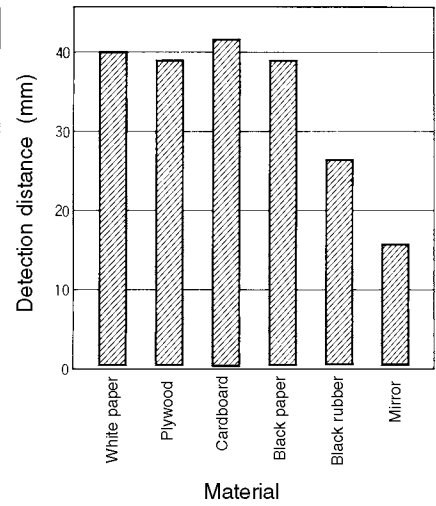

E3S-CL2

(Setting Distance Set to 500 mm using White Paper)

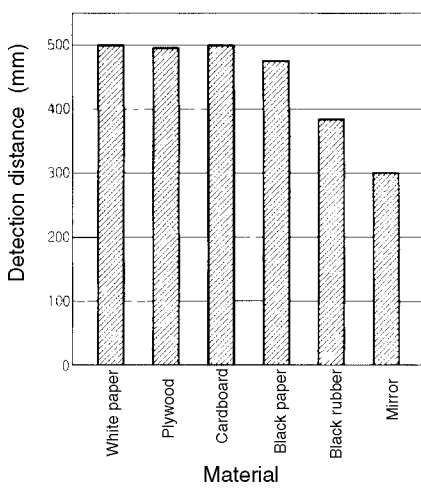

(Setting Distance Set to 300 mm using White Paper)

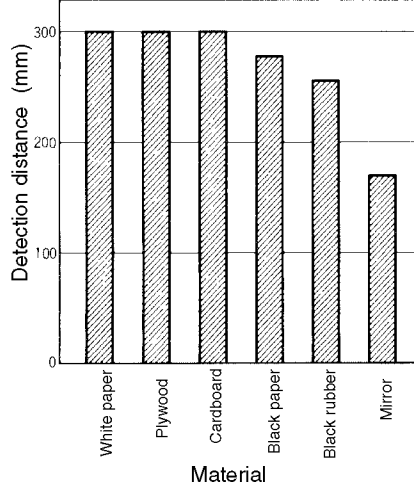

(Setting Distance Set to 50 mm using White Paper)

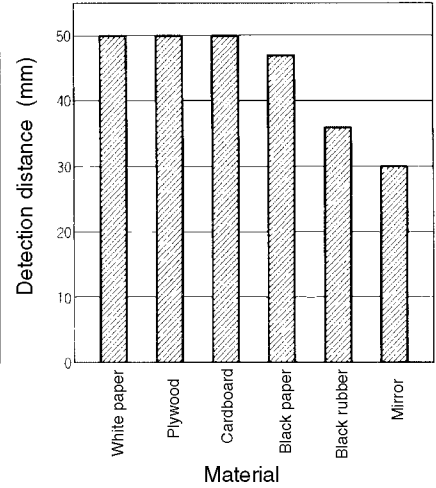

Short Range Characteristic

E3S-CL1

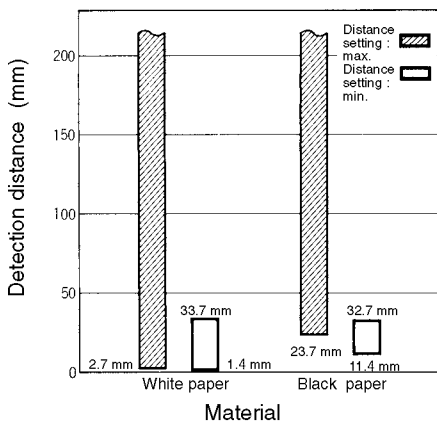

E3S-CL2

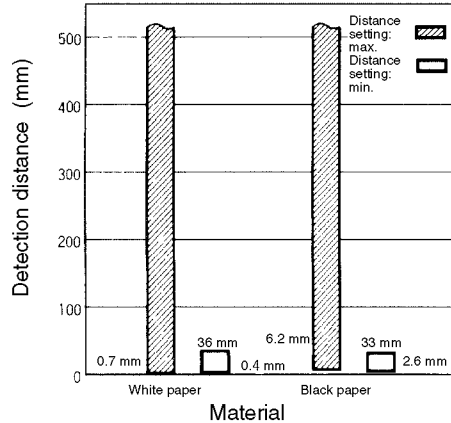

Nomenclature

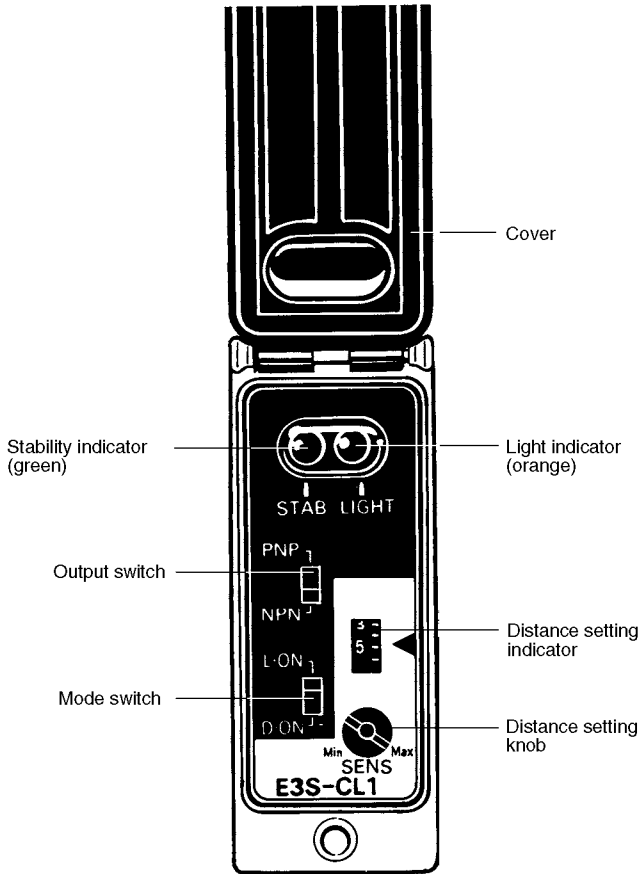

Output Switch

1. Set the switch to NPN for NPN output.
2. Set the switch to PNP for PNP output.

Mode Switch

1. Set the switch to L-ON for ON light-ON operation.
2. Set the switch to D-ON for ON dark-ON operation.

Distance Setting Knob

1. The detection distance will increase when the knob is turned clockwise (toward Max.) and will decrease when the knob is turn counterclockwise.
2. The adjustment can be turned up to 6 times clockwise or counterclockwise to set the detection distance. The number of turns will be displayed by the indicator.

Operation

Output Circuits

| Output configuration | Mode switch | Output transistor | Output circuits |
|----------------------|-------------|--------------------------------|-----------------------|
| NPN | Light-ON | ON when light is received. | <p>ZD : Vz = 39 V</p> |
| | Dark-ON | ON when light is not received. | |
| PNP | Light-ON | ON when light is received. | <p>ZD : Vz = 39 V</p> |
| | Dark-ON | ON when light is not received. | |

■ Timing Chart

| Output configuration | Mode switch | Output transistor | Timing chart |
|----------------------|-------------|--------------------------------|---|
| NPN | Light-ON | ON when light is received. | Light received Light not received Light indicator (Orange) ON OFF Output transistor ON OFF Load (relay) Operate Release |
| | Dark-ON | ON when light is not received. | Light received Light not received Light indicator (Orange) ON OFF Output transistor ON OFF Load (relay) Operate Release |
| PNP | Light-ON | ON when light is received. | Light received Light not received Light indicator (Orange) ON OFF Output transistor ON OFF Load (relay) Operate Release |
| | Dark-ON | ON when light is not received. | Light received Light not received Light indicator (Orange) ON OFF Output transistor ON OFF Load (relay) Operate Release |

■ Sensitivity Adjustment

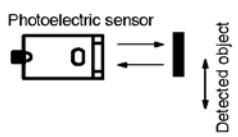
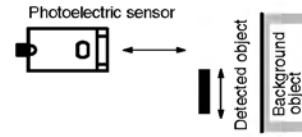
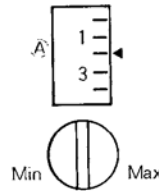
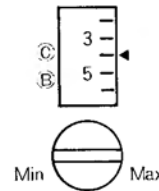
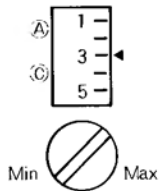
| Item | Position A | Position B and C | Setting |
|---|---|--|--|
| Adjustment procedure | Place the detected object at the desired location and turn the adjustment knob clockwise until the LIGHT indicator (orange) lights. This is position A. | Background Object Remove the detected object and turn the adjustment knob clockwise until the LIGHT indicator (orange) lights. This is position B. Then turn the adjustment knob counterclockwise until the LIGHT indicator (orange) goes out. This is position C. No Background Object The maximum adjustment setting is used as position C. | Set the adjustment to halfway between A and C. Confirm that the STAB indicator (green) remains lit both with the detected object present and not present. If the STAB indicator does not remain lit, reconsider the detection method to enable stable operation. |
| Detecting condition |  |  | --- |
| Status of distance setting knob and distance setting indicator |  |  |  |
| Indicators | OFF STABILITY (green) ON LIGHT (orange) | OFF STABILITY (green) OFF LIGHT (orange) | ON STABILITY (green) OFF LIGHT (orange) |

Note: The sensor must be set to within the rated detection range for application (see diagrams on next page).

Background interference can be a problem if the distance is set near the maximum value (5 to 6 on the scale). Factory settings are as follows:

E3S-CL1: 20 cm (on white paper)

E3S-CL2: 50 cm (on white paper)

Set Distance Indicator Scale vs. Detection Distance Characteristic (Typical)

E3S-CL1

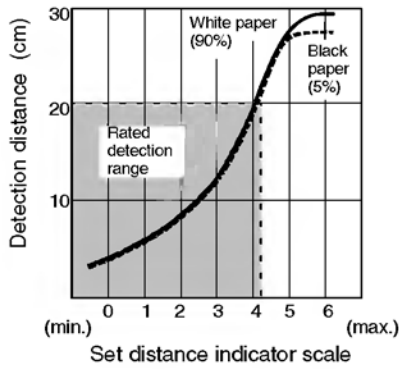

E3S-CL2

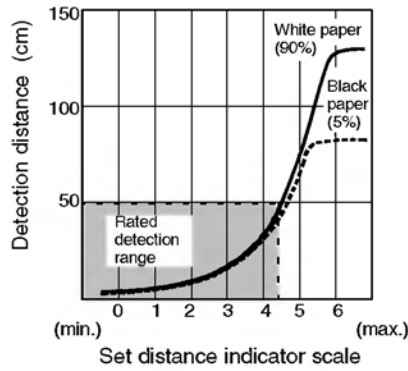

Note: Reflection rates are given in parentheses.

Dimensions

Note: All units are in millimeters unless otherwise indicated.

E3S-CL1

E3S-CL2

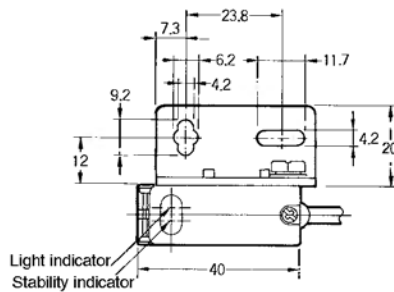
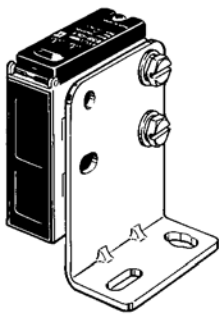

Mounting Holes

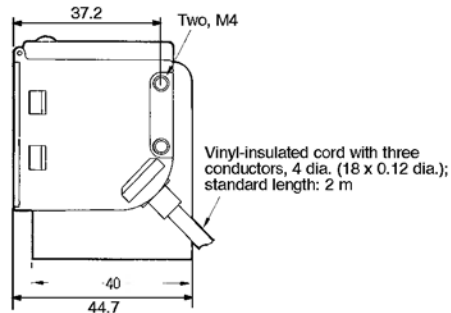
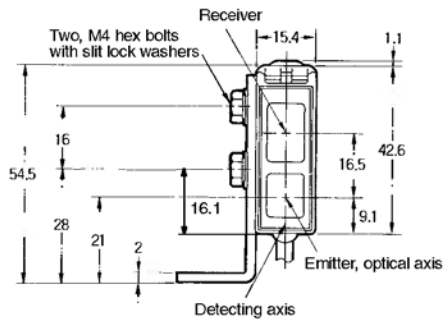
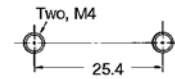

Note: The output switch, mode switch, and distance setting knob can be accessed by removing the cover.

Installation

■ Connections

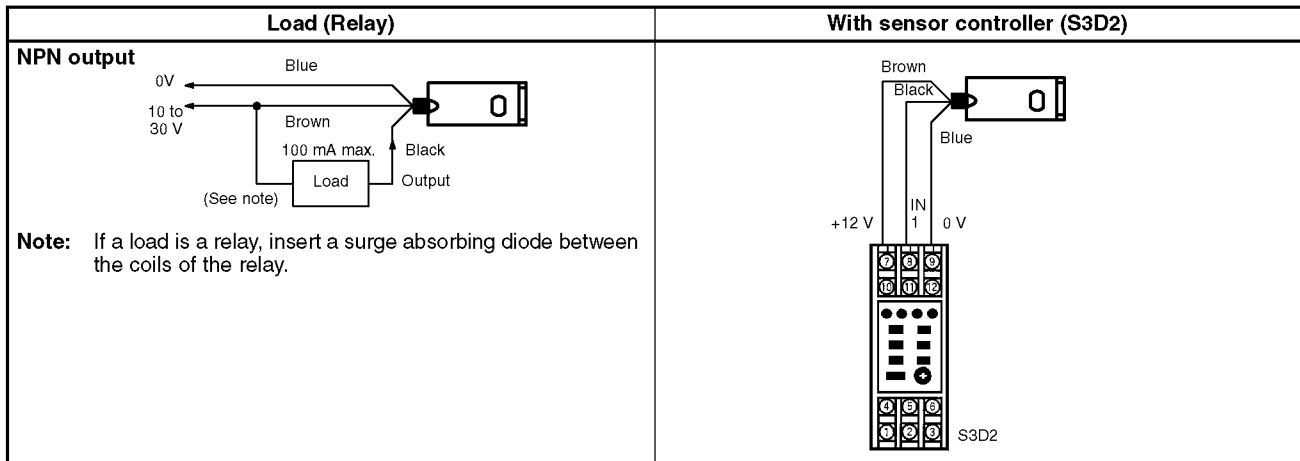

Precautions

Connection

If the input/output lines of the photoelectric sensor are placed in the same conduit or duct as power lines or high-voltage lines, the photoelectric sensor could be induced to malfunction, or even be damaged, by electrical noise. Either separate the wiring or use shielded lines as input/output lines to the photoelectric sensor.

The cord connected to the Sensor can be extended up to 100 m provided that the diameter of each wire of the cord is 0.3 mm² minimum.

Power Supply

If a standard switching regulator is used as a power supply, the frame ground (FG) terminal and the ground (G) terminal must be grounded, otherwise the Sensor may malfunction due to the switching noise of the power supply.

Startup Operation

A maximum of 100 ms is required from the time power is turned on until the E3S-CL is able to detect objects. If power is supplied to the loads and the E3S-CL from different sources, turn on power to the E3S-CL first.

Water Resistivity

Do not use the E3S-CL in water, in the rain, or outdoors.

To ensure the water resistivity of the E3S-CL, tighten the screws of the operation panel cover to a torque of 2.5 to 5.0 kgf • cm (0.25 N • m to 0.49 N • m).

Oil and Chemical Resistivity (E3S-CL2)

| Oil | JIS classification | Product name | Kinematic viscosity (mm ² /s (cst) at 40°C | PH |
|-------------------------------|--------------------|-----------------------|---|----------|
| Lubricating oil | --- | Velocite No.3 | 2.02 | --- |
| Water insoluble machining oil | No. 5, type 2 | Daphnecut | 10 min. and less than 50 | |
| | No. 11, type 2 | Yushiron Oil No. 2 ac | Less than 10 | |
| Water soluble machining oil | No. 1, type W1 | Yushiroken EC50T-3 | --- | 7 to 9.5 |
| | | Yushiron Lubic HWC68 | | 7 to 9.9 |
| | No. 2, type W1 | Griton 1700D | | 7 to 9.2 |
| | No. 1, type W2 | Yushiroken S50N | | 7 to 9.8 |

- Note:**
- The E3S-CL2 maintained a minimum insulation resistance of 100 MΩ after the E3S-CL2 was dipped in all the above oils at a temperature of 50°C for 240 hours.
 - When using the E3S-CL2 in a place where an oil other than the ones listed above is sprayed on the E3S-CL2, refer to the above kinematic viscosity and pH values. The location may be suitable for the E3S-CL2 if the kinematic viscosity and pH values of the oil are close to the above kinematic viscosity and pH values, but make sure that the oil does not contain any additive that may have a negative influence on the E3S-CL2.
 - JIS: Japan Industrial Standards

Do not use an E3S-CL2 that has been dipped in oil or chemical liquid.

The E3S-CL2 passed oil-resistivity tests with all the oils listed above. Other oils may, however, disrupt the normal operation.

Cable

The E3S-CL2 uses an oil-resistive cord to ensure oil resistivity. Do not allow the cable to be repeatedly bent during application. Do not allow the cable to be bent to a radius of less than 25 mm.

Malfunctioning

If an inverter motor or servomotor is used with the E3S-CL, the frame ground (FG) terminal and the ground (G) terminal must be grounded, or otherwise the Sensor may malfunction.

Mounting

Mounting Direction

Mount the Sensor so that the detection face runs parallel to the surface of the object being detected as shown below, and not at an angle.

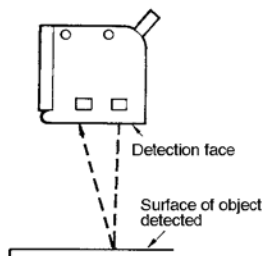

If detecting a shiny object, however, mount the Sensor so that the detection face is at an angle of between 5° and 10° of the surface of the object being detected as shown below, and check to be sure that there is no interference from the background.

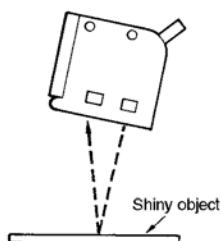

If stable operation is not possible near a mirror surface, mount the Sensor at an angle as shown below, and separate the Sensor as far as possible from the mirror surface.

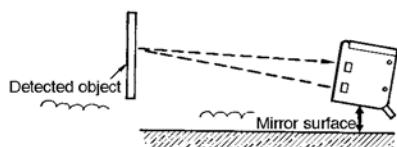

Mount the Sensor so that it is not aligned with the direction of movement of the detected object, as shown below.

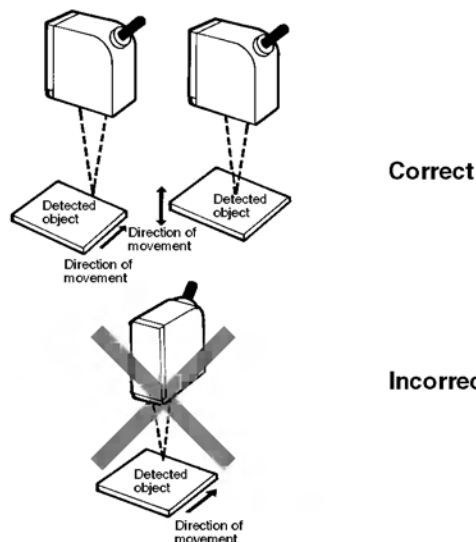

Also, mount the Sensor so that it is not aligned with extreme changes in color or materials, as shown below.

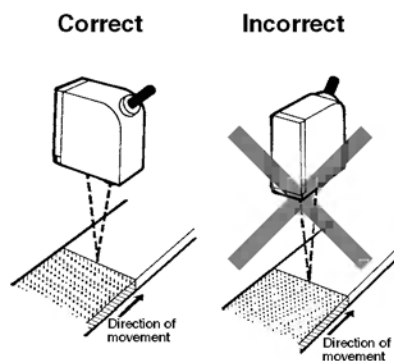

Mount the Sensor so that sunlight, fluorescent light, incandescent light, or other strong sources of light do not enter the directional angle of the Sensor.

Precautions

When mounting the Sensor, do not hit the Sensor with a hammer, or the Sensor will lose its watertightness.

Use M4 screws to mount the Sensor.

The tightening torque of each screw must be $12 \text{ kgf} \cdot \text{m}$ ($1.18 \text{ N} \cdot \text{m}$) maximum.

Direct Mounting

Mount the Sensor as shown in the following illustration.

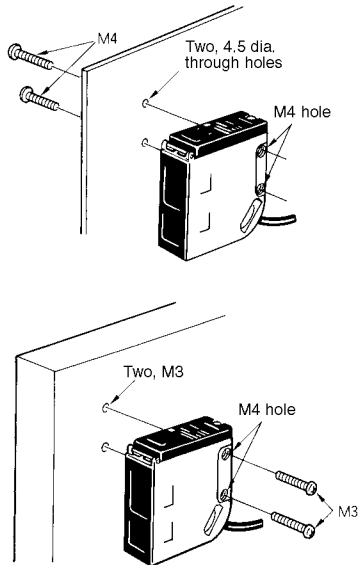
**! WARNING**

The E3S-CL is not a safety component for ensuring the safety of people which is defined in EC directive (91/368/EEC) and covered by separate European standards or by any other regulations or standards.

ALL DIMENSIONS SHOWN ARE IN MILLIMETERS.

To convert millimeters into inches, multiply by 0.03937. To convert grams into ounces, multiply by 0.03527.

Cat. No. E237-E1-2A In the interest of product improvement, specifications are subject to change without notice.

OMRON Corporation

Industrial Sensors Division
Sensing Devices and Components Division H.Q.
28th Fl., Crystal Tower Bldg.
1-2-27, Shiromi, Chuo-ku,
Osaka 540 Japan
Phone: 06-949-6012 Fax: 06-949-6021

Printed in Japan
1297-1M (0395) a

E3X-NA

Super Manual Fiber Amplifier

Sense the Difference, Make a Difference!

Simple and Easy

- Easy operation.
- LED display for incident level.
- Long sensing distance (200 m with reflective models) - double that of standard E3X-NA models.
- High resolution - 7 times that of previous models (e.g., E3X-NA11).
- "Easy wiring" connector.
- Same design as E3X-DA-N Digital Fiber Amplifier.

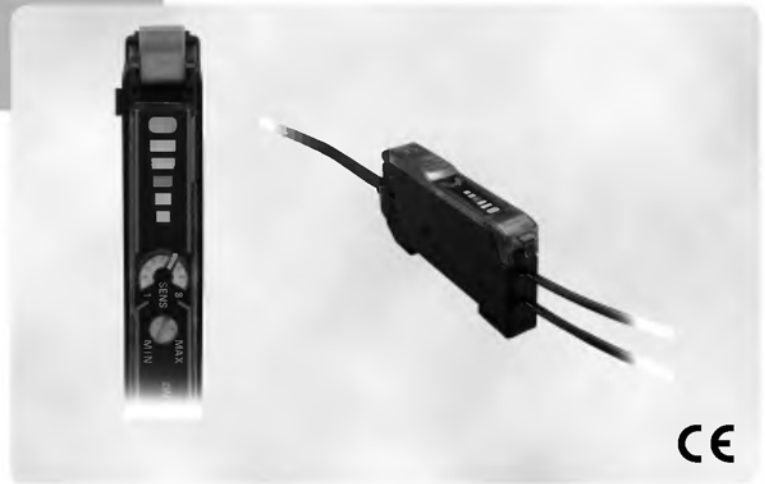

Ordering Information: Amplifier Units, Connectors and Accessories

■ Amplifier Units

Amplifier Units with Cables

| Item | Appearance | Control output | Model | |
|-----------------------------|------------|----------------|------------|------------|
| | | | NPN output | PNP output |
| Standard models | | ON/OFF output | E3X-NA11 | E3X-NA41 |
| High-speed detection models | | | E3X-NA11F | E3X-NA41F |
| Mark-detecting models | | | E3X-NAG11 | E3X-NAG41 |
| Water-resistant models | | | E3X-NA11V | E3X-NA41V |

Amplifier Units with Connectors

| Item | Appearance | Applicable Connector (order separately) | | Control output | Model | |
|--|------------|---|----------|----------------|------------|------------|
| | | | | | NPN output | PNP output |
| Standard models | | Master | E3X-CN11 | ON/OFF output | E3X-NA6 | E3X-NA8 |
| | | Slave | E3X-CN12 | | | |
| Water-resistant models (M8 connectors) | | XS3F-M421-40□-A XS3F-M422-40□-A | | | E3X-NA14V | E3X-NA44V |

■ Amplifier Unit Connectors (Order Separately)

Note Stickers for Connectors are included as accessories.

| Item | Appearance | Cable length | No. of conductors | Model |
|------------------|------------|--------------|-------------------|----------|
| Master Connector | | 2 m | 3 | E3X-CN11 |
| Slave Connector | | | 1 | E3X-CN12 |



■ Combining Amplifier Units and Connectors

Refer to the following tables when placing an order. Basically, Amplifier Units and Connectors are sold separately.

| Amplifier Units | | | + | Applicable Connectors (Order Separately) | |
|-----------------|---------|---------|---|--|-------------------|
| Type | NPN | PNP | | Master Connector | Slave Connector |
| Standard models | E3X-NA6 | E3X-NA8 | | | E3X-CN11 (3-wire) |



| When Using 5 Amplifier Units | | + | 1 Master Connector + 4 Slave Connectors | |
|------------------------------|--|---|---|--|
| Amplifier Units (5 Units) | | | | |

■ Sensor I/O Connectors (Order Separately)

| Size | Cable specifications | Appearance | Cable type | | Model |
|------|----------------------|--|------------|-----------------|-----------------|
| M8 | Standard cable | Straight connector  | 2 m | Four-core cable | XS3F-M421-402-A |
| | | | 5 m | | XS3F-M421-405-A |
| | | L-shaped connector  | 2 m | | XS3F-M422-402-A |
| | | | 5 m | | XS3F-M422-405-A |

■ Accessories (Order Separately)

Mounting Brackets

| Appearance | Applicable models | Model | Quantity |
|---|---------------------------------|----------|----------|
|  | E3X-NA□ E3X-NA□F E3X-NAG□ | E39-L143 | 1 |
|  | E3X-NA□V | E39-L148 | |

End Plate

| Appearance | Model | Quantity |
|---|-------|----------|
|  | PFP-M | 1 |

Specifications: Amplifier Units

■ Ratings/Characteristics

| Item | | Amplifier Units with Cables | | | | Amplifier Units with Connectors | |
|--------------------------------------|------------|--|--|---|--|--|--|
| | | Standard models | High-speed detection models | Mark-detecting models | Water-resistant models | Standard models | Water-resistant models (M8 connectors) |
| Output type | NPN output | E3X-NA11 | E3X-NA11F | E3X-NAG11 | E3X-NA11V | E3X-NA6 | E3X-NA14V |
| | PNP output | E3X-NA41 | E3X-NA41F | E3X-NAG41 | E3X-NA41V | E3X-NA8 | E3X-NA44V |
| Light source (wavelength) | | Red LED (680 nm) | | Green LED (520 nm) | Red LED (680 nm) | | |
| Supply voltage | | 12 to 24 VDC \pm 10%, ripple (p-p): 10% max. | | | | | |
| Current consumption | | 35 mA max. | 35 mA max. (for 24-VDC power supply) | 35 mA max. | | | |
| Control output | | NPN/PNP (depends on model) open collector; load current: 50 mA max.; residual voltage: 1 V max.; Light ON/Dark ON mode selector | | | | | |
| Response time | | 200 μ s max. for operation and reset respectively (See note.) | Operation: 20 μ s max. Reset: 30 μ s max. | 200 μ s max. for operation and reset respectively (See note.) | | | |
| Sensitivity adjustment | | 8-turn sensitivity adjuster (with indicator) | | | | | |
| Circuit protection | | Reverse polarity, output short-circuit, mutual interference prevention (optically synchronized) | Reverse polarity, output short-circuit | Reverse polarity, output short-circuit, mutual interference prevention (optically synchronized) | | | |
| Timer function | | OFF-delay timer: 40 ms (fixed) | | | | | |
| Ambient illumination (receiver side) | | Incandescent lamp: 10,000 lux max. Sunlight: 20,000 lux max. | | | | | |
| Ambient temperature | | Operating: Groups of 1 to 3 Amplifiers: -25°C to 55°C Groups of 4 to 11 Amplifiers: -25°C to 50°C Groups of 12 to 16 Amplifiers: -25°C to 45°C (with no icing or condensation) Storage: -30°C to 70°C (with no icing or condensation) | | | | | |
| Ambient humidity | | Operating and storage: 35% to 85% (with no condensation) | | | | | |
| Insulation resistance | | 20 M Ω min. (at 500 VDC) | | | | | |
| Dielectric strength (destruction) | | 1,000 VAC at 50/60 Hz for 1 minute | | | | | 500 VAC at 50/60 Hz for 1 minute |
| Vibration resistance (destruction) | | 10 to 55 Hz with a 1.5-mm double amplitude for 2 hrs each in X, Y and Z directions | | | | | |
| Shock resistance (destruction) | | 500 m/s ² , for 3 times each in X, Y and Z directions | | | | | |
| Enclosure rating | | IEC60529 IP50 (with Protective Cover attached) | | | IEC60529 IP66 (with Protective Cover attached) | IEC60529 IP50 (with Protective Cover attached) | IEC60529 IP66 (with Protective Cover attached) |
| Connection method | | Pre-wired (standard cable length: 2 m) | | | | Connector | M8 connector |
| Weight (packed state) | | Approx. 100 g | | | Approx. 110 g | Approx. 55 g | Approx. 65 g |
| Material | Case | Polybutylene terephthalate (PBT) | | | | | |
| | Cover | Polycarbonate | | | Polyethersulfone (PES) | Polycarbonate | Polyethersulfone (PES) |
| Accessories | | Instruction Sheet | | | | | |

Note When there are 8 or more Units mounted side-by-side, the response time will be 350 μ s max.

■ Amplifier Unit Connectors



| Item | | E3X-CN11 | E3X-CN12 |
|------------------------------------|---------|---|--------------|
| Rated current | | 2.5 A | |
| Rated voltage | | 50 V | |
| Contact resistance | | 20 m Ω max. (20 mVDC max., 100 mA max.) (The above figure is for connection to the Amplifier Unit and the adjacent Connector. It does not include the conductor resistance of the cable.) | |
| Number of insertions (destruction) | | 50 times (for connection to the Amplifier Unit and the adjacent Connector) | |
| Material | Housing | Polybutylene terephthalate (PBT) | |
| | Contact | Phosphor bronze/gold-plated nickel | |
| Weight (packed state) | | Approx. 55 g | Approx. 25 g |







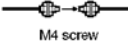
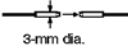
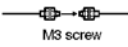
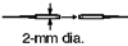
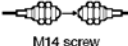
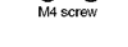
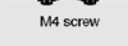
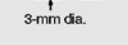
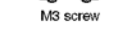
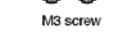



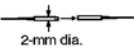

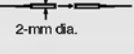

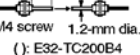

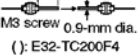

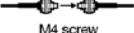
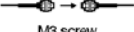
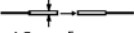
Ordering Information: Fiber Units

■ Through-beam Fiber Units







Refer to the end of the following table for notes and precautions.

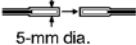

(Free-cut) Indicates models that allow free cutting. Models without this mark do not allow free cutting. : Red light : Green light

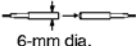
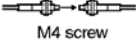
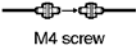
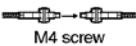
| Application | Features | Appearance | Applicable Amplifier Unit | Sensing distance (mm) (Values in parentheses: when using the E39-F1 Lens Unit) | Standard object (see notes) (min. sensing object: opaque) | Model | Permissible bending radius |
|---|--|---|--|---|---|------------|----------------------------|
| Long distance | M4 (Free-cut) |  | E3X-NA□ (V) | 700 (2,000) | 1.4-mm dia. (0.03-mm dia.) | E32-T11L | 25 mm |
| | | | E3X-NAG□ | 130 (370) | | | |
| | | | E3X-NA□F | 210 (600) | 1.4-mm dia. (0.5-mm dia.) | | |
| | 3-mm dia. (Free-cut) |  | E3X-NA□ (V) | 700 | 1.4-mm dia. (0.03-mm dia.) | E32-T12L | |
| | | | E3X-NAG□ | 130 | | | |
| | | | E3X-NA□F | 210 | 1.4-mm dia. (0.5-mm dia.) | | |
| | M3 (Free-cut) |  | E3X-NA□ (V) | 200 | 0.9-mm dia. (0.03-mm dia.) | E32-T21L | 10 mm |
| | | | E3X-NAG□ | 40 | | | |
| | | | E3X-NA□F | 60 | 0.9-mm dia. (0.2-mm dia.) | | |
| | 2-mm dia.; small diameter (Free-cut) |  | E3X-NA□ (V) | 200 | 0.9-mm dia. (0.03-mm dia.) | E32-T22L | |
| | | | E3X-NAG□ | 40 | | | |
| | | | E3X-NA□F | 60 | 0.9-mm dia. (0.2-mm dia.) | | |
| M14; with lens; ideal for explosion-proof applications (Free-cut) |  | E3X-NA□ (V) | 14,000 | 10-mm dia. (0.1-mm dia.) | E32-T17L | 25 mm | |
| | | E3X-NA□F | 4,200 | 10-mm dia. (1.5-mm dia.) | | | |
| General-purpose | M4 (Free-cut) |  | E3X-NA□ (V) | 400 (3,000) | 1.0-mm dia. (0.03-mm dia.) | E32-TC200 | 25 mm |
| | | | E3X-NAG□ | 75 (550) | | | |
| | | | E3X-NA□F | 120 (900) | 1.0-mm dia. (0.2-mm dia.) | | |
| | M4 (Free-cut) |  | E3X-NA□ (V) | 280 (2,100) | 1.0-mm dia. (0.03-mm dia.) | E32-T11R | 1 mm |
| | | | E3X-NAG□ | 50 (375) | | | |
| | | | E3X-NA□F | 80 (600) | 1.0-mm dia. (0.2-mm dia.) | | |
| | 3-mm dia. (Free-cut) |  | E3X-NA□ (V) | 280 (2,100) | 1.0-mm dia. (0.03-mm dia.) | E32-T12R | |
| | | | E3X-NAG□ | 50 (375) | | | |
| | | | E3X-NA□F | 80 (600) | 1.0-mm dia. (0.2-mm dia.) | | |
| | M3; possible to mount the reflective side-view conversion attachment E39-F5 (Free-cut) |  | E3X-NA□ (V) | 360 | 1.0-mm dia. (0.03-mm dia.) | E32-TC200A | 25 mm |
| | | | E3X-NAG□ | 65 | | | |
| | | | E3X-NA□F | 100 | 1.0-mm dia. (0.2-mm dia.) | | |
| | M3; for detecting minute sensing objects (Free-cut) |  | E3X-NA□ (V) | 100 | 0.5-mm dia. (0.03-mm dia.) | E32-TC200E | 10 mm |
| | | | E3X-NAG□ | 20 | | | |
| | | | E3X-NA□F | 30 | 0.5-mm dia. (0.1-mm dia.) | | |
| | M3; small diameter (Free-cut) |  | E3X-NA□ (V) | 60 | 0.5-mm dia. (0.03-mm dia.) | E32-T21R | 1 mm |
| | | | E3X-NAG□ | 12 | | | |
| | | | E3X-NA□F | 18 | 1.0-mm dia. (0.1-mm dia.) | | |

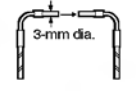
| Application | Features | Appearance | Applicable Amplifier Unit | Sensing distance (mm) (Values in parentheses: when using the E39-F1 Lens Unit) | Standard object (see notes) (min. sensing object: opaque) | Model | Permissible bending radius |
|--|--|--|---------------------------|---|--|---------------------------|----------------------------|
| Thin fiber | 2-mm dia.; for detecting minute sensing objects  |  | E3X-NA□ (V) | 100 | 0.5-mm dia. (0.03-mm dia.) | E32-T22 | 10 mm |
| | | | E3X-NAG□ | 20 | | | |
| | | | E3X-NA□F | 30 | | | |
| | 2-mm dia.; small diameter  |  | E3X-NA□ (V) | 60 | 0.5-mm dia. (0.03-mm dia.) | E32-T22R | 1 mm |
| | | | E3X-NA□F | 18 | 0.5-mm dia. (0.1-mm dia.) | | |
| | 1.2-mm dia.; with sleeve  | 90 mm (40 mm)  M4 screw 1.2-mm dia. (): E32-TC200B4 | E3X-NA□ (V) | 400 | 1.0-mm dia. (0.03-mm dia.) | E32-TC200B E32-TC200B4 | 25 mm |
| | | | E3X-NAG□ | 75 | | | |
| | | | E3X-NA□F | 120 | 1.0-mm dia. (0.2-mm dia.) | | |
| 0.9-mm dia.; with sleeve  | 90 mm (40 mm)  M3 screw 0.9-mm dia. (): E32-TC200F4 | E3X-NA□ (V) | 100 | 0.5-mm dia. (0.03-mm dia.) | E32-TC200F E32-TC200F4 | 10 mm | |
| | | E3X-NAG□ | 20 | | | | |
| | | E3X-NA□F | 30 | 0.5-mm dia. (0.1-mm dia.) | | | |
| Flexible (resists breaking) (R4)  | Ideal for mounting on moving sections (R4) M4 screw  | E3X-NA□ (V) | 360 | 1.0-mm dia. (0.03-mm dia.) | E32-T11 | 4 mm | |
| | | E3X-NAG□ | 65 | | | | |
| | | E3X-NA□F | 100 | 1.0-mm dia. (0.2-mm dia.) | | | |
| | M3 screw  | E3X-NA□ (V) | 100 | 0.5-mm dia. (0.03-mm dia.) | E32-T21 | | |
| | | E3X-NAG□ | 18 | | | | |
| | | E3X-NA□F | 30 | 0.5-mm dia. (0.1-mm dia.) | | | |
| | 1.5-mm dia.  | E3X-NA□ (V) | 100 | 0.5-mm dia. (0.03-mm dia.) | E32-T22B | | |
| | | E3X-NAG□ | 18 | | | | |
| | | E3X-NA□F | 30 | 0.5-mm dia. (0.1-mm dia.) | | | |
| Side-view | Long distance; space-saving  |  | E3X-NA□ (V) | 240 | 1.0-mm dia. (0.03-mm dia.) | E32-T14L | 25 mm |
| | | | E3X-NAG□ | 45 | | | |
| | | | E3X-NA□F | 70 | 1.0-mm dia. (0.2-mm dia.) | | |
| | Space-saving  |  | E3X-NA□ (V) | 110 | 1.0-mm dia. (0.03-mm dia.) | E32-T14LR | 1 mm |
| | | | E3X-NA□F | 33 | 1.0-mm dia. (0.2-mm dia.) | | |
| | Suitable for detecting minute sensing objects  |  | E3X-NA□ (V) | 90 | 0.5-mm dia. (0.03-mm dia.) | E32-T24 | 10 mm |
| | | | E3X-NAG□ | 12 | | | |
| | | | E3X-NA□F | 27 | 0.5-mm dia. (0.3-mm dia.) | | |
| | Suitable for detecting minute sensing objects (small diameter)  |  | E3X-NA□ (V) | 30 | 0.5-mm dia. (0.03-mm dia.) | E32-T24R | 1 mm |
| | | | E3X-NA□F | 9 | 0.5-mm dia. (0.3-mm dia.) | | |
| | Screw-mounting type  |  | E3X-NA□ (V) | 1,800 | 4.0-mm dia. (0.03-mm dia.) | E32-T14 | 25 mm |
| | | | E3X-NAG□ | 330 | | | |
| E3X-NA□F | | | 540 | 4.0-mm dia. (0.2-mm dia.) | | | |

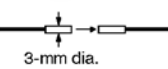
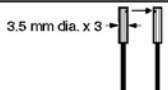
E3X-NA Super Manual Fiber Amplifier

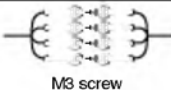
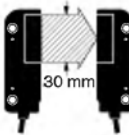
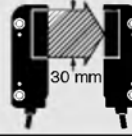
| Application | Features | Appearance | Applicable Amplifier Unit | Sensing distance (mm) (Values in parentheses: when using the E39-F1 Lens Unit) | Standard object (see notes) (min. sensing object: opaque) | Model | Permissible bending radius |
|---|--|--|---------------------------|---|---|----------|----------------------------|
| Chemical-resistant | Teflon-covered *1; withstands chemicals and harsh environments (operating ambient temperature: -30°C to 70°C) (Free-cut) |  5-mm dia. | E3X-NA□(V) | 1,600 | 4.0-mm dia. (0.2-mm dia.) | E32-T12F | 40 mm |
| | | | E3X-NAG□ | 300 | | | |
| | | | E3X-NA□F | 480 | 4.0-mm dia. (0.7-mm dia.) | | |
| | Teflon-covered *1; side-view; withstands chemicals and harsh environments (operating ambient temperature: -30°C to 70°C) (Free-cut) |  5-mm dia. | E3X-NA□(V) | 200 | 3.0-mm dia. (0.2-mm dia.) | E32-T14F | |
| | | | E3X-NAG□ | 37 | | | |
| | | | E3X-NA□F | 60 | 3.0-mm dia. (0.7-mm dia.) | | |
| Teflon *1; withstands chemicals and harsh environments (operating ambient temperature: -40°C to 200°C) |  6-mm dia. | E3X-NA□(V) | 350 | 1.0-mm dia. (0.2-mm dia.) | E32-T81F | 10 mm | |
| | | E3X-NA□F | 100 | 1.0-mm dia. (0.5-mm dia.) | | | |
| Heat-resistant | Resists 200°C; flexible (R10); fiber sheath material: Teflon *1 (operating ambient temperature: -40°C to 200°C) |  M4 screw | E3X-NA□(V) | 180 | 1.0-mm dia. (0.2-mm dia.) | E32-T81R | 10 mm |
| | | | E3X-NA□F | 50 | 1.0-mm dia. (0.5-mm dia.) | | |
| | Resists 150°C *2; fiber sheath material: fluororesin (operating ambient temperature: -40°C to 150°C) (Free-cut) |  M4 screw | E3X-NA□(V) | 400 | 1.5-mm dia. (0.03-mm dia.) | E32-T51 | 35 mm |
| | | | E3X-NA□F | 120 | 1.5-mm dia. (1.0-mm dia.) | | |
| | Resists 300°C *3, with spiral tube; high mechanical strength; fiber sheath material: stainless steel (operating ambient temperature: -40°C to 300°C) |  M4 screw | E3X-NA□(V) | 300 (3,000) | 1.0-mm dia. (0.03-mm dia.) | E32-T61 | 25 mm |
| | | | E3X-NA□F | 90 | 1.0-mm dia. (0.5-mm dia.) | | |
| Side-view; resists 150°C *2; suitable for detecting minute sensing objects; fiber sheath material: fluororesin (operating ambient temperature: -40°C to 150°C) (Free-cut) |  2-mm dia. | E3X-NA□(V) | 130 | 1.0-mm dia. (0.03-mm dia.) | E32-T54 | 35 mm | |
| | | E3X-NA□F | 35 | 1.0-mm dia. (0.3-mm dia.) | | | |
| Resists 200°C *3; L-shaped; fiber sheath material: stainless steel |  3-mm dia. | E3X-NA□(V) | 700 | 1.7-mm dia. (0.03-mm dia.) | E32-T84S | 25 mm | |
| | | E3X-NA□F | 210 | 1.7-mm dia. (0.4-mm dia.) | | | |
| Slot sensor | Suitable for film sheet detection; no optical axis adjustment required; easy to mount (Free-cut) |  | E3X-NA□(V) | 10 | 4.0-mm dia. (0.1-mm dia.) | E32-G14 | 25 mm |
| | | | E3X-NAG□ | 10 | | | |
| | | | E3X-NA□F | 10 | 4.0-mm dia. (1.0-mm dia.) | | |
| Narrow vision field | Suitable for detecting wafers (Free-cut) |  3-mm dia. | E3X-NA□(V) | 1,000 | 1.7-mm dia. (0.5-mm dia.) | E32-T22S | 10 mm |
| | | | E3X-NA□F | 300 | | | |
| | Side-view; suitable for detecting wafers (Free-cut) |  3.5 mm dia. x 3 | E3X-NA□(V) | 700 | 2.0-mm dia. (0.03-mm dia.) | E32-T24S | |
| | | | E3X-NA□F | 210 | 2.0-mm dia. (0.5-mm dia.) | | |

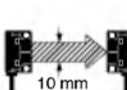
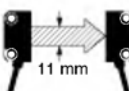
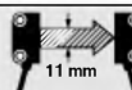
| Application | Features | Appearance | Applicable Amplifier Unit | Sensing distance (mm) (Values in parentheses: when using the E39-F1 Lens Unit) | Standard object (see notes) (min. sensing object: opaque) | Model | Permissible bending radius |
|--|--|---|---------------------------|---|---|-----------|----------------------------|
| Area sensing | Multi-point detection (4-head) |  M3 screw | E3X-NA□ (V) | 300 | 2.0-mm dia. (0.03-mm dia.) | E32-M21 | 25 mm |
| | | | E3X-NA□F | 90 | 2.0-mm dia. (0.3-mm dia.) | | |
| | Detects in a 30-mm area |  30 mm | E3X-NA□ (V) | 920 | (0.5-mm dia.) ^{*4} | E32-T16W | 10 mm |
| | | | E3X-NAG□ | 170 | | | |
| | | | E3X-NA□F | 270 | (4.0-mm dia.) ^{*4} | | |
| | Detects in a 30-mm area |  30 mm | E3X-NA□ (V) | 690 | (0.5-mm dia.) ^{*4} | E32-T16WR | 1 mm |
| | | | E3X-NA□F | 200 | (4.0-mm dia.) ^{*4} | | |
| | Side-view; suitable for applications with limited spatial depth |  11 mm | E3X-NA□ (V) | 520 | (0.3-mm dia.) ^{*4} | E32-T16J | 10 mm |
| | | | E3X-NAG□ | 95 | | | |
| E3X-NA□F | | | 150 | (2.0-mm dia.) ^{*4} | | | |
| Side-view; suitable for applications with limited spatial depth |  11 mm | E3X-NA□ (V) | 390 | (0.3-mm dia.) ^{*4} | E32-T16JR | 1 mm | |
| | | E3X-NA□F | 110 | (2.0-mm dia.) ^{*4} | | | |
| Suitable for detecting over a 10-mm area; long distance |  10 mm | E3X-NA□ (V) | 1,500 | (0.9-mm dia.) ^{*4} | E32-T16 | 25 mm | |
| | | E3X-NAG□ | 275 | | | | |
| | | E3X-NA□F | 450 | (1.5-mm dia.) ^{*4} | | | |
| Stable for detecting minute sensing objects in a wide area; degree of protection: IEC 60529 IP50 |  11 mm | E3X-NA□ (V) | 600 | (0.3-mm dia.) ^{*4} | E32-T16P | 10 mm | |
| | | E3X-NAG□ | 110 | | | | |
| | | E3X-NA□F | 180 | (2.0-mm dia.) ^{*4} | | | |
| Stable for detecting minute sensing objects in a wide area; degree of protection: IEC60529 IP50 |  11 mm | E3X-NA□ (V) | 450 | (0.3-mm dia.) ^{*4} | E32-T16PR | 1 mm | |
| | | E3X-NA□F | 130 | (2.0-mm dia.) ^{*4} | | | |

*1 Teflon is a registered trademark of the Dupont Company and the Mitsui Dupont Chemical Company for their fluoride resin.

*2 For continuous operation, use the products within a temperature range of -40°C to 130°C.

*3 Indicates the heat-resistant temperature at the fiber tip.







*4 These figures are for a sensing distance of 100 mm. (Diameters of sensing objects are ones at a stationary state.)

- Note:**
1. The size of standard sensing object is the same as the fiber core diameter (lens diameter for models with lens).
 2. The values of the minimum sensing object for E3X-NA□ (V) and E3X-NAG□ through-beam models indicate those obtained where the sensing distance and sensitivity are set to optimum values.
 3. The value of the minimum sensing object for E3X-NA□F through-beam models indicates that obtained at the rated sensing distance with the sensitivity set to the optimum value.

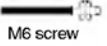
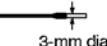
■ Fiber Units with Reflective Sensors

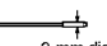

Refer to the end of the following table for notes and precautions.

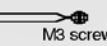
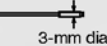





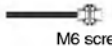
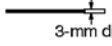
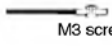
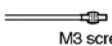
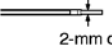
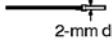
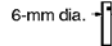

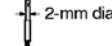
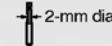
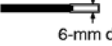

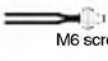
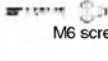
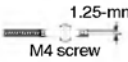
(Free-cut) Indicates models that allow free cutting. Models without this mark do not allow free cutting. : Red light : Green light

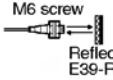
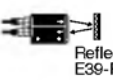
| Application | Features | Appearance | Applicable Amplifier Unit | Sensing distance (mm) *1 | Standard object (see note) (min. sensing object: Gold wire) | Model | Permissible bending radius |
|-----------------|--------------------------------------|--|---------------------------|---|---|------------|----------------------------|
| Long distance | M6 (Free-cut) |  M6 screw | E3X-NA□ (V) | 200 | 250×250 (0.01-mm dia.) | E32-D11L | 25 mm |
| | | | E3X-NAG□ | 35 | 50×50 (0.1-mm dia.) | | |
| | | | E3X-NA□F | 65 | 100×100 (0.015-mm dia.) | | |
| | 3-mm dia.; small diameter (Free-cut) |  3-mm dia. | E3X-NA□ (V) | 120 | 150×150 (0.01-mm dia.) | E32-D12 | |
| | | | E3X-NAG□ | 20 | 25×25 (0.1-mm dia.) | | |
| | | | E3X-NA□F | 40 | 50×50 (0.015-mm dia.) | | |
| M4 | (Free-cut) |  M4 screw | E3X-NA□ (V) | 50 | 100×100 (0.01-mm dia.) | E32-D21L | 10 mm |
| | | | E3X-NAG□ | 10 | 25×25 (0.1-mm dia.) | | |
| | | | E3X-NA□F | 17 | 25×25 (0.015-mm dia.) | | |
| | 3-mm dia.; small diameter (Free-cut) |  3-mm dia. | E3X-NA□ (V) | 50 | 100×100 (0.01-mm dia.) | E32-D22L | |
| | | | E3X-NAG□ | 10 | 25×25 (0.1-mm dia.) | | |
| | | | E3X-NA□F | 17 | 25×25 (0.015-mm dia.) | | |
| General-purpose | M6 (Free-cut) |  M6 screw | E3X-NA□ (V) | 150 | 200×200 (0.01-mm dia.) | E32-DC200 | 25 mm |
| | | | E3X-NAG□ | 25 | 50×50 (0.1-mm dia.) | | |
| | | | E3X-NA□F | 50 | 75×75 (0.015-mm dia.) | | |
| | M6 (Free-cut) |  M6 screw | E3X-NA□ (V) | 90 | 150×150 (0.01-mm dia.) | E32-D11R | 1 mm |
| | | | E3X-NAG□ | 15 | 25×25 (0.1-mm dia.) | | |
| | | | E3X-NA□F | 30 | 50×50 (0.02-mm dia.) | | |
| | 3-mm dia. (Free-cut) |  3-mm dia. | E3X-NA□ (V) | 90 | 150×150 (0.01-mm dia.) | E32-D12R | |
| | | | E3X-NAG□ | 15 | 25×25 (0.1-mm dia.) | | |
| | | | E3X-NA□F | 30 | 50×50 (0.02-mm dia.) | | |
| | M3; small diameter (Free-cut) |  M3 screw | E3X-NA□ (V) | 36 | 50×50 (0.01-mm dia.) | E32-DC200E | 10 mm |
| | | | E3X-NAG□ | 6 | 25×25 (0.1-mm dia.) | | |
| | | | E3X-NA□F | 12 | 25×25 (0.02-mm dia.) | | |
| | M3; small diameter (Free-cut) |  M3 screw | E3X-NA□ (V) | 15 | 25×25 (0.01-mm dia.) | E32-D21R | 1 mm |
| | | | E3X-NA□F | 5 | 25×25 (0.03-mm dia.) | | |
| | 3-mm dia.; small diameter (Free-cut) |  3-mm dia. | E3X-NA□ (V) | 15 | 25×25 (0.01-mm dia.) | E32-D22R | |
| | | | E3X-NA□F | 5 | 25×25 (0.03-mm dia.) | | |

| Application | Features | Appearance | Applicable Amplifier Unit | Sensing distance (mm) *1 | Standard object (see note) (min. sensing object: Gold wire) | Model | Permissible bending radius | |
|-------------|--|--|---------------------------|--------------------------|---|---------------------------|----------------------------|------|
| Thin fiber | 2.5-mm dia.; with sleeve (Free-cut) | <p>90 mm (40 mm) M6 screw 2.5-mm dia. (): E32-DC200B4</p> | E3X-NA□ (V) | 150 | 200×200 (0.01-mm dia.) | E32-DC200B E32-DC200B4 | 25 mm | |
| | | | E3X-NA□ | 25 | 50×50 (0.1-mm dia.) | | | |
| | | | E3X-NA□F | 50 | 75×75 (0.015-mm dia.) | | | |
| | 1.2-mm dia.; with sleeve (Free-cut) | <p>90 mm (40 mm) M3 screw 1.2-mm dia. (): E32-DC200F4</p> | E3X-NA□ (V) | 36 | 50×50 (0.01-mm dia.) | E32-DC200F E32-DC200F4 | 10 mm | |
| | | | E3X-NA□ | 6 | 25×25 (0.1-mm dia.) | | | |
| | | | E3X-NA□F | 12 | 25×25 (0.02-mm dia.) | | | |
| | 0.8-mm dia.; for detecting minute sensing objects (Free-cut) | <p>3-mm dia. 0.8-mm dia.</p> | E3X-NA□ (V) | 10 | 25×25 (0.01-mm dia.) | E32-D33 | 4 mm | |
| | | | E3X-NA□F | 3.3 | 25×25 (0.03-mm dia.) | | | |
| | 0.5-mm dia.; for detecting minute sensing objects | <p>0.5-mm dia. 2-mm dia.</p> | E3X-NA□ | 1.5 | 25×25 (0.01-mm dia.) | E32-D331 | 4 mm | |
| | | | E3X-NA□F | 0.5 | 25×25 (0.05-mm dia.) | | | |
| | Flexible (resists breaking) (R4) | Ideal for mounting on moving sections (R4) (Free-cut) | <p>M6 screw</p> | E3X-NA□ (V) | 90 | 150×150 (0.01-mm dia.) | E32-D11 | 4 mm |
| | | | | E3X-NA□ | 15 | 25×25 (0.1-mm dia.) | | |
| E3X-NA□F | | | | 30 | 50×50 (0.015-mm dia.) | | | |
| (Free-cut) | | <p>M3 screw</p> | E3X-NA□ (V) | 15 | 25×25 (0.01-mm dia.) | E32-D21 | | |
| | | | E3X-NA□F | 15 | 25×25 (0.02-mm dia.) | | | |
| (Free-cut) | | <p>M4 screw</p> | E3X-NA□ (V) | 15 | 25×25 (0.01-mm dia.) | E32-D21B | | |
| | | | E3X-NA□ | 2.4 | 25×25 (0.1-mm dia.) | | | |
| | | | E3X-NA□F | 15 | 25×25 (0.02-mm dia.) | | | |
| (Free-cut) | | <p>1.5-mm dia.</p> | E3X-NA□ (V) | 7 | 25×25 (0.01-mm dia.) | E32-D22B | | |
| | | | E3X-NA□F | 2.3 | 25×25 (0.02-mm dia.) | | | |

E3X-NA Super Manual Fiber Amplifier

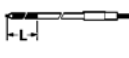
| Application | Features | Appearance | Applicable Amplifier Unit | Sensing distance (mm) *1 | Standard object (see note) (min. sensing object: Gold wire) | Model | Permissible bending radius |
|---|--|--|---------------------------|--------------------------|---|-----------|----------------------------|
| Coaxial | M6 coaxial; high-precision positioning (Free-cut) |  M6 screw | E3X-NA□ (V) | 150 | 200×200 (0.01-mm dia.) | E32-CC200 | 25 mm |
| | | | E3X-NAG□ | 25 | 50×50 (0.1-mm dia.) | | |
| | | | E3X-NA□F | 50 | 75×75 (0.015-mm dia.) | | |
| | 3-mm dia. coaxial; small diameter; high-precision positioning (Free-cut) |  3-mm dia. | E3X-NA□ (V) | 80 | 100×100 (0.01-mm dia.) | E32-D32L | |
| | | | E3X-NAG□ | 12 | 25×25 (0.1-mm dia.) | | |
| | | | E3X-NA□F | 25 | 50×50 (0.02-mm dia.) | | |
| | M3 coaxial; high-precision positioning; possible to mount small-spot lens (E39-F3A-5/F3B/F3C) (Free-cut) |  M3 screw | E3X-NA□ (V) | 40 | 50×50 (0.01-mm dia.) | E32-C31 | |
| | | | E3X-NAG□ | 16 | 25×25 (0.1-mm dia.) | | |
| | | | E3X-NA□F | 13 | 25×25 (0.02-mm dia.) | | |
| | M3 coaxial; high-precision positioning; possible to mount small-spot lens (E39-F3A-5/F3B/F3C) |  M3 screw | E3X-NA□ (V) | 15 | 25×25 (0.01-mm dia.) | E32-C41 | |
| | | | E3X-NA□F | 15 | 25×25 (0.02-mm dia.) | | |
| | 2-mm dia. coaxial; high-precision positioning; possible to mount small-spot (0.1 to 0.6 dia.) lens (E39-F3A) |  2-mm dia. | E3X-NA□ (V) | 15 | 25×25 (0.01-mm dia.) | E32-C42 | |
| E3X-NA□F | | | 15 | 25×25 (0.02-mm dia.) | | | |
| 2-mm dia. coaxial; high-precision positioning; possible to mount small-spot (0.5 to 1 dia.) lens (E39-F3A) (Free-cut) |  2-mm dia. | E3X-NA□ (V) | 40 | 50×50 (0.01-mm dia.) | E32-D32 | | |
| | | E3X-NAG□ | 16 | 25×25 (0.1-mm dia.) | | | |
| | | E3X-NA□F | 13 | 25×25 (0.02-mm dia.) | | | |
| Side-view | 6-mm dia.; long distance (Free-cut) |  6-mm dia. | E3X-NA□ (V) | 40 | 50×50 (0.03-mm dia.) | E32-D14L | 25 mm |
| | | | E3X-NAG□ | 10 | 25×25 (0.3-mm dia.) | | |
| | | | E3X-NA□F | 13 | 25×25 (0.03-mm dia.) | | |
| | 6-mm dia. (Free-cut) |  6-mm dia. | E3X-NA□ (V) | 16 | 25×25 (0.03-mm dia.) | E32-D14LR | 1 mm |
| | | | E3X-NA□F | 15 | | | |
| | 2-mm dia.; small diameter space-saving (Free-cut) |  2-mm dia. | E3X-NA□ (V) | 15 | 25×25 (0.03-mm dia.) | E32-D24 | 10 mm |
| | | | E3X-NAG□ | 2.4 | 25×25 (0.3-mm dia.) | | |
| | | | E3X-NA□F | 15 | 25×25 (0.03-mm dia.) | | |
| 2-mm dia.; small diameter space-saving (Free-cut) |  2-mm dia. | E3X-NA□ (V) | 7 | 25×25 (0.03-mm dia.) | E32-D24R | 1 mm | |
| | | E3X-NA□F | 12.3 | | | | |
| Chemical-resistant | Teflon-covered *3; withstands chemicals and harsh environments (operating ambient temperature: -30°C to 70°C) (Free-cut) |  6-mm dia. | E3X-NA□ (V) | 50 | 100×100 (0.03-mm dia.) | E32-D12F | 40 mm |
| | | | E3X-NAG□ | 18 | 25×25 (0.3-mm dia.) | | |
| | | | E3X-NA□F | 16 | 25×25 (0.03-mm dia.) | | |

| Application | Features | Appearance | Applicable Amplifier Unit | Sensing distance (mm) *1 | Standard object (see note) (min. sensing object: Gold wire) | Model | Permissible bending radius |
|-----------------------|--|---|---------------------------|--------------------------|---|------------------------------|----------------------------|
| Heat-resistant | Resists 150°C *2; fiber sheath material: fluoro-resin (operating ambient temperature: -40°C to 150°C) (Free-cut) |  M6 screw | E3X-NA□ (V) | 120 | 150×150 (0.03-mm dia.) | E32-D51 | 35 mm |
| | | | E3X-NA□F | 40 | 50×50 (0.03-mm dia.) | | |
| | Resists 300°C *4; fiber sheath material: stainless steel (operating ambient temperature: -40°C to 300°C) |  M6 screw | E3X-NA□ (V) | 45 | 100×100 (0.03-mm dia.) | E32-D61 | 25 mm |
| | | | E3X-NA□F | 15 | 25×25 (0.03-mm dia.) | | |
| | Resists 400°C *4; fiber sheath material: stainless steel (operating ambient temperature: -40°C to 400°C) |  1.25-mm dia. M4 screw | E3X-NA□ (V) | 30 | 50×50 (0.03-mm dia.) | E32-D73 | 25 mm |
| | | | E3X-NA□F | 10 | 25×25 (0.03-mm dia.) | | |
| Area sensing | Side-view; detection over wide areas (Free-cut) |  | E3X-NA□ (V) | 75 | 100×100 (0.03-mm dia.) | E32-D36P1 | 25 mm |
| | | | E3X-NA□F | 25 | 50×50 (0.03-mm dia.) | | |
| Retro-reflective | Transparent object detection (Free-cut) |  M6 screw Reflector E39-R3 | E3X-NA□ (V) | 10 to 250 | 35-mm dia. (0.3-mm dia.) | E32-R21 +E39-R3 (Attachment) | 10 mm |
| | | | E3X-NA□F | 10 to 250 | 35-mm dia. (0.5-mm dia.) | | |
| | Transparent object detection (operating ambient temperature: -25°C to 55°C); degree of protection: IEC 60529 IP66 (Free-cut) |  Reflector E39-R1 | E3X-NA□ (V) | 150 to 1,500 | 35-mm dia. (0.6-mm dia.) | E32-R16 +E39-R1 (Attachment) | 25 mm |
| | | | E3X-NA□F | 150 to 1,000 | 35-mm dia. (4.0-mm dia.) | | |
| Limited reflective | Suitable for positioning crystal glass (Free-cut) |  | E3X-NA□ (V) | 4 to 12 | --- | E32-L56E1 E32-L56E2 | 35 mm |
| | | | E3X-NA□F | 4 to 12 | --- | | |
| | Detects wafers and small differences in height; (operating ambient temperature: -40°C to 105°C); degree of protection: IEC 60529 IP50 (Free-cut) |  | E3X-NA□ (V) | 4±2 | 25×25 (0.015-mm dia.) | E32-L24L | 10 mm |
| | | | E3X-NA□F | 4±2 | 25×25 (0.03-mm dia.) | | |
| | |  | E3X-NA□ (V) | 7.2±1.8 | 25×25 (0.015-mm dia.) | E32-L25L | 10 mm |
| | | | E3X-NA□F | 7.2±1.8 | 25×25 (0.03-mm dia.) | | |
| | Detects wafers and small differences in height; degree of protection: IEC 60529 IP50 (Free-cut) |  | E3X-NA□ (V) | 3.3 | 25×25 (0.015-mm dia.) | E32-L25 | 25 mm |
| | | | E3X-NA□F | 3.3 | 25×25 (0.03-mm dia.) | | |
| | |  | E3X-NA□ (V) | 3.3 | 25×25 (0.015-mm dia.) | E32-L25A | 25 mm |
| | | | E3X-NA□F | 3.3 | 25×25 (0.03-mm dia.) | | |
| Fluid-level detection | Fluid contact type: unbendable section L 150 mm, 350 mm (two types) |  L 150 | E3X-NA□ (V) | --- | --- | E32-D82F1 E32-D82F2 | 40 mm |
| | | | E3X-NA□F | --- | --- | | |
| | Tube-mounting type (Free-cut) |  | E3X-NA□ (V) | --- | --- | E32-L25T | 10 mm |
| | | | E3X-NA□F | --- | --- | | |

*1 Sensing distance indicates values for white paper.

*2 For continuous operation, use the products within a temperature range of -40°C to 130°C.

*3 Teflon is a registered trademark of the Dupont Company and the Mitsui Dupont Chemical Company for their fluoride resin.

*4 Indicates the heat-resistant temperature at the fiber tip.

Note The values of the minimum sensing object indicate those obtained at a distance where the smallest object can be sensed with the Reflective Fiber Unit.

Operation

Output Circuits

| Output | Model | Mode selector | Timing chart | State of output transistor | Output circuit |
|--------|---|-----------------|--------------|----------------------------|--|
| NPN | E3X-NA11 E3X-NA6 E3X-NAG11 E3X-NA11F E3X-NA11V E3X-NA14V | LIGHT ON (L/ON) | | Light ON | <p>M8 Connector Pin Arrangement</p> <p>Note Pin 2 is not used.</p> |
| | | DARK ON (D/ON) | | Dark ON | <p>M8 Connector Pin Arrangement</p> <p>Note Pin 2 is not used.</p> |
| PNP | E3X-NA41 E3X-NA8 E3X-NAG41 E3X-NA41F E3X-NA41V E3X-NA44V | LIGHT ON (L/ON) | | Light ON | <p>M8 Connector Pin Arrangement</p> <p>Note Pin 2 is not used.</p> |
| | | DARK ON (D/ON) | | Dark ON | <p>M8 Connector Pin Arrangement</p> <p>Note Pin 2 is not used.</p> |

Connectors (Sensor I/O Connectors)

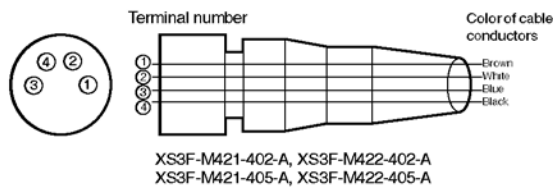

| Classification | Color of cable conductors | Connection pin number | Application |
|----------------|---------------------------|-----------------------|--------------------|
| DC | Brown | 1 | Power supply (+V) |
| | White | 2 | --- |
| | Blue | 3 | Power supply (0 V) |
| | Black | 4 | Output |

Note Pin 2 is not used.

Engineering Data (Typical)

Parallel Operating Range

At max. sensitivity. (Use for optical axis adjustment at installation.)

E32-TC200

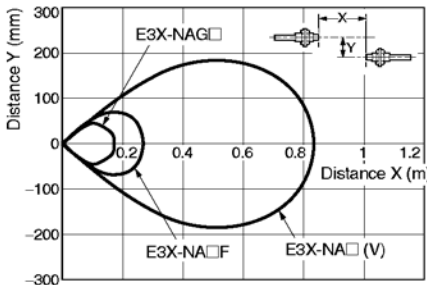

E32-T11L/T12L

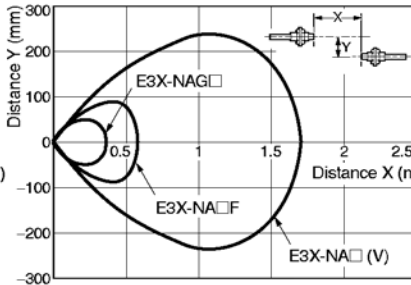

E32-T11R

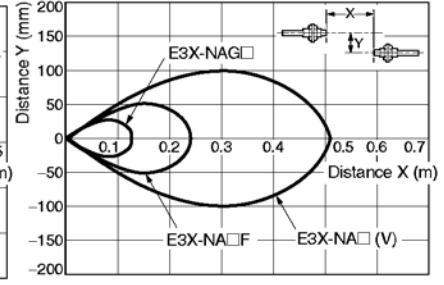

E32-T11

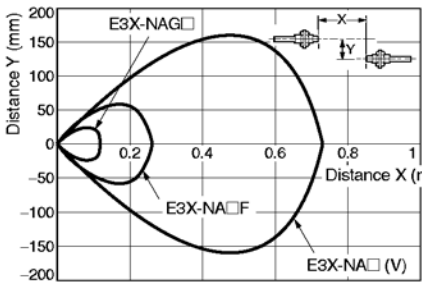

E32-TC200E

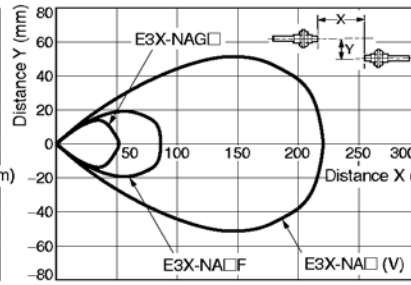

E32-T24S

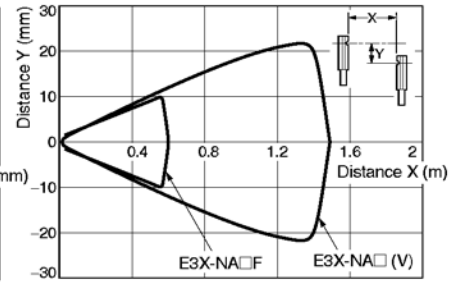

Operating Range

With standard sensing object at max. sensitivity. (Use for the positioning of the object and Sensor.)

E32-DC200

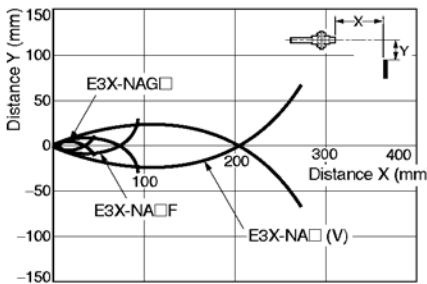

E32-D11L

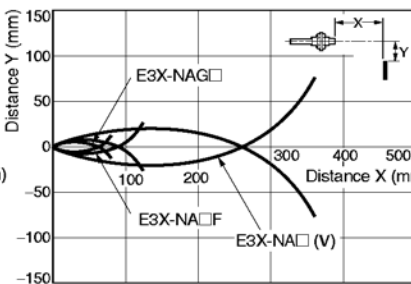

E32-D11R/D12R

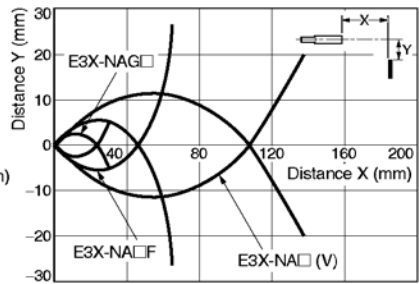

E32-DC200E

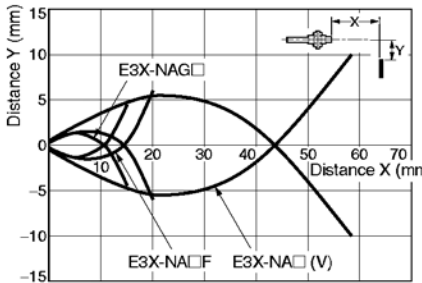

E32-D33

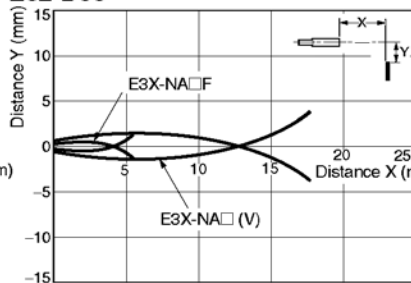

E32-L25L

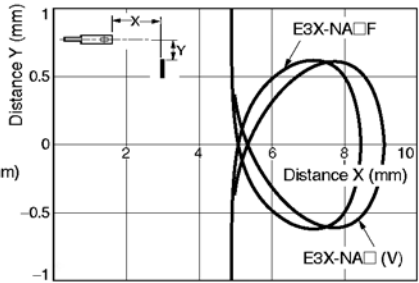

Number of Turns of Sensitivity Adjuster vs. Sensing Distance

E32-T11L

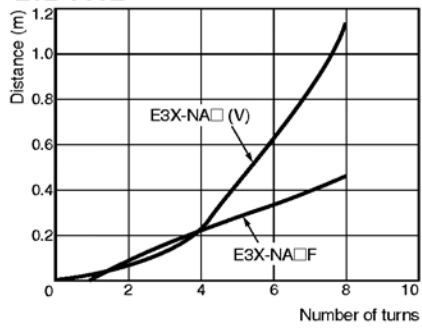

E32-D11L

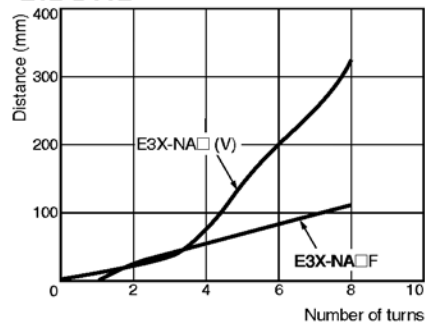

Sensing Distance vs. Hysteresis

E32-T11L

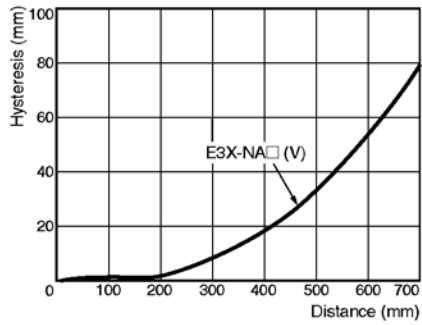

E32-D11L

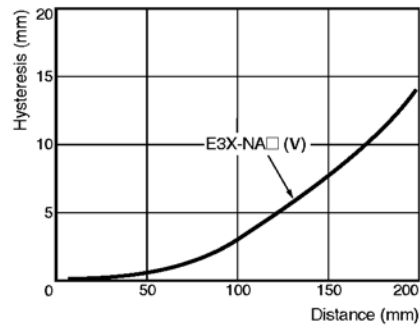

Application

■ Wiring Precautions

Read the following before using the Amplifier Unit and Sensor to ensure safety.

Power Supply Voltage

Do not impose any voltage exceeding the rated voltage on the E3X-NA. Do not impose AC power (100 VAC) on models that operate with DC. In both cases, the E3X-NA may rupture or burn.

Load Short-circuits

Do not short-circuit the load connected to the E3X-NA, otherwise the E3X-NA may rupture or burn.

Polarity

When supplying power to the E3X-NA, make sure that the polarity of the power is correct, otherwise the E3X-NA may rupture or burn.

No-load Operation

A load must be connected to the E3X-NA during operation, otherwise internal elements may rupture or burn. Always wire through a load.

Operating Environment

- Do not use the Amplifier Unit or Sensor in places with flammable or explosive gas.
- Do not use the Amplifier Unit or Sensor underwater.
- Do not disassemble, repair, or modify the Amplifier Unit or Sensor.

■ Amplifier Units

Nomenclature

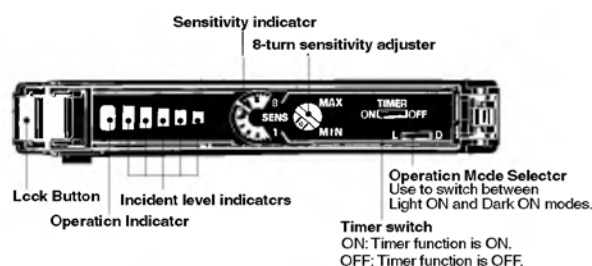

Installation

Turning Power ON

The Sensor is ready to operate within 100 ms after the power supply is turned ON. If the Sensor and load are connected to power supplies separately, be sure to turn ON the power supply to the Sensor first.

Turning Power OFF

Pulses may be output when the power is turned OFF. Always turn OFF the power to the load or the load line first.

Power Supply Type

A full or half-wave rectifying power supply without a smoothing circuit cannot be used.

Communications Hole

The hole on the side of the Amplifier Unit is a communications hole for preventing mutual interference when Amplifier Units are mounted side-by-side. The E3X-MC11 Mobile Console (sold separately) cannot be used.

If an excessive amount of light is received via the Sensor, the mutual interference prevention function may not work. In this case, make the appropriate adjustments using the sensitivity adjuster.

The mutual interference prevention function will not operate when the E3X-NA is used side-by-side with E3X-DA-N models.

Wiring

Cable

The cable can be extended, provided that the extension wire applied is at least 0.3 mm² thick and the total distance no more than 100 m.

Do not pull the cable with a force exceeding 30N.

Separation from Power or High-tension Lines

Do not wire power lines or high-tension lines alongside the lines of the Amplifier Unit in the same conduit, otherwise the Amplifier Unit may be damaged or malfunction due to induction. Be sure to wire the lines of the Amplifier Unit separated as far as possible from power lines or high-tension lines or laid in an exclusive, shielded conduit.

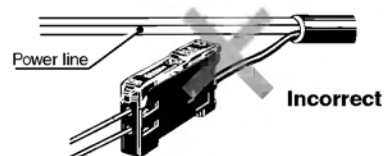

Power Supply

If a standard switching regulator is used as a power supply, the frame ground (FG) terminal and the ground (G) terminal must be grounded, otherwise faulty operation may result from the switching noise of the power supply.

M8 Metal Connectors (Water-resistant Models)

Turn OFF the power before inserting or removing the connector.

Hold the connector cover when inserting or removing the connector.

Tighten the fixing screws by hand. Using tools such as pliers may cause damage.

The applicable tightening torque range is 0.3 to 0.4 N·m. If tightening is insufficient, the enclosure rating may not be maintained, and vibrations may cause the connector to come loose.

Mounting

Joining Amplifier Units

1. Mount the Amplifier Units one at a time onto the DIN track.

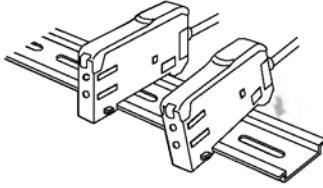

2. Slide the Amplifier Units together, line up the clips, and press the Amplifier Units together until they click into place.

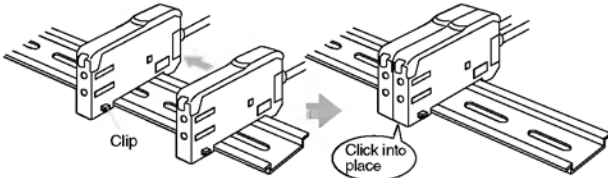

Separating Amplifier Units

Slide Amplifier Units away from each other, and remove from the DIN track one at a time. (Do not attempt to remove Amplifier Units from the DIN track without separating them first.)

- Note:**
1. The specifications for ambient temperature will vary according to the number of Amplifier Units used together. For details, refer to *Ratings/Characteristics*.
 2. Always turn OFF the power supply before joining or separating Amplifier Units.

Mounting

1. Mount the front part on the mounting bracket (ordered separately) or a DIN track.
2. Press the back part onto the mounting bracket or the DIN track.

Note Do not mount the back of the Amplifier Unit onto the mounting bracket or the DIN track first, otherwise the mounting strength of the Amplifier Unit may be reduced. Always mount the front of the Amplifier Unit first.

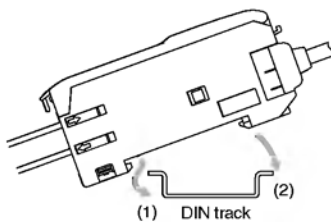

Dismounting

By pressing the Amplifier Unit in direction (3) and lifting the fiber insertion part in direction (4) as shown in the following diagram, the Amplifier Unit can be dismounted with ease.

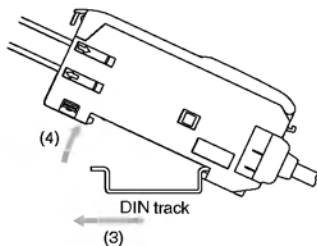

When side-mounting using a mounting bracket, secure the mounting bracket to the Amplifier Unit and then mount using M3 screws. Use plain washers of diameter 6 mm or less when mounting.

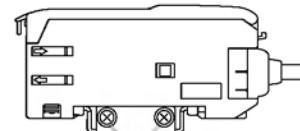

Plain washers
(6-mm dia. max.)

Adjustment

Indicators

In addition to an operation indicator (orange), the E3X-NA also has incident level indicators (4 green and 1 red). Use these indicators for optical axis adjustments and maintenance.

| Status of indicators (in L/ON mode) | Operation indicator (in L/ON mode) | Incident level |
|---|------------------------------------|---|
| Operation indicator Incident level indicators | Not lit | Approx. 80% max. of operating level |
| | Not lit | Approx. 80% to 90% of operating level |
| | Not lit or lit | Approx. 90% to 110% of operating level |
| | Lit | Approx. 110% to 120% of operating level |
| | Lit | Approx. 120% min. of operating level |

Note The rightmost indicator will be lit even if the incident level is 0.

Operating Environment

Ambient Conditions

If dust or dirt adhere to the hole for optical communications, it may prevent normal communications. Be sure to remove any dust or dirt before using the Units.

Miscellaneous

Ratings and Specifications

The ratings and performance specifications for items such as the minimum sensing object and characteristics are based on products taken at random from certain production lots. Use this data as reference only.

Protective Cover

Be sure to mount the Protective Cover before use.

Fiber Unit

Mounting

Tightening Force

The tightening force applied to the Fiber Unit should be as follows:

Screw-mounting Model

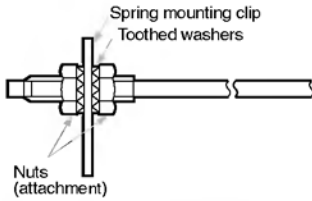

Cylindrical Model

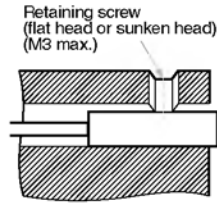

| Fiber Units | Clamping torque |
|--|--|
| M3/M4 screw | 0.78 N·m max. |
| M6 screw/ 6-mm dia. cylinder | 0.98 N·m max. |
| 1.5-mm dia. cylinder | 0.2 N·m max. |
| 2-mm dia./3-mm dia. cylinder | 0.29 N·m max. |
| E32-T12F 5-mm dia. Teflon model | 0.78 N·m max. |
| E32-D12F 6-mm dia. Teflon model | |
| E32-T16 | 0.49 N·m max. |
| E32-R21 | 0.59 N·m max. |
| E32-M21 | Up to 5 mm to the tip: 0.49 N·m max. More than 5 mm from the tip: 0.78 N·m max. |
| E32-L25A | 0.78 N·m max. |
| E32-T16P E32-T16PR E32-T24S E32-L24L E32-L25L E32-T16J E32-T16JR | 0.29 N·m max. |
| E32-T16W E32-T16WR | 0.3 N·m max. |

Use a proper-sized wrench.



Fiber Connection and Disconnection

The E3X Amplifier Unit has a lock button. Connect or disconnect the fibers to or from the E3X Amplifier Unit using the following procedures:

1. Connection

Open the protective cover, insert the fibers according to the fiber insertion marks on the side of the Amplifier Unit, and lower the lock button.

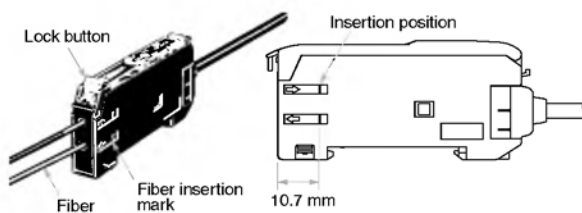

2. Disconnection

Remove the protective cover and raise the lock button to pull out the fiber.

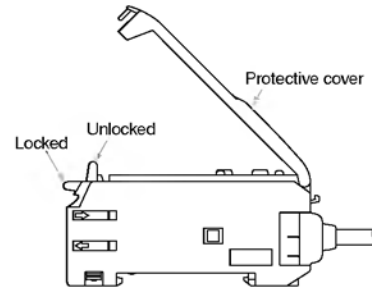

Note To maintain the fiber properties, confirm that the lock is released before removing the fiber.

3. Precautions for Fiber Connection/Disconnection

Be sure to lock or unlock the lock button within an ambient temperature range between -10°C and 40°C .

Cutting Fiber

Insert a fiber into the Fiber Cutter and determine the length of the fiber to be cut.

Press down the Fiber Cutter in a single stroke to cut the fiber.

The cutting holes cannot be used twice. If the same hole is used twice, the cutting face of the fiber will be rough and the sensing distance will be reduced. Always use an unused hole.

Cut a thin fiber as follows:

1. An attachment is temporarily fitted to a thin fiber before shipment.

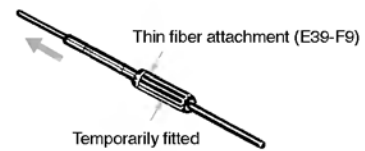

2. Secure the attachment after adjusting the position of it in the direction indicated by the arrow.



3. Insert the fiber to be cut into the E39-F4.

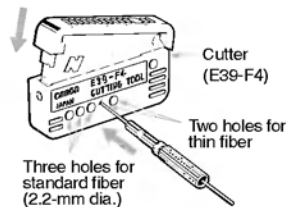

4. Finished state (proper cutting state)

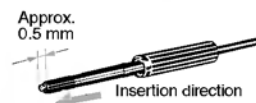

Note Insert the fiber in the direction indicated by the arrow.

Connection

Do not pull or press the Fiber Units. The Fiber Units have a withstand force of 9.8 N or 29.4 N maximum (pay utmost attention because the fibers are thin).

Do not bend the Fiber Unit beyond the permissible bending radius given under *Specifications: Amplifier Units* on page 3.

Do not bend the edge of the Fiber Units (excluding the E32-T□R and E32-D□R).

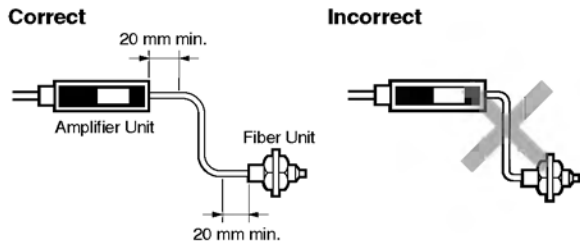

Do not apply excess force on the Fiber Units.

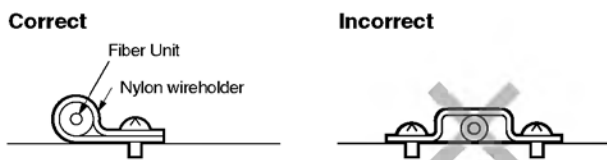

The Fiber Head could be broken by excessive vibration. To prevent this, the following is effective:

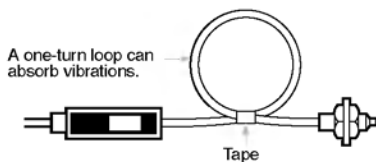

Bending Radius

E39-F11 Sleeve Bender

The bending radius of the stainless steel tube should be as large as possible. The smaller the bending radius becomes, the shorter the sensing distance will be.

Insert the tip of the stainless steel tube to the Sleeve Bender and bend the stainless steel tube slowly along the curve of the Sleeve Bender (refer to the figure).

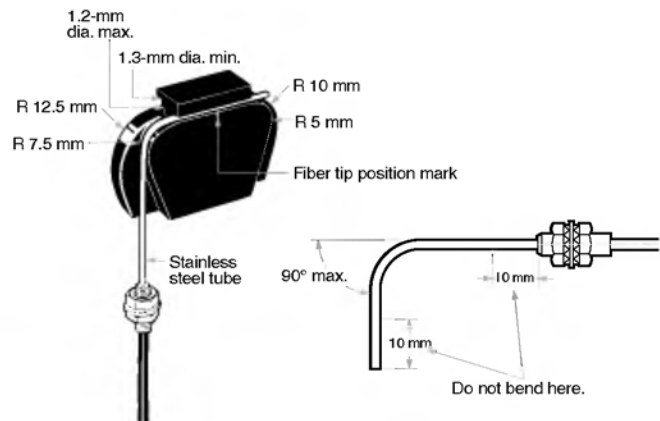

Amplifier Units with Connectors

Mounting

Mounting Connectors

1. Insert the Master or Slave Connector into the Amplifier Unit until it clicks into place.

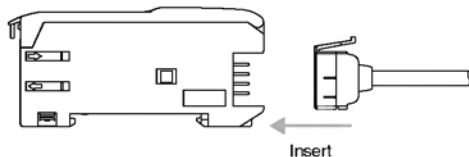

2. Join Amplifier Units together as required after all the Master and Slave Connectors have been inserted.
3. Attach the stickers (provided as accessories) to the sides of Master and Slave Connectors that are not connected to other Connectors.

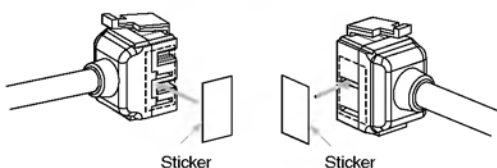

Note Attach the stickers to the sides with grooves.

Removing Connectors

1. Slide the slave Amplifier Unit for which the Connector is to be removed away from the rest of the group.
2. After the Amplifier Unit has been separated, press down on the lever on the Connector and remove it. (Do not attempt to remove Connectors without separating them from other Amplifier Units first.)

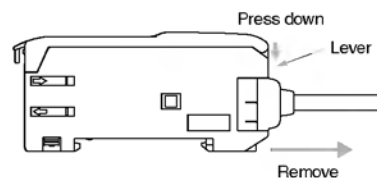

Mounting End Plate (PFP-M)

Depending on how it is mounted, an Amplifier Unit may move during operation. In this case, use an End Plate.

Before mounting an End Plate, remove the clip from the master Amplifier Unit using a nipper or similar tool.

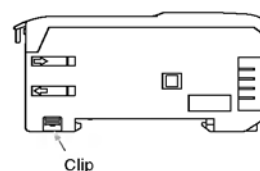

The clip can also be removed using the following mechanism, which is incorporated in the construction of the section underneath the clip.

1. Insert the clip to be removed into the slit underneath the clip on another Amplifier Unit.

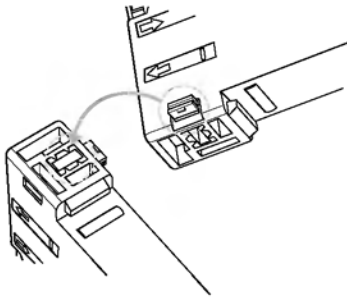

2. Remove the clip by rotating the Amplifier Unit.

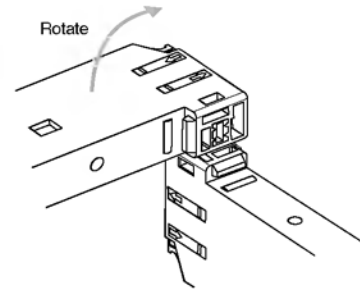

Pull Strengths for Connectors (Including Cables)

E3X-CN11: 30 N max.
E3X-CN12: 12 N max.

■ Reflector

Use of E39-R3 Reflector

Use detergent, etc., to remove any dust or oil from the surfaces where tape is applied. Adhesive tape will not be attached properly if oil or dust remains on the surface.

The E39-R3 cannot be used in places where it is exposed to oil or chemicals.

E39-F32 Protective Spiral Tubes

Insert a fiber to the Protective Spiral Tube from the head connector side (screwed) of the tube.

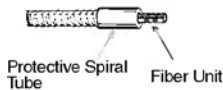

Push the fiber into the Protective Spiral Tube. The tube should be straight so that the fiber is not twisted when inserted. Then turn the end cap of the spiral tube.

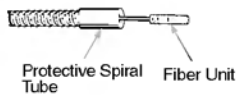

Secure the Protective Spiral Tube on a suitable place with the attached nut.

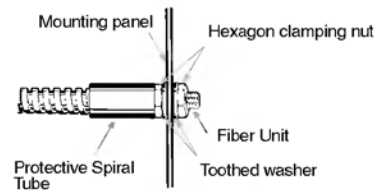

Use the attached saddle to secure the end cap of the Protective Spiral Tube. To secure the Protective Spiral Tube at a position other than the end cap, apply tape to the tube so that the portion becomes thicker in diameter.

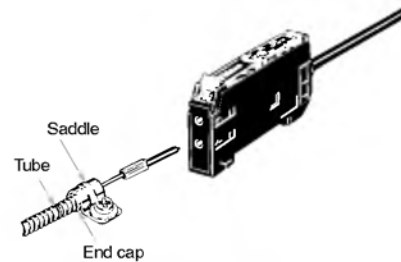

E39-F10 Fiber Connector

Mount the Fiber Connector as shown in the following illustrations.

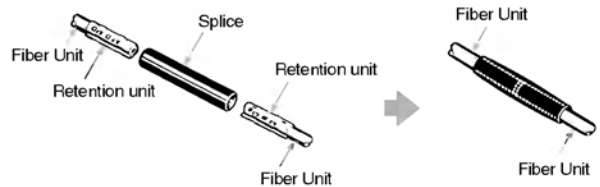

The Fiber Units should be as close as possible when they are connected.

Sensing distance will be reduced by approximately 25% when fibers are connected.

Only 2.2-mm-dia. fibers can be connected.

Dimensions

Note All units are in millimeters unless otherwise indicated.

Amplifier Units

Amplifier Units with Cables (with Mounting Bracket Attached)

E3X-NA11
E3X-NA11F
E3X-NA41
E3X-NA41F
E3X-NAG11
E3X-NAG41

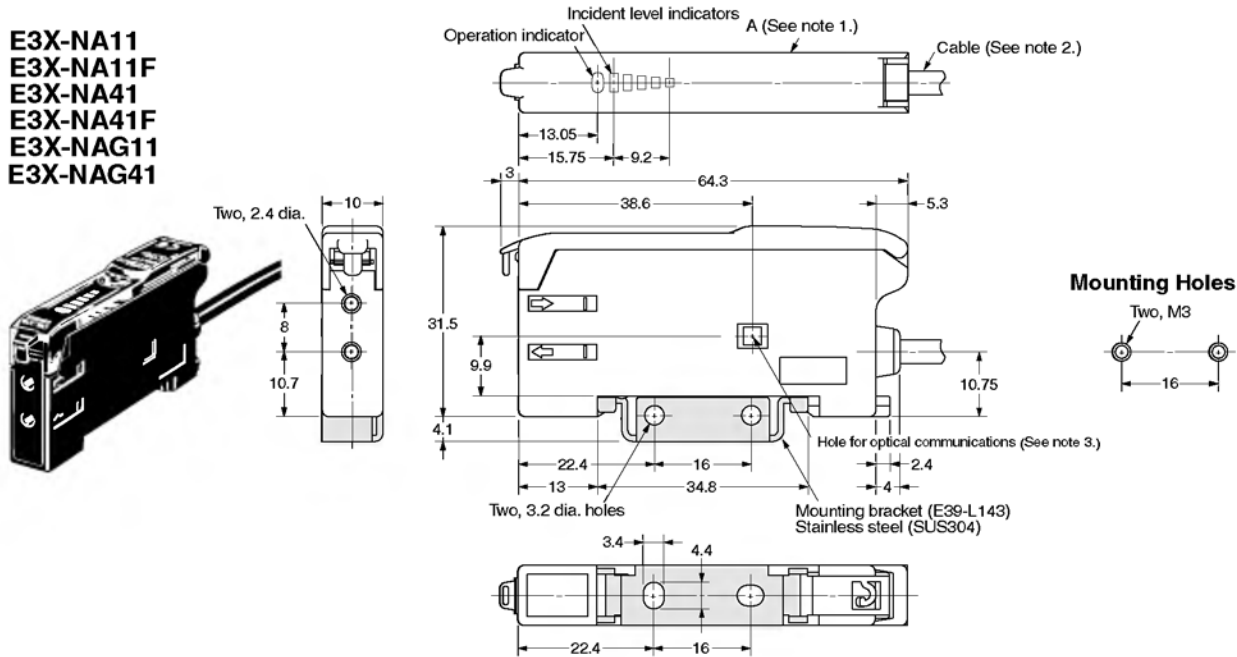

Note: 1. The mounting bracket can also be used on side A.
2. With these models, a 4-dia., 3-conductor, vinyl-insulated round cable (conductor cross-sectional area: 0.45 mm²; insulation diameter: 1.1 mm) is used.

3. The hole for optical communications is for preventing mutual interference. There is no hole for E3X-NA□F models.

Amplifier Units with Cables, Water-resistant Models (with Mounting Bracket Attached)

E3X-NA11V
E3X-NA41V

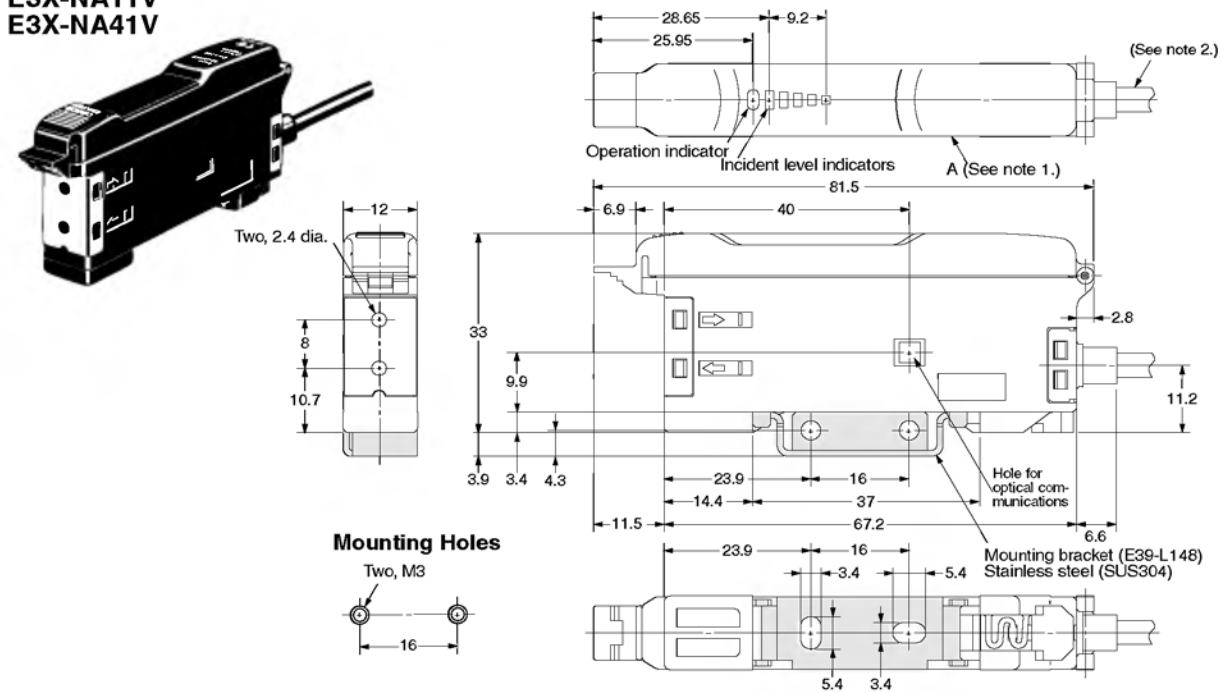

Note: 1. The mounting bracket can also be used on side A.
2. With these models, a 4-dia., 3-conductor, vinyl-insulated round cable (conductor cross-sectional area: 0.45 mm²; insulation diameter: 1.1 mm) is used. Standard length: 2 m.

Amplifier Units with Connectors

E3X-NA6
E3X-NA8

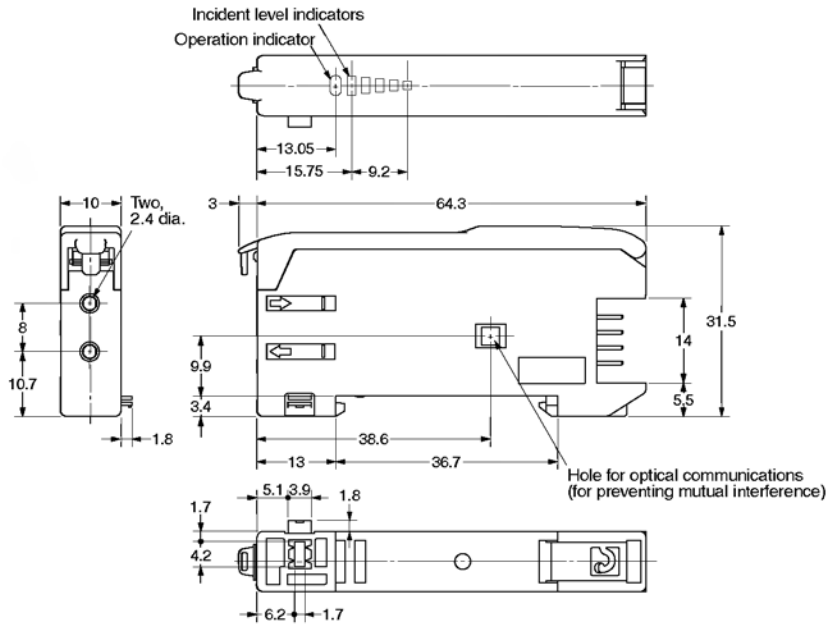

Dimensions with Master Connector Connected

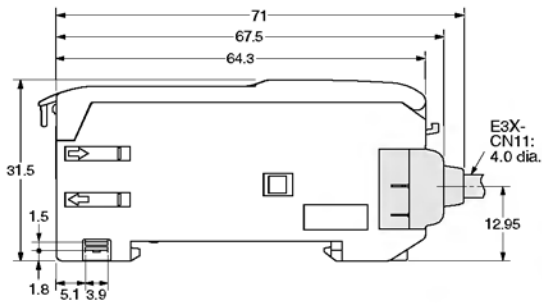

Dimensions with Slave Connector Connected

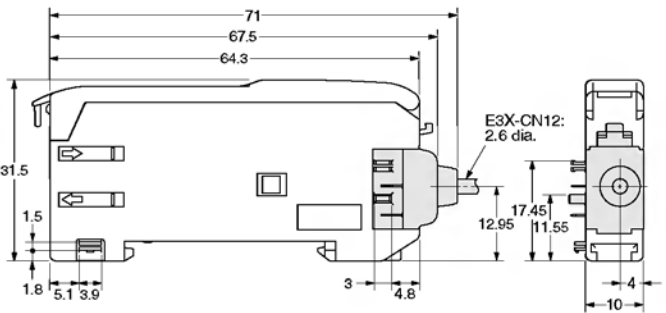

Amplifier Units with Connectors, Water-resistant Models (with Mounting Bracket Attached)

E3X-NA14V
E3X-NA44V

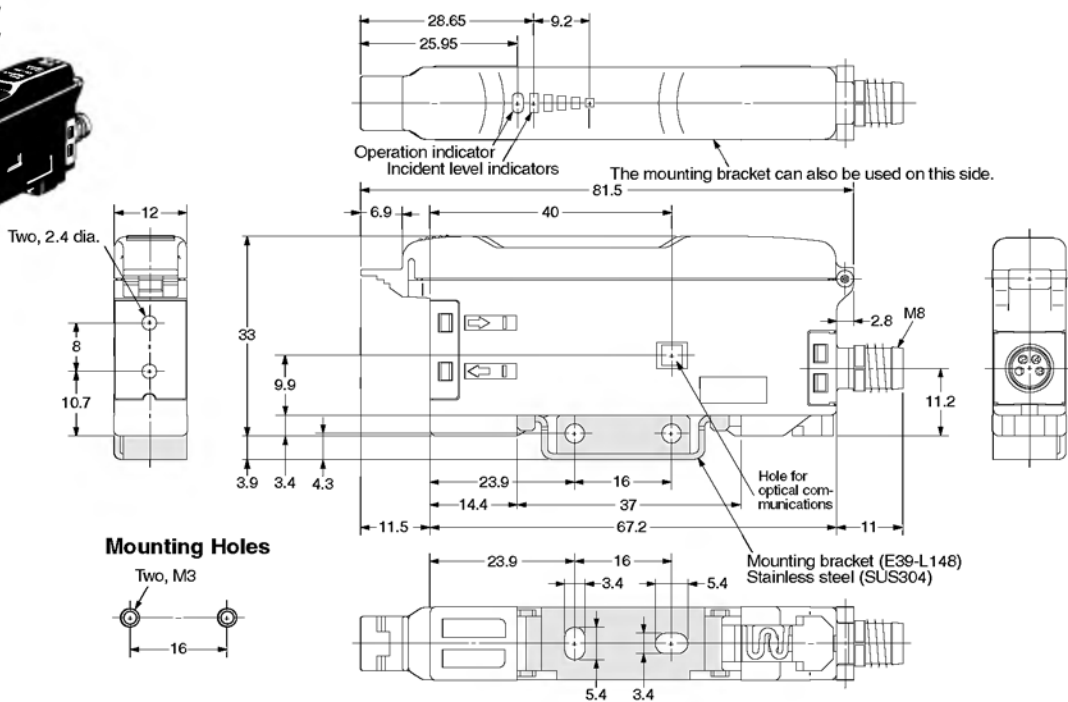

■ Amplifier Unit Connectors

Master Connectors E3X-CN11

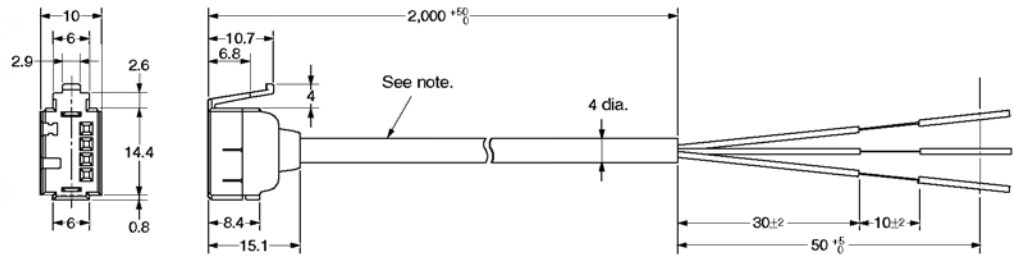

Note: A 4-dia., 3-conductor, vinyl-insulated round cable (conductor cross-sectional area: 0.2 mm²; insulation diameter: 1.1 mm) is used.

Slave Connectors E3X-CN12

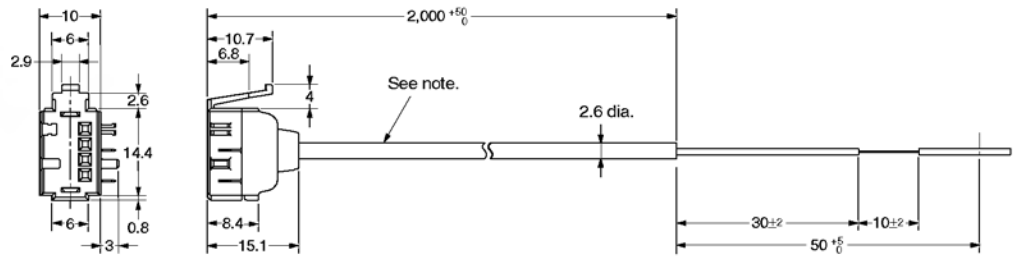

Note: A 2.6-dia., single-conductor, vinyl-insulated round cable (conductor cross-sectional area: 0.2 mm²; insulation diameter: 1.1 mm) is used.

■ Sensor I/O Connectors

Straight Connector (at One End of Cable)

XS3F-M421-402-A (L=2 m)

XS3F-M421-405-A (L=5 m)

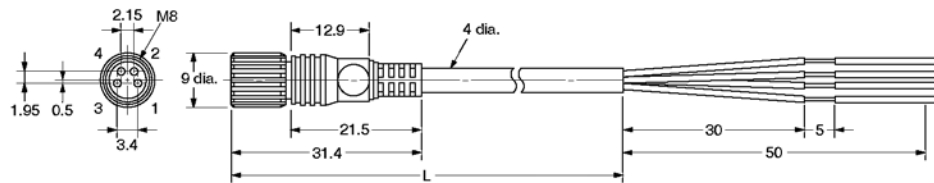

L-shaped Connector (at One End of Cable)

XS3F-M422-402-A (L=2 m)

XS3F-M422-405-A (L=5 m)

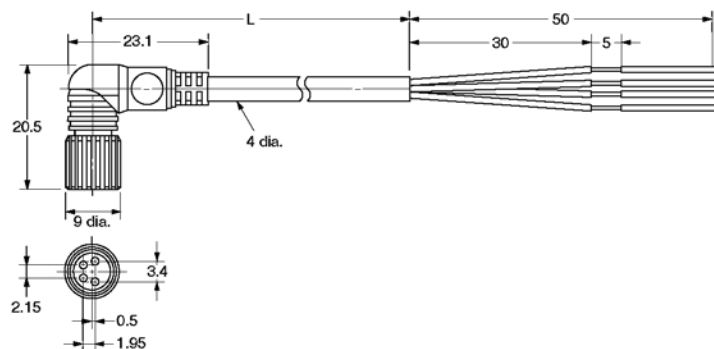

■ Accessories (Order Separately)

Mounting Bracket for E3X-NA□, E3X-NA□F, and E3X-NAG□ Models

E39-L143

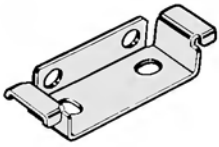

Material: Stainless steel (SUS 304)

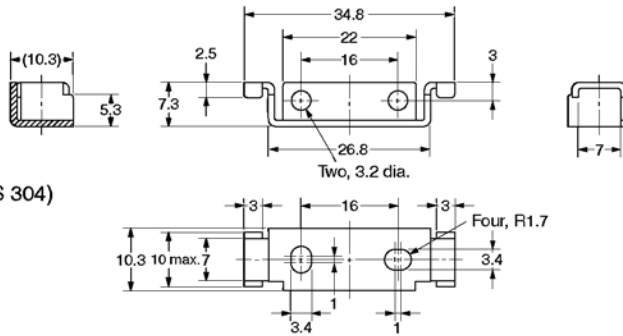

Mounting Holes

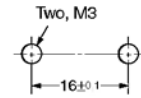

Mounting Bracket for E3X-NA□V Models

E39-L148

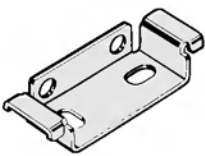

Material: Stainless steel (SUS 304)

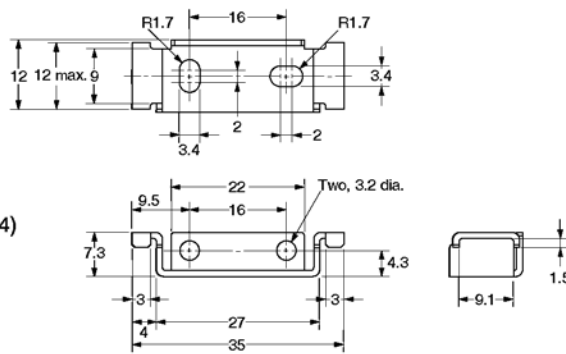

Mounting Holes

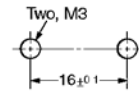

End Plate

PFP-M

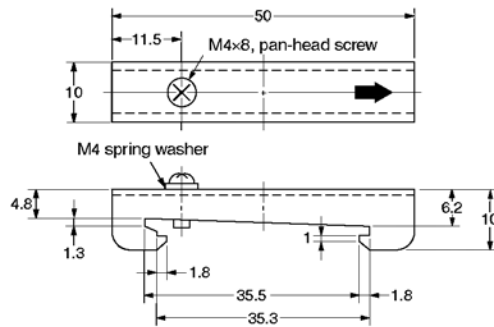
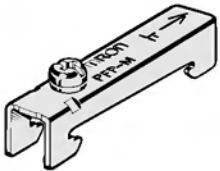

ALL DIMENSIONS SHOWN ARE IN MILLIMETERS.

To convert millimeters into inches, multiply by 0.03937. To convert grams into ounces, multiply by 0.03527.

Cat. No. E318-E1-2

In the interest of product improvement, specifications are subject to change without notice.

OMRON Corporation

Industrial Automation Company

Industrial Sensors Division
Sensing Devices and Components Division H.Q.
Shiokoji Horikawa, Shimogyo-ku
Kyoto, 600-8530 Japan

Phone: (81)75-344-7068/Fax: (81)75-344-7107

Printed in Japan
0601-3M (0601) (A)

- Photoelectric Sensor with built-in amplifier is applicable to a wide variety of lines and ensures a longer sensing distance than any other model.
- User-friendly Sensor takes all installation and on-site conditions into consideration.
- Eliminates the influence of installation and on-site conditions, thus increasing the reliability of the line.
- OMRON has been making efforts towards environmental protection by adopting user and environment-friendly measures.
- Greatly saves energy and resources. The economy-oriented age has evolved into the ecology-oriented age.
- Meets a variety of international standards, thus allowing use in any country.



Ordering Information

List of Models

■ Red light □ Infrared light

| Sensing method | Appearance | Connection method | Sensing distance | Model | |
|-------------------------------------|------------|------------------------|------------------|------------|------------|
| | | | | NPN output | PNP output |
| Through-beam | | Pre-wired (see note 3) | | E3Z-T61 | E3Z-T81 |
| | | Connector | | E3Z-T66 | E3Z-T86 |
| Retroreflective (with MSR function) | | Pre-wired (see note 3) | | E3Z-R61 | E3Z-R81 |
| | | Connector | | E3Z-R66 | E3Z-R86 |
| Diffuse-reflective | | Pre-wired (see note 3) | | E3Z-D61 | E3Z-D81 |
| | | Connector | | E3Z-D66 | E3Z-D86 |
| | | Pre-wired (see note 3) | | E3Z-D62 | E3Z-D82 |
| | | Connector | | E3Z-D67 | E3Z-D87 |

- Note:**
1. The Reflector is sold separately. Select the Reflector model most suited to the application.
 2. The sensing distance specified is possible when the E39-R1S used. Figure in parentheses indicate the minimum required distance between the Sensor and Reflector.
 3. Models provided with a 0.5-m cable are available. When ordering, specify the cable length by adding the code "0.5M" to the model number (e.g., E3Z-T61 0.5M).

Nomenclature

Through-beam Models

E3Z-T6□ Receiver

Retroreflective Models

E3Z-R6□

Diffuse-reflective Models

E3Z-D6□

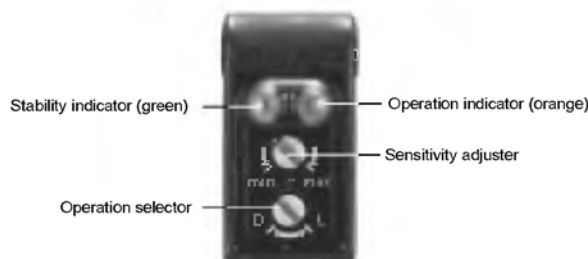

■ Accessories (Order Separately)

Slit for Through-beam Models

| Slit width | Sensing distance (typical) | Minimum sensing object (typical) | Model | Quantity required | Remarks |
|-------------|----------------------------|----------------------------------|----------|--|--|
| 0.5 mm dia. | 50 mm | 0.5 mm dia. | E39-S65A | One each for the emitter and receiver. | These Slits are available for the E3Z-T□□. |
| 1 mm dia. | 200 mm | 1 mm dia. | E39-S65B | | |
| 2 mm dia. | 800 mm | 2 mm dia. | E39-S65C | | |
| 0.5×10 mm | 1 m | 0.7 mm dia. | E39-S65D | | |
| 1×10 mm | 2.2 m | 1.2 mm dia. | E39-S65E | | |
| 2×10 mm | 5 m | 2.4 mm dia. | E39-S65F | | |



Reflectors for Retroreflective Models



| Name | Sensing distance (typical) | Model | Remarks |
|---------------------|------------------------------|---------|--|
| Reflector | 3 m (100 mm) | E39-R1 | Retroreflective models are not provided with Reflectors. The MSR function is available. |
| | 4 m (100 mm) | E39-R1S | |
| | 5 m (100 mm) (see note 2) | E39-R2 | |
| Miniature Reflector | 1.5 m (50 mm) (see note 2) | E39-R3 | |
| Tape Reflector | 700 mm (150 mm) (see note 2) | E39-RS1 | |
| | 1.1 m (150 mm) (see note 2) | E39-RS2 | |
| | 1.4 m (150 mm) (see note 2) | E39-RS3 | |

Note: 1. Figure in parentheses indicates the minimum required distance between the Sensor and Reflector.

2. The actual sensing distance may be reduced to approximately 70% of the typical sensing distance when using a Reflector other than E39-R1 or E39-R1S.



Mounting Brackets

| Appearance | Model |
|---|----------|
|  | E39-L104 |
|  | E39-L43 |
|  | E39-L44 |

| Appearance | Model | Remarks |
|---|---------|--|
|  | E39-L93 | For Sensor adjustment use. Mounted to the aluminum frame rails of conveyors and adjustable with ease. |
|  | E39-L98 | Vertical protective cover bracket |

Note: If a through-beam model is used, order two Mounting Brackets for the emitter and receiver respectively.

Sensor I/O Connectors

| Cable | Appearance | Cable type | | Model |
|----------|---|------------|----------------|-----------------|
| Standard | Straight  | 2 m | Four-wire type | XS3F-M421-402-A |
| | | 5 m | | XS3F-M421-405-A |
| | L-shaped  | 2 m | | XS3F-M422-402-A |
| | | 5 m | | XS3F-M422-405-A |

Specifications

■ Ratings/Characteristics

| Item | Sensing method | Through-beam | Retroreflective with MSR function | Diffuse-reflective | |
|---|--|---|--|---------------------------------------|------------------------------------|
| | NPN output PNP output (see note 3) | | | E3Z-T61/T66 | E3Z-R61/R66 |
| | | E3Z-T81/T86 | E3Z-R81/R86 | E3Z-D81/D86 | E3Z-D82/D87 |
| Sensing distance | | 15 m | 4 m (100 mm)* (when using E39-R1S) 3 m (100 mm)* (when using E39-R1) | White paper (100 × 100 mm): 100 mm | White paper (300 × 300 mm): 1 m |
| Standard sensing object | | Opaque: 12-mm dia. min. | Opaque: 75-mm dia. min. | --- | --- |
| Hysteresis | | --- | --- | 20% max. of setting distance | |
| Directional angle | | Both emitter and receiver: 3 to 15° | 2 to 10° | --- | |
| Light source (wave length) | | Infrared LED (860 nm) | Red LED (680 nm) | Infrared LED (860 nm) | |
| Power supply voltage | | 12 to 24 VDC ±10% including 10% (p-p) max. ripple | | | |
| Current consumption | | Emitter: 15 mA Receiver: 20 mA | 30 mA max. | | |
| Control output | | Load power supply voltage: 26.4 V max. Load current: 100 mA max. (Residual voltage: 1 V max.) Open collector output (NPN or PNP depending on model) L-ON/D-ON selectable | | | |
| Circuit protection | | Protection from load short-circuit and reversed power supply connection | Protection from reversed power supply connection, output short-circuit, and mutual interference protection | | |
| Response time | | Operation or reset: 1 ms max. | | | |
| Sensitivity adjustment | | One-turn adjuster | | | |
| Ambient illumination (receiver side) | | Incandescent lamp: 3,000 lx max. Sunlight: 10,000 lx max. | | | |
| Ambient temperature | | Operating: -25°C to 55°C/Storage: -40°C to 70°C (with no icing or condensation) | | | |
| Ambient humidity | | Operating: 35% to 85%/Storage: 35% to 95% (with no condensation) | | | |
| Insulation resistance | | 20 MΩ min. at 500 VDC | | | |
| Dielectric strength | | 1,000 VAC, 50/60 Hz for 1 min | | | |
| Vibration resistance | | 10 to 55 Hz, 1.5-mm double amplitude or 300 m/s ² for 2 hours each in X, Y, and Z directions | | | |
| Shock resistance | | Destruction: 500 m/s ² 3 times each in X, Y, and Z directions | | | |
| Degree of protection | | IP67 (IEC60529) | | | |
| Connection method | | 500-mm-thick pre-wired cable (standard length: 2 m) with M8 connector | | | |
| Indicator | | Operation indicator (orange) Stability indicator (green) Emitter has power indicator (orange) only. | | | |
| Weight (packed state) | Pre-wired cable (2 m) | Approx. 120 g | Approx. 65 g | | |
| | Connector | Approx. 30 g | Approx. 20 g | | |
| Material | Case | PBT (polybutylene terephthalate) | | | |
| | Lens | Methacrylate resin | | | |
| Accessories | | Instruction manual (The Reflector or Mounting Bracket is not provided with any of the above models.) | | | |

Note: *Figures in parentheses indicate the minimum required distances between the Sensors and Reflectors.

Engineering Data

Parallel Operating Range (Typical)

Through-beam Models

E3Z-T□1 (T□6)

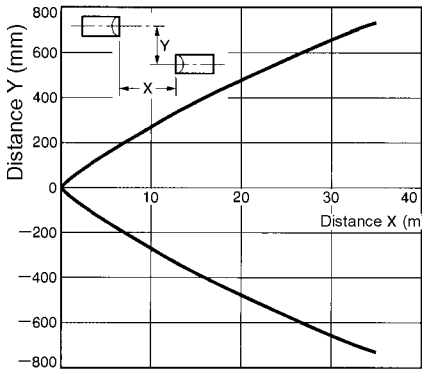

Through-beam Models

E3Z-T□1 (T□6) and Slit

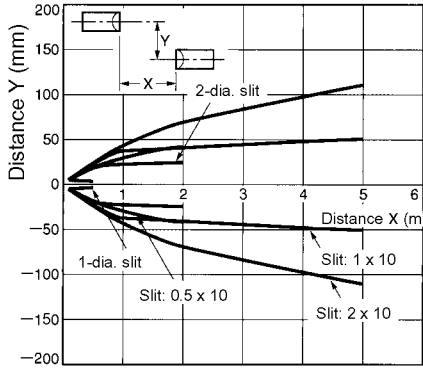

Retroreflective Models

E3Z-R□1 (R□6) and Reflector

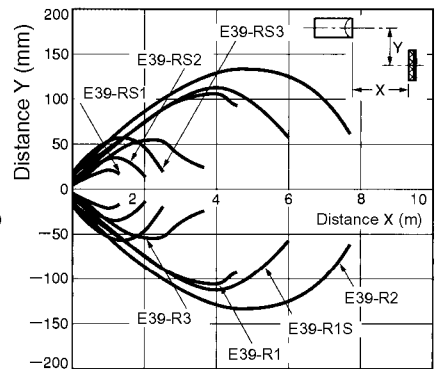

Operating Range (Typical)

Diffuse-reflective Models

E3Z-D□1 (D□6)

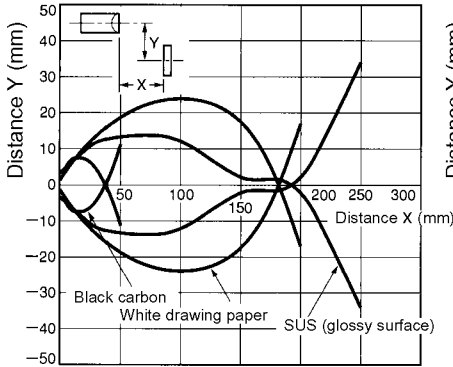

Diffuse-reflective Models

E3Z-D□2 (D□7)

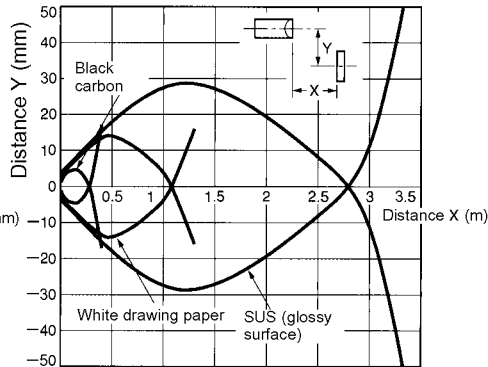

■ Excess Gain Ratio vs. Distance (Typical)

Through-beam Models

E3Z-T□1 (T□6)

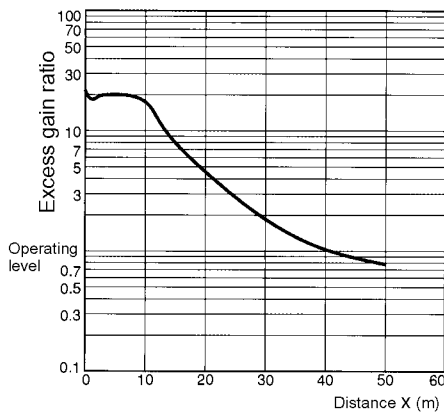

Retroreflective Models

E3Z-R□1 (R□6) and Reflector

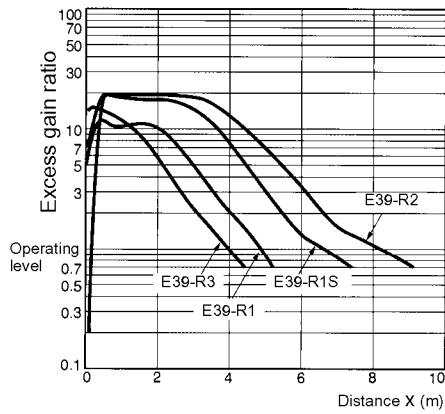

Diffuse-reflective Models

E3Z-D□1 (D□6)

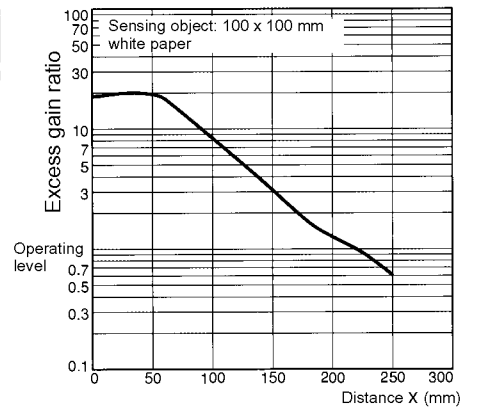

Diffuse-reflective Model

E3Z-D□2 (D□7)

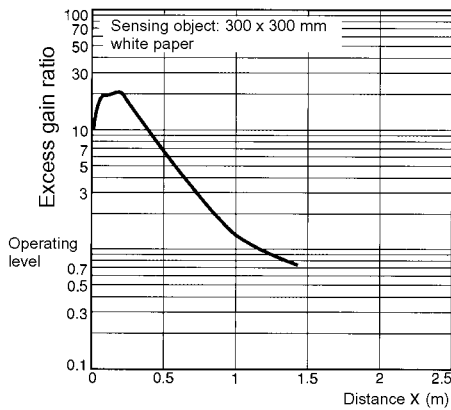

■ Sensing Object Size vs. Sensing Distance (Typical)

Diffuse-reflective Models

E3Z-D□1 (D□6)

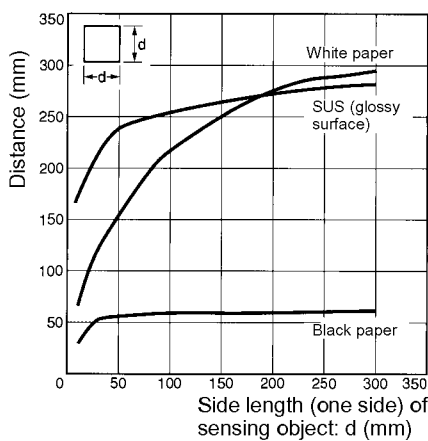

Diffuse-reflective Models

E3Z-D□2 (D□7)

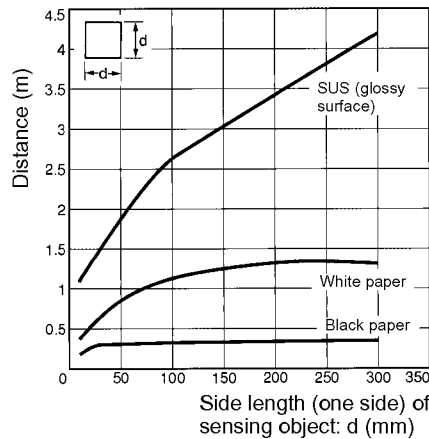

Operation

NPN Output

| | | |
|---------------------------------|---|----------------|
| Model | E3Z-T61/-T66/-R61/-R66/-D61/-D66/-D62/-D67 | |
| Output transistor status | Light ON | Dark ON |
| Timing chart | | |
| Mode selector | Light ON (L/ON) | Dark ON (D/ON) |
| Output circuit | <p style="text-align: center;">Connector Pin Arrangement</p> <p style="text-align: center;">Pin 2 is open.</p> | |
| | <p style="text-align: center;">Connector Pin Arrangement</p> <p style="text-align: center;"> Pins 2, 4 are open. </p> | |

PNP Output

| | | |
|---------------------------------|---|----------------|
| Model | E3Z-T81/-T86/-R81/-R86/-D81/-D86/-D82/-D87 | |
| Output transistor status | Light ON | Dark ON |
| Timing chart | | |
| Mode selector | Light ON (L/ON) | Dark ON (D/ON) |
| Output circuit | <p style="text-align: center;">Connector Pin Arrangement</p> <p style="text-align: center;">Pin 2 is open.</p> | |
| | <p style="text-align: center;">Connector Pin Arrangement</p> <p style="text-align: center;"> Pins 2, 4 are open. </p> | |

Structure of Sensor I/O Connector

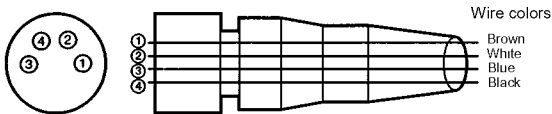

XS3F-M421-402-A XS3F-M421-405-A
 XS3F-M422-402-A XS3F-M422-405-A

| Classification | Wire color | Connector pin No. | Use |
|----------------|------------|-------------------|--------------------|
| DC | Brown | ① | Power supply (+V) |
| | White | ② | --- |
| | Blue | ③ | Power supply (0 V) |
| | Black | ④ | Output |

Note: Pin 2 is not used.

Dimensions

Note: All units are in millimeters unless otherwise indicated.

■ Sensors

Through-beam (Pre-wired Models)

E3Z-T61
E3Z-T81

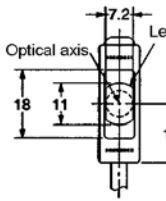
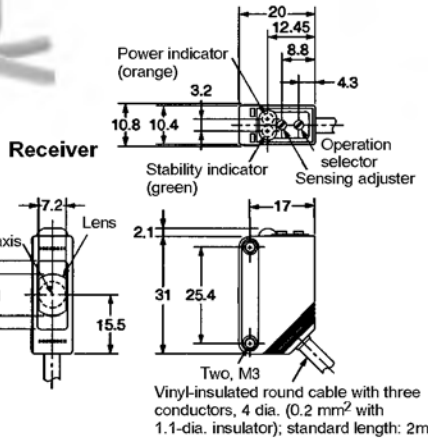
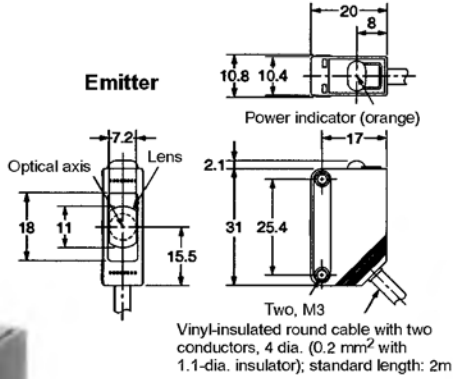

Through-beam (Connector Models)

E3Z-T66
E3Z-T86

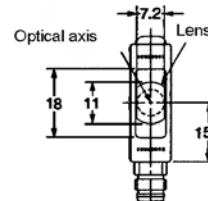
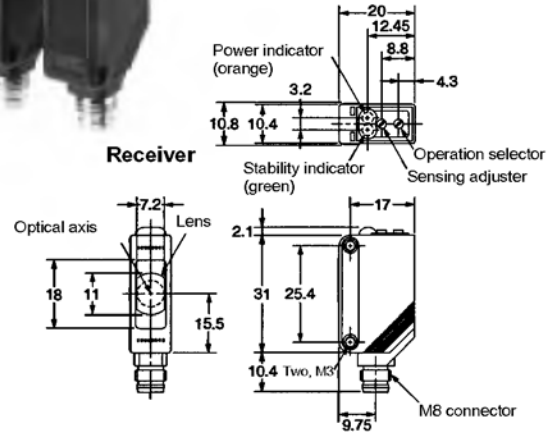
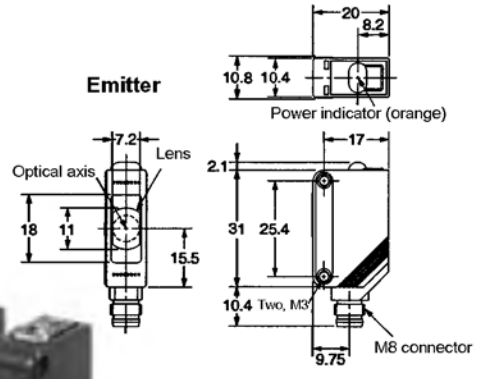

Retroreflective Models (Pre-wired Models)

E3Z-R61
E3Z-R81

Diffuse-reflective Models

E3Z-D61
E3Z-D62
E3Z-D81
E3Z-D82

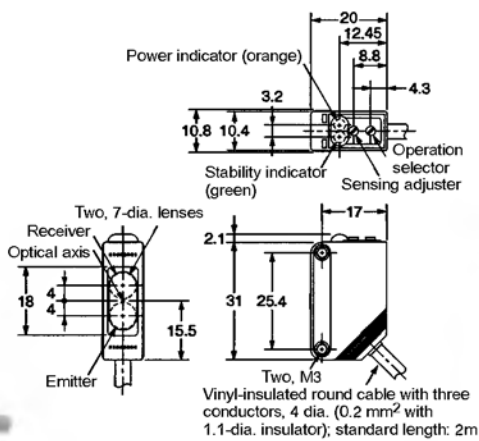

Retroreflective Models (Connector Models)

E3Z-R66
E3Z-R86

Diffuse-reflective Models

E3Z-D66
E3Z-D67
E3Z-D86
E3Z-D87

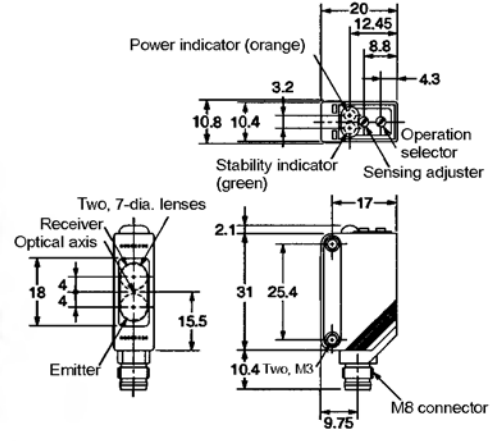

Tape Reflectors

E39-RS1

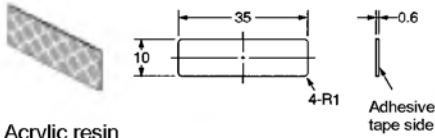

Material: Acrylic resin

E39-RS2

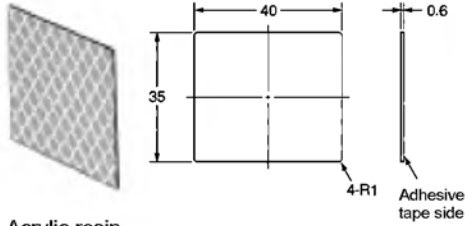

Material: Acrylic resin

E39-RS3

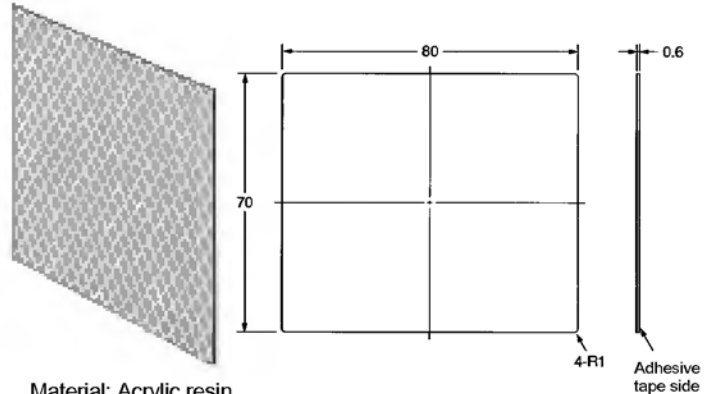

Material: Acrylic resin

Mounting Brackets

E39-L104

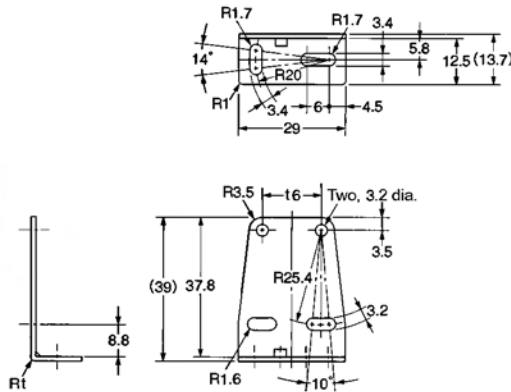

Material: SUS304 stainless steel

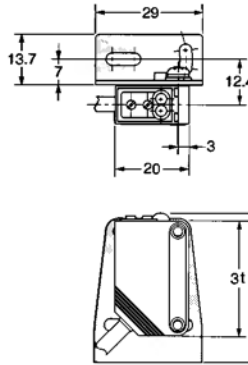

With Mounting Bracket (E3Z-D62)

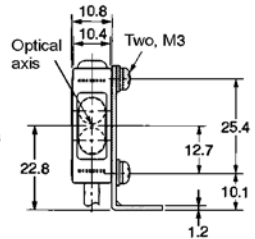

E39-L43

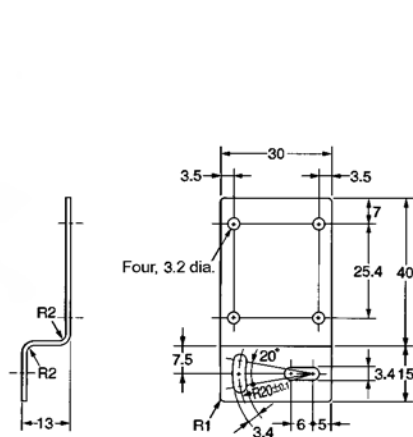

Material: SUS304 stainless steel

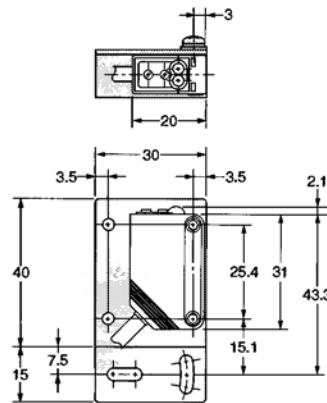

With Mounting Bracket (E3Z-D62)

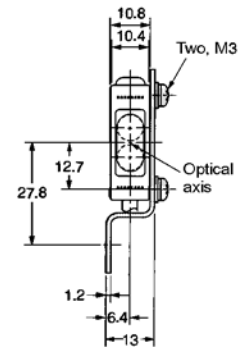

Sensor I/O Connectors

Straight

XS3F-M421-402-A (L=2 m)
XS3F-M421-405-A (L=5 m)

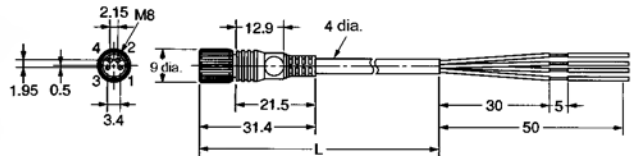

L-shaped

XS3F-M422-402-A (L=2 m)
XS3F-M422-405-A (L=5 m)

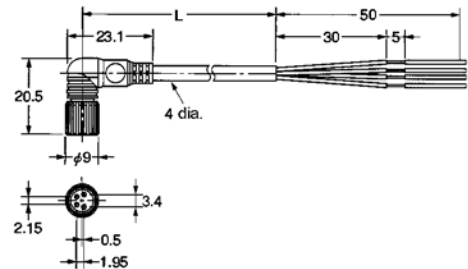

Precautions

Be sure to abide by the following precautions for the safe operation of the Sensor.

Wiring

Power Supply Voltage

Make sure that the power supply to the Sensor is within the rated voltage range and do not apply 100 VAC or more if the Sensor is a DC model, or otherwise the Sensor may explode or burn.

Load Short-circuiting

Do not short-circuit the load, otherwise the Sensor may be damaged.

■ Correct Use

Settings

Power Reset Time

The Sensor is ready to operate 100 ms after the Sensor is turned ON. If the load and Sensor are connected to independent power supplies respectively, be sure to turn ON the Sensor before turning the load ON.

Connections

M8 Metal Connector

- Be sure to connect or disconnect the metal connector after turning OFF the Sensor.
- Hold the connector cover to connect or disconnect the metal connector.
- Secure the connector cover by hand. Do not use any pliers, otherwise the connector may be damaged.
- The proper tightening torque range is between 0.3 and 0.4 N • m. Be sure to tighten the connector securely, otherwise the specified degree of protection may not be maintained or the connector may be disconnected due to vibration.

Wiring Mistakes

Do not make mistakes in wiring, such as mistakes in polarity, otherwise the Sensor may be damaged.

Connection without Load

Do not connect power supply to the Sensor with no load connected, otherwise the internal elements may explode or burn.

Operating Environment

Do not use the Sensor in locations with explosive or flammable gas.

Mounting

Sensor Mounting

Use M3 screws to mount the sensor and tighten each screw to a maximum torque of 0.53 N • m.

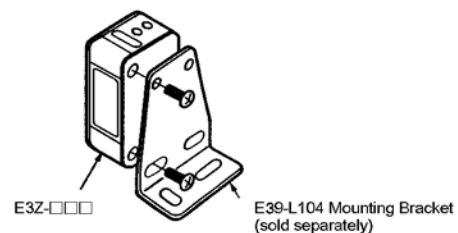

Adjustment

**Slits for Through-beam Models
(E39-S65A/B/C/D/E/F (Sold Separately))**

| | |
|---|--|
| | |
| <p>Mounting method</p> <ol style="list-style-type: none"> 1. Hook the upper protruding portion of the Slit to the upper indented mounting portion of the Sensor and adjust the position of the Slit so that the Slit will be in parallel to the lens side of the Sensor. 2. Press the lower protruding portion of the Slit onto the indented mounting portion of the Sensor until the Slit snaps in. | |
| <p>Mounting condition</p> | <p>Side view Front view</p> |
| <p>Removal method</p> <ol style="list-style-type: none"> 1. Press the upper portion of the Slit. 2. Disconnect the lower protruding portion of the Slit from the Sensor and remove the Slit. | |

ALL DIMENSIONS SHOWN ARE IN MILLIMETERS.
 To convert millimeters into inches, multiply by 0.03937. To convert grams into ounces, multiply by 0.03527.

Cat. No. E308-E1-1 **In the interest of product improvement, specifications are subject to change without notice.**

OMRON Corporation
 Industrial Automation Company

Industrial Sensors Division
 Sensing Devices and Components Division H.Q.
 28th Fl., Crystal Tower Bldg.,
 1-2-27, Shiromi, Chuo-ku,
 Osaka 540-6028 Japan
 Phone: (81)6-6949-6012 Fax: (81)6-6949-6021

Printed in Japan
 0799-5M (0799) ④

- Switching between background and foreground suppression (BGS/FGS) enables detecting a variety of objects under various background/foreground conditions.
- Influence of external interference, including inverter fluorescent lighting, minimized with unique avoidance algorithm.
- Red beam for easy spot position confirmation.
- Almost no differences in detection distances for different colors.
- Minimal hysteresis to enable detecting small steps (2/3rds of previous models: E3Z-LS20□4S).
- Same compact size as the E3Z Series: Use the same Mounting Brackets.



Ordering Information

■ Sensors

| Sensing method | Appearance | Connection method | Sensing distance (white paper) | Model | |
|-------------------|------------|--------------------------------------|--------------------------------|------------|------------|
| | | | | NPN output | PNP output |
| Distance-settable | | Pre-wired (2-m cable) (See note.) | | E3Z-LS61 | E3Z-LS81 |
| | | M8 Connector | | E3Z-LS66 | E3Z-LS86 |

Note: Models are also available with 0.5-m cables. Specify the cable length after the model number (example: E3Z-LS61 0.5M).

■ Accessories (Order Separately)

Sensor I/O Connectors

| Cable specification | Appearance | Cable type | | Model |
|---------------------|------------|------------|--------|-----------------|
| | | Length | Wires | |
| Standard M8 cable | Straight | 2 m | 4-wire | XS3F-M421-402-A |
| | | 5 m | | XS3F-M421-405-A |
| | L-shaped | 2 m | 4-wire | XS3F-M422-402-A |
| | | 5 m | | XS3F-M422-405-A |

Note: Refer to page 11 for details on Mounting Brackets.

Application Example

Simple Detection of Glossy, Uneven Objects

BGS (Background Suppression)

Selectable by Changing Cable Connection

FGS (Foreground Suppression)

Objects beyond the set distance, such as the conveyor, will not be detected. The hysteresis is 10% or less, so at a set distance of 40 mm, steps with a thickness of 4 mm can be detected on objects.

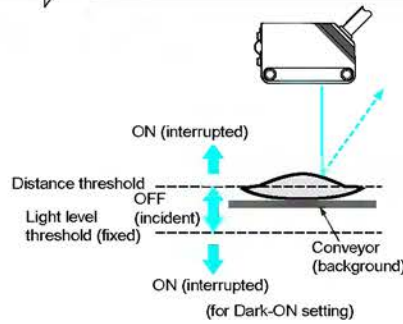
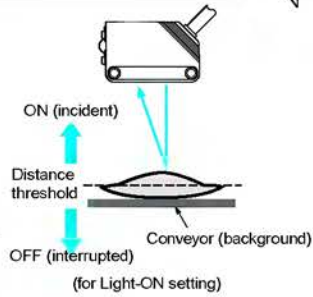

Glossy, uneven objects are reliably detected because the OFF (incident) status occurs only when the conveyor is detected, and ON (interrupted) status occurs only when an object exists or when reflected light is not returned to the Sensor. (Depending on the shape of the object, an OFF-delay timer may be required.)

Specifications

■ Ratings/Characteristics

| Item | Sensing method | | Distance-settable | |
|---|--|--|-------------------|----------|
| | NPN output | E3Z-LS61 | | E3Z-LS66 |
| | PNP output | E3Z-LS81 | | E3Z-LS86 |
| Sensing distance | BGS | White or black paper (100 x 100 mm): 20 mm to set distance | | |
| | FGS | White paper (100 x 100 mm): Set distance to 200 mm min. Black paper (100 x 100 mm): Set distance to 160 mm min. | | |
| Setting range | White paper (100 x 100 mm): 40 to 200 mm Black paper (100 x 100 mm): 40 to 160 mm | | | |
| Hysteresis | 10% of set distance max. (Refer to <i>Hysteresis vs. Sensing Distance</i> on page 4.) | | | |
| Reflectivity characteristic (black/white error) | 10% of set distance max. | | | |
| Light source (wavelength) | Red LED (680 nm) | | | |
| Power supply voltage | 12 to 24 VDC ±10%, ripple (p-p) 10% max. | | | |
| Current consumption | 30 mA max. | | | |
| Control output | Load power supply voltage 26.4 VDC max., load current 100 mA max. (residual voltage 1 V max.) Open collector output (NPN or PNP depending on model) Light-ON/Dark-ON switch selectable | | | |
| BGS/FGS selection | BGS: Open or connected to GND FGS: Connected to Vcc | | | |
| Protective circuits | Reverse polarity protection, output short-circuit protection, mutual interference prevention | | | |
| Response time | Operation or reset: 1 ms max. | | | |
| Distance setting | 5-turn endless adjustor | | | |
| Ambient illumination | Incandescent lamp: 3,000 lx max.; Sunlight: 10,000 lx max. | | | |
| Ambient temperature | Operating: -25 to 55°C, Storage: -40 to 70°C (with no icing or condensation) | | | |
| Ambient humidity | Operating: 35% to 85%, Storage: 35% to 95% (with no condensation) | | | |
| Insulation resistance | 20 MΩ min. at 500 VDC | | | |
| Dielectric strength | 1,000 VAC at 50/60 Hz for 1 minute | | | |
| Vibration resistance (destruction) | 10 to 55 Hz, 1.5-mm double amplitude for 2 hours each in X, Y, and Z directions | | | |
| Shock resistance (destruction) | 500 m/s ² for 3 times each in X, Y, and Z directions | | | |
| Degree of protection | IEC 60529 IP67 | | | |
| Connection method | Pre-wired (standard length: 2 m/0.5 m) | | M8 connector | |
| Indicators | Operation indicator (orange), stability indicator (green) | | | |
| Weight (Packed state) | Pre-wired Sensors, 2 m: Approx. 65 g | | Approx. 20 g | |
| Material | Case | PBT (polybutylene terephthalate) | | |
| | Lens | Denaturated polyallylate | | |
| Accessories | Instruction sheet (Mounting Brackets must be purchased separately.) | | | |

Engineering Data

Operating Range

BGS

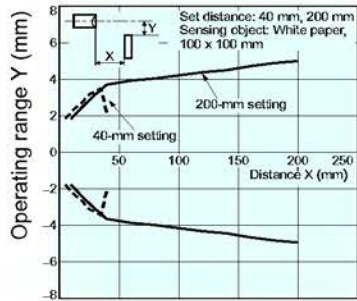

FGS

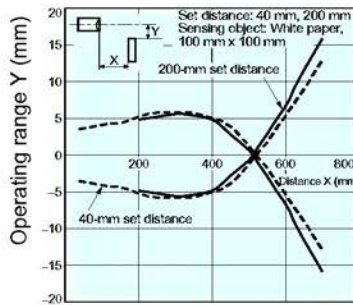

Spot Diameter vs. Sensing Distance

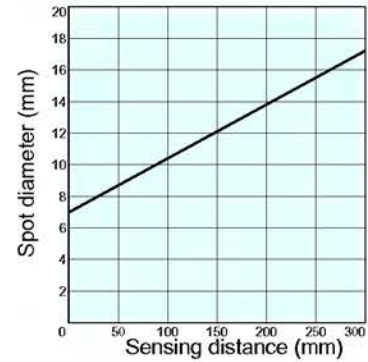

Inclination Characteristics

Vertical

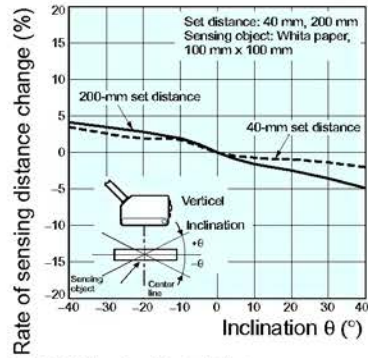

Horizontal

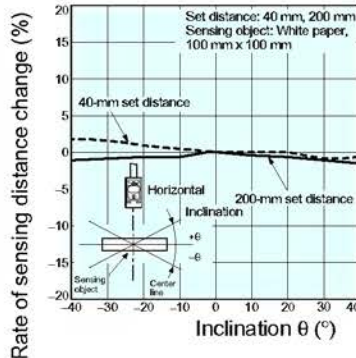

Short-distance Characteristic

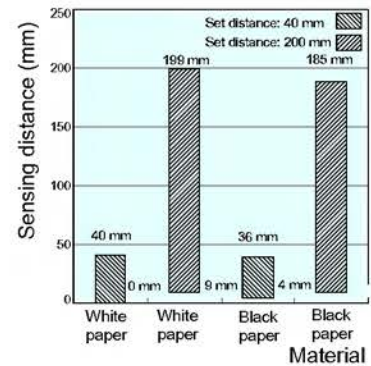

FGS Mode Set Distance vs. Sensing Range

White Paper

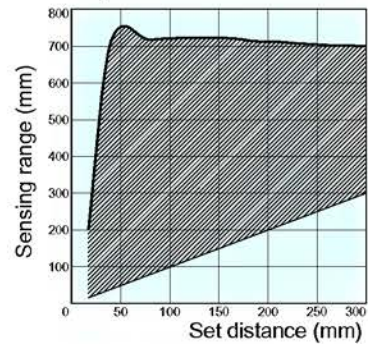

Black Paper

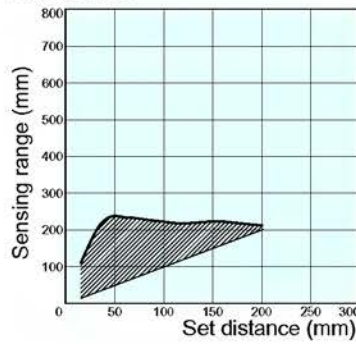

Hysteresis vs. Sensing Distance

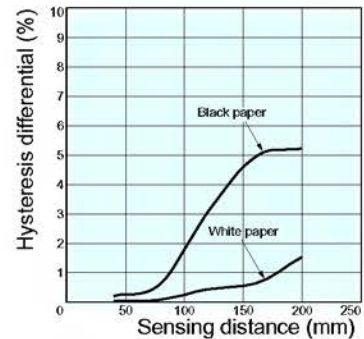

Sensing Distance vs. Material

At Set Distance of 40 mm

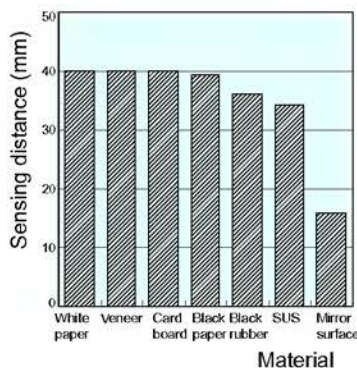

At Set Distance of 200 mm

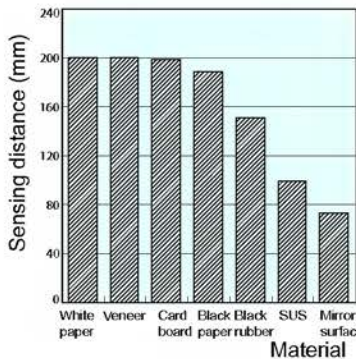

Operation

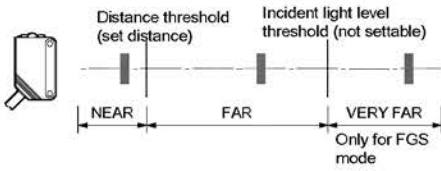

Note: The VERY FAR region is supported only for FGS. The incident light level threshold is fixed and cannot be set.

■ NPN Output

| Model | Output transistor status | Timing chart | Mode selection switch | BGS/FGS selection method | Output circuit |
|----------------------|--------------------------|--------------|-----------------------|---|----------------|
| E3Z-LS61 E3Z-LS66 | Light ON | | L side (L/ON) | BGS: Either leave the pink wire (2) open or connect it to the blue wire (3). | |
| | Dark ON | | D side (D/ON) | | |
| | Light ON | | L side (L/ON) | FGS: Connect the pink wire (2) to the brown wire (1). | |
| | Dark ON | | D side (D/ON) | | |

Connector Pin Arrangement



■ PNP Output

| Model | Output transistor status | Timing chart | Mode selection switch | BGS/FGS selection method | Output circuit |
|----------------------|--------------------------|--------------|-----------------------|---|----------------------------------|
| E3Z-LS81 E3Z-LS86 | Light ON | | L side (L/ON) | BGS: Either leave the pink wire (2) open or connect it to the blue wire (3). | <p>Connector Pin Arrangement</p> |
| | Dark ON | | D side (D/ON) | | |
| | Light ON | | L side (L/ON) | FGS: Connect the pink wire (2) to the brown wire (1). | |
| | Dark ON | | D side (D/ON) | | |

■ Connectors (Sensor I/O Connectors)

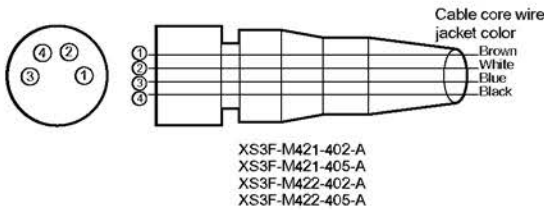

| Class | Wire jacket color | Connector pin No. | Application |
|--------|-------------------|-------------------|--------------------|
| For DC | Brown | ① | Power supply (+V) |
| | White | ② | BGS/FGS selection |
| | Blue | ③ | Power supply (0 V) |
| | Black | ④ | Output |

Nomenclature



Dimensions

Pre-wired Sensors E3Z-LS61 E3Z-LS81

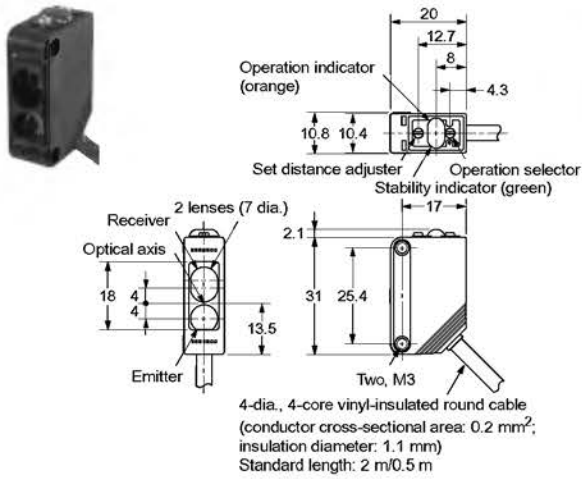

Sensors with M8 Connectors E3Z-LS66 E3Z-LS86

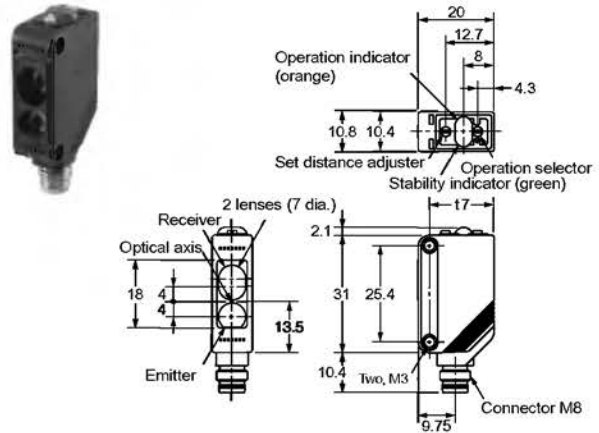

Precautions

⚠ Caution

Do not connect an AC power supply to the Sensor. If AC power (100 VAC or more) is supplied to the Sensor, it may explode or burn.

Be sure to abide by the following precautions for the safe operation of the Sensor.

Wiring

Power Supply Voltage and Output Load Power Supply Voltage

Make sure that the power supply to the Sensor is within the rated voltage range. If a voltage exceeding the rated voltage range is supplied to the Sensor, it may explode or burn.

Load Short-circuiting

Do not short-circuit the load, otherwise the Sensor may be damaged.

Connection without Load

Do not connect power supply to the Sensor with no load connected, otherwise the internal elements may explode or burn.

Operating Environment

Do not use the Sensor in locations with explosive or flammable gas.

■ Correct Use

Design

Power Reset Time

The Sensor is ready to operate 100 ms after the Sensor is turned ON. If the load and Sensor are connected to independent power supplies respectively, be sure to turn ON the Sensor before supplying power to the load.

Wiring

Avoiding Malfunctions

If using the Photoelectric Sensor with an inverter or servomotor, always ground the FG (frame ground) and G (ground) terminals, otherwise the Sensor may malfunction.

Mounting

Mounting the Sensor

- If Sensors are mounted face-to-face, make sure that the optical axes are not in opposition to each other. Otherwise, mutual interference may result.
- Always install the Sensor carefully so that the aperture angle range of the Sensor will not cause it to be directly exposed to intensive light, such as sunlight, fluorescent light, or incandescent light.
- Do not strike the Photoelectric Sensor with a hammer or any other tool during the installation of the Sensor, or the Sensor will lose its water-resistive properties.
- Use M3 screws to mount the Sensor.
- When mounting the case, make sure that the tightening torque applied to each screw does not exceed 0.54 N·m.

M8 Connector

- Always turn OFF the power supply to the Sensor before connecting or disconnecting the metal connector.
- Hold the connector cover to connect or disconnect it.
- Secure the connector cover by hand. Do not use pliers, otherwise the connector may be damaged.

- If the connector is not connected securely, it may be disconnected by vibration or the proper degree of protection of the Sensor may not be maintained.

Mounting Directions

- Make sure that the sensing side of the Sensor is parallel with the surface of the sensing objects. Normally, do not incline the Sensor towards the sensing object.

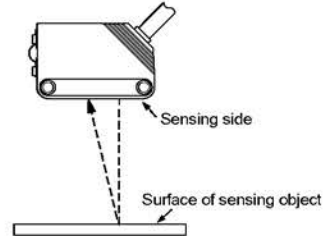

If the sensing object has a glossy surface, however, incline the Sensor by 5° to 10° as shown in the illustration, provided that the Sensor is not influenced by background objects.

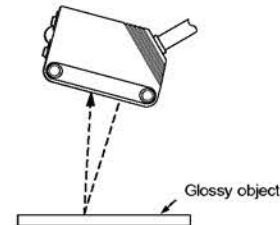

- If there is a mirror-like object below the Sensor, the Sensor may not operate stably. Therefore, incline the Sensor or separate the Sensor from the mirror-like object as shown below.

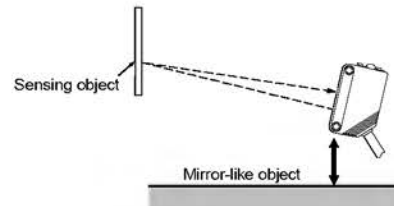

- Do not install the Sensor in the wrong direction. Refer to the following illustration.

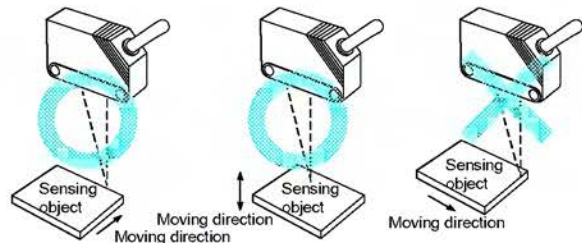

Install the Sensor as shown in the following illustration if each sensing object greatly differs in color or material.

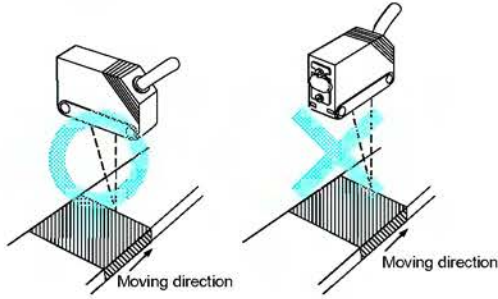

Adjustments

Indicator Operation

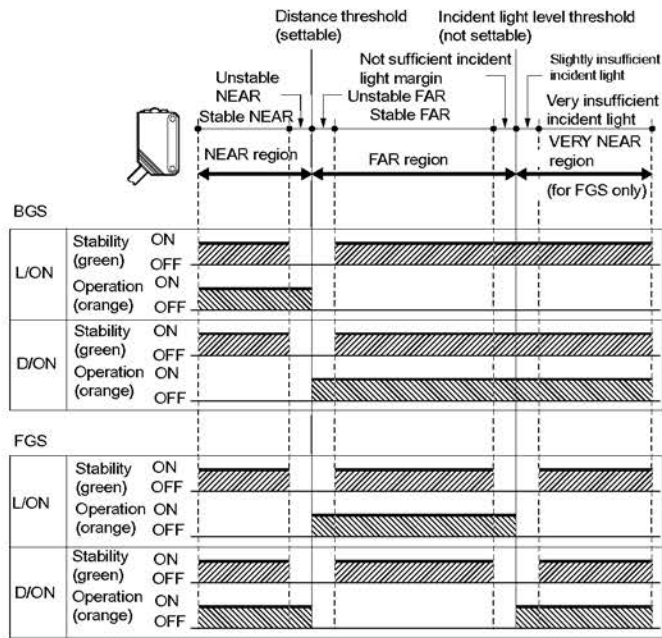

- Note:**
1. If the stability indicator is lit, the detection/no detection status is stable within the rated ambient operating temperature (-25 to 55°C).
 2. The VERY FAR region is supported only for FGS. The incident light threshold is fixed and cannot be set. The distance to the incident light threshold depends on the color and gloss of the sensing object's surface.





Inspection and Maintenance

Cleaning

Never use paint thinners or other organic solvents to clean the surface of the product.









E3Z Series Lineup

■ Complete E3Z Series Lineup: Photoelectric Sensors for the 21st Century





| Sensing method Item | Distance-settable (NEW) | Diffuse reflective | | Narrow-beam diffuse reflective | Retroflective | Retroflective for PET bottles | | Through-beam | | Grooved type |
|---------------------------|--|--|-----|---|--|---|----------------------------|--|------------------|---|
| Appearance |  | | |  | |  | |  | |  |
| Model | E3Z-LS | E3Z-D | 1 m | E3Z-L | E3Z-R | E3Z-B | | E3Z-T | | E3Z-G |
| Sensing distance | 20 mm to set distance (BGS mode) Set distance to 200 mm min. (FGS mode) | 5 to 100 mm (wide vision) | | 90 ± 30 mm | 4 m (100 mm) (See note 1.) | 500 mm (80 mm) (See note 1.) | 2 m (500 mm) (See note 1.) | 15 m | 10 m | 25 mm |
| Light source (wavelength) | Red LED (680 nm) | Infrared LED (860 nm) | | Red LED (670 nm) | Red LED (680 nm) | | | Infrared LED (860 nm) | Red LED (700 nm) | Infrared LED (940 nm) |
| Power supply voltage | 12 to 24 VDC ±10%, ripple (p-p) 10% max. | | | | | | | | | |
| Current consumption | 30 mA max. | | | | | | | Emitter: 15 mA Receiver: 20 mA | | 25 mA max. |
| Control outputs | Load power supply voltage 26.4 VDC max., load current 100 mA max. (residual voltage 1 V max.) Open collector output (NPN or PNP depending on model) Light-ON/Dark-ON switch selectable | | | | | | | | | |
| Protective circuits | Reverse polarity protection, output short-circuit protection, mutual interference prevention (Mutual interference prevention is not provided on E3Z-T.) | | | | | | | | | |
| Response time | Operation or reset: 1 ms max. | | | | | | | | | |
| Sensitivity adjustment | 5-turn endless adjuster | Single-turn adjuster | | | | | | | | --- |
| Ambient temperature | Operating: -25 to 55°C, Storage: -40 to 70°C (with no icing or condensation) | | | | | | | | | |
| Ambient humidity | Operating: 35% to 85%, Storage: 35% to 95% (with no condensation) | | | | | | | | | |
| Protective structure | IEC 60529 IP67 | | | | | | | | | IEC 60529 IP64 |
| Connection method | Pre-wired (standard length: 2 m/0.5 m) or M8 connector | Pre-wired (standard length: 2 m/0.5 m), M8 connector, or M12 connector relay (0.3 m) | | Pre-wired (standard length: 2 m/0.5 m) or M8 connector | Pre-wired (standard length: 2 m/0.5 m), M8 connector, or M12 connector relay (0.3 m) | Pre-wired (standard length: 2 m/0.5 m) or M8 connector | | Pre-wired (standard length: 2 m/0.5 m), M8 connector, or M12 connector relay (0.3 m, infrared type only) | | Pre-wired (standard length: 2 m/0.5 m) or M8 connector relay (0.3 m) |
| Datasheet catalog number | E327-01 | E308-01A | | E311-01 | E308-01A | E316-01 | | Infrared type: E319-01A Red type: E308-01A | | E320-01 |

- Note:**
1. The sensing distance is for when an E39-R1S Reflector is used. The minimum distance between the Reflector and Sensor is given in parentheses.
 2. For details, refer to the main *Sensors* catalog (X042) and individual catalogs.

Mounting Brackets (Same for Entire E3Z Series)

| Appearance | Model | Qty | Remarks | Appearance | Model | Qty | Remarks |
|---|----------|-----|--|---|----------|-------|--|
|  | E39-L153 | 1 | Mounting Bracket |  | E39-L150 | 1 set | Sensor Adjustors For easy mounting and adjustment with aluminum frames and rails, such as those on conveyors For horizontal adjustment |
|  | E39-L104 | 1 | | | | | |
|  | E39-L43 | 1 | Horizontal Mounting Bracket |  | E39-L151 | 1 set | |
|  | E39-L142 | 1 | Horizontal Protective Cover/Mounting Bracket | | | | |
|  | E39-L44 | 1 | Rear-connecting Mounting Bracket | | | | |
|  | E39-L98 | 1 | Protective Cover/Mounting Bracket |  | E39-L144 | 1 set | Compact Protective Cover/Mounting Bracket (for E3Z only) |

Sensor I/O Connectors (Same for Entire E3Z Series)

| Size | Cable specifications | Shape | Cable type | | Model number |
|----------------|----------------------|---|------------|--------|-----------------|
| M8 | Standard cable | Straight  | 2 m | 4-wire | XS3F-M421-402-A |
| | | | 5 m | | XS3F-M421-405-A |
| | | L-shaped  | 2 m | | XS3F-M422-402-A |
| | | | 5 m | | XS3F-M422-405-A |
| M12 (for -M1J) | | Straight  | 2 m | 3-wire | XS2F-D421-DC0-A |
| | | | 5 m | | XS2F-D421-GC0-A |
| | | L-shaped  | 2 m | | XS2F-D422-DC0-A |
| | | | 5 m | | XS2F-D422-GC0-A |

ALL DIMENSIONS SHOWN ARE IN MILLIMETERS.

To convert millimeters into inches, multiply by 0.03937. To convert grams into ounces, multiply by 0.03527.

Cat. No. E327-E1-01 **In the interest of product improvement, specifications are subject to change without notice.**

OMRON Corporation

Industrial Automation Company

Industrial Sensors Division

Sensing Devices & Components Division H.Q.

3-2, Narutani, Nakayama-cho, Ayabe-shi,
Kyoto, 623-0105 Japan

Tel: (81)773-43-4078 Fax: (81)773-43-4030

Printed in Japan
0302-2M (0302) (B)