

A Wide Range of Models with 5- to 40-A Output Currents and Up to 480-VAC/200-VDC Output Voltages

- All models feature the same compact dimensions to provide a uniform mounting pitch.
- Built-in varistor effectively absorbs external surges.
- Operation indicator (red LED) enables monitoring operation.
- Protective cover for greater safety.
- Standard models approved by UL/CSA and -UTU models by VDE (TUV).



Ordering Information

Isolation	Zero cross function	Indicator	Rated output load (Applicable output load)	Rated input voltage	Model		
Phototriac	Yes	Yes	5 A at 24 to 240 VAC* (19 to 264 VAC)	5 to 24 VDC	G3NA-205B		
Photocoupler				100 to 120 VAC			
				200 to 240 VAC			
Phototriac	---	Yes	10 A at 24 to 240 VAC* (19 to 264 VAC)	5 to 24 VDC	G3NA-210B		
Photocoupler				100 to 120 VAC			
				200 to 240 VAC			
			10 A at 200 to 480 VAC* (180 to 528 VAC)	5 to 24 VDC	G3NA-410B		
				100 to 240 VAC			
				10 A at 5 to 200 VDC* (4 to 220 VDC)	5 to 24 VDC	G3NA-D210B	
			100 to 240 VAC				
Phototriac	Yes	Yes	20 A at 24 to 240 VAC* (19 to 264 VAC)	5 to 24 VDC	G3NA-220B		
Photocoupler				100 to 120 VAC			
				200 to 240 VAC			
				20 A at 200 to 480 VAC* (180 to 528 VAC)	5 to 24 VDC	G3NA-420B	
					100 to 240 VAC		
Phototriac			Yes	Yes	40 A at 24 to 240 VAC* (19 to 264 VAC)	5 to 24 VDC	G3NA-240B
Photocoupler						100 to 120 VAC	
	200 to 240 VAC						
		40 A at 200 to 480 VAC* (180 to 528 VAC)			5 to 24 VDC	G3NA-440B	
			100 to 240 VAC				
			50 A at 200 to 480 VAC* (180 to 528 VAC)	5 to 24 VDC	G3NA-450B		

*Loss time increases under 75 VAC. (Refer to page 148.)

Note: When ordering a TÜV-approved model, add "-UTU" to the model number as shown below:
Example: G3NA-210B-UTU

■ Accessories (Order Separately)

Heat Sink

The following heat sinks are thin and can be DIN-track mounted (except Y92B-P250).

See *Dimensions* for details.

Model	Applicable SSR
Y92B-N50	G3NA-205B, G3NA-210B, G3NA-D210B, G3NA-410B, G3NE-205T(L), G3NE-210T(L)
Y92B-N100	G3NA-220B, G3NA-420B, G3NE-220T(L)
Y92B-N150	G3NA-240B, G3NA-440B
Y92B-P250	G3NA-450B

Low-cost Models

Model	Applicable SSR
Y92B-A100	G3NA-205B, G3NA-210B, G3NA-D210B, G3NA-220B, G3NA-410B, G3NA-420B
Y92B-A150N	G3NA-240B, G3NA-440B
Y92B-A250	G3NA-440B

Mounting Bracket

Used to mount the G3NA with a mounting dimension of 56 mm.

Model	Applicable SSR
R99-11	G3NA-240B, G3NA-440B

See *Dimensions* for details. (Refer to page 148.)

Specifications

■ Ratings

Input (Ambient Temperature: 25°C)

Model	Rated voltage	Operating voltage	Impedance	Voltage level	
				Must operate voltage	Must release voltage
G3NA-2□□B	5 to 24 VDC	4 to 32 VDC	7 mA max.*	4 VDC max.	1 VDC min.
	100 to 120 VAC	75 to 132 VAC	36 kΩ±20%	75 VAC max.**	20 VAC min.**
	200 to 240 VAC	150 to 264 VAC	72 kΩ±20%	150 VAC max.**	40 VAC min.**
G3NA-4□□B	5 to 24 VDC	4 to 32 VDC	5 mA max.*	4 VDC max.	1 VDC min.
	G3NA-D210B	100 to 240 VAC	75 to 264 VAC	72 kΩ±20%	75 VAC max.

Note: The input impedance is measured at the maximum value of the rated supply voltage (for example, with the model rated at 100 to 120 VAC, the input impedance is measured at 120 VAC).

*With constant current input circuit system. The impedance for the G3NA-□□□B-UTU is 15 mA max.

**Refer to the *Engineering Data* for further details.

Output

Model	Applicable load				
	Rated load voltage	Load voltage range	Load current		Inrush current
			With heat sink*	Without heat sink	
G3NA-205B	24 to 240 VAC	19 to 264 VAC	0.1 to 5 A	0.1 to 3 A	60 A (60 Hz, 1 cycle)
G3NA-210B			0.1 to 10 A	0.1 to 4 A	150 A (60 Hz, 1 cycle)
G3NA-410B	200 to 480 VAC	180 to 528 VAC	0.2 to 10 A	0.2 to 4 A	220 A (60 Hz, 1 cycle)
G3NA-220B	24 to 240 VAC	19 to 264 VAC	0.1 to 20 A	0.1 to 4 A	
G3NA-420B	200 to 480 VAC	180 to 528 VAC	0.2 to 20 A	0.2 to 4 A	440 A (60 Hz, 1 cycle)
G3NA-240B	24 to 240 VAC	19 to 264 VAC	0.1 to 40 A	0.1 to 6 A	
G3NA-440B	200 to 480 VAC	180 to 528 VAC	0.2 to 40 A	0.2 to 6 A	
G3NA-450B	200 to 480 VAC	180 to 528 VAC	0.2 to 50 A	0.2 to 6 A	
G3NA-D210B	5 to 200 VDC	4 to 220 VDC	0.1 to 10 A	0.1 to 4 A	20 A (10 ms)

*When OMRON's heat sink (refer to the accessories) or a heat sink of specified size is used.

■ Characteristics

Item	G3NA-205B, -210B, -220B	G3NA-240B	G3NA-410B, -420B, -440B, -450B	G3NA-D210B
Operate time	1/2 of load power source cycle + 1 ms max. (DC input) 3/2 of load power source cycle + 1 ms max. (AC input)			1 ms max. (DC input) 30 ms max. (AC input)
Release time	1/2 of load power source cycle + 1 ms max. (DC input) 3/2 of load power source cycle + 1 ms max. (AC input)			5 ms max. (DC input) 30 ms max. (AC input)
Output ON voltage drop	1.6 V (RMS) max.		1.8 V (RMS) max.	1.5 V max.
Leakage current	5 mA max. (at 100 VAC) 10 mA max. (at 200 VAC)		10 mA max. (at 200 VAC) 20 mA max. (at 400 VAC)	5 mA max. (at 200 VDC)
Insulation resistance	100 MΩ min. (at 500 VDC)			
Dielectric strength	2,500 VAC, 50/60 Hz for 1 min			
Vibration resistance	Malfunction: 10 to 55 Hz, 1.5-mm double amplitude			
Shock resistance	Malfunction: 1,000 m/s ²			
Ambient temperature	Operating: -30°C to 80°C (with no icing or condensation) Storage: -30°C to 100°C (with no icing or condensation)			
Approved standards	UL508 File No.E64562/CSA C22.2 (No.0, No.14) File No.LR35535 TÜV R9151660 (EN60950)			
Ambient humidity	Operating: 45% to 85%			
Weight	Approx. 60 g	Approx. 70 g	Approx. 80 g	Approx. 70 g

Engineering Data

Load Current vs. Ambient Temperature Characteristics

G3NA-205B

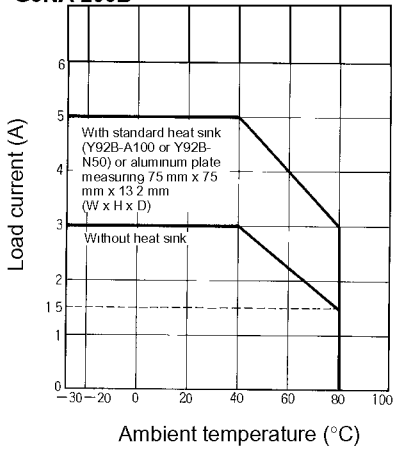

G3NA-210B/410B

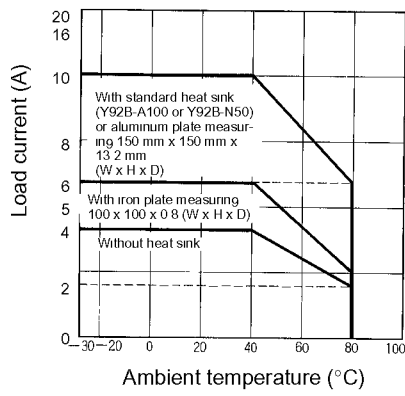

G3NA-220B/420B

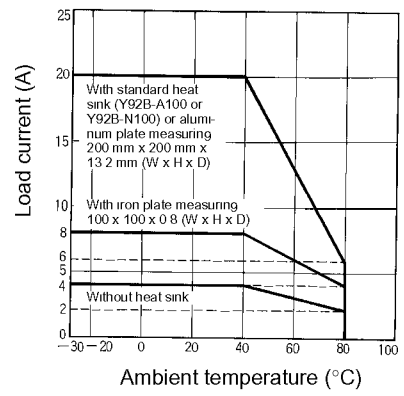

G3NA-240B

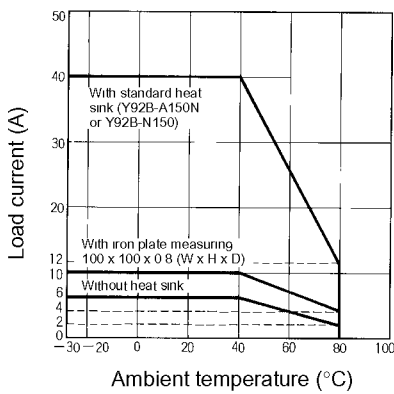

G3NA-440B

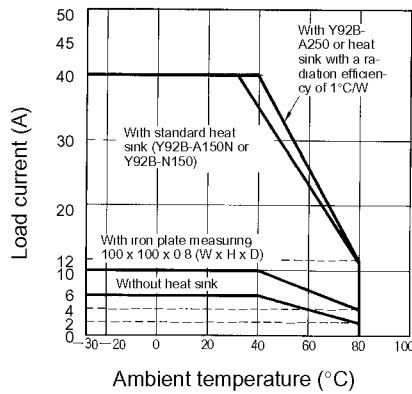

G3NA-D210B

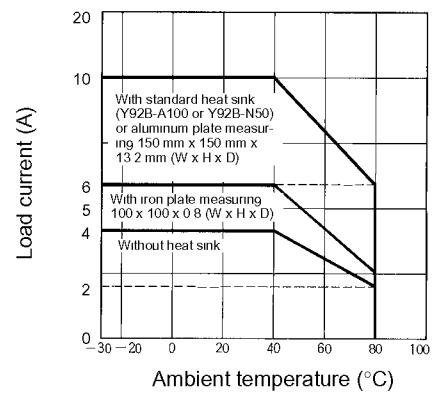

G3NA-450B

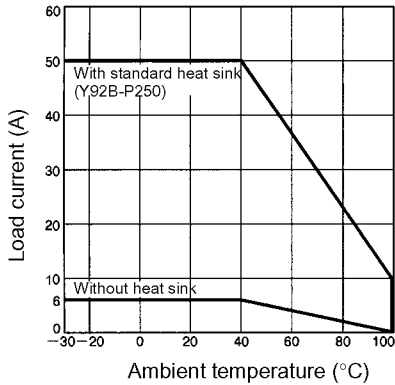

Inrush Current Resistivity

Non-repetitive (Keep the inrush current to half the rated value if it occurs repetitively.)

G3NA-205B

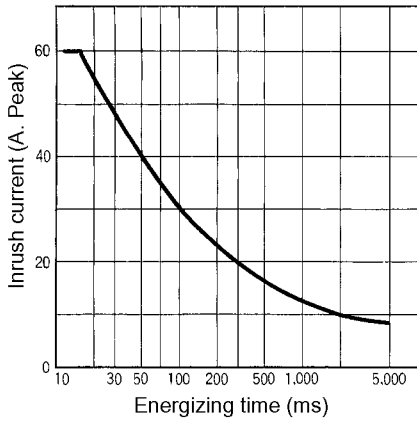

G3NA-210B/410B

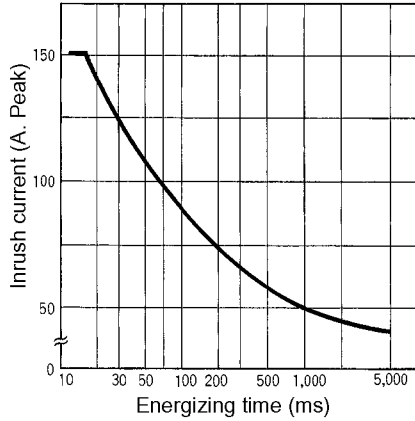

G3NA-220B/420B

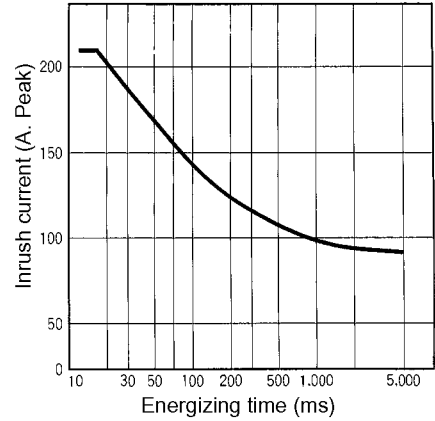

G3NA-240B/440B/450B

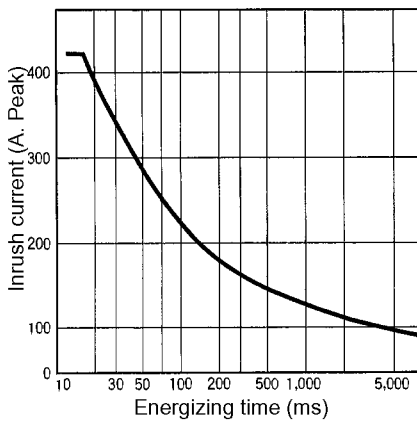

G3NA-D210B

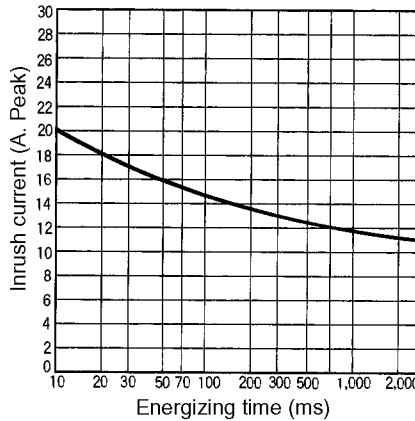

Temperature Characteristics (with Must Operate Voltage and Must Release Voltage)

G3NA-2□□B AC Input

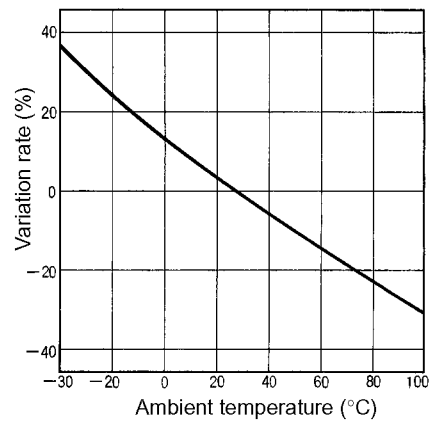

Heat Sink Size vs. Load Current

G3NA-220B

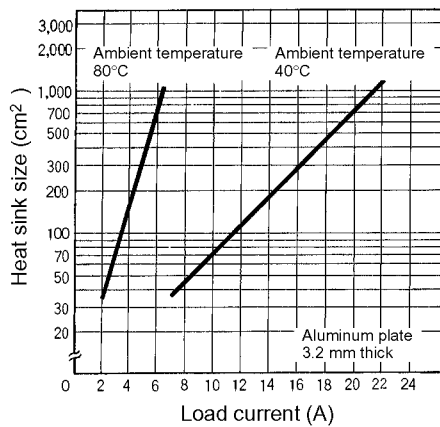

Note: The heat sink size refers to the combined area of the sides of the heat sink that radiate heat. For example, when a current of 18 A is allowed to flow through the SSR at 40°C, the graph shows that the heat sink size is about 450 cm². Therefore, if the heat sink is square, one side of the heat sink must be 15 cm (15² x 2 = 450) or longer.

Dimensions

Note: All units are in millimeters unless otherwise indicated.

In the case of surface mounting, a 30% derating of the load current is required.

The orientation indicated by the external dimensions is not the correct mounting orientation. When opening mounting holes, refer to the mounting hole dimensions.

G3NA-205B, G3NA-210B, G3NA-220B, G3NA-410B, G3NA-420B

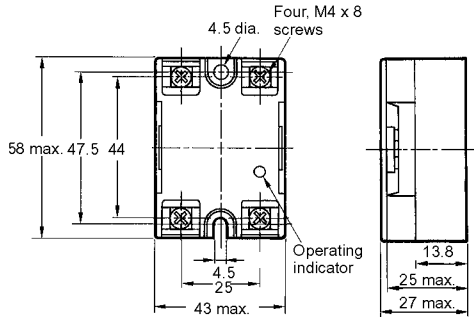
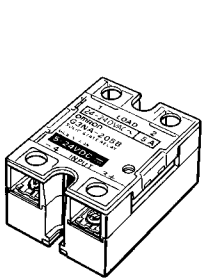

Mounting Holes

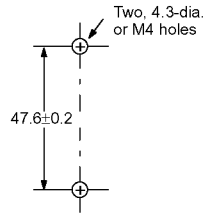

Terminal Arrangement/ Internal Connections (Top View)

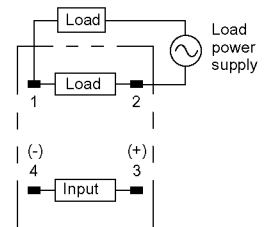

G3NA-240B, G3NA-440B, G3NA-450B

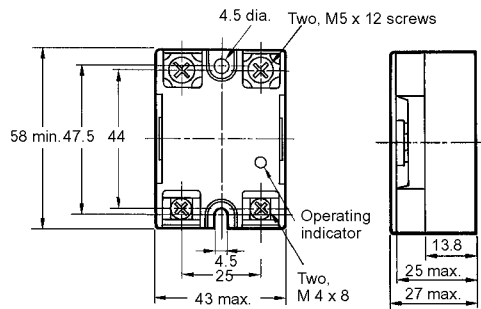
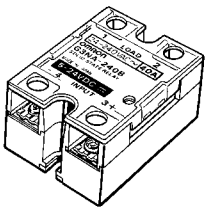

Mounting Holes

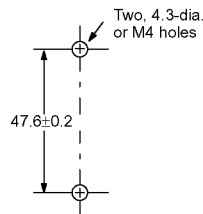

Terminal Arrangement/ Internal Connections (Top View)

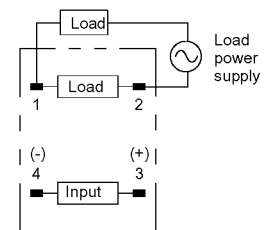

G3NA-D210B

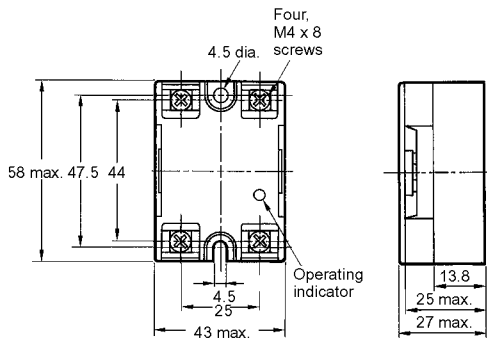
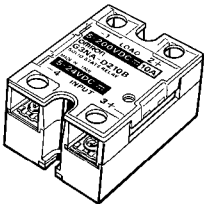

Mounting Holes

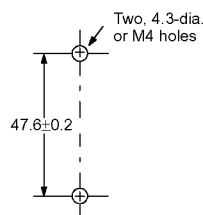

Terminal Arrangement/ Internal Connections (Top View)

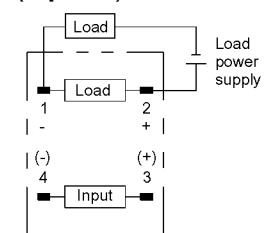

Heat Sink Y92B-N50

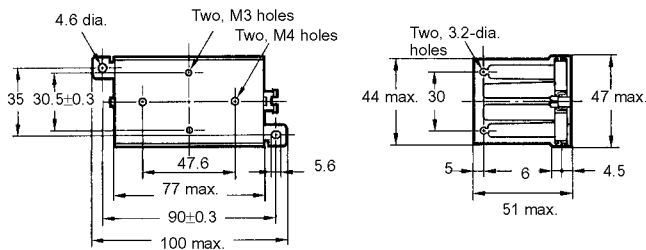
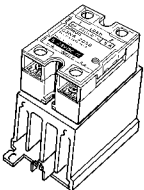

Mounting Holes

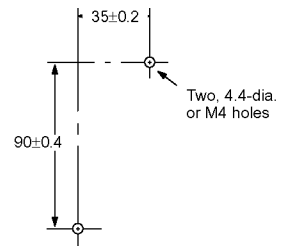

Weight: approx. 200 g

Y92B-N100

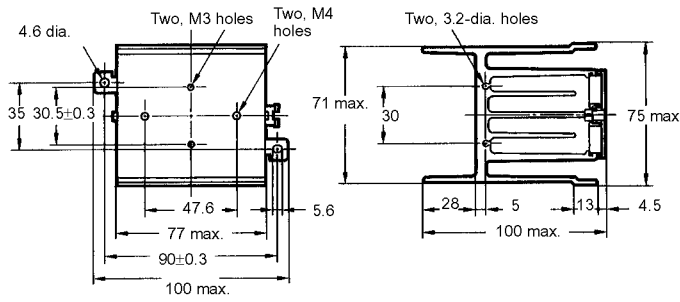
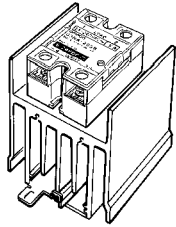

Mounting Holes

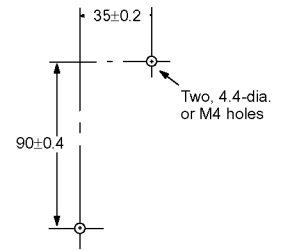

Weight: approx. 400 g

Y92B-N150

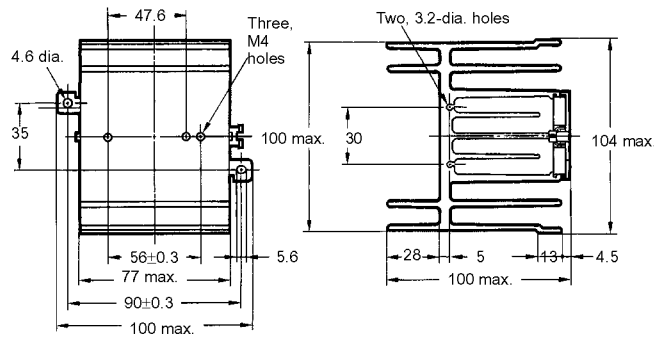
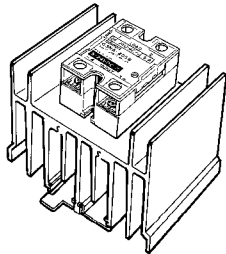

Mounting Holes

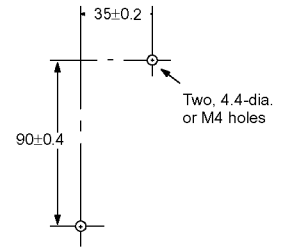

Weight: approx. 560 g

Y92B-A100

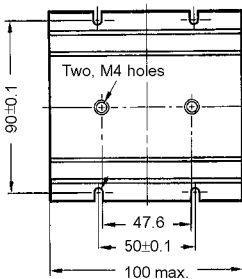

Y92B-A150N

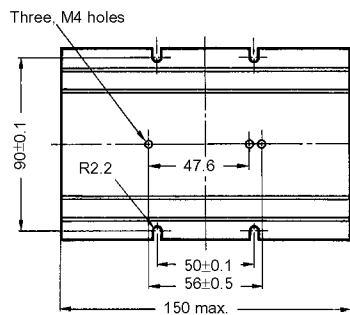

Y92B-A250

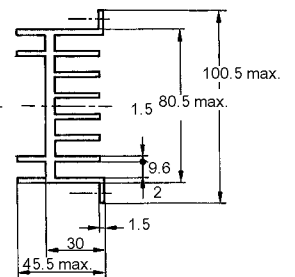
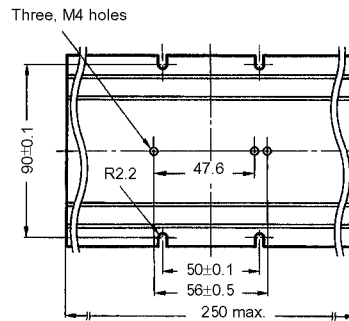

Mounting Holes
Y92B-A100
Y92B-A150
Y92B-A250

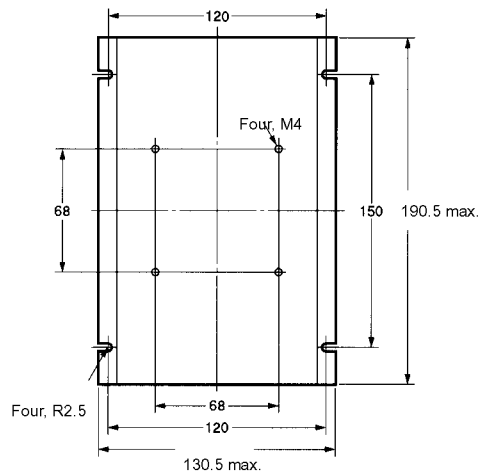
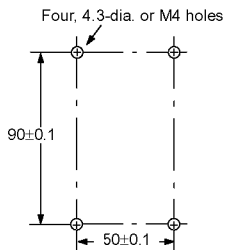

Mounting Holes

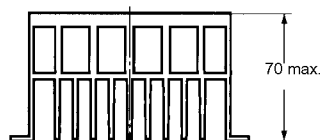
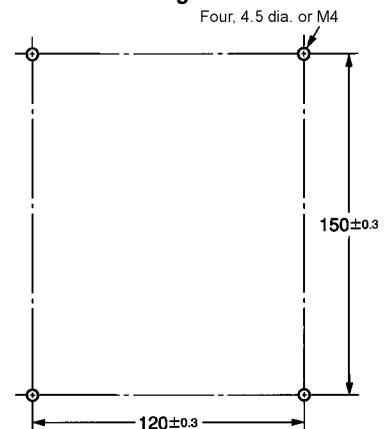

R99-11

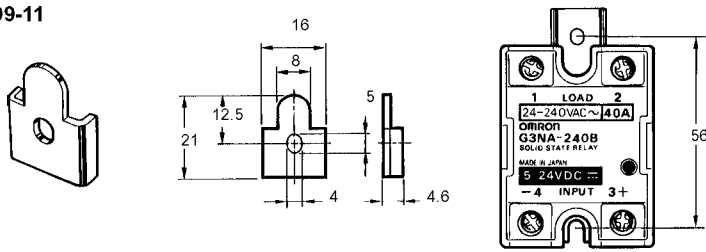

Use Mounting Bracket R99-11 so that the G3NA-240B can be mounted with the same pitch as that of the G3N-240B.

Precautions

Refer to pages 11 to 19 for general precautions.

Load Connection

For an AC load, use a power supply rated at 50 or 60 Hz. The maximum operating frequency is 10 Hz. The G3NA has a built-in varistor for overvoltage protection.

Zero Cross Function

An SSR with a zero cross function operates when an AC load voltage reaches the zero point or its vicinity. This reduces clicking noises when the load is input, and minimizes the influence of an inductive load, such as a lamp, heater, or motor, on the power supply because the inrush current of the load is reduced. This can also minimize the scale of the inrush current protection circuit.

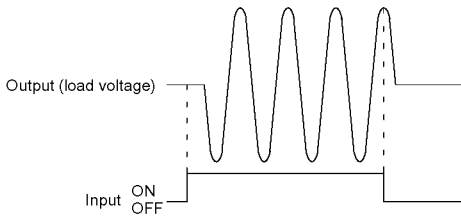

At a low applied voltage, such as 24 VAC, the load current is not fully supplied. When the Unit is switched ON, the voltage required to power the Unit deprives the output signal of the necessary voltage level and thus creates loss time. The lower the load voltage is, the greater the loss time is. This condition, however, will not create any serious problems.

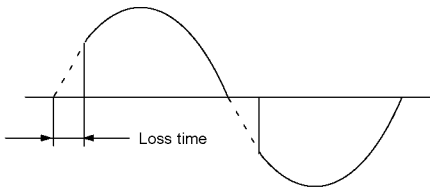

For a DC or L load, a diode should be connected in parallel the load to absorb the counter electromotive force of the load.

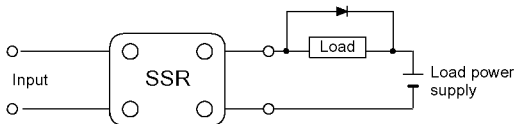

When attaching a heat sink to the G3NA, apply Silicone Grease or equivalent heat conductive grease on the heat sink. (Toshiba Silicon, Shinetsu Silicon, etc.)

Tighten the mounting screws of the heat sink with a torque of 0.78 to 0.98 N • m.

EN55011 Measurement of Mains Terminal Disturbance Voltage

The G3NA-UTU conforms to EN55011 standards when a capacitor is connected to the load power supply as shown in the following circuit diagram.

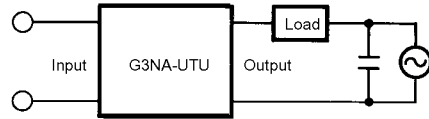

Recommended Capacitor:
Nissei Denki's MKT-series R40 (1 μF)

The output terminal side of the G3NA-D210B is connected to a built-in diode for protecting the SSR from damage that may result from reverse connection. The SSR, however, cannot withstand one minute or more if the wires are connected in reverse order. Therefore, pay the utmost attention not to make polarity mistakes on the load side.

ALL DIMENSIONS SHOWN ARE IN MILLIMETERS.

To convert millimeters into inches, multiply by 0.03937. To convert grams into ounces, multiply by 0.03527.

Power Solid-state Relay

G3PA-(VD)

Extremely Thin Relays Integrated with Heat Sink

- Downsizing achieved through optimum design of heat sink.
- Mounting possible via screws or via DIN rail.
- Dense mounting possible for linking terminals. (Except for G3PA-260B-VD.)
- Applicable with 3-phase loads.
- Replaceable power element cartridges.
- Conforms to VDE 0160 (finger protection), with a dielectric strength of 4,000 V between input and load.
- Conforms to VDE 0805, IEC 950.
- Approved by UL CSA and VDE.



Ordering Information

Model	Isolation	Zero cross function	Indicator	Applicable output load	Rated input voltage
G3PA-210B-VD	Phototriac coupler	Yes	Yes	10 A at 24 to 240 VAC	5 to 24 VDC
G3PA-220B-VD				20 A at 24 to 240 VAC	
G3PA-240B-VD				40 A at 24 to 240 VAC	
G3PA-260B-VD				60 A at 24 to 240 VAC	
G3PA-210BL-VD	No	No	No	10 A at 24 to 240 VAC	
G3PA-220BL-VD				20 A at 24 to 240 VAC	
G3PA-240BL-VD				40 A at 24 to 240 VAC	
G3PA-260BL-VD				60 A at 24 to 240 VAC	
G3PA-210B-VD		Yes		10 A at 24 to 240 VAC	24 VAC
G3PA-220B-VD				20 A at 24 to 240 VAC	
G3PA-240B-VD				40 A at 24 to 240 VAC	
G3PA-260B-VD				60 A at 24 to 240 VAC	
G3PA-420B-VD				20 A at 180 to 400 VAC	12 to 24 VDC
G3PA-430B-VD				30 A at 180 to 400 VAC	
G3PA-420B-VD-2				20 A at 200 to 480 VAC	
G3PA-430B-VD-2				30 A at 200 to 480 VAC	
G3PA-450B-VD-2				50 A at 200 to 480 VAC	

Replacement Parts

Name	Carry current	Model	Applicable SSR
Power Device Cartridge	10 A	G32A-A10-VD DC5-24	G3PA-210B-VD DC5-24
		G32A-A10L-VD DC5-24	G3PA-210BL-VD DC5-24
		G32A-A10-VD AC24	G3PA-210B-VD AC24
	20 A	G32A-A20-VD DC5-24	G3PA-220B-VD DC5-24
		G32A-A20L-VD DC5-24	G3PA-220BL-VD DC5-24
		G32A-A20-VD AC24	G3PA-220B-VD AC24
	40 A	G32A-A40-VD DC5-24	G3PA-240B-VD DC5-24
		G32A-A40L-VD DC5-24	G3PA-240BL-VD DC5-24
		G32A-A40-VD AC24	G3PA-240B-VD AC24
	60 A	G32A-A60-VD DC5-24	G3PA-260B-VD DC5-24
		G32A-A60L-VD DC5-24	G3PA-260BL-VD DC5-24
		G32A-A60-VD AC24	G3PA-260B-VD AC24
	20 A	G32A-A420-VD DC12-24	G3PA-420B-VD DC12-24
	30 A	G32A-A430-VD DC12-24	G3PA-430B-VD DC12-24
20 A	G32A-A420-VD-2 DC12-24	G3PA-420B-VD-2 DC12-24	
30 A	G32A-A430-VD-2 DC12-24	G3PA-430B-VD-2 DC12-24	
50 A	G32A-A450-VD-2 DC12-24	G3PA-450B-VD-2 DC12-24	

Specifications

■ Ratings (at 25°C)

Input

Model	Rated voltage	Voltage range	Input current impedance	Voltage level	
				Must operate voltage	Must release voltage
G3PA-210B-VD	5 to 24 VDC	4 to 30 VDC	7 mA max.	4 VDC max.	1 VDC min.
G3PA-220B-VD					
G3PA-240B-VD					
G3PA-260B-VD					
G3PA-210BL-VD	5 to 24 VDC	4 to 30 VDC	20 mA max.	4 VDC max.	1 VDC min.
G3PA-220BL-VD					
G3PA-240BL-VD					
G3PA-260BL-VD					
G3PA-210B-VD	24 VAC	19.2 to 26.4 VAC	1.4 kΩ±20%	19.2 VAC max.	4.8 VAC min.
G3PA-220B-VD					
G3PA-240B-VD					
G3PA-260B-VD					
G3PA-420B-VD	12 to 24 VDC	9.6 to 30 VDC	7 mA max.	9.6 VDC max.	1 VDC min.
G3PA-430B-VD					
G3PA-420B-VD-2					
G3PA-430B-VD-2					
G3PA-450B-VD-2					

Output

Model	Applicable load		
	Load voltage	Load current	Inrush current
G3PA-210B(L)-VD	19 to 264 VAC (50/60 Hz)	0.1 to 10 A	150 A (60 Hz, 1 cycle)
G3PA-220B(L)-VD		0.1 to 20 A	220 A (60 Hz, 1 cycle)
G3PA-240B(L)-VD		0.5 to 40 A	440 A (60 Hz, 1 cycle)
G3PA-260B(L)-VD		0.5 to 60 A	440 A (60 Hz, 1 cycle)
G3PA-420B-VD	150 to 440 VAC (50/60 Hz)	0.5 to 20 A	220 A (60 Hz, 1 cycle)
G3PA-430B-VD		0.5 to 30 A	440 A (60 Hz, 1 cycle)
G3PA-420B-VD-2	180 to 528 VAC (50/60 Hz)	0.5 to 20 A	220 A (60 Hz, 1 cycle)
G3PA-430B-VD-2		0.5 to 30 A	440 A (60 Hz, 1 cycle)
G3PA-450B-VD-2		0.5 to 50 A	440 A (60 Hz, 1 cycle)

Refer to *Engineering Data* for further details.

■ Characteristics

Item	G3PA-210B(L)-VD	G3PA-220B(L)-VD	G3PA-240B(L)-VD	G3PA-260B(L)-VD	G3PA-420B-VD	G3PA-420B-VD-2	G3PA-430B-VD	G3PA-430B-VD-2	G3PA-450B-VD-2
Operate time	1/2 of load power source cycle + 1 ms max. (DC Input, -B models) 1 1/2 of load power source cycle + 1 ms max. (AC Input) 1 ms max. (-BL models)								
Release time	1/2 of load power source cycle + 1 ms max. (DC Input) 1 1/2 of load power source cycle + 1 ms max. (AC Input)								
Output ON voltage drop	1.6 V (RMS) max.				1.8 V (RMS) max.				
Leakage current	5 mA max. (at 120 VAC) 10 mA max. (at 230 VAC)		10 mA max. (at 120 VAC) 20 mA max. (at 230 VAC)		20 mA max. (at 400 VAC)				
I ² t	260 A ² S		810 A ² S		260 A ² S		810 A ² S		810 A ² S
Insulation resistance	100 MΩ min. (at 500 VDC)								
Dielectric strength	4,000 VAC, 50/60 Hz for 1 min								
Vibration resistance	Malfunction: 10 to 55 Hz, 0.75-mm double amplitude (mounted to DIN rail)								
Shock resistance	Malfunction: 300 m/s ² (mounted to DIN rail)								
Ambient temperature	Operating: -30°C to 80°C (with no icing or condensation) Storage: -30°C to 100°C (with no icing or condensation)								
Approved standards	UL508 File No.E64562, CSA C22.2 (No.14, No.950) File No.LR35535, EN60950 File No. 5915UG						Approval expected in Mar 2000		
Ambient humidity	Operating: 45% to 85%								
Weight	Approx. 260 g	Approx. 340 g	Approx. 460 g	Approx. 900 g	Approx. 290 g	Approx. 290 g	Approx. 410 g	Approx. 410 g	Approx. 900 g

Engineering Data

Load Current vs. Ambient Temperature Characteristics

Horizontal Mounting to Ground

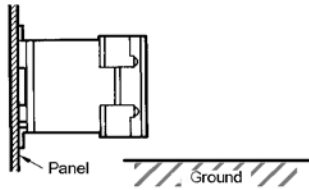

G3PA-210B(L)-VD, G3PA-220B(L)-VD

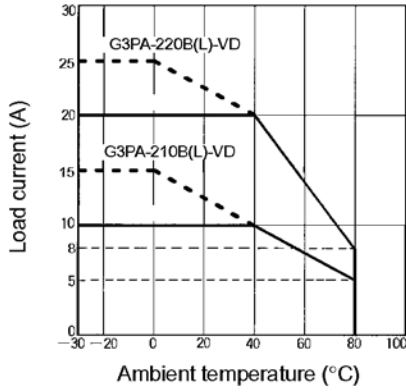

G3PA-240B(L)-VD

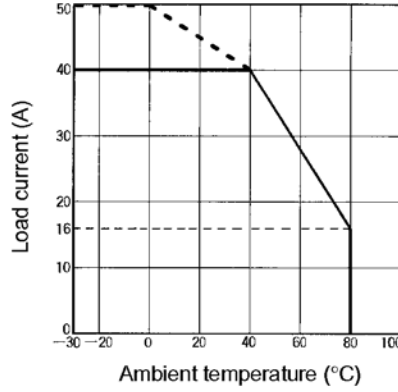

G3PA-260B(L)-VD

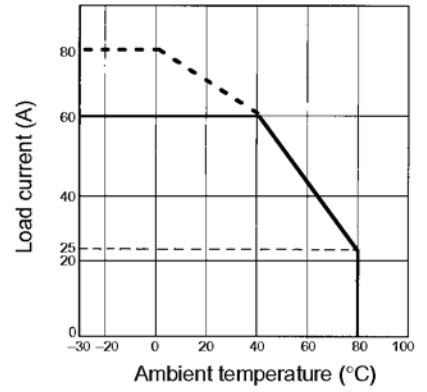

G3PA-420B-VD, G3PA-420B-VD-2

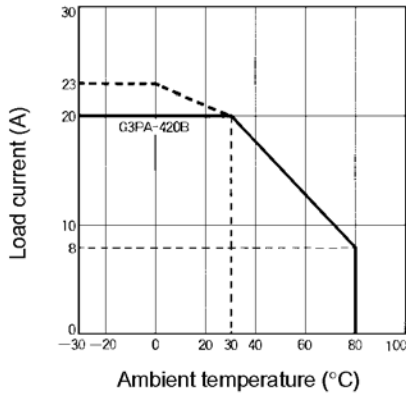

G3PA-430B-VD, G3PA-430B-VD-2

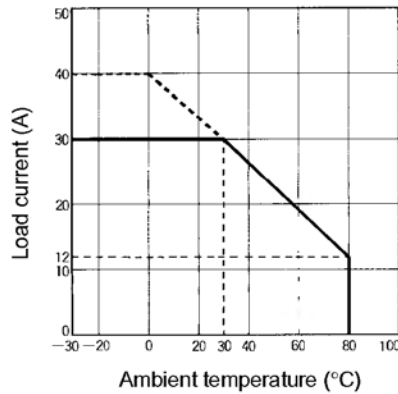

G3PA-450B-VD-2

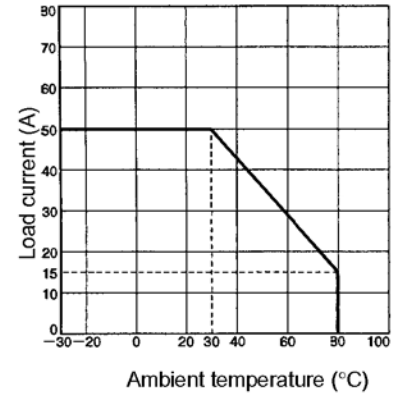

Note: Dense mounting is possible for a maximum of three Units by reducing the load current by 20%. (A minimum clearance of 10 mm must be provided when mounting four or more Units.)

Characteristics Between Input Voltage and Input Current

G3PA-2□0B-VD

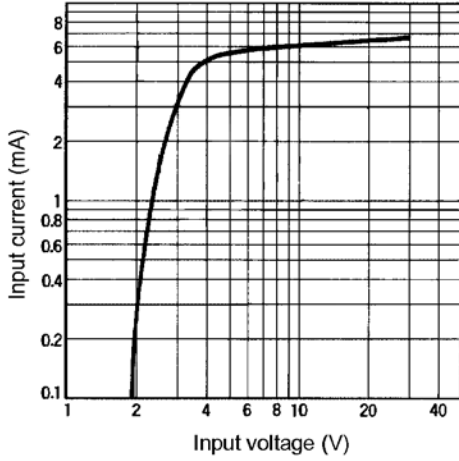

G3PA-4□B-VD

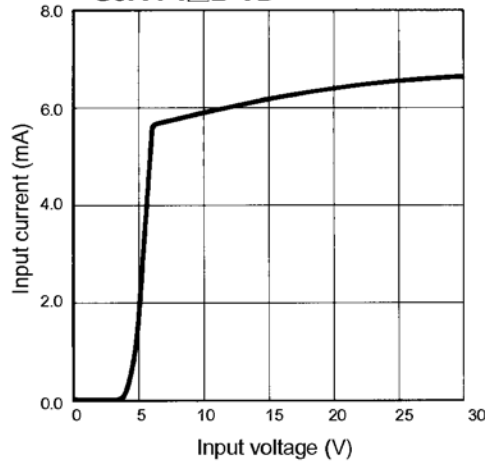

Vertical Mounting to Ground

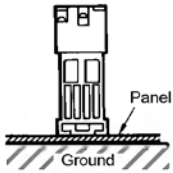

G3PA-210B(L)-VD, G3PA-220B(L)-VD

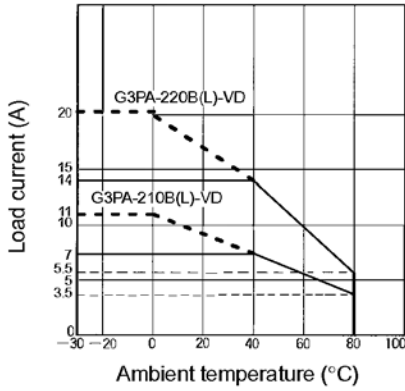

G3PA-240B(L)-VD

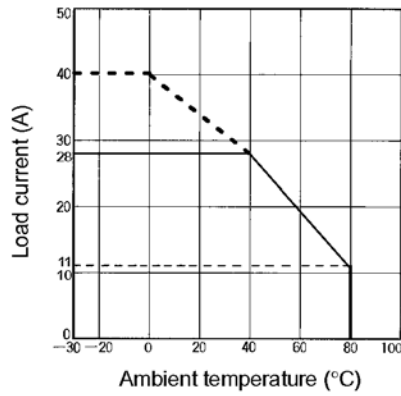

G3PA-260B(L)-VD

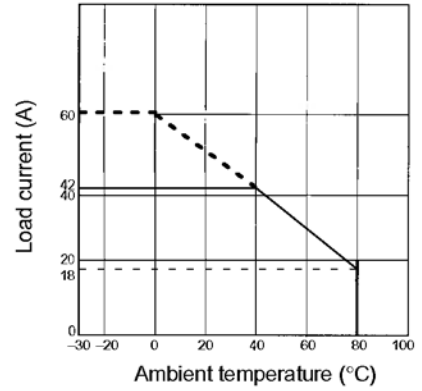

**G3PA-420B-VD, G3PA-430B-VD
G3PA-420B-VD-2, G3PA-430B-VD-2**

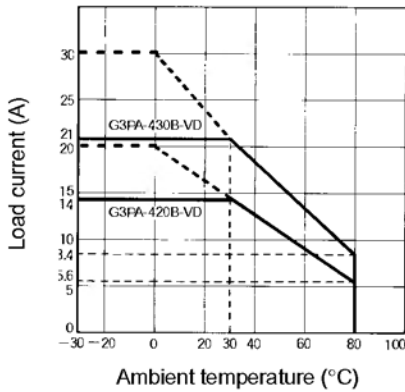

G3PA-450B-VD-2

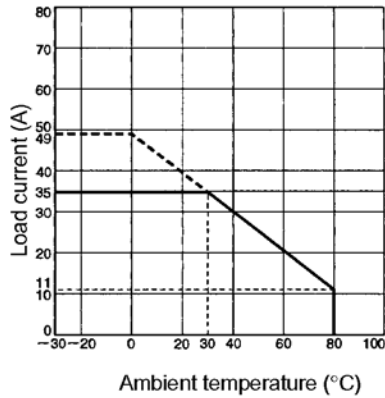

Dense Mounting Side-by-side (Up to Three)

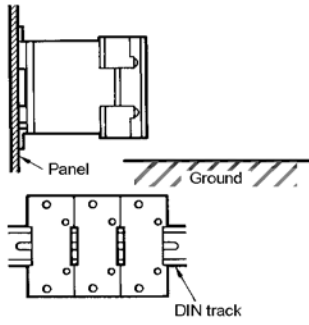

G3PA-210B(L)-VD, G3PA-220B(L)-VD

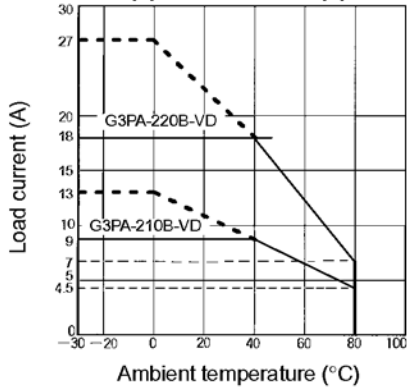

G3PA-240B(L)-VD

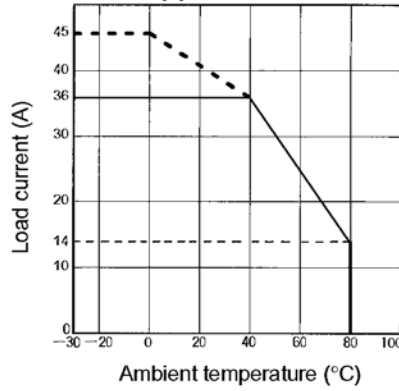

G3PA-260B(L)-VD

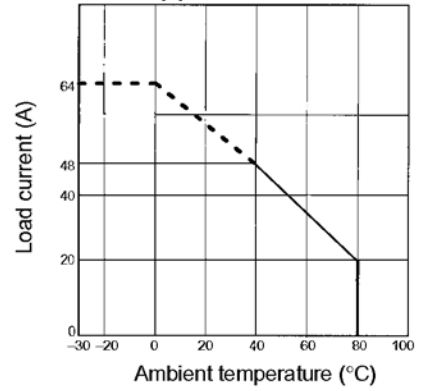

G3PA-420B-VD, G3PA-420B-VD-2

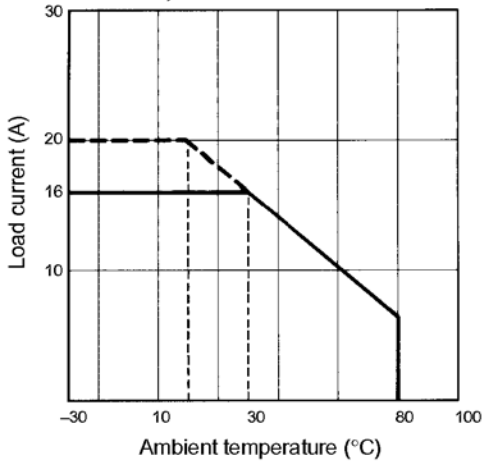

G3PA-430B-VD, G3PA-430B-VD-2

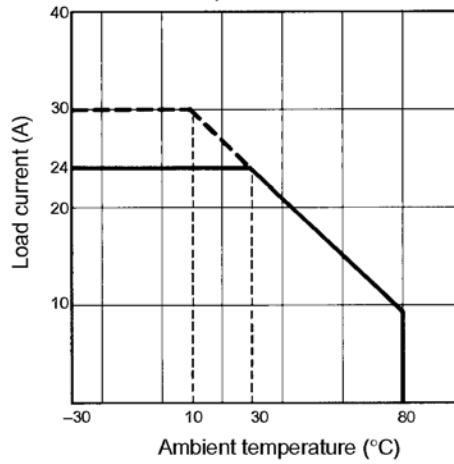

G3PA-450B-VD-2

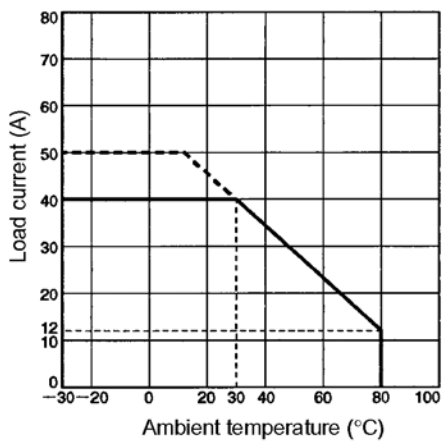

Inrush Current Resistivity

Non-repetitive (Keep the inrush current to half the rated value if it occurs repetitively.)

G3PA-210B(L)-VD

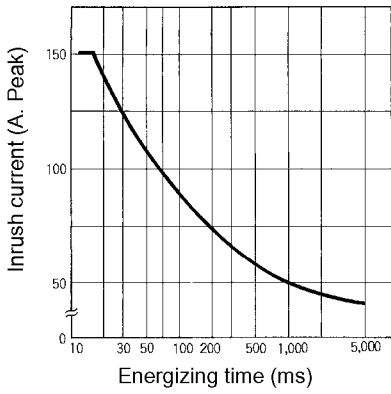

G3PA-220B(L)-VD

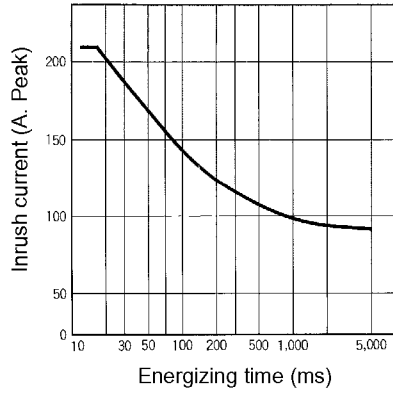

G3PA-240B(L)-VD/260B(L)-VD

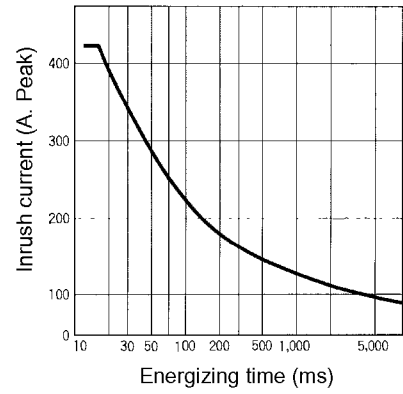

G3PA-420B-VD, G3PA-420B-VD-2

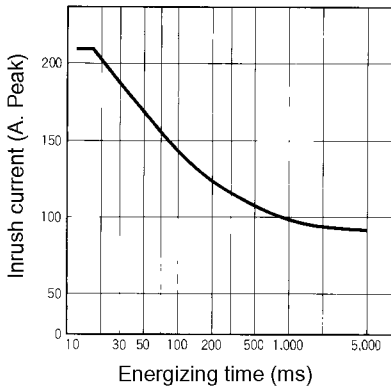

G3PA-430B-VD, G3PA-430B-VD-2, G3PA-450B-VD-2

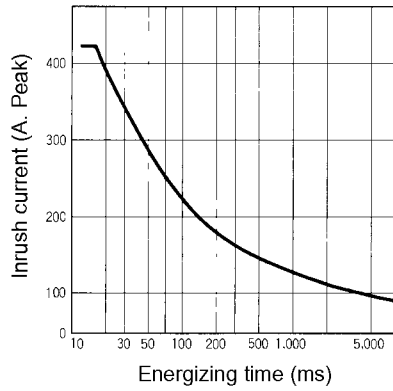

Nomenclature

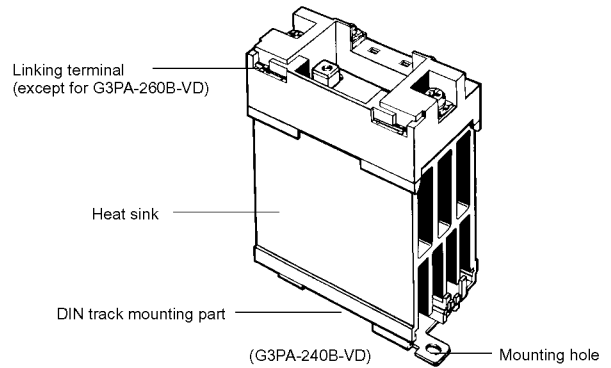
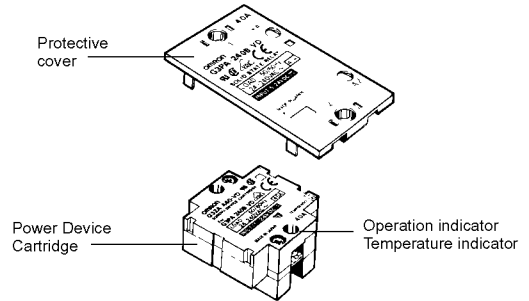
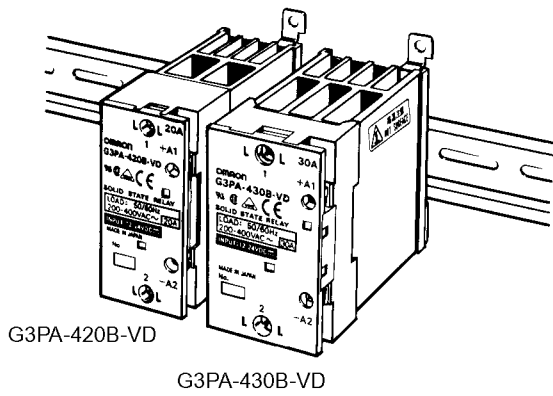
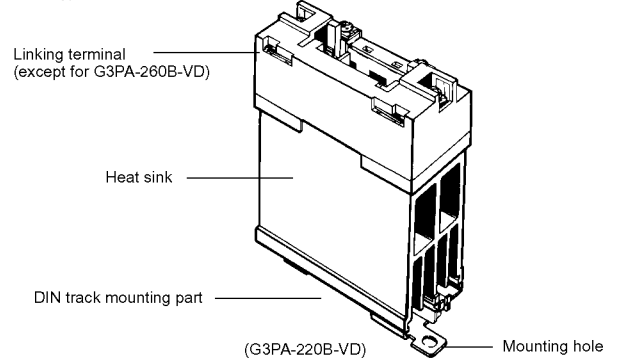
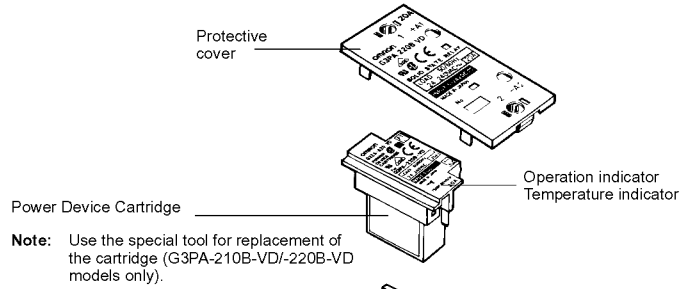
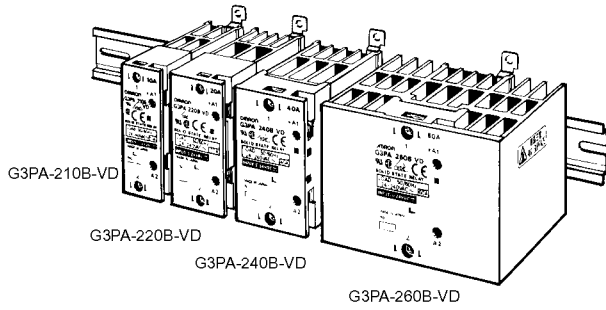

Operation

■ Renewal Parts

G32A-A Power Device Cartridge

The G32A-A Power Device Cartridge (a Triac Unit) can be replaced with a new one. When the temperature indicator has changed from pink to red, the triac circuitry may have malfunctioned possibly by an excessive flow of current, in which case, dismount the damaged cartridge for replacement.

The damaged cartridge can be replaced with a new one without disconnecting the wires from the G3PA.

Improve the heat radiation efficiency of the G3PA before replacing the cartridge.

The G32A-A Power Device Cartridge can withstand an excessive current for a short period time, such as may be caused accidentally by the short circuitry of the load, in which case the temperature indicator will not turn red.

Appearance

G32A-A10-VD

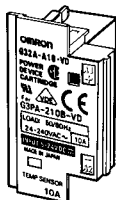

G32A-A20-VD

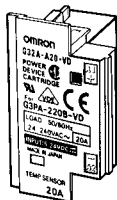

G32A-A40-VD

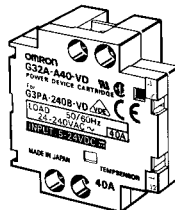

G32A-A60-VD

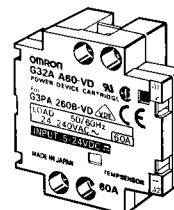

G32A-A420-VD

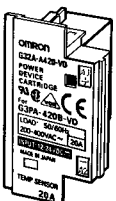

G32A-A430-VD

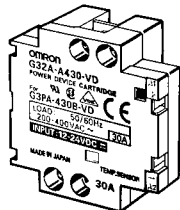

Replacement

Note: Be sure to turn OFF the power supply when replacing the Cartridge. Supplying power with the Cartridge removed may result in malfunction.

G32A-A10-VD/G32A-A20-VD/G32-A420-VD

Use the special tool (provided) to extract the cartridge for replacement with a new one.

Extraction

Follow the procedures below to dismount the G32A-A Power Device Cartridge from the G3PA.

1. **Switch off the power.**
2. Remove the terminal cover.
3. Hook the indented part of the cartridge with the tool and pull up on the cartridge to remove it.

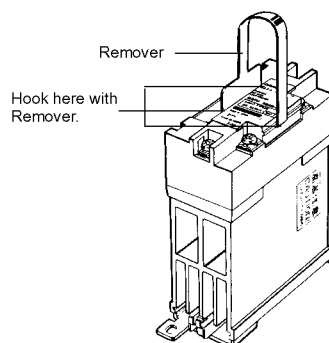

Mounting

Follow the procedures below to mount the G32A-A Power Device Cartridge on the G3PA.

1. Apply silicone grease (provided with the G32A-A) to the entire surface of the heat radiator.

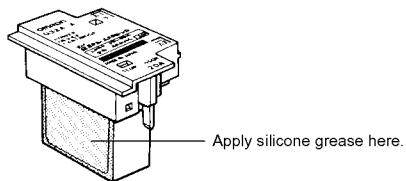

2. Make sure that there is no dust or pieces of wire on the heat radiator of the G32A-A or the G3PA.

3. Insert the cartridge into the opening of the G3PA so that the letters on the cartridge and those on the G3PA are in the same direction and side A and side B are even.

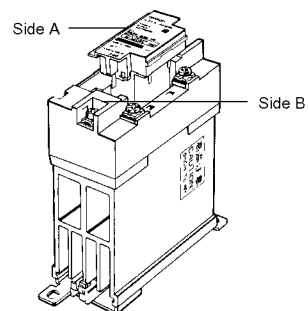

4. Attach the terminal cover.
5. Switch on the power and check the G3PA to be sure it works properly.

G32A-A40-VD/G32A-A60-VD/G32A-A430-VD

The G32A Power Device Cartridge is mounted and secured with screws to the G3PA Unit.

Extraction

Follow the procedures below to dismount the G32A-A Power Device Cartridge from the G3PA.

1. **Switch off the power.**
2. Remove the terminal cover.
3. Loosen the two centered screws on the sides to dismount the cartridge. The screws are connected to terminals 1 and 2.

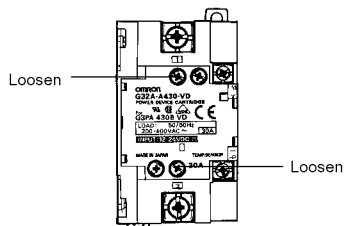

4. Loosen the screws on both the corners.

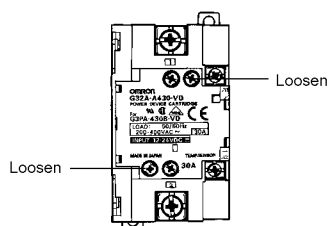

5. Hold the indented part of both the corners to dismount the cartridge.

Mounting

1. Apply silicone grease to the entire surface of the heat radiator.

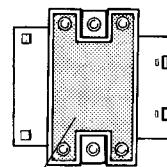

Apply silicone grease here.

2. Make sure that there is no dust or pieces of wire on the radiator of the G32A-A or the G3PA.
3. Insert the cartridge into the opening of the G3PA so that side A and side B are even.

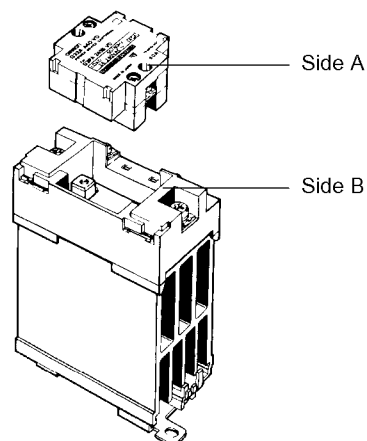

4. Tighten the screws on both the corners with a tightening torque of 0.59 to 0.78 N • m.
5. Tighten the screws on both the sides with a tightening torque of 0.59 to 0.78 N • m.
6. Attach the terminal cover.
7. Switch on the power and check the G3PA to be sure it works properly.

■ Linking Terminal Connection

- Connecting with linking terminal for G3PA-210B-VD, -220B-VD, -240B-VD and G3PA-420B-VD, G3PA-430B-VD.

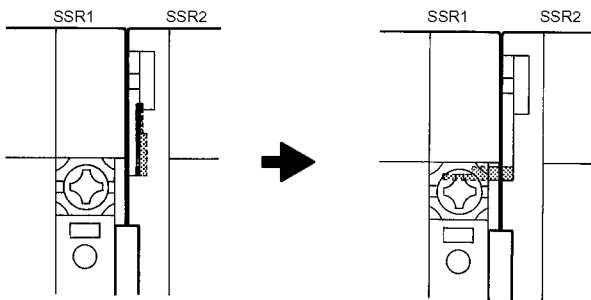

1. When SSRs are densely mounted side-by-side, loosen the M3.5 Sems screw and flip the linking terminal down.
2. Insert the linking terminal securely into the center of the screw and tighten the screw.

- Connecting with linking terminal for G32A.

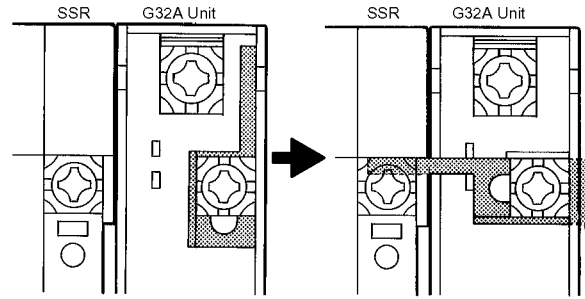

1. When SSR are densely mounted side-by-side, loosen the M3.5 Sems screw on the G32A and flip the linking terminal down.
2. Insert the linking terminal securely into the center of the screw and tighten the screw. Ensure that the linking terminal does not protrude.

* The cover will not fit if the terminal protrudes.

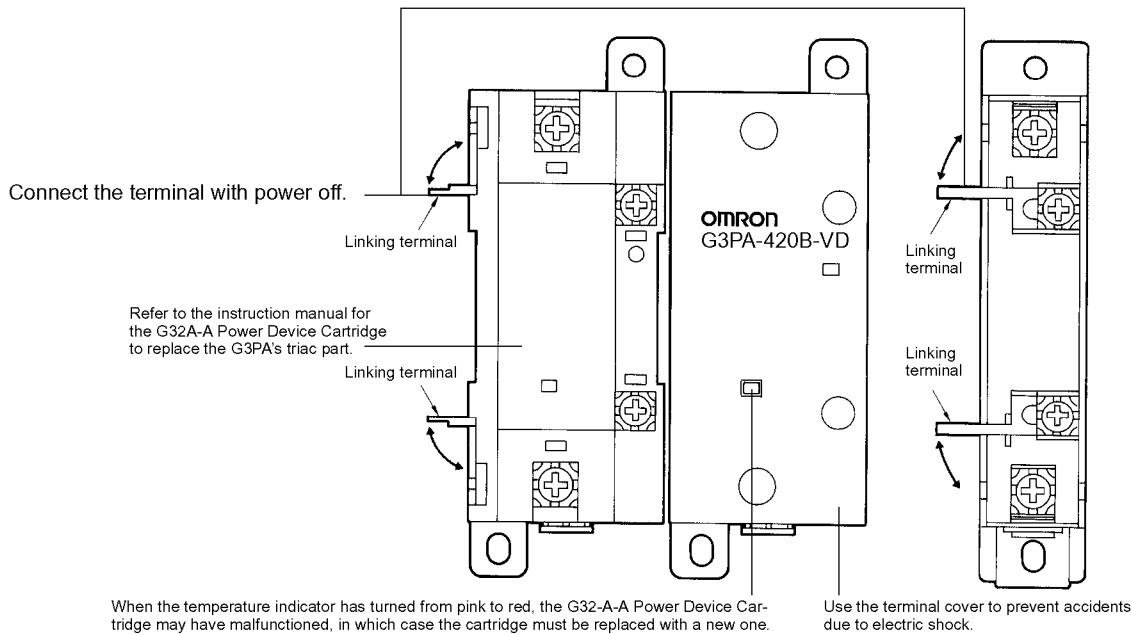

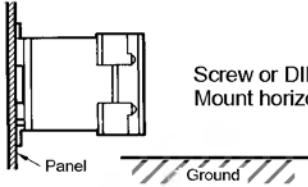
Horizontal Mounting

Screw or DIN track mounting is possible.
Mount horizontally to ground.

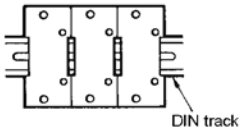
Dense Mounting

Dense mounting side-by-side up to three G3PA SSRs is possible.
Load current should be reduced by 10% for G3PA-210B-VD, -220B-VD, -240B-VD, and by 20% for other models.
To mount more than three G3PA SSRs densely side-by-side, keep a distance of 10 mm between each SSR.

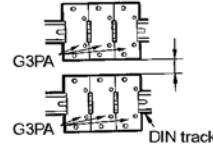

Keep a distance of 80 mm between the upper SSR and the lower SSR.

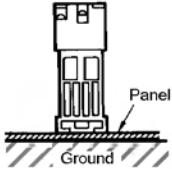
Vertical Mounting

For vertical mounting, the load current must be 30% lower than the rated one (refer to *Engineering Data*).

At a rated ambient temperature for each.

Note: Keep a distance of 3 cm or more between the G3PA (especially the SSR on the upper side) and the duct.

Dimensions

Note: All units are in millimeters unless otherwise indicated.

G3PA-210B-VD

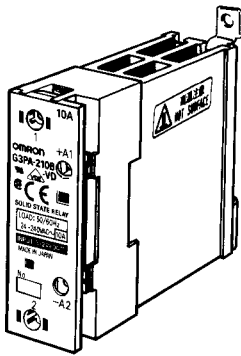

Without Terminal Cover

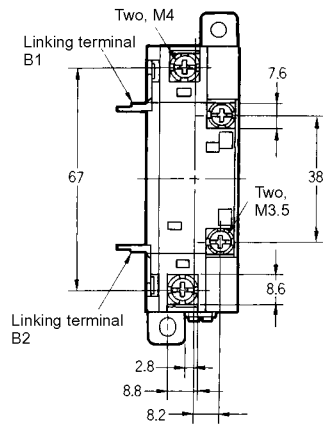

With Terminal Cover

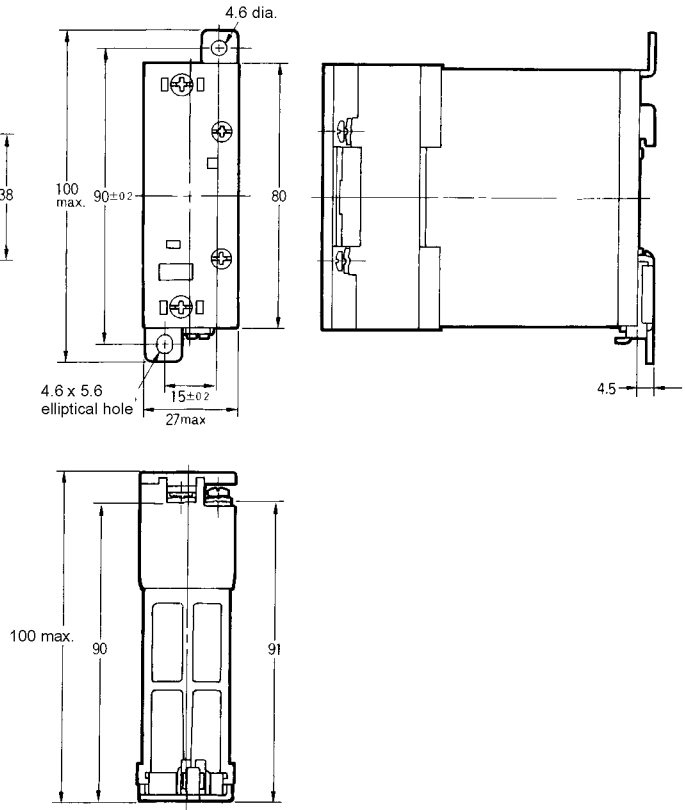

Mounting Holes

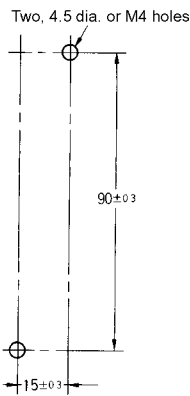

**Terminal Arrangement/
Internal Connections**

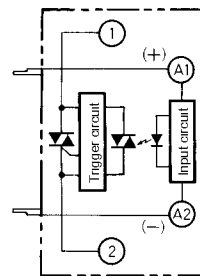

G3PA-220B-VD

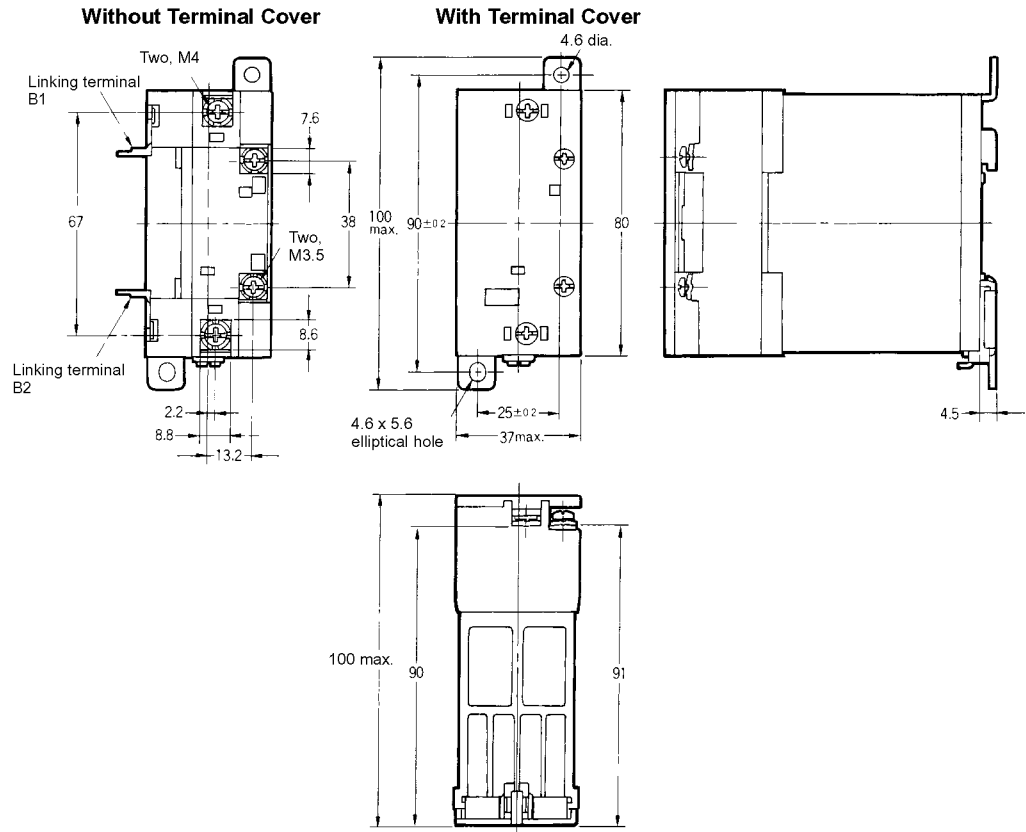
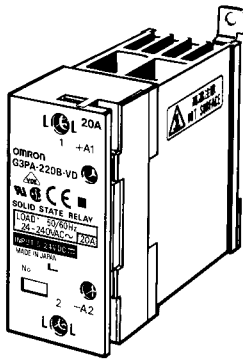

Mounting Holes

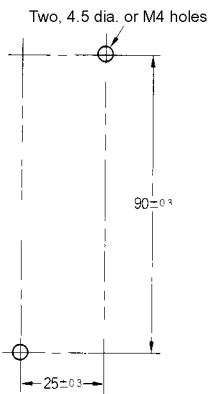

Terminal Arrangement/ Internal Connections

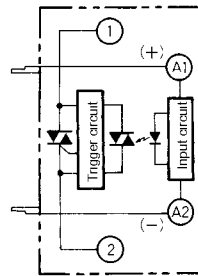

G3PA-240B-VD

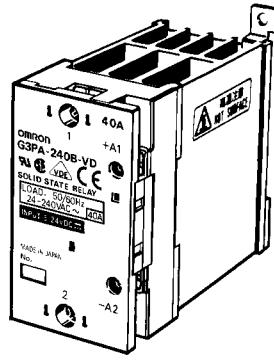

Without Terminal Cover

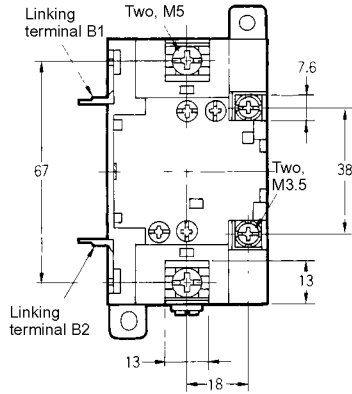

With Terminal Cover

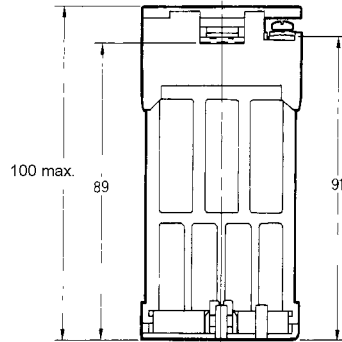
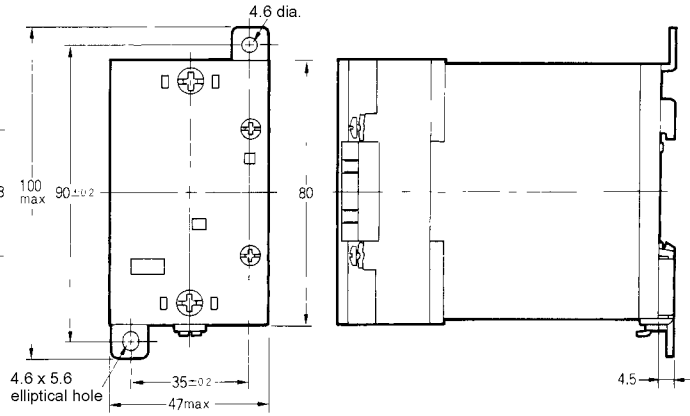

Mounting Holes

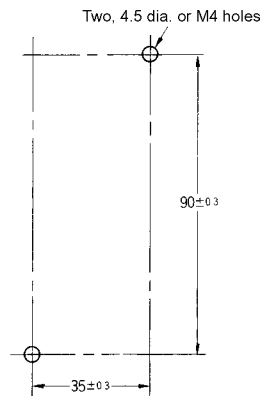

Terminal Arrangement/
Internal Connections

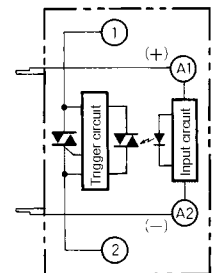

G3PA-260B-VD
G3PA-450B-VD-2

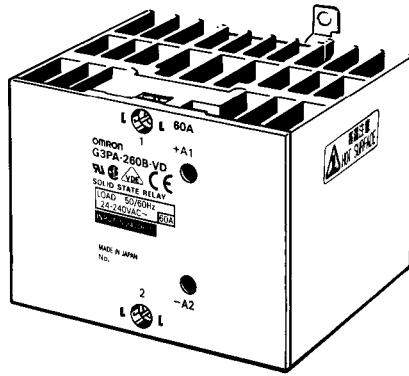

Without Terminal Cover

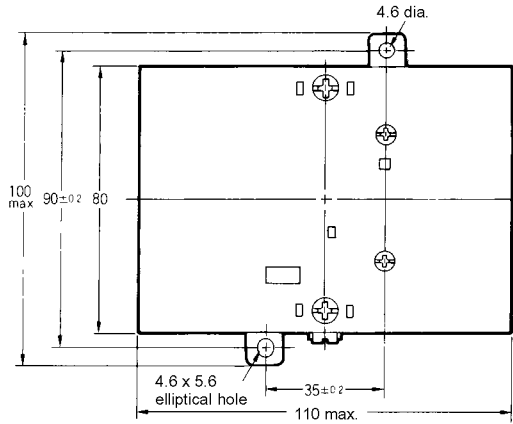

With Terminal Cover

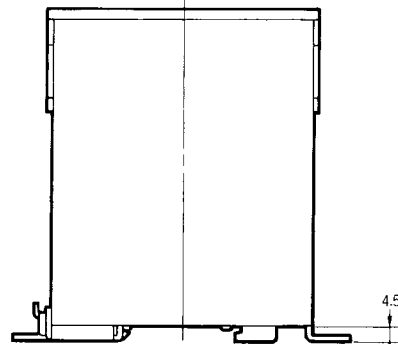
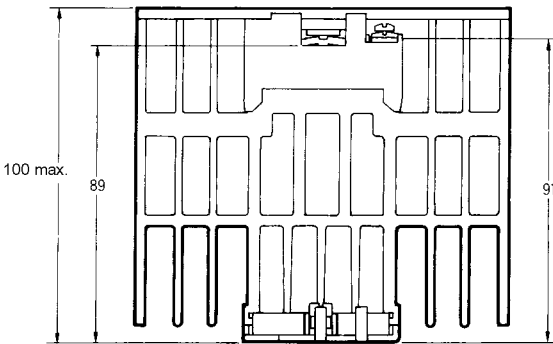
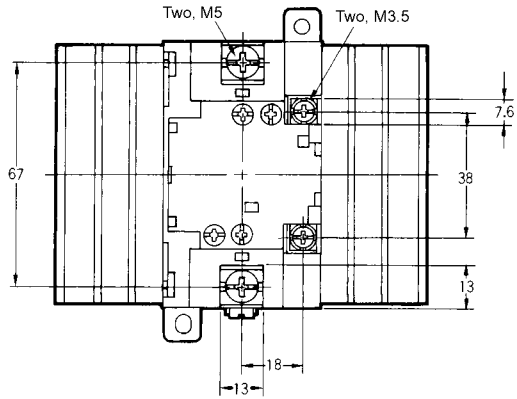

Mounting Holes

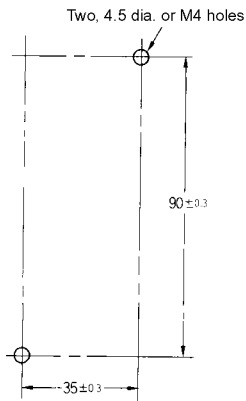

Terminal Arrangement/
Internal Connections

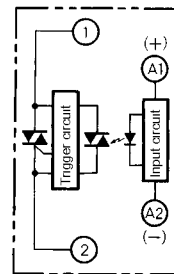

G3PA-420B-VD, G3PA-420B-VD-2

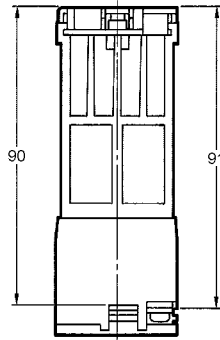
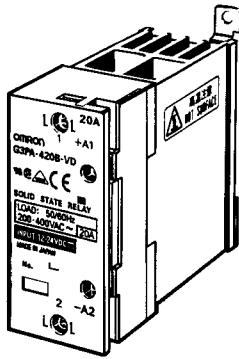

Terminal Arrangement/
Internal Connections

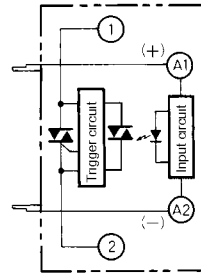

Mounting Holes

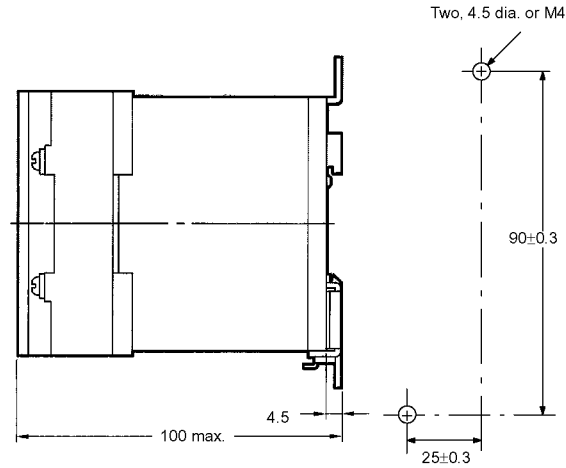
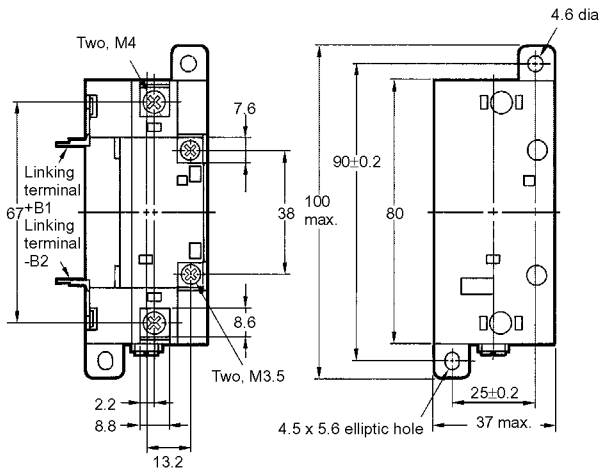

G3PA-430B-VD, G3PA-430B-VD-2

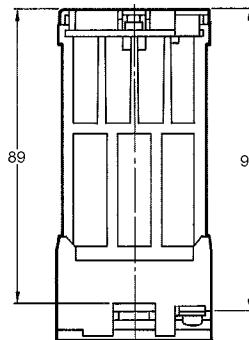
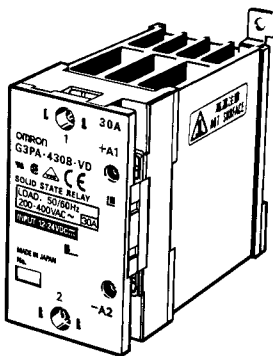

Terminal Arrangement/
Internal Connections

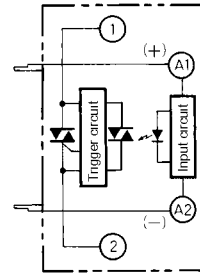

Mounting Holes

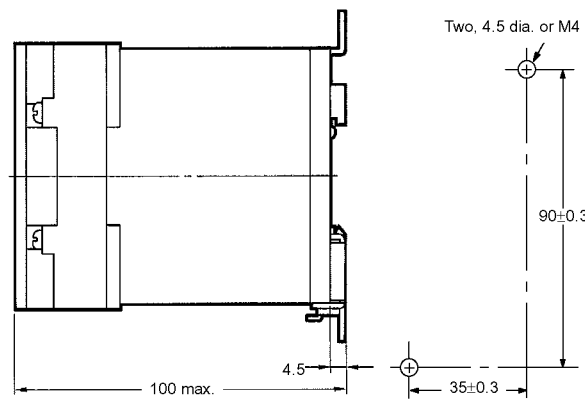
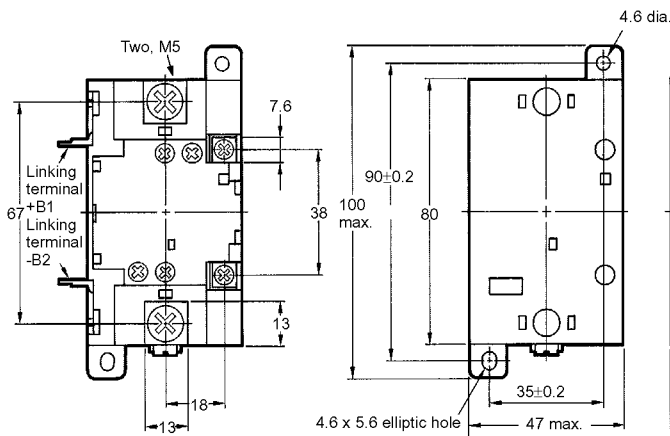

ALL DIMENSIONS SHOWN ARE IN MILLIMETERS.
To convert millimeters into inches, multiply by 0.03937. To convert grams into ounces, multiply by 0.03527.

Cat. No. K094-E1-3A

Solid-state Relay

G3PB

New Single-phase Solid-state Relay with Compact Size and Low Cost

- Lower cost based on new modular construction
- Models for 15 to 45 A are available
- Slim models with a thickness of only 22.5 mm are also available
- Compact design achieved by optimizing radiator shape.
- DIN track mounting possible (when using the Y92B-P50) in addition to screw mounting.
- Meets EN60947-4-3 (IEC947-4-3) UL508, and CSA22.2 No. 14.
- CE marking



Ordering Information

No. of phases	Zero-cross function	Main circuit voltage	Applicable heater capacity (resistive load: Class-1 AC)	Model
Single-phase	Yes	100 to 240 VAC	3.6 kW max. (15 A)	G3PB-215B-VD
			6 kW max. (25 A)	G3PB-225B-VD
			8.4 kW max. (35 A)	G3PB-235B-VD
			10.8 kW max. (45 A)	G3PB-245B-VD

■ Accessories (Order Separately)

Mounting Track	Dimensions	Part Number
	50 cm (1) x 7.3 mm (t)	PFP-50N
	1 m (1) x 7.3 mm (t)	PFP-100N
	1 m (1) x 16 mm (t)	PFP-100N2

Specifications

■ Ratings (at an Ambient Temperature of 25°C)

Operating Circuit (Common)

Item	Common
Rated operating voltage	12 to 24 VDC
Operating voltage range	9.6 to 30 VDC
Rated input current	7 mA max.
Must-operate voltage	9.6 VDC max.
Reset voltage	1 VDC min.
Insulation method	Phototriac
Operation indicator	Yellow LED

Main Circuit of Models with Built-in Heat Sinks

Item	G3PB-215B-VD	G3PB-225B-VD	G3PB-235B-VD	G3PB-245B-VD
Rated voltage	100 to 240 VAC			
Operating voltage range	75 to 264 VAC			
Rated carry current	15 A	25 A	35 A	45 A
Minimum load current	0.1 A			0.5 A
Inrush current resistance (peak value)	150 A (60 Hz, 1 cycle)	220 A (60 Hz, 1 cycle)	440 A (60 Hz, 1 cycle)	
Permissible I ² t (half 60-Hz wave)	121 A ² s	260 A ² s	1,260 A ² s	
Applicable load (with Class-1 AC resistive load)	3 kW max. (at 200 VAC)	5 kW max. (at 200 VAC)	7 kW max. (at 200 VAC)	9 kW max. (at 200 VAC)

■ Characteristics

Item	G3PB-215B-VD	G3PB-225B-VD	G3PB-235B-VD	G3PB-245B-VD
Operate time	1/2 of load power source cycle + 1 ms max. (DC input)			
Release time	1/2 of load power source cycle + 1 ms max. (DC input)			
Output ON voltage drop	1.6 V (RMS) max.			
Leakage current	10 mA max. (at 200 VAC)			
Insulation resistance	100 MΩ min. (at 500 VDC)			
Dielectric strength	2,500 VAC, 50/60 Hz for 1 min			
Vibration resistance	Destruction and malfunction: 10 to 55 Hz, 0.75-mm double amplitude			
Shock resistance	Destruction: 294 m/s ² Malfunction: 294 m/s ² (DIN track mounting)			
Ambient temperature	Operating: -30°C to 80°C (with no icing or condensation) Storage: -30°C to 100°C (with no icing or condensation)			
Ambient humidity	Operating: 45% to 85%			
Approved standards	UL508 File No. E64562 (From April 1999) CSA22.2 No. 14 File No. LR35535 (From April 1999) IEC947-4-3 File No. 6825 UG			
Weight	Approx. 240 g	Approx. 240 g	Approx. 400 g	Approx. 400 g

Compact, Low-cost SSR Contactor of an Innovative Construction is Ideal for Three-phase Heaters

- Slim Unit with three-phase output.
- Optimum heat sinks attach to models without built-in heat sinks.
- Low-cost element module of an innovative construction.
- Compact design achieved by optimizing radiator shape.
- DIN track mounting possible (G3PB-215B-2-VD, G3PB-415B-2-VD) in addition to screw mounting.
- Meets EN60947-4-3 (IEC947-4-3) UL508, and CSA22.2 No. 14.
- CE marking



Ordering Information

■ Models with Built-in Heat Sinks

Number of phases	Number of elements	Zero-cross function	Main circuit voltage	Applicable heater capacity (with Class-1 AC resistive load)	Model
3	3	Yes	100 to 240 VAC	5.1 kW max. (15 A)	G3PB-215B-3-VD
	2			8.6 kW max. (25 A)	G3PB-215B-2-VD
	3				G3PB-225B-3-VD
	2			G3PB-225B-2-VD	
	3			12.1 kW max. (35 A)	G3PB-235B-3-VD
	2			G3PB-235B-2-VD	
	3			15.5 kW max. (45 A)	G3PB-245B-3-VD
	2			G3PB-245B-2-VD	
	3		200 to 400 VAC	10.3 kW max. (15 A)	G3PB-415B-3-VD
	2			G3PB-415B-2-VD	
	3			17.3 kW max. (25 A)	G3PB-425B-3-VD
	2			G3PB-425B-2-VD	
	3			24.2 kW max. (35 A)	G3PB-435B-3-VD
	2			G3PB-435B-2-VD	
	3			31.1 kW max. (45 A)	G3PB-445B-3-VD
	2			G3PB-445B-2-VD	

■ Models without Built-in Heat Sinks

Number of phases	Number of elements	Zero-cross function	Main circuit voltage	Rated carry current	Model
3	3	Yes	100 to 240 VAC	15 A max.	G3PB-215B-3H-VD
	2				G3PB-215B-2H-VD
	3			25 A max.	G3PB-225B-3H-VD
	2				G3PB-225B-2H-VD
	3			35 A max.	G3PB-235B-3H-VD
	2				G3PB-235B-2H-VD
	3			45 A max.	G3PB-245B-3H-VD
	2				G3PB-245B-2H-VD
	3			200 to 400 VAC	15 A max.
	2		G3PB-415B-2H-VD		
	3		25 A max.		G3PB-425B-3H-VD
	2				G3PB-425B-2H-VD
	3		35 A max.		G3PB-435B-3H-VD
	2				G3PB-435B-2H-VD
	3		45 A max.		G3PB-445B-3H-VD
	2				G3PB-445B-2H-VD

Note: The load current vs. ambient temperature characteristics of the Unit vary with the heat radiation of the Unit. Refer to page 110, *Engineering Data* for details.

■ Heat Sinks

Model	Heat resistance (°C/W)
Y92B-P50	1.67
Y92B-P100	1.01
Y92B-P150	0.63
Y92B-P200	0.43
Y92B-P250	0.36

■ Accessories (Order Separately)

Mounting Track	Dimensions	Model
	50 cm (1) x 7.3 mm (t)	PFP-50N
	1 m (1) x 7.3 mm (t)	PFP-100N
	1 m (1) x 16 mm (t)	PFP-100N2

Specifications

■ Ratings (at an Ambient Temperature of 25°C)

Operating Circuit (Common)

Item	Common
Rated operating voltage	12 to 24 VDC
Operating voltage range	9.6 to 30 VDC
Rated input current	10 mA max. (at 24 VDC)
Must-operate voltage	9.6 VDC max.
Reset voltage	1 VDC min.
Insulation method	Phototriac
Operation indicator	Yellow LED

Main Circuit of Models with Built-in Heat Sinks

Item	G3PB-215B-3-VD	G3PB-215B-2-VD	G3PB-225B-3-VD	G3PB-225B-2-VD	G3PB-235B-3-VD	G3PB-235B-2-VD	G3PB-245B-3-VD	G3PB-245B-2-VD
Rated voltage	100 to 240 VAC							
Operating voltage range	75 to 264 VAC							
Rated carry current	15 A		25 A		35 A		45 A	
Minimum load current	0.2 A				0.5 A			
Inrush current resistance (peak value)	150 A (60 Hz, 1 cycle)		220 A (60 Hz, 1 cycle)		440 A (60 Hz, 1 cycle)			
Permissible I ² t (half 60-Hz wave)	121 A ² s		260 A ² s		1,260 A ² s			
Applicable load (with Class-1 AC resistive load)	5.1 kW max.		8.6 kW		12.1 kW max.		15.5 kW max.	

Item	G3PB-415B-3-VD	G3PB-415B-2-VD	G3PB-425B-3-VD	G3PB-425B-2-VD	G3PB-435B-3-VD	G3PB-435B-2-VD	G3PB-445B-3-VD	G3PB-445B-2-VD
Rated voltage	200 to 400 VAC							
Operating voltage range	180 to 440 VAC							
Rated carry current (see note)	15 A		25 A		35 A		45 A	
Minimum load current	0.5 A							
Inrush current resistance (peak value)	220 A (60 Hz, 1 cycle)				440 A (60 Hz, 1 cycle)			
Permissible I ² t (half 60-Hz wave)	260 A ² s				1,260 A ² s			
Applicable load (with Class-1 AC resistive load)	10.3 kW max.		17.3 kW max.		24.2 kW max.		31.1 kW max.	

Note: Rated carry current varies depending on the ambient temperature. For details, refer to *Load Current vs. Ambient Temperature* in *Engineering Data*.

Main Circuit of Models without Built-in Heat Sinks

Item	G3PB-215B-3H-VD	G3PB-215B-2H-VD	G3PB-225B-3H-VD	G3PB-225B-2H-VD	G3PB-235B-3H-VD	G3PB-235B-2H-VD	G3PB-245B-3H-VD	G3PB-245B-2H-VD
Rated voltage	100 to 240 VAC							
Operating voltage range	75 to 264 VAC							
Rated carry current (see note)	15 A		25 A		35 A		45 A	
Minimum load current	0.2 A				0.5 A			
Inrush current resistance (peak value)	150 A (60 Hz, 1 cycle)		220 A (60 Hz, 1 cycle)		440 A (60 Hz, 1 cycle)			
Permissible I ² t (half 60-Hz wave)	121 A ² s		260 A ² s		1,260 A ² s			
Applicable load (with Class-1 AC resistive load)	The applicable load varies with the heat radiation of the Unit. Refer to page 110, <i>Engineering Data</i> for details.							

Item	G3PB-415B-3H-VD	G3PB-415B-2H-VD	G3PB-425B-3H-VD	G3PB-425B-2H-VD	G3PB-435B-3H-VD	G3PB-435B-2H-VD	G3PB-445B-3H-VD	G3PB-445B-2H-VD
Rated voltage	200 to 400 VAC							
Operating voltage range	180 to 440 VAC							
Rated carry current	15 A		25 A		35 A		45 A	
Minimum load current	0.5 A							
Inrush current resistance (peak value)	220 A (60 Hz, 1 cycle)				440 A (60 Hz, 1 cycle)			
Permissible I ² t (half 60-Hz wave)	260 A ² s				1,260 A ² s			
Applicable load (with Class-1 AC resistive load)	Refer to page 110, <i>Engineering Data</i> for details.							

Note: The rated carry current varies depending on the radiation device or radiation plate to be connected and the ambient temperature. For details, refer to *Load Current vs. Ambient Temperature* in *Engineering Data*.

■ Characteristics

Models with Built-in Heat Sinks

Item	G3PB-215B-3-VD	G3PB-215B-2-VD	G3PB-225B-3-VD	G3PB-225B-2-VD	G3PB-235B-3-VD	G3PB-235B-2-VD	G3PB-245B-3-VD	G3PB-245B-2-VD
Operate time	1/2 of load power source cycle + 1 ms max. (DC input)							
Release time	1/2 of load power source cycle + 1 ms max. (DC input)							
Output ON voltage drop	1.6 V (RMS) max.							
Leakage current (see note)	10 mA (at 200 VAC)							
Insulation resistance	100 MΩ min. (at 500 VDC)							
Dielectric strength	2,500 VAC, 50/60 Hz for 1 min							
Vibration resistance	Destruction and malfunction: 10 to 55 Hz, 0.75-mm double amplitude							
Shock resistance	Destruction: 294 m/s ² Malfunction: 147 m/s ²							
Ambient temperature	Operating: -30°C to 80°C (with no icing or condensation) Storage: -30°C to 100°C (with no icing or condensation)							
Ambient humidity	Operating: 45% to 85%							
Weight	Approx. 750 g	Approx. 750 g	Approx. 900 g	Approx. 750 g	Approx. 1,150 g	Approx. 900 g	Approx. 1,500 g	Approx. 1,150 g
Approved standards	UL508, CSA22.2 No. 14, EN60947-4-3 (IEC947-4-3) (From April 1999)							
EMC	Emission	AC mains	EN55011 Group 1 Class B					
	Emission	Electromagnetic	EN55011 Group 1 Class B					
	Immunity	ESD	IEC947-4-3 4 kV contact discharge 8 kV air discharge					
	Immunity	Electromagnetic	IEC947-4-3 10 V/m (80 MHz to 1 GHz)					
	Immunity	EFT	IEC947-4-3 2 kV AC power-signal line					
	Immunity	Surge transient	IEC947-4-3 2 kV					
	Immunity	RF disturbance	IEC947-4-3, EN50082-2 10 V (0.15 to 80 MHz)					

Note: The leakage current of phase S will be approximately $\sqrt{3}$ times larger if the 2-element model is applied.

Item	G3PB-415B-3-VD	G3PB-415B-2-VD	G3PB-425B-3-VD	G3PB-425B-2-VD	G3PB-435B-3-VD	G3PB-435B-2-VD	G3PB-445B-3-VD	G3PB-445B-2-VD
Operate time	1/2 of load power source cycle + 1 ms max. (DC input)							
Release time	1/2 of load power source cycle + 1 ms max. (DC input)							
Output ON voltage drop	1.8 V (RMS) max.							
Leakage current (see note)	20 mA (at 400 VAC)							
Insulation resistance	100 MΩ min. (at 500 VDC)							
Dielectric strength	2,500 VAC, 50/60 Hz for 1 min							
Vibration resistance	Destruction and malfunction: 10 to 55 Hz, 0.75-mm double amplitude							
Shock resistance	Destruction: 294 m/s ² Malfunction: 147 m/s ²							
Ambient temperature	Operating: -30°C to 80°C (with no icing or condensation) Storage: -30°C to 100°C (with no icing or condensation)							
Ambient humidity	Operating: 45% to 85%							
Weight	Approx. 750 g	Approx. 750 g	Approx. 900 g	Approx. 750 g	Approx. 1,150 g	Approx. 900 g	Approx. 1,500 g	Approx. 1,150 g
Approved standards	UL508, CSA22.2 No. 14, EN60947-4-3 (IEC947-4-3) (From April 1999)							
EMC	Emission	AC mains	EN55011 Group 1 Class B					
	Emission	Electromagnetic	EN55011 Group 1 Class B					
	Immunity	ESD	IEC947-4-3					
			4 kV contact discharge					
			8 kV air discharge					
	Immunity	Electromagnetic	IEC947-4-3					
			10 V/m (80 MHz to 1 GHz)					
	Immunity	EFT	IEC947-4-3					
			2 kV AC power-signal line					
	Immunity	Surge transient	IEC947-4-3					
			2 kV					
	Immunity	RF disturbance	IEC947-4-3, EN50082-2					
			10 V (0.15 to 80 MHz)					

Note: The leakage current of phase S will be approximately $\sqrt{3}$ times larger if the 2-element model is applied.

Models without Built-in Heat Sinks

Item	G3PB-215B-3H-VD	G3PB-215B-2H-VD	G3PB-225B-3H-VD	G3PB-225B-2H-VD	G3PB-235B-3H-VD	G3PB-235B-2H-VD	G3PB-245B-3H-VD	G3PB-245B-2H-VD
Operate time	1/2 of load power source cycle + 1 ms max. (DC input)							
Release time	1/2 of load power source cycle + 1 ms max. (DC input)							
Output ON voltage drop	1.6 V (RMS) max.							
Leakage current (see note)	10 mA (at 200 VAC)							
Insulation resistance	100 MΩ min. (at 500 VDC)							
Dielectric strength	2,500 VAC, 50/60 Hz for 1 min							
Vibration resistance	Destruction and malfunction: 10 to 55 Hz, 0.75-mm single amplitude							
Shock resistance	Destruction: 294 m/s ² Malfunction: 147 m/s ²							
Ambient temperature	Operating: -30°C to 80°C (with no icing or condensation) Storage: -30°C to 100°C (with no icing or condensation)							
Ambient humidity	Operating: 45% to 85%							
Approved standards	UL508, CSA22.2 No. 14, EN60947-4-3 (IEC947-4-3) (From April 1999)							
Weight (Max.)	300 g max.							
EMC	Emission	AC mains	EN55011 Group 1 Class B					
	Emission	Electromagnetic	EN55011 Group 1 Class B					
	Immunity	ESD	IEC947-4-3 4 kV contact discharge 8 kV air discharge					
	Immunity	Electromagnetic	IEC947-4-3 10 V/m (80 MHz to 1 GHz)					
	Immunity	EFT	IEC947-4-3 2 kV AC power-signal line					
	Immunity	Surge transient	IEC947-4-3 2 kV					
	Immunity	RF disturbance	IEC947-4-3, EN50082-2 10 V (0.15 to 80 MHz)					

Note: The leakage current of phase S will be approximately $\sqrt{3}$ times larger if the 2-element model is applied.

Item	G3PB-415B-3H-VD	G3PB-415B-2H-VD	G3PB-425B-3H-VD	G3PB-425B-2H-VD	G3PB-435B-3H-VD	G3PB-435B-2H-VD	G3PB-445B-3H-VD	G3PB-445B-2H-VD
Operate time	1/2 of load power source cycle + 1 ms max. (DC input)							
Release time	1/2 of load power source cycle + 1 ms max. (DC input)							
Output ON voltage drop	1.8 V (RMS) max.							
Leakage current (see note)	20 mA (at 400 VAC)							
Insulation resistance	100 MΩ min. (at 500 VDC)							
Dielectric strength	2,500 VAC, 50/60 Hz for 1 min							
Vibration resistance	Destruction and malfunction: 10 to 55 Hz, 0.75-mm single amplitude							
Shock resistance	Destruction: 294 m/s ² Malfunction: 147 m/s ²							
Ambient temperature	Operating: -30°C to 80°C (with no icing or condensation) Storage: -30°C to 100°C (with no icing or condensation)							
Ambient humidity	Operating: 45% to 85%							
Approved standards	UL508, CSA22.2 No. 14, EN60947-4-3 (IEC947-4-3) (From April 1999)							
Weight	Approx. 300 g							
EMC	Emission	AC mains	EN55011 Group 1 Class B					
	Emission	Electromagnetic	EN55011 Group 1 Class B					
	Immunity	ESD	IEC947-4-3 4 kV contact discharge 8 kV air discharge					
	Immunity	Electromagnetic	IEC947-4-3 10 V/m (80 MHz to 1 GHz)					
	Immunity	EFT	IEC947-4-3 2 kV AC power-signal line					
	Immunity	Surge transient	IEC947-4-3 2 kV					
	Immunity	RF disturbance	IEC947-4-3, EN50082-2 10 V (0.15 to 80 MHz)					

Note: The leakage current of phase S will be approximately $\sqrt{3}$ times larger if the 2-element model is applied.

Heat Sinks

Model	Weight
Y92B-P50	Approx. 450 g
Y92B-P100	Approx. 450 g
Y92B-P150	Approx. 600 g
Y92B-P200	Approx. 850 g
Y92B-P250	Approx. 1,200 g

Engineering Data

■ Load Current vs. Ambient Temperature (Continuous Input)

Models with Built-in Heat Sinks

Three-phase Models

- | | | | |
|----------------|----------------|----------------|----------------|
| G3PB-215B-3-VD | G3PB-225B-3-VD | G3PB-235B-3-VD | G3PB-245B-3-VD |
| G3PB-215B-2-VD | G3PB-225B-2-VD | G3PB-235B-2-VD | G3PB-245B-2-VD |
| G3PB-415B-3-VD | G3PB-425B-3-VD | G3PB-435B-3-VD | G3PB-445B-3-VD |
| G3PB-415B-2-VD | G3PB-425B-2-VD | G3PB-435B-2-VD | G3PB-445B-2-VD |

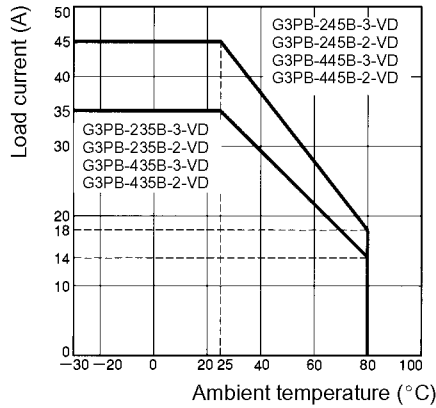
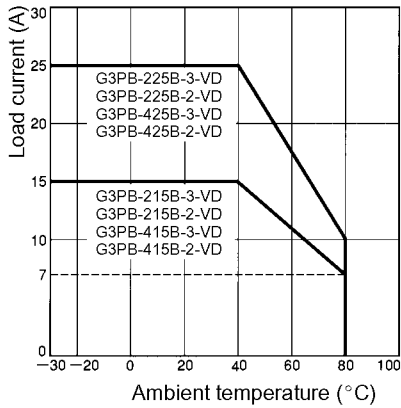

Single-phase Models

- | | |
|--------------|--------------|
| G3PB-215B-VD | G3PB-235B-VD |
| G3PB-225B-VD | G3PB-245B-VD |

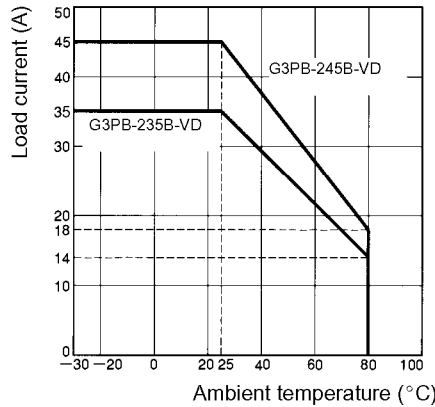
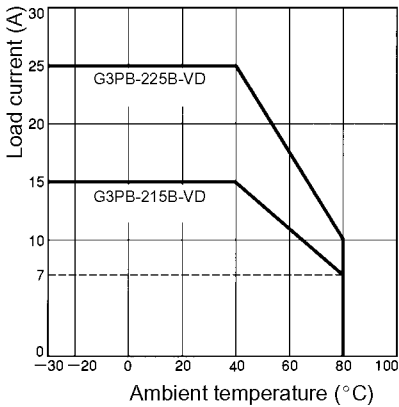

Models without Built-in Heat Sinks

- | | |
|-----------------------|-----------------------|
| G3PB-215B-3H (-2H)-VD | G3PB-235B-3H (-2H)-VD |
| G3PB-225B-3H (-2H)-VD | G3PB-245B-3H (-2H)-VD |
| G3PB-415B-3H (-2H)-VD | G3PB-435B-3H (-2H)-VD |
| G3PB-425B-3H (-2H)-VD | G3PB-445B-3H (-2H)-VD |

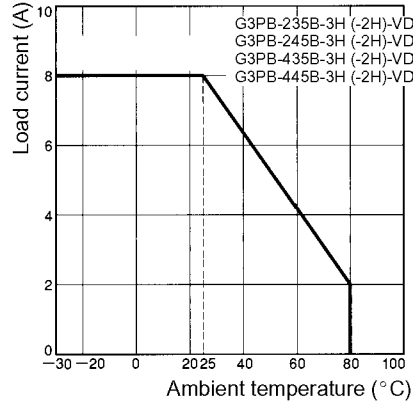
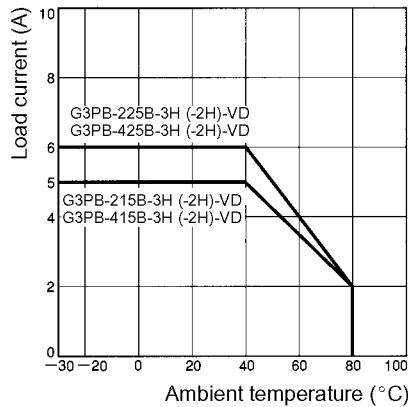

■ Inrush Current Resistivity: Non-repetitive (Less than Half for Repetitive)

Three-phase Models

G3PB-215B-3 (H)-VD
G3PB-215B-2 (H)-VD

G3PB-225B-3 (H)-VD G3PB-425B-3 (H)-VD
G3PB-225B-2 (H)-VD
G3PB-415B-3 (H)-VD G3PB-425B-2 (H)-VD
G3PB-415B-2 (H)-VD

G3PB-235B-3 (H)-VD G3PB-435B-3 (H)-VD
G3PB-235B-2 (H)-VD G3PB-435B-2 (H)-VD
G3PB-245B-3 (H)-VD G3PB-445B-3 (H)-VD
G3PB-245B-2 (H)-VD G3PB-445B-2 (H)-VD

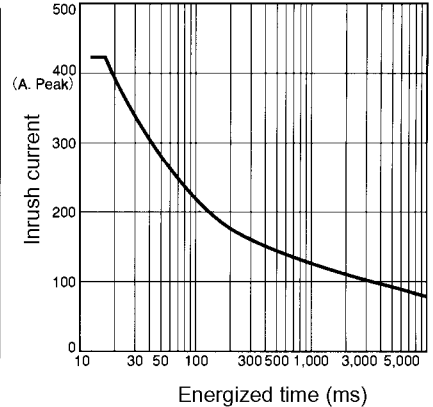
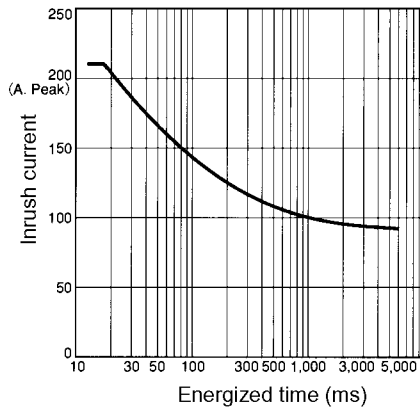
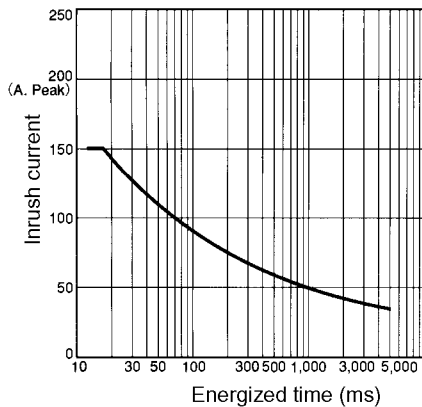

Single-phase Models

G3PB-215B-VD

G3PB-225B-VD

G3PB-235B-VD
G3PB-245B-VD

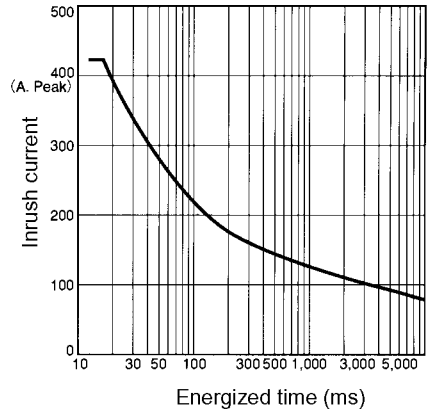
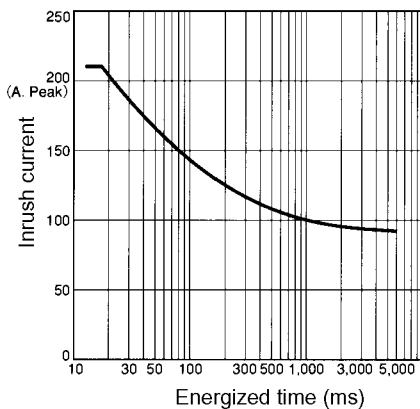
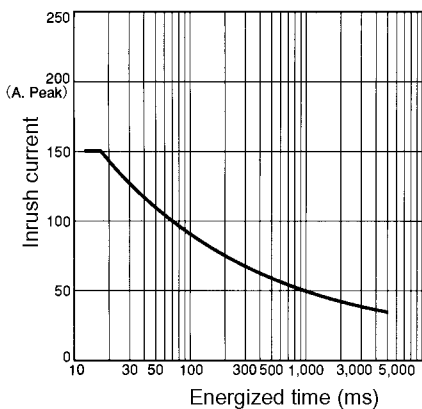

■ Heat Sink Size vs. Load Current

Three-phase Models

G3PB-225B-3H-VD

G3PB-425B-3H-VD

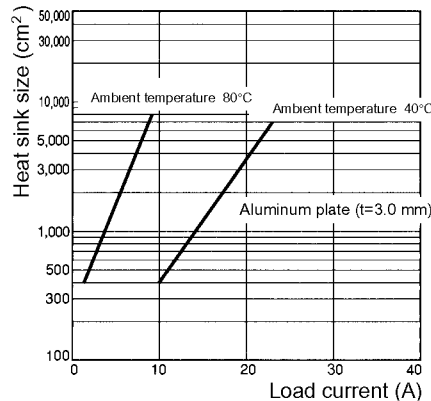
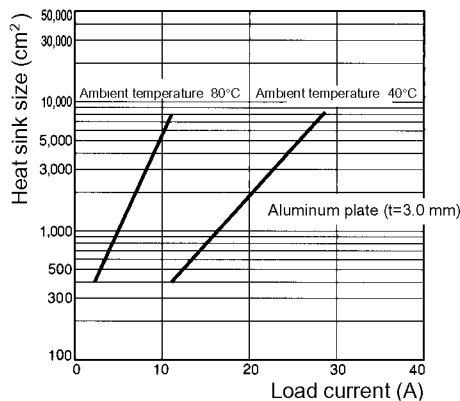

Note: The heat sink size refers to the combined area of the sides of the heat sink that radiate heat. In the case of G3PB-425B-3H-VD, when a current of 18 A is allowed to flow through the SSR at 40°C, the graph shows that the heat sink size is about 2,500 cm². Therefore, if the heat sink is square, one side of the heat sink must be 36 cm (36² × 2 = 2,592) or longer.

■ Input Voltage vs. Input Current and Input Voltage vs. Input Impedance Three-phase Models

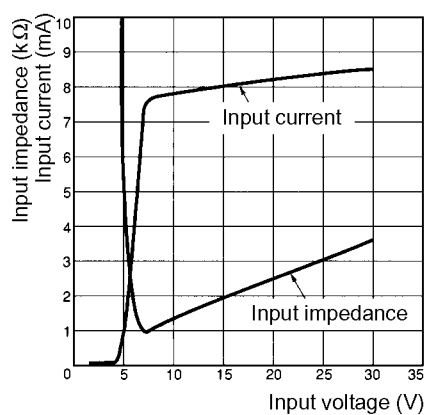

Single-phase Models

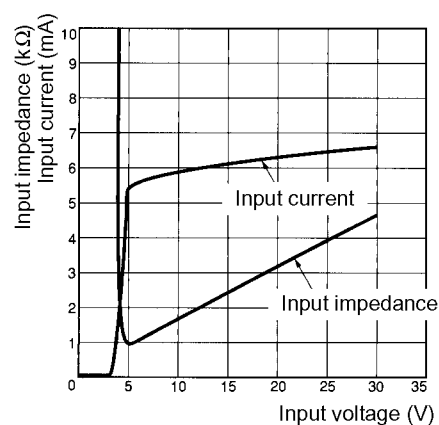

■ Thermal Resistance Rth (Junction/SSR Back Surface) Three-phase Models without Heat Sink

Model	Rth (°C/W)
G3PB-215B-3H-VD	1.05
G3PB-225B-3H-VD	0.57
G3PB-235B-3H-VD	0.57
G3PB-245B-3H-VD	0.57

Dense Mounting (3 Relays, 8 Relays)

G3PB-215B-VD

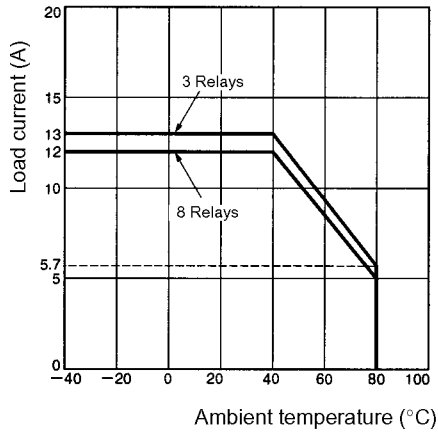

G3PB-225B-VD

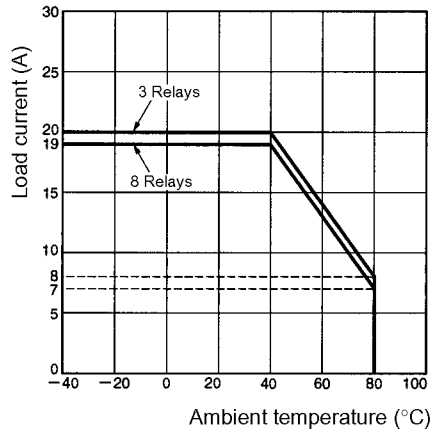

G3PB-235B-VD

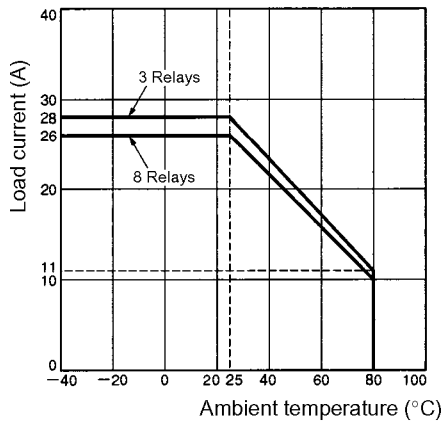

G3PB-245B-VD

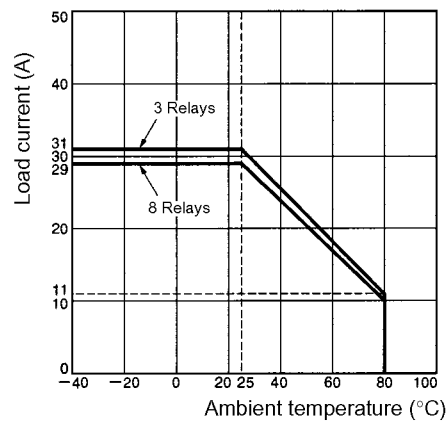

Dense Mounting Example

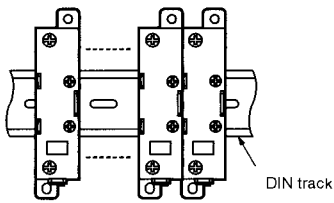

Dimensions

Note: All units are in millimeters unless otherwise indicated.

Models with Built-in Heat Sinks

Three-phase Models

G3PB-215B-2-VD
G3PB-415B-2-VD

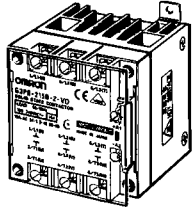

Without Terminal Cover

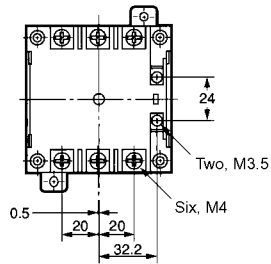

With Terminal Cover

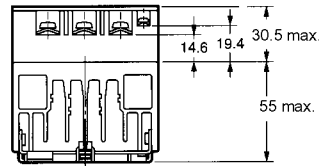
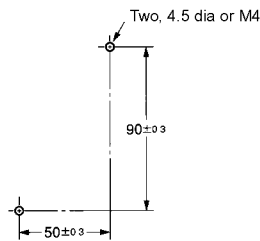
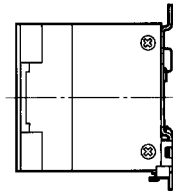
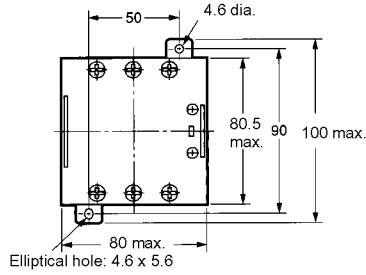

Terminal Arrangement/
Internal Circuit Diagram

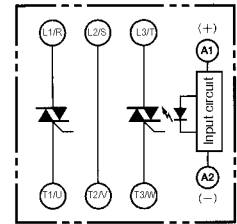

G3PB-215B-3-VD
G3PB-225B-2-VD
G3PB-415B-3-VD
G3PB-425B-2-VD

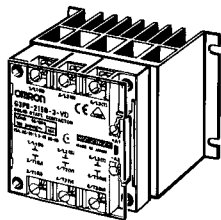

Without Terminal Cover

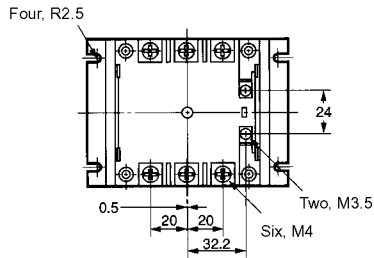

With Terminal Cover

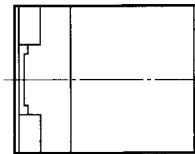
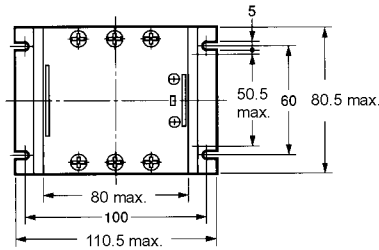

Mounting Holes

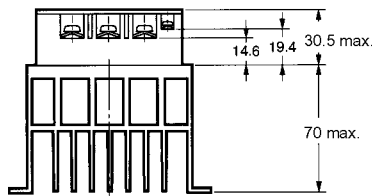
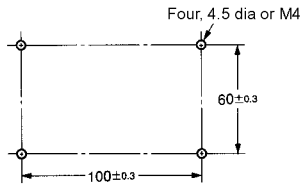

Terminal Arrangement/
Internal Circuit Diagram

G3PB-□□□B-3-VD

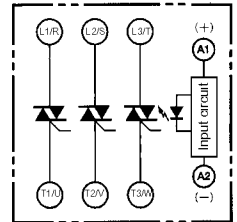

G3PB-□□□B-2-VD

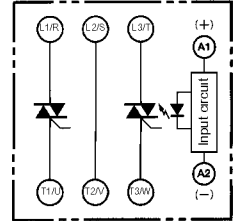

G3PB-225B-3-VD
 G3PB-235B-2-VD
 G3PB-425B-3-VD
 G3PB-435B-2-VD

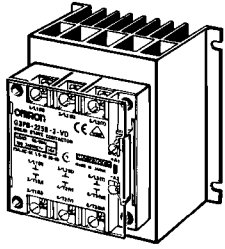

Without Terminal Cover

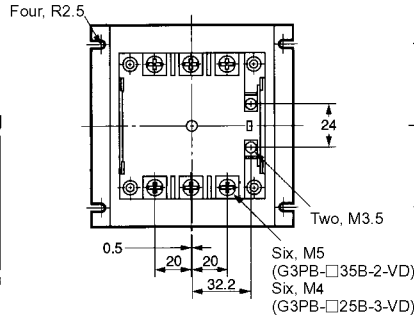

With Terminal Cover

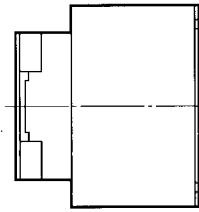
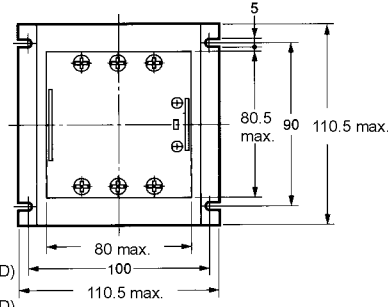

Terminal Arrangement/
Internal Circuit Diagram

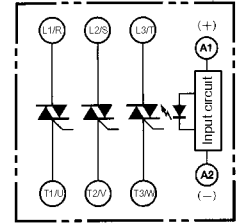

Mounting Holes

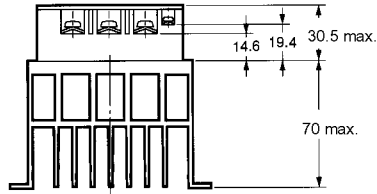
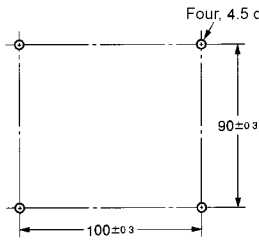

G3PB-235B-3-VD
 G3PB-245B-2-VD
 G3PB-435B-3-VD
 G3PB-445B-2-VD

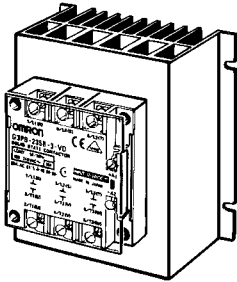

Without Terminal Cover

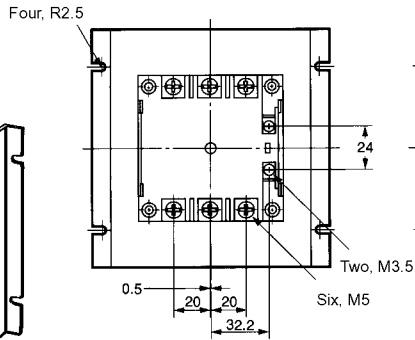

With Terminal Cover

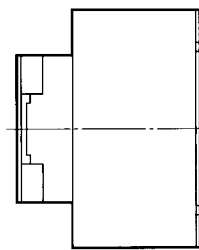
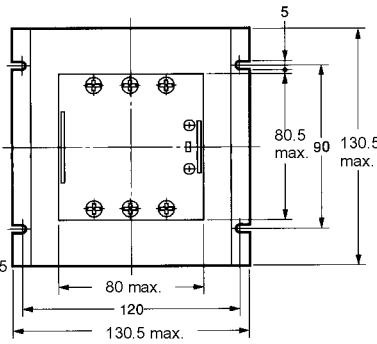

Terminal Arrangement/
Internal Circuit Diagram

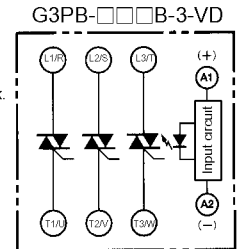

Mounting Holes

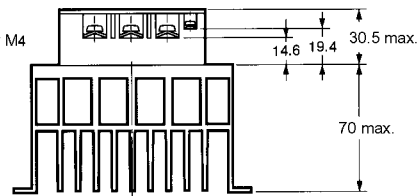
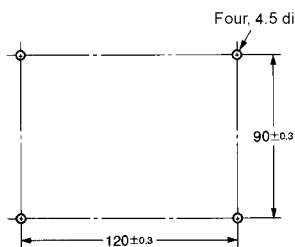

G3PB-□□□B-2-VD

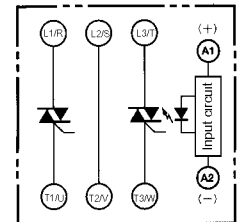

G3PB-245B-3-VD
G3PB-445B-3-VD

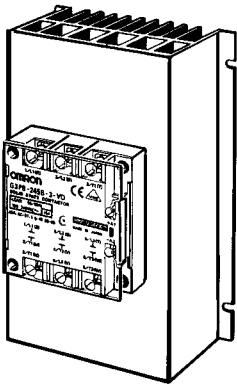

Without Terminal Cover

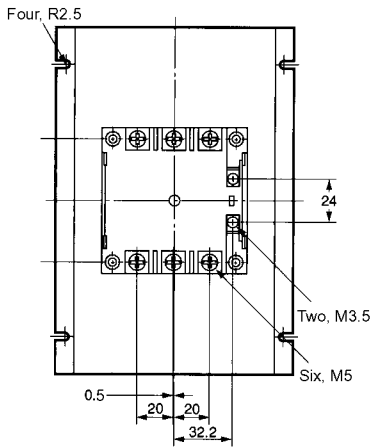

With Terminal Cover

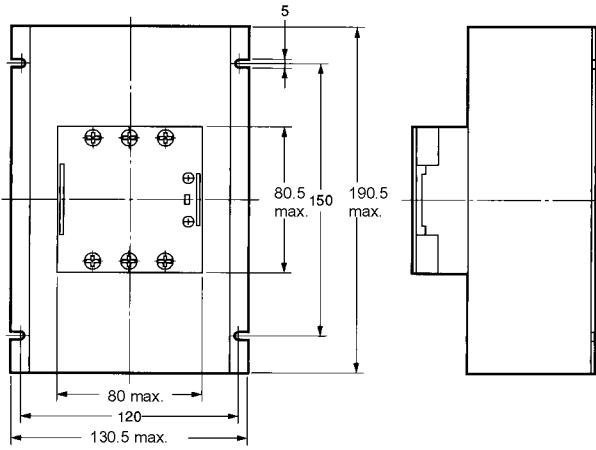

Mounting Holes

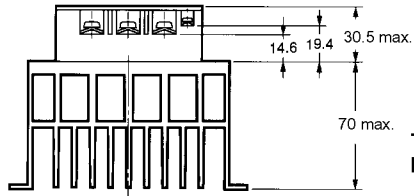
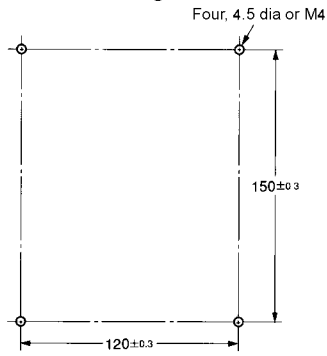

Terminal Arrangement/
Internal Circuit Diagram

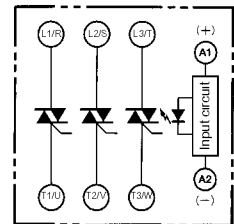

Single-phase Models

G3PB-215B-VD
G3PB-225B-VD

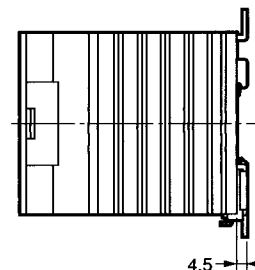
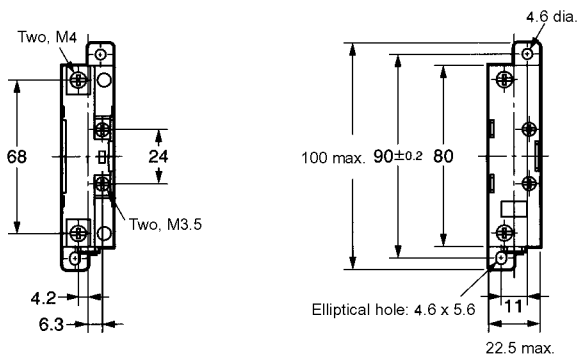
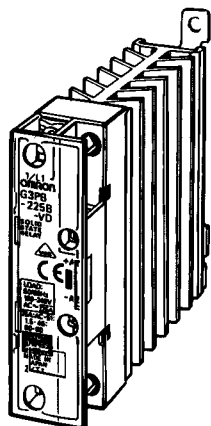

Mounting Holes

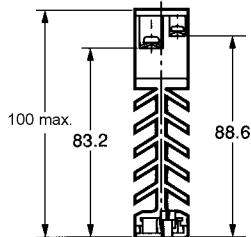
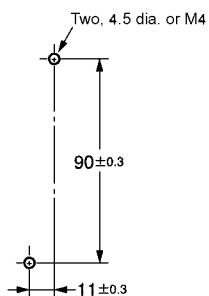

Terminal Arrangement/
Internal Circuit Diagram

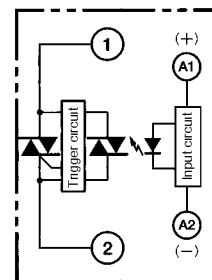

G3PB-235B-VD
G3PB-245B-VD

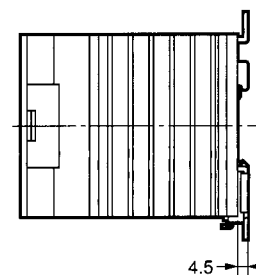
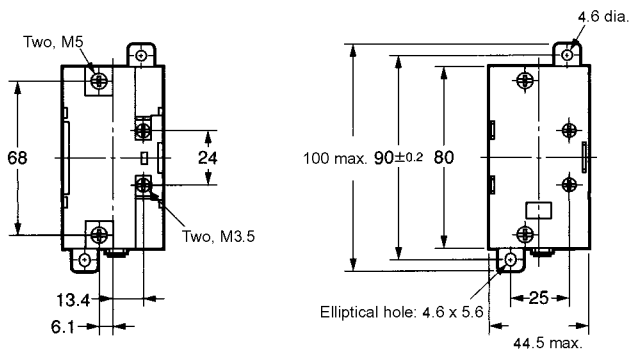
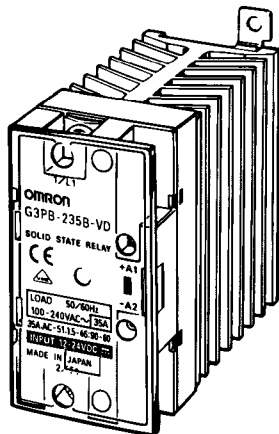

Mounting Holes

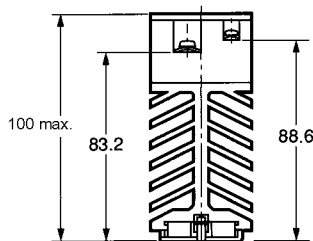
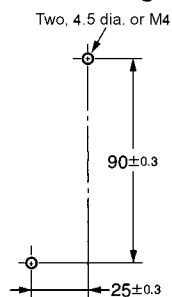

Terminal Arrangement/
Internal Circuit Diagram

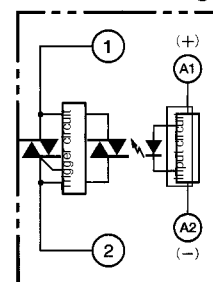

Models without Built-in Heat Sinks

- G3PB-215B-3H-VD G3PB-235B-3H-VD G3PB-415B-3H-VD G3PB-435B-3H-VD
- G3PB-215B-2H-VD G3PB-235B-2H-VD G3PB-415B-2H-VD G3PB-435B-2H-VD
- G3PB-225B-3H-VD G3PB-245B-3H-VD G3PB-425B-3H-VD G3PB-445B-3H-VD
- G3PB-225B-2H-VD G3PB-245B-2H-VD G3PB-425B-2H-VD G3PB-445B-2H-VD

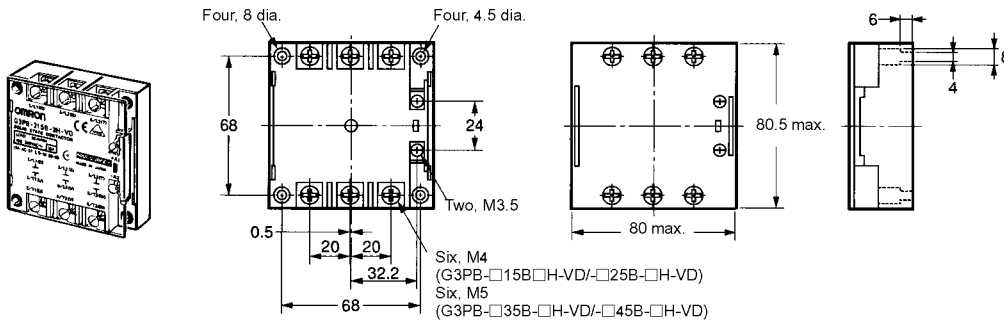

**Terminal Arrangement/
Internal Circuit Diagram**

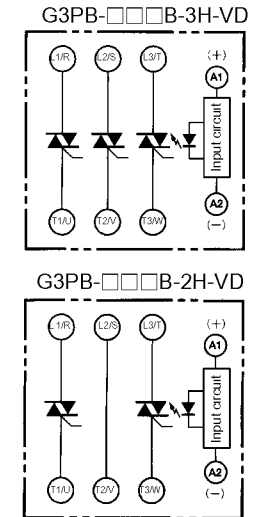

Mounting Holes

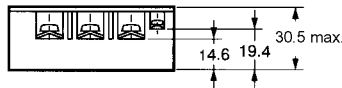
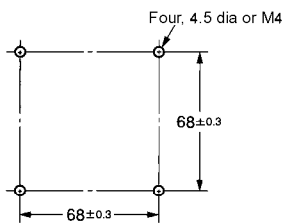

Heat Sinks

Y92B-P50

For model G3PB-215B-2H-VD
G3PB-415B-2H-VD

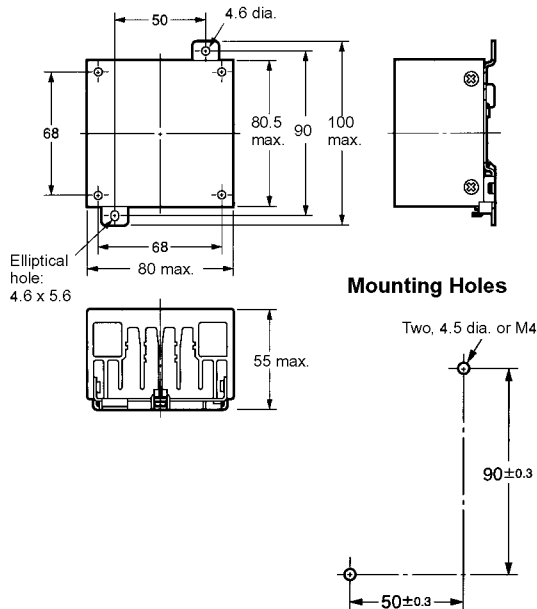

Mounting Holes

Y92B-P100

For G3PB-215B-3H-VD
G3PB-225B-2H-VD
G3PB-415B-3H-VD
G3PB-425B-2H-VD

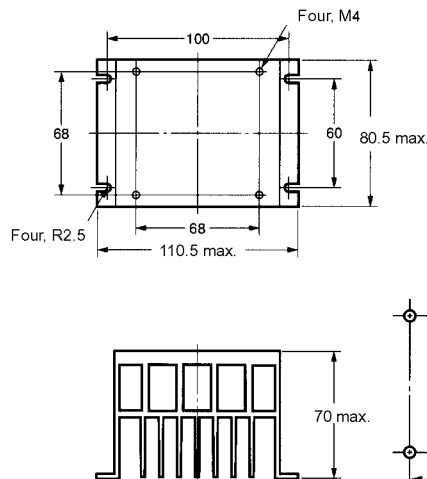

Mounting Holes

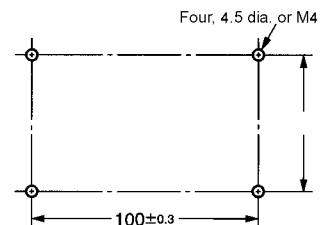

Y92B-P150

For model G3PB-225B-3H-VD
G3PB-235B-2H-VD
G3PB-425B-3H-VD
G3PB-435B-2H-VD

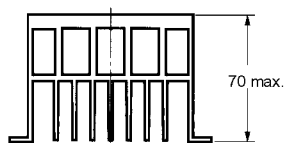
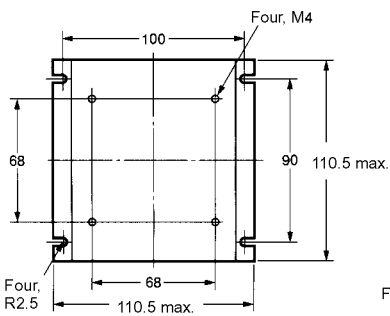

Mounting Holes

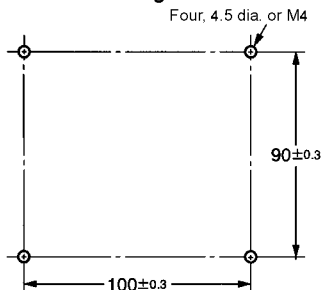

Y92B-P200

For model G3PB-235B-3H-VD
G3PB-245B-2H-VD
G3PB-435B-3H-VD
G3PB-445B-2H-VD

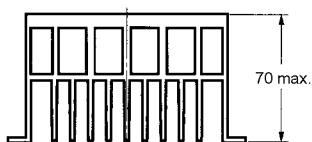
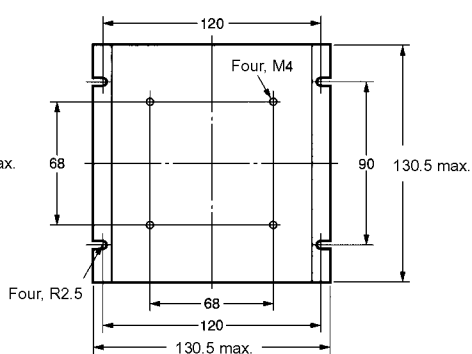

Mounting Holes

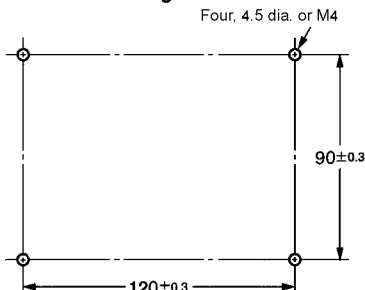

Y92B-P250

For model G3PB-245B-3-VD
G3PB-445B-3-VD

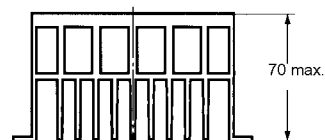
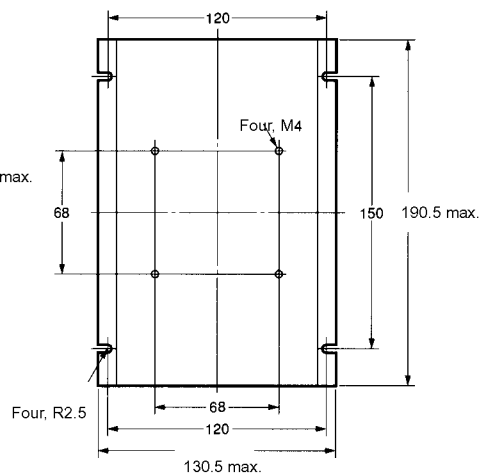

Mounting Holes

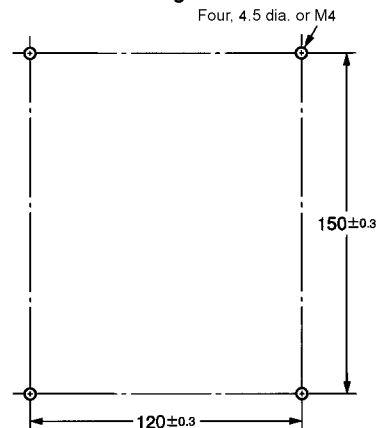

Accessories (Order Separately)

Mounting Tracks

PFP-100N, PFP-50N

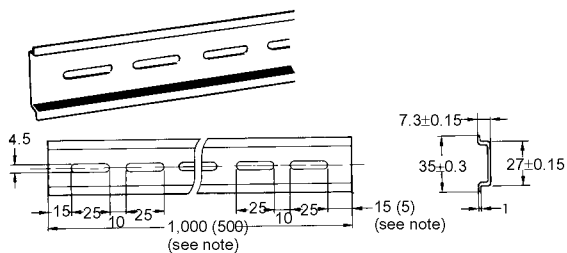

PFP-100N2

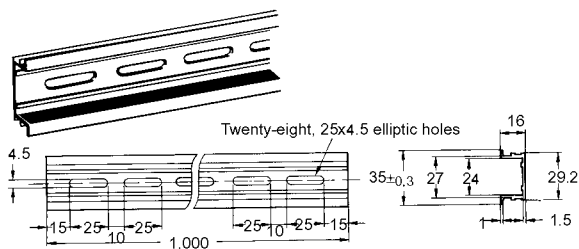

Note: Values in parentheses indicate dimensions for the PFP-50N.

Precautions

⚠ WARNING

Do not touch the terminals (i.e., charged parts) of the G3PB while power is supplied, otherwise an electric shock may be received.

If the G3PB is provided with a terminal cover, be sure to attach the terminal cover to the G3PB before operating the G3PB.

The G3PB and radiator are very hot while power is supplied to the G3PB.

Do not touch the G3PB or the radiator while power is supplied to the G3PB or immediately after the G3PB is turned OFF, otherwise a burn may result.

Do not touch the load terminal of the G3PB immediately after the G3PB is turned OFF, otherwise an electric shock may be received due to the residual charge of the built-in snubber circuit.

Be sure to turn OFF the power supply to the G3PB before wiring, otherwise an electric shock may be received.

Mount the terminal cover to the G3PB after wiring.

Do not touch the terminals of the G3PB while power is supplied, otherwise an electric shock may be received.

The built-in capacitor will be charged as long as power is supplied. Do not touch the terminals of the G3PB unless the G3PB is turned OFF and the built-in capacitor discharges all of its residual voltage, otherwise an electric shock may result.

⚠ Caution

Do not apply excessive voltage or current to the input or output circuit of the G3PB, otherwise the G3PB may malfunction or burn.

Do not use the G3PB unless all the output terminal screws are tightened securely, otherwise the terminals may generate excessive heat and the G3PB may burn.

Be sure to provide enough ventilation to the G3PB and the radiator, otherwise the G3PB may generate excessive heat and the G3PB may burn or the output element may short-circuit.

Be sure to turn OFF the power supply to the G3PB before wiring, otherwise an electric shock may be received.

Be sure to wire or solder the terminals of the G3PB properly, otherwise the G3PB may generate excessive heat and burn.

If the G3PB is mounted directly to a control panel that is used as a radiator as well, the control panel must be made of aluminum or a steel plate with low thermal resistance.

Do not use any material with high thermal resistance, such as a wooden plate, otherwise the G3PB may catch on fire or burn.

■ Correct Use

Before Actual Operation

- The G3PB in operation may cause an unexpected accident. Therefore it is necessary to test the G3PB under a variety of conditions that are possible. As for the characteristics of the G3PB, it is necessary to take into consideration the dispersion of the characteristics between G3PB Units.
- The ratings in this datasheet are tested values in a temperature range between 15°C and 30°C, a relative humidity range between 25% and 85%, and an atmospheric pressure range between 88 and 106 kPa. It will be necessary to provide the above conditions as well as the load conditions if the user wants to confirm the ratings of actual G3PB Units.

Mounting Method

Since the Relay is heavy, firmly mount the DIN track and fix both ends with End Plates for DIN-track-mounting models.

For direct mounting, firmly mount the Relay on the panel.

Vertical Mounting

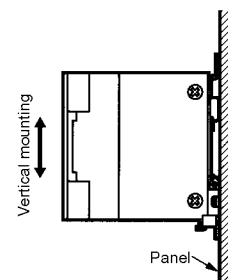

Horizontal Mounting

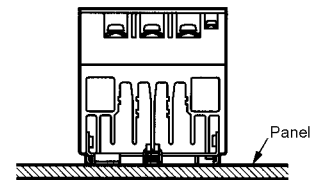

Note: Make sure that the load current is 50% of the rated load current when the G3PB is mounted horizontally.

Close Mounting

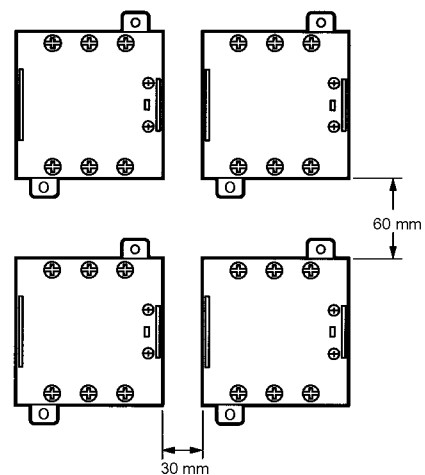

Note: Be sure to provide a minimum space of 30 mm horizontally and 60 mm vertically between adjacent Units.

Wiring

When using crimp terminals, refer to the terminal clearances shown below.

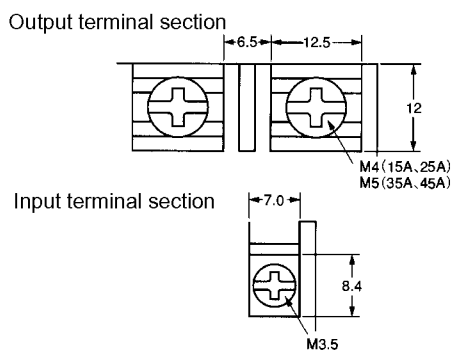

Be sure that all lead wires are thick enough according to the current.

Output terminals T1, T2, and T3 are charged regardless of whether the Unit is a 2- or 3-element model that is turned on or off. Do not touch these terminals, otherwise an electric shock may be received.

To isolate the Unit from the power supply, install an appropriate circuit breaker between the power supply and Unit.

Be sure to turn off the power supply before wiring the Unit.

Terminal L2 and terminal T2 of the 2-element model are internally short-circuited to each other. Therefore, connect terminal L2 to the ground terminal of the power supply. If terminal L2 is connected to a terminal other than the ground terminal, cover all the charged terminals, such as heater terminals, for the prevention of electric shock accidents and ground faults.

Tightening Torque

Refer to the following and be sure to tighten each screw of the Unit to the specified torque in order to prevent the Unit from malfunctioning.

Item	Screw terminal diameter	Tightening torque
Input terminal	M3.5	0.8 N • m
Output terminal	M4	1.2 N • m
	M5	2.0 N • m

Mounting Models without Built-in Heat Sink

Before attaching an external radiator or Heat Sink to the Unit, be sure to apply silicone grease for heat radiation, such as Toshiba's YG6260 or Sinetsu Silicone's G746, to the surface where the radiator or Heat Sink is attached.

Be sure to apply the following torque to secure the Unit and external radiator or Heat Sink for proper heat radiation.

Tightening torque: 2.0 N • m

Operating Conditions

Do not apply current exceeding the rated current. Otherwise the temperature of the Unit may rise excessively.

Be sure to prevent ambient temperature rising due to the heat radiation of the Unit. In the case of enclosed mounting, install a fan so that the interior of the panel can be fully ventilated.

Operating and Storage Environments

Do not use or store the Unit in the following places, otherwise the Unit may malfunction or the characteristics of the Unit may deteriorate.

- Locations subject to direct sunlight.
- Locations subject to ambient operating temperatures outside the range of -30°C to 80°C .
- Locations subject to ambient operating humidity outside the range of 45% to 85%.
- Locations subject to condensation as the result of severe changes in temperature.
- Locations subject to ambient storage temperatures outside the range of -30°C to 100°C .
- Locations subject to corrosive or flammable gases.
- Locations subject to dust (especially iron dust) or salts.
- Locations subject to shock or vibration.
- Locations subject to exposure to water, oil, or chemicals.

ALL DIMENSIONS SHOWN ARE IN MILLIMETERS.

To convert millimeters into inches, multiply by 0.03937. To convert grams into ounces, multiply by 0.03527.

Multifunkční analogové časové relé o velikosti DIN 48 x 48 s krytím IP 40 pro všeobecné použití

- Universální napájecí napětí 100 až 120 VDC/100 až 240 VAC nebo 24 až 48 VAC (50/60 Hz)/ 12 až 48 VDC
- 8-mi nebo 11-ti kolíkové modely se 4-mi nebo 6-ti funkcemi
- Nízká spotřeba
- Hloubka relé i s patičkou pro montáž na DIN lištu pouze 80mm
- Všechny funkce, rozsahy a jednotky nastavitelné z čelního panelu
- Splňuje normy IEC a schválení UL a CSA.
- Standard EMC (EN50081-2 a EN50082-2)



Informace pro objednání

11-kolíkové modely

Výstupy	Napájení	Vstup	Časový rozsah	Pracovní módy	Model	
Kontaktní výstup	100 až 240 VAC (50-60 Hz)/ 100 až 125VDC	Beznapěťový	0.05 s až 300 hod	6 módů: A, B, B2, C, D, E	H3CR-A	
	24 až 48 VAC (50/60 Hz)/ 12 až 48 VDC					
	100 až 240 VAC (50-60 Hz)/ 100 až 125VDC			Napěťový	6 módů: A, B, B2, C, D, E	H3CR-AP
	24 až 48 VAC (50/60 Hz)/ 12 až 48 VDC					
	100 až 240 VAC (50-60 Hz)/ 100 až 125VDC	Beznapěťový	0.1 s až 600 hod	6 módů: A, B, B2, C, D, E	H3CR-A-301	
	24 až 48 VAC (50/60 Hz)/ 12 až 48 VDC					
	Tranzistorový výstup (Optočlen)	24 až 48 VAC (50/60 Hz)/ 12 až 48 VDC		0.05 s až 300 hod		H3CR-AS

8-kolíkové modely

Výstupy	Napájení	Vstup	Časový rozsah	Pracovní módy	Model
Kontaktní výstup	100 až 240 VAC (50-60 Hz)/ 100 až 125VDC	Beznapěťový	0.05 s až 300 hod	4 módy: A, B2, E, J	H3CR-A8
	24 až 48 VAC (50/60 Hz)/ 12 až 48 VDC				
	100 až 240 VAC (50-60 Hz)/ 100 až 125VDC		0.1 s až 600 hod	4 módy: A, B2, E, J	H3CR-A8-301
	24 až 48 VAC (50/60 Hz)/ 12 až 48 VDC				
Tranzistorový výstup (Optočlen)	24 až 48 VAC (50/60 Hz)/ 12 až 48 VDC		0.05 s až 300 hod		H3CR-A8S
Časový a mžikový kontaktní výstup	100 až 240 VAC (50-60 Hz)/ 100 až 125VDC				H3CR-A8E
	24 až 48 VDC/VAC				

Poznámka: 1. Při objednávání uvádět napájecí napětí za specifikací typu časového relé
H3CR-A 100 až 240 VAC (50/60 Hz) / 100 až 125 VDC

napájecí napětí

2. Pracovní módy:

A: Zpožděné sepnutí (ON-delay)
B: Periodické spínání (Flicker OFF start)
B2: Periodické spínání (Flicker ON start)
C: Impuls ON/OFF (Signal ON/OFF-delay)

D: Zpožděné rozepnutí (Signal OFF-delay)
E: Interval
G: Zpoždění ON/OFF (Signal ON/OFF-delay)
J: Zpožděný impuls (One-shot)

■ Příslušenství (objednat odděleně)

Montážní rámeček	Y92F-30
	Y92F-73
	Y92F-74

Aretační kroužky	
Aretační kroužek nastavení času	Y92S-27
Aretační kroužek limitní	Y92S-28

Patice	8-mi kolíková	11-ti kolíková
Pro montáž na DIN lištu	P2CF-08	P2CF-11/-11-E
Pro montáž do panelu	P3G-08	P3GA-11/-11-E

Kryt čelního panelu	
Tmavě šedý (5Y7/1)	Y92P-48GL
Černý (N1.5)	Y92P-48GB
Světle šedý (5Y5/1)	Y92P-48GM

DIN lišta	50 cm (d) x 7.3 mm (h)	PFP-50N
	1 m (d) x 7.3 mm (h)	PFP-100N
	1 m (d) x 16 mm (h)	PFP-100N2
Ukončovací člen	PFP-M	
Mezerník	PFP-S	

Ochranné kryty	
Ochranný kryt panelu	Y92A-48B
Ochranný kyt svorek	Y92A-48G

■ Legenda čísla modelu

H3CR-A

1 2 3 4

1. Počet kolíků

- : 11-ti kolíkové modely
8 : 8-mi kolíkové modely

2. Typ vstupu pro 11-ti-kolíkové modely

- : Beznapěťový vstup (NPN)
P : Napěťový vstup (PNP)

3. Výstup

- : Kontaktní výstup (DPDT)
S : Tranzistorový výstup (NPN/PNP)
E : Kontaktní výstup (SPDT) s mžikovým kontaktem (SPDT)

4. Suffix

300: Model s 2 módy
301 : Model s dvojnásobným časovým rozsahem (0.1 s až 600h)

Specifikace

■ Všeobecné

Položka	H3CR-A/-AS	H3CR-AP	H3CR-A8/-A8S	H3CR-A8E
Pracovní módy	A: Zpožděné sepnutí (ON-delay) B: Periodické spínání (Flicker OFF start) B2: Periodické spínání (Flicker ON start) C: Impuls ON/OFF (Signal ON/OFF-delay) D: Zpožděné rozepnutí (Signal OFF-delay) E: Interval G: Zpoždění ON/OFF (Signal ON/OFF-delay) J: Zpožděný impuls (One-shot)		A: Zpožděné sepnutí (ON-delay) B2: Periodické spínání (Flicker ON start) E: Interval J: Zpožděný impuls (One-shot)	
Kontakty	11 kontaktů		8 kontaktů	
Vstup	Beznapěťový	Napěťový	---	
Časový výstup	H3CR-A/-A8/-AP: Reléový výstup (DPDT) H3CR-AS/-A8S : Tranzistorový výstup (NPN/PNP)		Reléový Výstup (SPDT)	
Mžikový kontakt	---		Reléový Výstup (SPDT)	
Montáž	Na DIN lištu, do panelu, na stěnu rozvaděče (pomocí šroubů)			
Certifikace	UL508, CSA C22.2 No.14, NK, Lloyds V souladu s EN61812-1 (VDE0435/P2021), IEC60664-1 (VDE0110) 4kV/2, EN60947-5-1 (kontaktní výstup), a EN60947-5-2 (bezkontaktní výstup)			

■ Časové rozsahy

Standardní (0.05 s až 300 hod) model

Časová jednotka	s (sec)	min	h (hod)	x 10 h (10 hod)
Plný rozsah	1.2	0.05 až 1.2	0.12 až 1.2	1.2 až 12
	3	0.3 až 3		3 až 30
	12	1.2 až 12		12 až 120
	30	3 až 30		30 až 300

Model s dvojnásobným časovým rozsahem (0.1 s až 600 hod)

Časová jednotka	s (sec)	min	h (hod)	x 10 h (10 hod)
Plný rozsah	2.4	0.1 až 2.4	0.24 až 2.4	2.4 až 24
	6	0.6 až 6		6 až 60
	24	2.4 až 24		24 až 240
	60	6 až 60		60 až 600

■ Charakteristiky

Přesnost	±0.2% FS max (+0.2%±10 ms max v rozshu 1.2 s)		
Chyba nastavení	±5%FS ±50ms		
Resetovací čas	Výpadek napájení: 0.1 s max. Min. délka resetovacího impulsu : 0.05 s (H3CR-A/-AS)		
Resetovací napětí	10% max. jmenovitého napětí		
Vliv kolísání napětí	±0.2% FS max max. (+0.2 %±10 ms max v rozsahu 1.2 s)		
Vliv kolísání teploty	±1%FS max (±1%±10 ms max v rozsahu 1.2 s)		
Izolační odpor	min. 100 MΩ (při 500VDC) mezi svorkami, které vedou proud a vystavenými kovovými částmi, kterými proud neprotéká a mezi nespojitými kontakty		
Dielektrická pevnost	2 000 VAC (1 000 VAC pro H3CR-A, S), 50/60 Hz po dobu 1 min (mezi proud vedoucími svorkami a vystavenými kovovými částmi nevedoucími proud) 2 000 VAC (1 000 VAC pro H3CR-A, S), 50/60 Hz po dobu 1 min (mezi nespojitými kontakty) 2 000 VAC, 50/60 Hz po dobu 1 min (mezi svorkami rozdílné polarity) 2 000 VAC, 50/60 Hz po dobu 1 min (mezi vstupními a výstupními svorkami a mezi řídicími obvody)		
Impulsní zkušební napětí	3 kV (mezi napájecími svorkami) pro 100 až 240 VAC / 100 až 125 VDC, 1kV pro 24 až 48 VAC / 12 až 48 VDC 4,5 kV (mezi proud vedoucí svorkou a vystavenými proud nevedoucími kovovými částmi) pro 100 až 240 VAC / 100 až 125 VDC, 1.5 kV pro 24 až 48 VAC / 12 až 48 VDC		
Odolnost proti rušení	±1,5 kV (mezi napájecími svorkami) ±600 V (mezi beznapěťovými vstupními svorkami), impuls obdélníkového průběhu z generátoru rušení (šířka pulsu: 100 nsec/ 1µsec, nárůst 1 nsec)		
Odolnost proti statické elektřině	Porucha: 8 kV Zničení: 15 kV		
Odolnost proti chvění	Zničení: 10 až 55 Hz, 0,75 mm jednoduchá amplituda v každém ze tří směrů Porucha: 10 až 55 Hz, 0,5 mm jednoduchá amplituda v každém ze tří směrů		
Odolnost proti rázům	Zničení: 1 000m/s ² 3x v každém ze 6 směrů Porucha: 100m/s ² 3x v každém ze 6 směrů		
Okolní teplota	Pracovní: -10°C až 55°C (bez námrazy) Skladovací: -25°C až 65°C (bez námrazy)		
Okolní vlhkost	Pracovní: 35% až 85%		
EMC (Vf vlastnosti)	(EMI): EN50081-2 Vyzářování pouzdra: EN55011 Skupina 1 Třída A Vyzářování AC sítě: EN55011 Skupina 1 Třída A (EMS): EN50082-2 Odolnost ESD: EN61000-4-2: 4 kV povrchový výboj 8 kV vzdušný výboj Odolnost proti vf rušení: ENV50140: 10 V/m (amplitudová modulace, 80 MHz až 1 GHz) 10 V/m (pulsní modulace, 900±5 MHz) Odolnost proti přivedeným poruchám: ENV50141 : 10 V (0,15 až 80 MHz) Odolnost proti výbojům: EN61000-4-4: 2 kV napájecí vedení 2 kV signální vedení		
Barva pouzdra	Světle šedá (Munsell 5Y7/1)		
Krytí	IP 40 (čelní panel)		
Hmotnost	Přibližně 90 g		

■ Jmenovité hodnoty

Jmenovité napájecí napětí	100 až 240 VAC (50/60 Hz)/100 až 125 VDC, 24 až 48 VAC (50/60 Hz) / 12 až 48VDC (24 až 48 VAC/VDC pro model H3CR-A8E)
Rozsah pracovních napětí	85% AŽ 110% jmenovitého napájecího napětí (90% až 110% při napájení 12VDC)
Výpadek napájení	min. 0.1 sec
Vstup	<p><u>Beznapěťový vstup:</u> ON impedance: 1 kOhm max. ON zbytkové napětí: 1 V max. OFF impedance: 100 kOhmů min.</p> <p><u>Napěťový vstup:</u> Max. povolený kapacitní odpor mezi vstupy (svorky 6 a 7 nebo 6 a 8): 1 200 pF</p> <ul style="list-style-type: none"> 100 až 240 VAC / 100 až 125 VDC „1“: 85 až 264 VAC / 85 až 137.5 VDC „0“: 0 až 10VAC / 0 až 1.2 VDC 24 až 48 VAC / 12 až 48 VDC „1“: 20.4 až 52.8 VAC / 10.8 až 52.8 VDC „0“: 0 až 2.4 VAC / 0 až 1.2 VDC
Spotřeba	<p><u>H3CR-A/-A8</u></p> <ul style="list-style-type: none"> 100 až 240 VAC / 100 až 125 VDC (při napájení 240 VAC, 60Hz) Relé ON: cca 2.1VA (1.6W) Relé OFF: cca 1.3VA (1.1W) 24 až 48 VAC / 12 až 48 VDC (při napájení 24 VDC) Relé ON: cca 0.8W Relé OFF: cca 0.2W <p><u>H3CR-AP</u></p> <ul style="list-style-type: none"> 100 až 240 VAC / 100 až 125 VDC (při napájení 240 VAC, 60Hz) Relé ON: cca 2.5VA (2.2W) Relé OFF: cca 1.8VA (1.7W) 24 až 48 VAC / 12 až 48 VDC (při napájení 24 VDC) Relé ON: cca 0.9W Relé OFF: cca 0.3W <p><u>H3CR-A8E</u></p> <ul style="list-style-type: none"> 100 až 240 VAC / 100 až 125 VDC (při napájení 240 VAC, 60Hz) Relé ON/OFF: cca 2VA (1W) 24 až 48 VAC/VDC (při napájení 24 VDC) Relé ON/OFF: cca 0.9W <p><u>H3CR-AS/-A8S</u></p> <ul style="list-style-type: none"> 24 až 48 VAC / 12 až 48 VDC (při napájení 24 VDC) Výstup ON: cca 0.3W Výstup OFF: cca 0.2W
Výstup	Časový kontakt: 5 A při 250VAC/30VDC, odporová zátěž ($\cos \phi = 1$) Tranzistorový výstup: Otevřený kolektor (NPN/PNP), 100 mA max. při 30 VDC, zbytkové napětí 2 v max. Mžikový kontakt: 5 A při 250 VAC, odporová zátěž ($\cos \phi = 1$)

Názvosloví

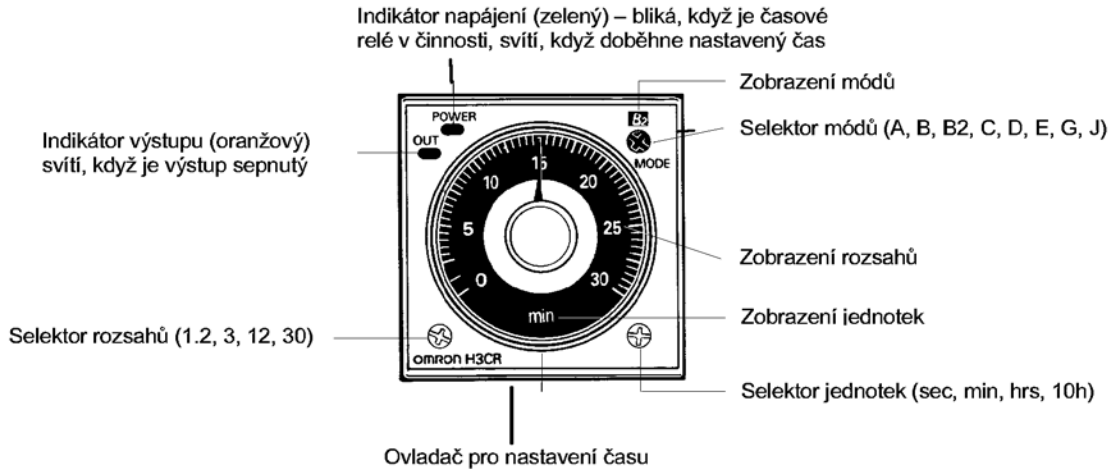

Časové diagramy

H3CR-A/-AS/-AP

Operating mode	Timing chart	
A: ON-delay		<div style="border: 1px solid black; padding: 5px;">Basic operation</div> <p>Note: Start input is invalid while the Timer is in operation.</p>
B: Flicker OFF start		<div style="border: 1px solid black; padding: 5px;">Basic operation</div> <p>Note: Start input is invalid while the Timer is in operation.</p>
B2: Flicker ON start		<div style="border: 1px solid black; padding: 5px;">Basic operation</div> <p>Note: Start input is invalid while the Timer is in operation.</p>
C: Signal ON/OFF-delay		<div style="border: 1px solid black; padding: 5px;">Basic operation</div> <p>Note: Start input is valid and re-triggerable while the Timer is in operation.</p>

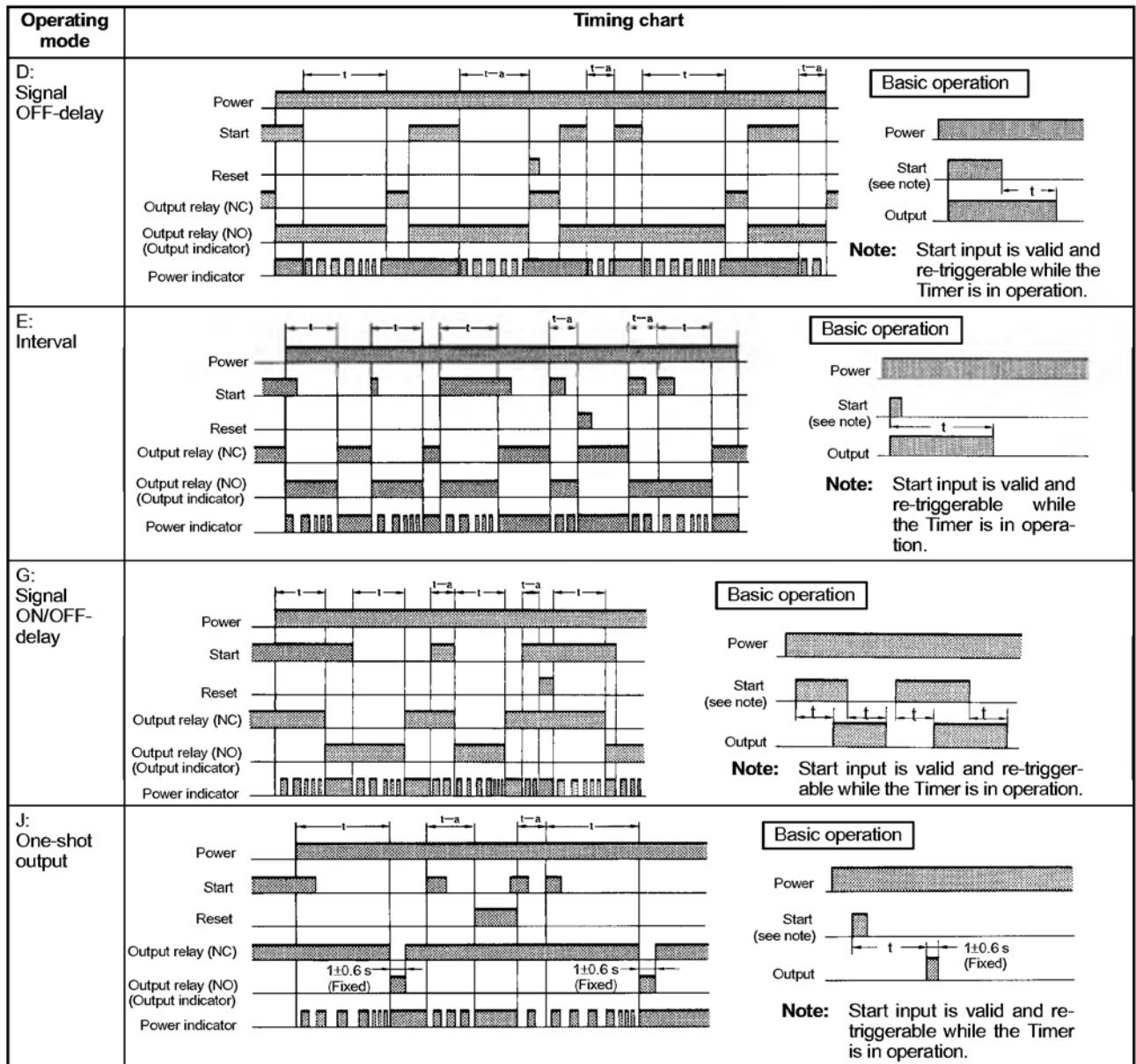

Gate Signal Input

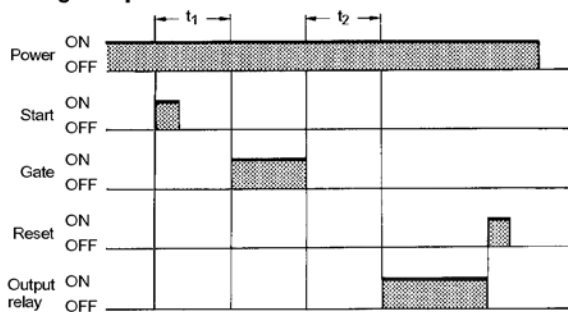

- Note:**
1. This timing chart indicates the gate input in operating mode A (ON-delay operation).
 2. The set time is the sum of t_1 and t_2 .
 3. H3CR-AP model incorporates start input only.

H3CR-A8/-A8S

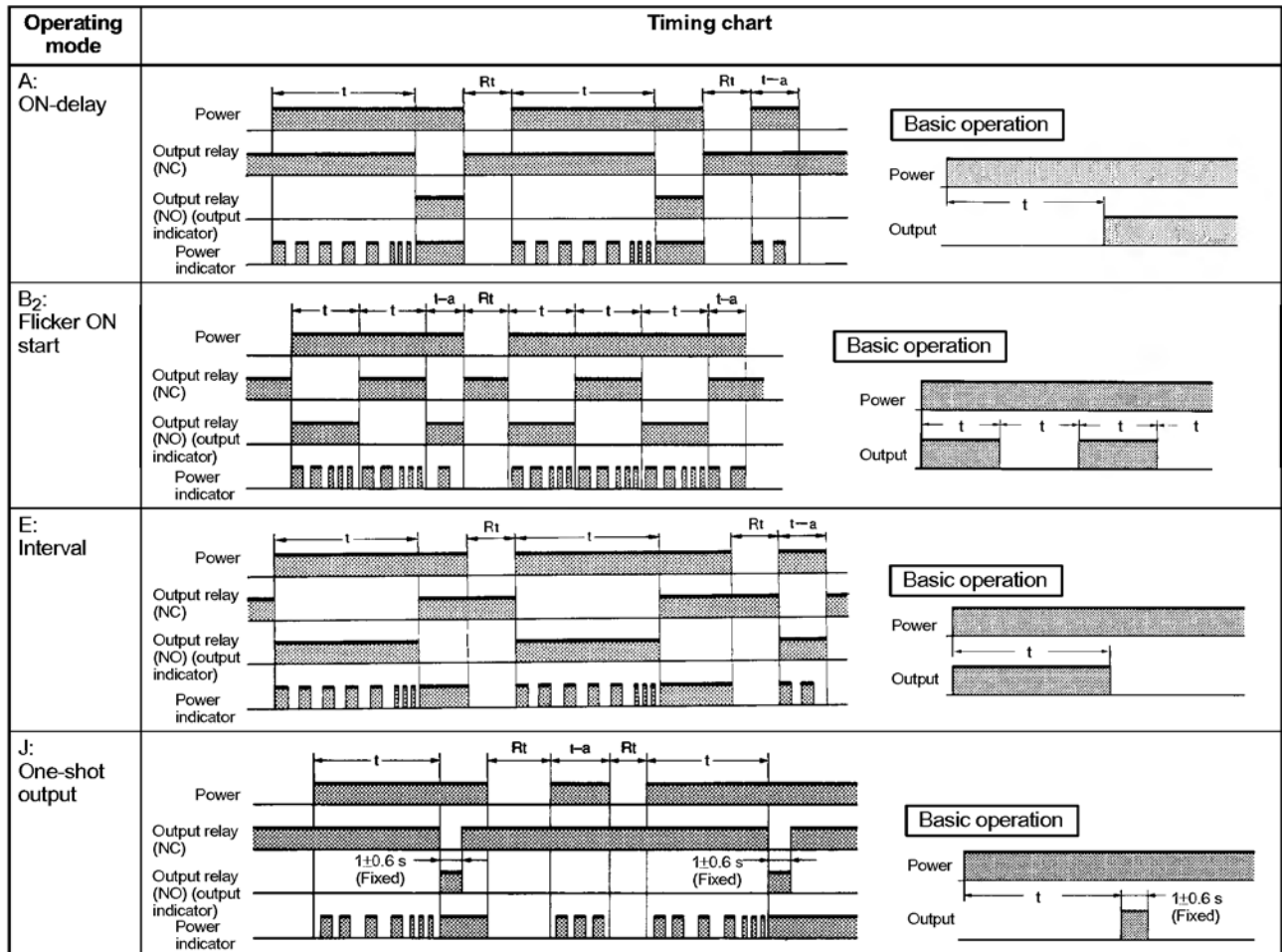

H3CR-A8E

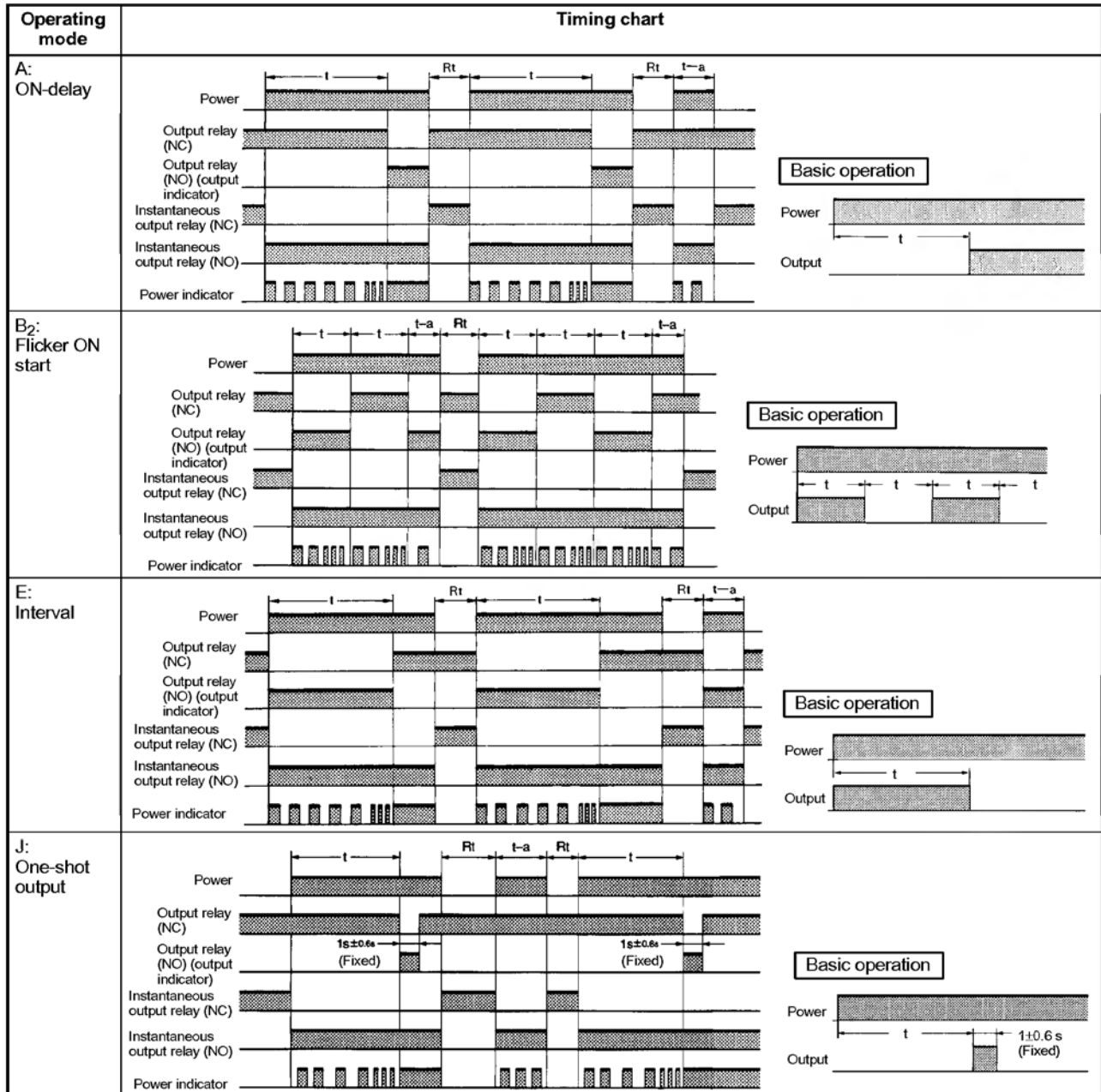

Rozměry

Poznámka: Všechny rozměry jsou v milimetrech, pokud není uvedeno jinak.

■ Rozměry přístrojů

H3CR-A
H3CR-AP
H3CR-AS

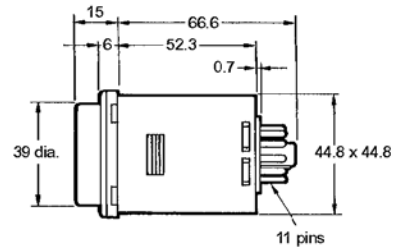
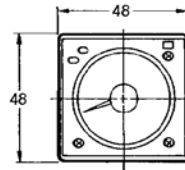
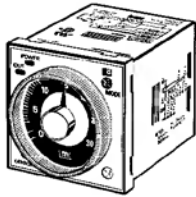

H3CR-A8
H3CR-A8S
H3CR-A8E

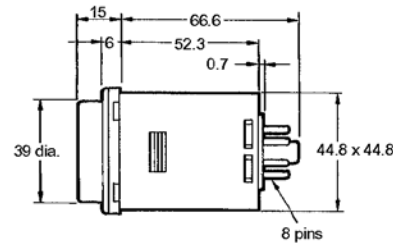
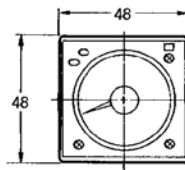
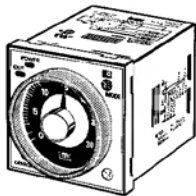

Dimensions with Set Ring

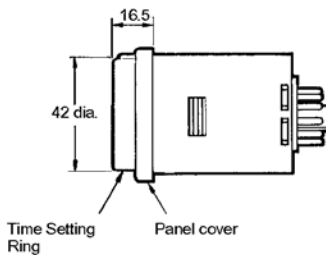
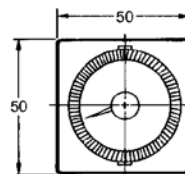

Dimensions with Front Connecting Socket P2CF-08- /P2CF-11-

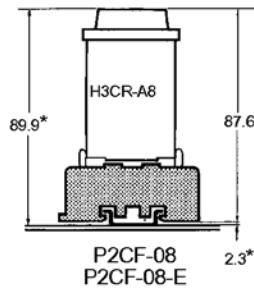
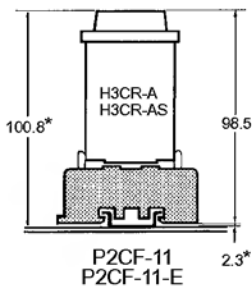

Dimensions with Back Connecting Socket P3G-08/P3GA-11

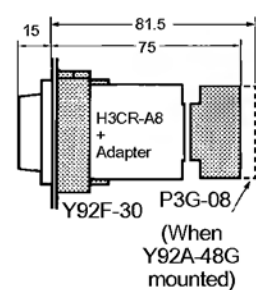
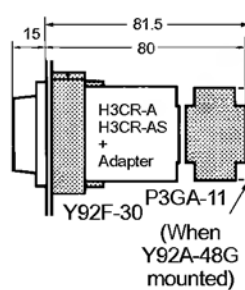

*These dimensions vary with the kind of DIN track (reference value).

■ Rozměry při montáži do panelu

Flush Mounting Adaptor

Y92F-30

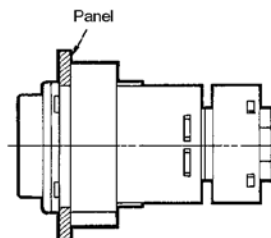
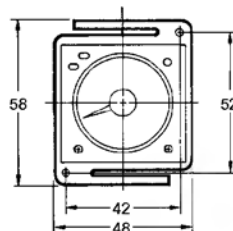
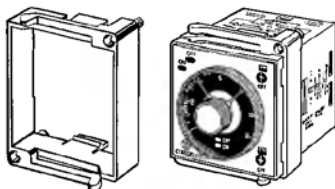

■ Rozměry patic a příslušenství

Track Mounting/Front Connecting Socket

P2CF-08

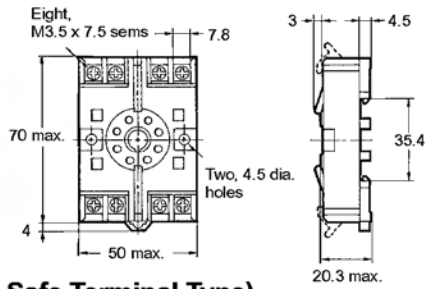
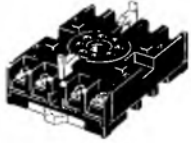

**Terminal Arrangement/
Internal Connections
(Top View)**

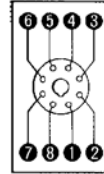

Surface Mounting Holes

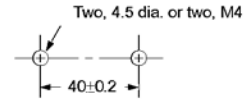

P2CF-08-E (Finger Safe Terminal Type)

Conforming to VDE0106/P100

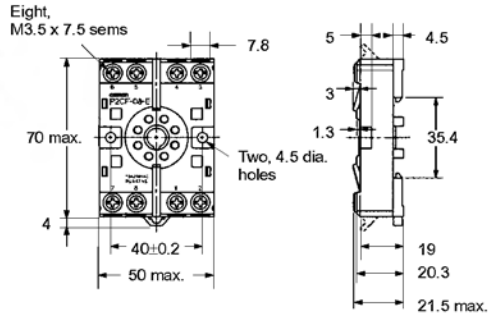
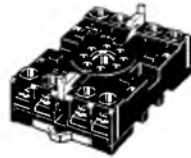

**Terminal Arrangement/
Internal Connections
(Top View)**

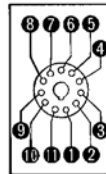

Surface Mounting Holes

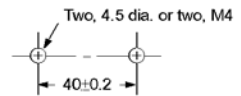

Track Mounting/Front Connecting Socket

P2CF-11

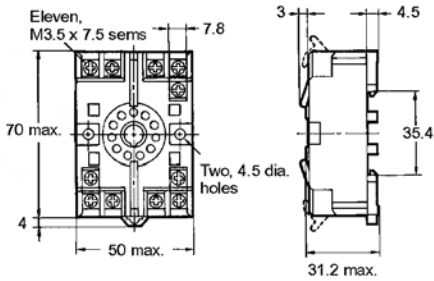

**Terminal Arrangement/
Internal Connections
(Top View)**

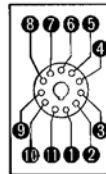

Surface Mounting Holes

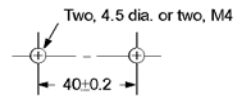

P2CF-11-E (Finger Safe Terminal Type)

Conforming to VDE0106/P100

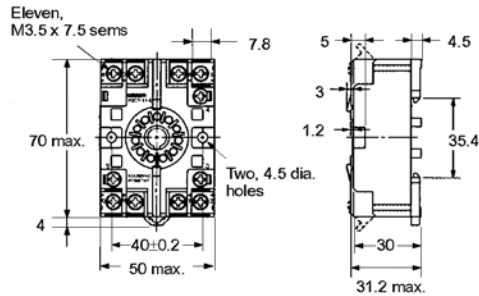
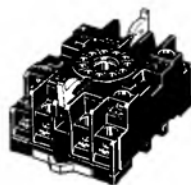

Back Connecting Socket

P3G-08

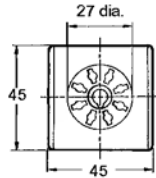
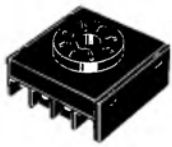

**Terminal Arrangement/
Internal Connections
(Bottom View)**

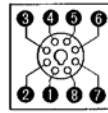

P3GA-11

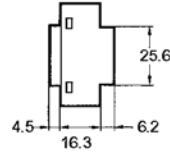
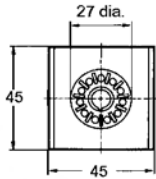

**Terminal Arrangement/
Internal Connections
(Bottom View)**

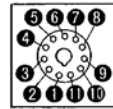

Finger Safe Terminal Cover

Conforming to VDE0106/P100

Y92A-48G

(Attachment for P3G-08/P3GA-11 Socket)

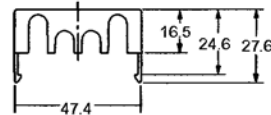
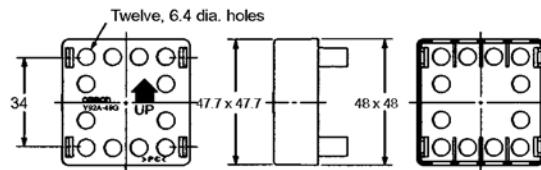
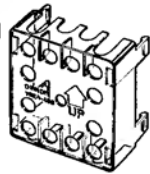

Mounting Track

PFP-100N, PFP-50N

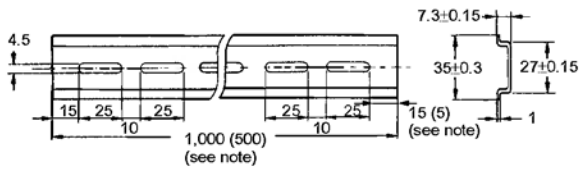

PFP-100N2

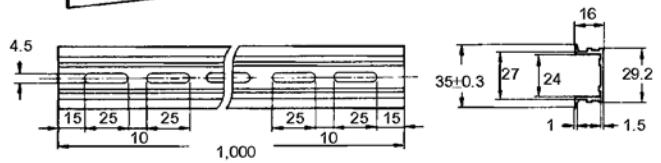

Note: The value shown in parentheses are for the PFP-50N.

End Plate

PFP-M

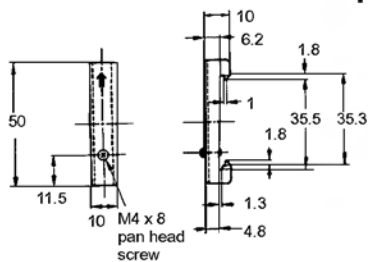
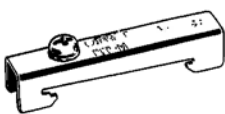

Spacer

PFP-S

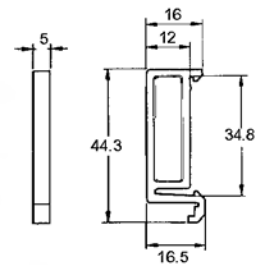

■ Kryty

Y92A-48B



Ochranný kryt čelního panelu z pevného plexiskla.
Ochranný kryt používejte pouze s montážním
rámečkem Y92F-30. S rámečky Y92F-73 a Y92F-74
nelze použít.

Y92S-27
Time Setting A



Y92S-28
Time Setting B



Y92S-28
Time Setting C



Y92P-48GL
Light Gray

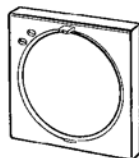

Y92P-48GB
Black

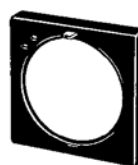

Y92P-48GM
Medium Gray

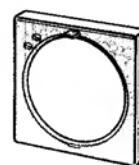

Instalace

■ Uspořádání kontaktů

11-pin Models

H3CR-A (Contact Output)

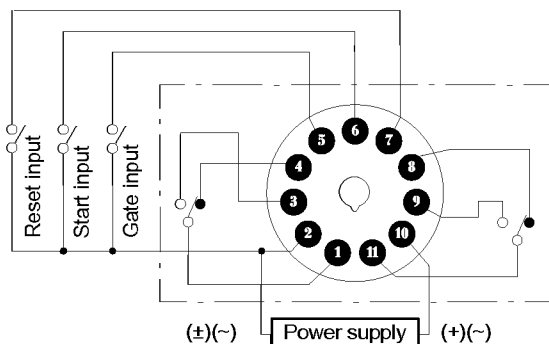

H3CR-AS (Transistor Output)

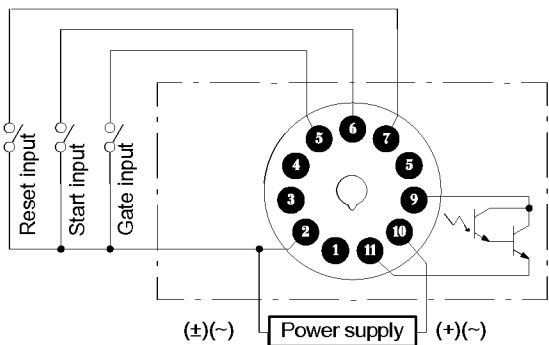

Note: Terminals 1, 3, 4, and 8 are empty. Terminals 2, 5, 6, 7, and 10 are the same as for the H3CR-A.

H3CR-AP (Contact Output)

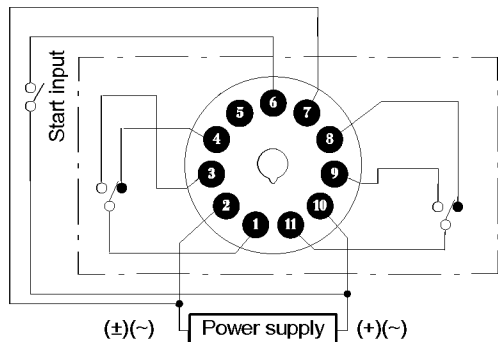

Note: Terminal 5 is empty.

8-pin Models

H3CR-A8 (Contact Output)

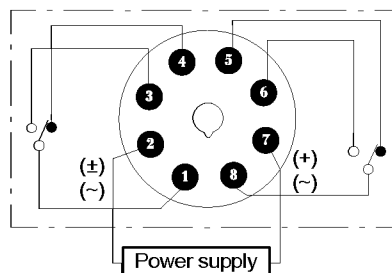

H3CR-A8S (Transistor Output)

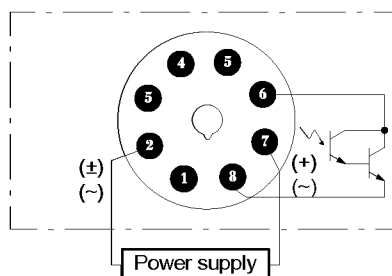

Note: Terminals 1, 3, 4, and 5 are empty. Terminals 2 and 7 are the same as for the H3CR-A8.

H3CR-A8E (Contact Output)

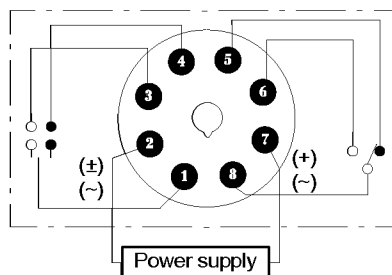

■ Vstupní obvody

H3CR-A/-AS

The inputs of the H3CR-A/-AS are no-voltage (short-circuit or open) inputs.

No-voltage Inputs

No-contact Input
(Connection to NPN open collector output sensor.)

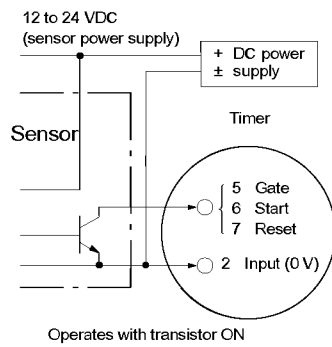

Contact Input

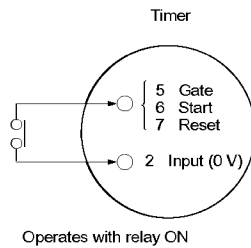

No-contact Input
(Connection to a voltage output sensor.)

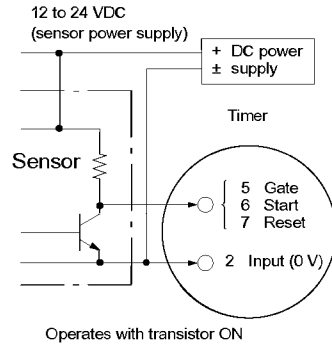

H3CR-AP

The start input of the H3CR-AP is voltage input. (Voltage imposition or open)

Voltage Inputs

No-contact Input
(Connection to PNP open collector output sensor)

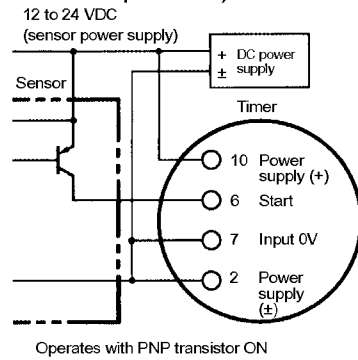

No-contact Input
(Connection to NPN open collector output sensor)

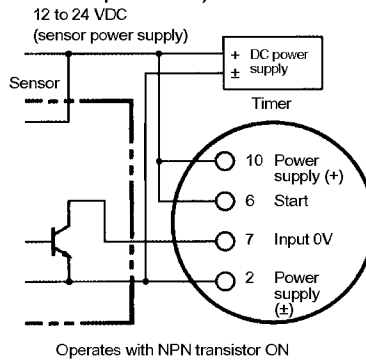

Contact Input

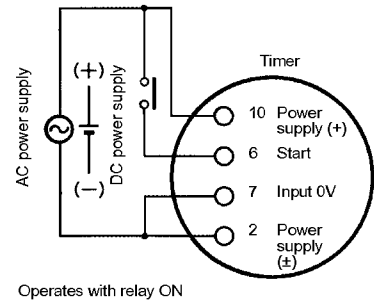

Note: The input circuit is isolated from the power supply circuit. Thus, an NPN transistor can be connected.

Note: Refer to the signal levels in the following table and be aware of the minimum applicable load of the relay.

Další nabízené modely z řady analogových časových relé H3CR

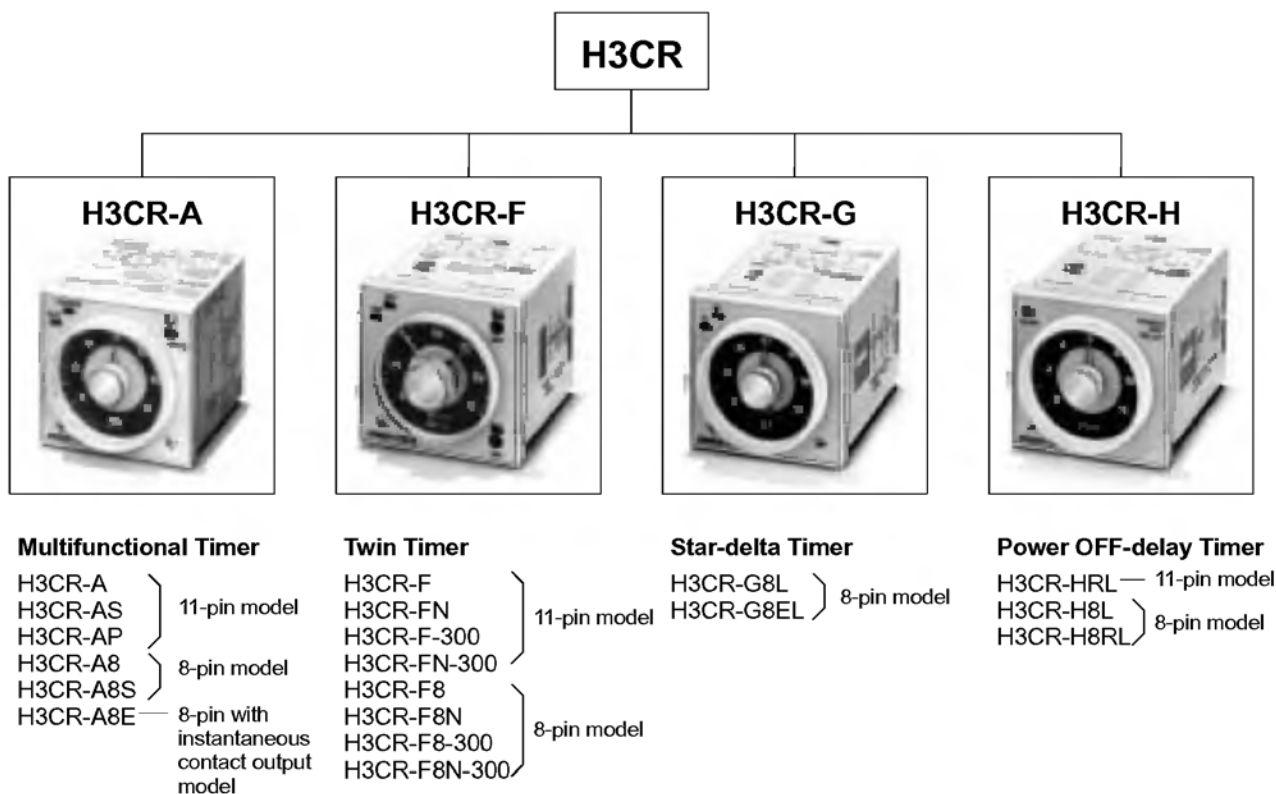

Note: H3CR-AS, H3CR-A8S: Transistor output models

VŠECHNY ROZMĚRY JSOU V MILIMETRECH

Pro převod milimetrů na palce násobte 0,03937. Pro převod gramů na unce násobte 0,03527.

Katalogové číslo L084-E1-1C

V zájmu vylepšení výrobku změny vyhrazeny.

OMRON Corporation

Measuring and Supervisory Controls Division
28th Fl., Crystal Tower Bldg.,
1-2-27, Shiomi, Chuo-ku,
Osaka 540-6028 Japan
Phone: (81)6-6949-6035 Fax: (81)6-6949-6069

OMRON Electronics spol. s r.o.

Šrobárova 6
101 00 PRAHA 10
Tel.: 02-7173 1319, 7173 4687, 7173 7452
6731 1254
Fax: 02-7173 5613
<http://www.omron.cz>

DIN Track Mounted, Standard 17.5-mm Width Timer Range

- A wide AC/DC power supply range (24 to 230 VAC/ 24 to 48 VDC) reduces the number of timer models kept in stock. (24 to 230 VAC/VDC with H3DS-XL□)
- Smart Dial/Selector-locking Mechanism: Prevents the dials and selectors on the Timer's front panel from being inadvertently operated or being operated without authorization. The lock can only be unlocked and locked with an optional pen-type Lock Key.
- Screw-Less Clamp type available. (H3DS-□LC)
- Sticker provided for easy timer identification and management.
- Terminal clamp left open when delivered (screw terminal type).
- Finger protection terminal block to meet VDE0106/P100.
- Enables easy sequence checks through instantaneous outputs for a zero set value at any time range.
- Incorporates environment-friendly, cadmium-free contacts.
- Conforms to EN61812-1 and IEC60664-1 (VDE0110) 4 kV/2 for Low Voltage and EMC Directives.
- **Broad Line-up of H3DS Series**

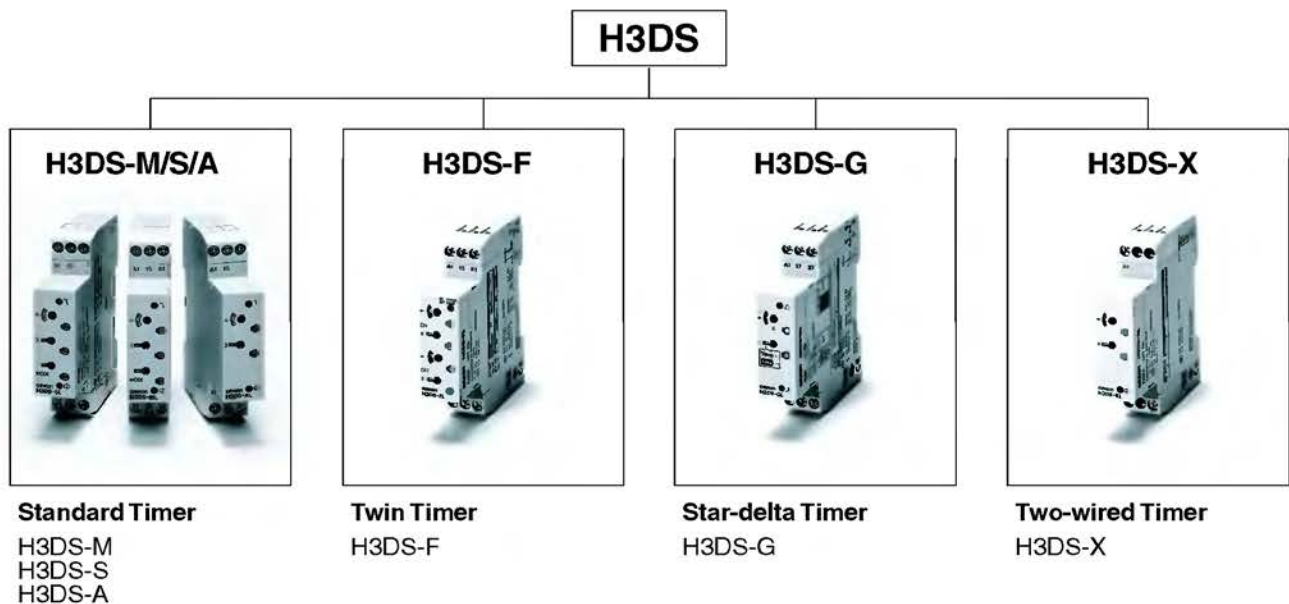

Contents

Solid-state Timer

H3DS-M/S/A	5
H3DS-F	15
H3DS-G	21
H3DS-X	27

Common to ALL Timers

Installation of Screw-Less Clamp Models	33
Accessories	36
Precautions	37

- Eight operating modes (H3DS-M) and four operating modes (H3DS-S) cover a wide range of applications.
- A wide time setting range of 0.10 s to 120 h.
- Two LEDs indicate power and relay status respectively.



Ordering Information

Supply voltage	Control output	Input type	Operating mode (see note)	Model	
				Screw terminal type	Screw-Less Clamp type
24 to 230 VAC (50/60Hz)/ 24 to 48 VDC	Contact output: SPDT (time-limit output SP-DT)	Voltage input	Eight multi-modes: A, B, B2, C, D, E, G, J	H3DS-ML	H3DS-MLC
		No-input available	Four multi-modes: A, B2, E, J	H3DS-SL	H3DS-SLC
			Single mode: A	H3DS-AL	H3DS-ALC

Note: The operating modes are as follows:

- A: ON-delay
- B: Flicker OFF start
- B2: Flicker ON start
- C: Signal ON/OFF-delay
- D: Signal OFF-delay
- E: Interval
- G: Signal ON/OFF-delay
- J: One shot

Model Number Legend

H3DS - L
 1 2 3

1. M: Multi-function type
S: Standard type
A: Single-function type
2. L: Smart lock mechanism
3. None: Screw terminal type
C: Screw-Less Clamp type

Accessories (Order Separately)

Lock Key		Y92S-38
Mounting Track	50 cm (l) x 7.3 mm (t)	PFP-50N
	1 m (l) x 7.3 mm (t)	PFP-100N
	1 m (l) x 16 mm (t)	PFP-100N2
End Plate		PFP-M
Spacer		PEP-S

Specifications

■ General

Item	H3DS-ML□	H3DS-SL□	H3DS-AL□
Operating mode	A: ON-delay (Signal or Power) B: Flicker OFF start (Signal or Power) B2: Flicker ON start (Signal or Power) C: Signal ON/OFF-delay D: Signal OFF-delay E: Interval (Signal or Power) G: Signal ON/OFF-delay J: One-shot (Signal or Power)	A: ON-delay B2: Flicker ON start E: Interval J: One-shot	A: ON-delay (fixed)
Input type	Voltage input	---	
Output type	Relay: SPDT		
External connections	Screw terminal, Screw-Less Clamp		
Terminal block	Screw terminal type: Clamps two 2.5-mm ² max. bar terminals without sleeves. Screw-Less Clamp type: Clamps two 1.5-mm ² max. bar terminals without sleeves.		
Terminal screw tightening torque	0.98 N • m max.		
Mounting method	DIN track mounting (see note)		
Attachment	Nameplate label		
Approved standards	UL508, CSA C22.2 No.14 Conforms to EN61812-1, IEC60664-1 (VDE0110) 4 kV/2, VDE0106/P100 Output category according to IEC60947-5-1 (AC-13; 250 V 5 A/AC-14; 250 V 1 A/AC-15; 250 V 1 A/DC-13; 30 V 0.1 A/DC-14; 30 V 0.05 A)		

Note: Can be mounted to 35-mm DIN Track with a plate thickness of 1 to 2.5 mm.

■ Time Ranges

Time scale display	Time range
0.1 s	0.1 to 1.2 s
1 s	1 to 12 s
0.1 m	0.1 to 1.2 min
1 m	1 to 12 min
0.1 h	0.1 to 1.2 h
1 h	1 to 12 h
10 h	10 to 120 h

Note: When the time setting dial is set to "0" for any time scale, the output will operate instantaneously.

■ Ratings

Rated supply voltage (see notes 1 and 2)	24 to 230 VAC (50/60 Hz)/24 to 48 VDC
Operating voltage range	85% to 110% of rated supply voltage
Power reset	Minimum power-off time: 0.1 s
Reset voltage	2.4 VAC/DC max.
Power consumption (see note 3)	AC: 32 VA max./3.0 W max. (typical: 30 VA/2.7 W) at 230 VAC 14 VA max./2.2 W max. (typical: 13 VA/2.1 W) at 100 to 120 VAC DC: 0.7 W max. (typical: 0.6 W) at 24 VDC 1.4 W max. (typical: 1.3 W) at 48 VDC
Voltage input	Max. permissible capacitance between inputs lines (terminals B1 and A2): 2,000 pF Load connectable in parallel with inputs (terminals B1 and A1). H-level: 20.4 to 253 VAC/20.4 to 52.8 VDC L-level: 0 to 2.4 VAC/DC
Control output	Contact output: 5 A at 250 VAC with resistive load ($\cos\phi = 1$) 5 A at 30 VDC with resistive load ($\cos\phi = 1$)
Ambient temperature	Operating: -10°C to 55°C (with no icing) Storage: -25°C to 65°C (with no icing)
Ambient humidity	Operating: 35% to 85%

Note: 1. DC ripple rate: 20% max.

2. Since an inrush current of 0.4 A will occur when using the power supply voltage at 24 VDC, pay careful attention when turning on or off the power supply to the Timer with a solid-state output such as a sensor.

3. The power consumption is for mode A after the Timer counts the time-up time and for the AC input at 50 Hz. The power consumption of the H3DS-ML includes the input circuit with the B1 and A1 terminals short-circuited.

■ Characteristics

Accuracy of operating time	±1% max. of FS (±1% ±10 ms max. at 1.2-s range)
Setting error	±10% ±50 ms max. of FS
Signal input time	50 ms min.
Influence of voltage	±0.7% max. of FS (±0.7% ±10 ms max. at 1.2-s range)
Influence of temperature	±5% max. of FS (±5% ±10 ms max. at 1.2-s range)
Insulation resistance	100 MΩ min. at 500 VDC
Dielectric strength	Between current-carrying metal parts and exposed non-current-carrying metal parts: 2,000 VAC for 1 min. Between control output terminals and operating circuit: 2,000 VAC for 1 min. Between contacts not located next to each other: 1,000 VAC for 1 min.
Vibration resistance	Malfunction: 0.5-mm single amplitude at 10 to 55 Hz Destruction: 0.75-mm single amplitude at 10 to 55 Hz
Shock resistance	Malfunction: 100 m/s ² 3 times each in 6 directions Destruction: 1,000 m/s ² 3 times each in 6 directions
Impulse withstand voltage	3 kV (between power terminals) 4.5 kV (between current-carrying metal parts and exposed non-current-carrying metal parts)
Noise immunity	Square-wave noise generated by noise simulator (pulse width: 100 ns/1 μs, 1-ns rise) ±1.5 kV
Static immunity	Malfunction: 4 kV Destruction: 8 kV
Life expectancy	Mechanical: 10 million operations min. (under no load at 1,800 operations/h) Electrical: 100,000 operations min. (5 A at 250 VAC, resistive load at 360 operations/h) (see note)
EMC	(EMI) EN61812-1 Emission Enclosure: EN55011 Group 1 class B Emission AC Mains: EN55011 Group 1 class B Harmonic Current: EN61000-3-2 Voltage Fluctuation and Flickering: EN61000-3-3 (EMS) EN61812-1 Immunity ESD: EN61000-4-2: 6 kV contact discharge (level 3) 8 kV air discharge (level 3) Immunity RF-interference from AM Radio Waves: EN61000-4-3: 10 V/m (80 MHz to 1 GHz) (level 3) Immunity Burst: EN61000-4-4: 2 kV power port and output port (level 3) 1 kV control port with capacitive clamp (level 3) Immunity Surge: EN61000-4-5: 2 kV common mode (level 3) 1 kV differential mode (level 3)
Case color	Light gray (5Y7/1)
Degree of protection	IP30 (Terminal block: IP20)
Weight	Approx. 70 g

Note: For reference:

A maximum current of 0.15 A can be switched at 125 VDC (cosφ=1).

A maximum current of 0.1 A can be switched if L/R is 7 ms.

In both cases, a life of 100,000 operations can be expected.

The minimum applicable load is 10 mA at 5 VDC (failure level: P).

Nomenclature

H3DS-ML□/SL□

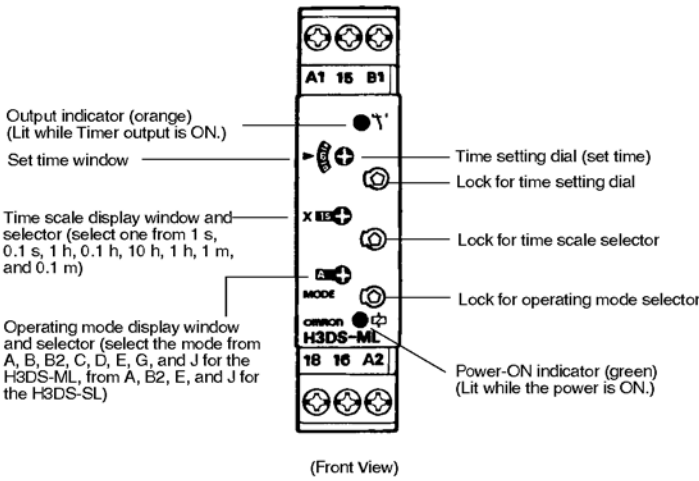

H3DS-MLC/SLC

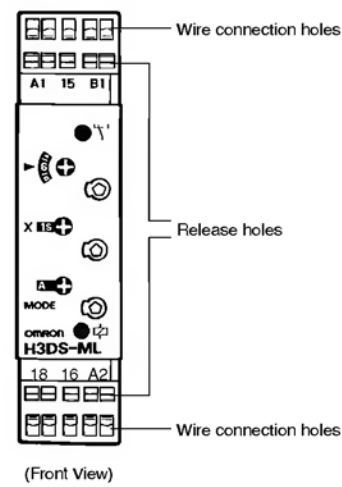

H3DS-AL□

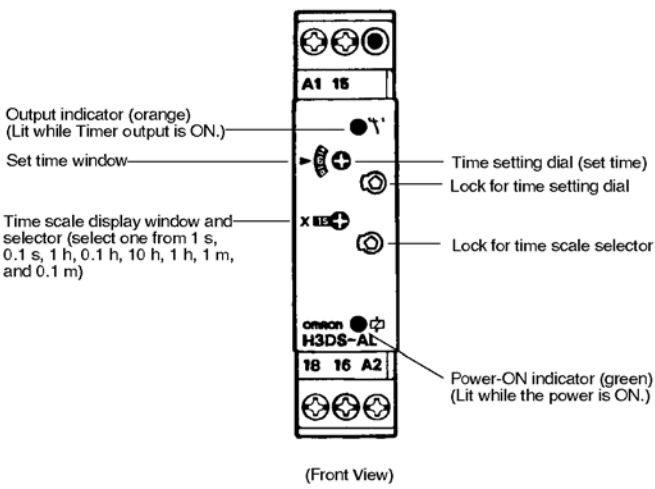

H3DS-ALC

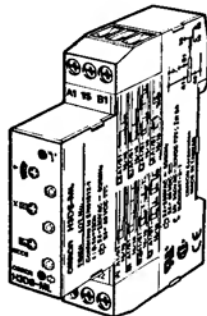
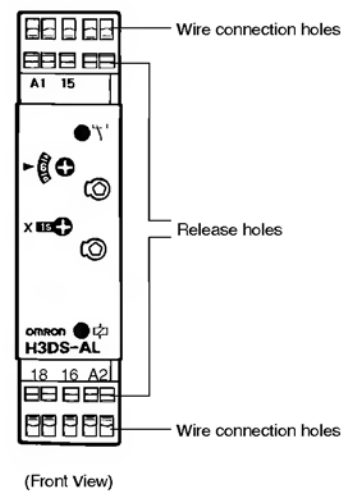

Attach the enclosed label here as a nameplate.
(The label is attached to the Timer's DIN Track hook section at the time of shipment.)

Operation

■ Block Diagram

H3DS-ML□

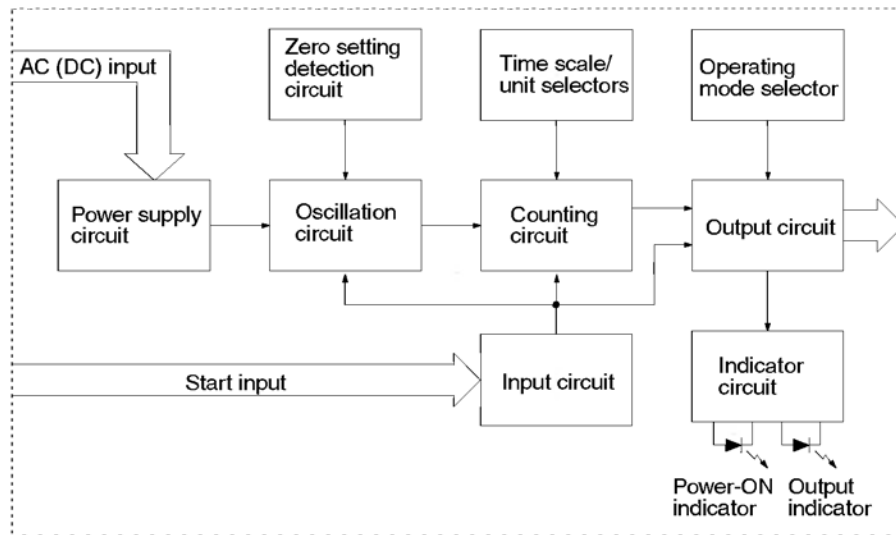

H3DS-SL□/-AL□

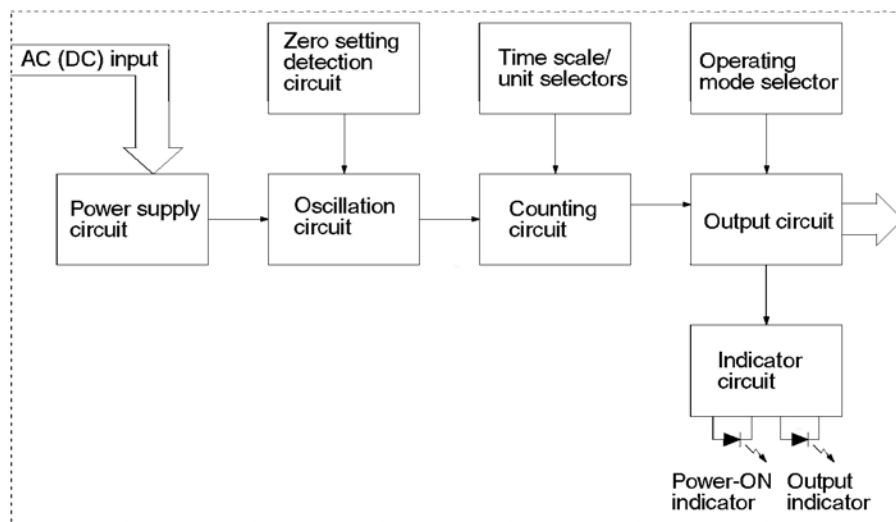

■ I/O Functions

Item		H3DS-ML□	H3DS-SL□/-AL□
Input	Start	Starts operation.	No input is available.
Output	Control output	Outputs are turned ON according to designated output mode when preset value is reached.	Outputs are turned ON according to designated output mode when preset value is reached.

■ Basic Operation

Setting of Selector

The selectors can be turned clockwise and counterclockwise to select the desired time scale, or operating mode.

Each selector has a snap mechanism that secures the selector at a given position. Set the selector at a position at which it is secured. Do not set it midway between two securing positions or a malfunction could result from improper setting.

Selection of Operating Mode (except for H3DS-AL)

The H3DS-ML/-SL can be set to any one of the operating modes A to J. Turn the operating mode selector with a screwdriver until the desired operating mode appears in the operating mode display window.

H3DS-ML (8 modes): A, B, B2, C, D, E, G, J
(In order of appearance)

H3DS-SL (4 modes): A, E, B2, J, E, E, J, J
(In order of appearance)

Note: Letters that appear more than once indicate exactly the same operating mode.

Selection of Time Scale

The time scale is selected by turning the time scale selector. The time scales will appear in the following order in the time scale display window on the left of the selector:

1 s, 0.1 s, 1 h, 0.1 h, 10 h, 1 h, 1 m, 0.1 m.

Note: The time scale "1h" appears twice. Both instances indicate exactly the same time scale.

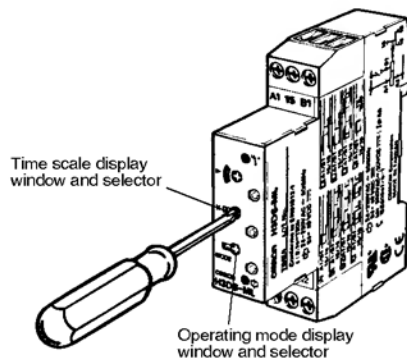

Locking/Unlocking of Selectors and Time Setting Dial

The time setting dial, time scale selector, and operating mode selector can be locked using the Y92S-38 Lock Key, a special pen type tool that is sold separately. To lock the dial or selectors, insert the Lock Key in the keyhole to the lower right of the dial or selector and turn it clockwise until the dial or selector is completely covered with the red cover. To unlock, turn the Lock Key in the opposite direction.

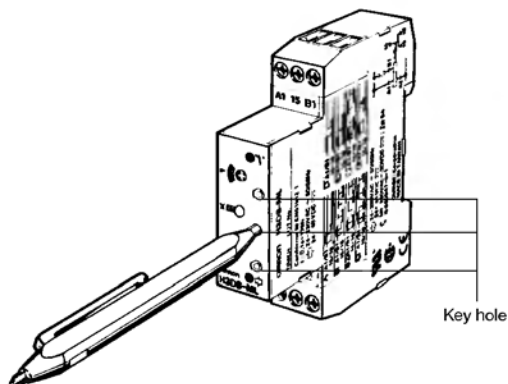

■ Timing Chart

- Note:**
1. The minimum power reset time is 0.1 s and the minimum signal input time is 0.05 s.
 2. The letter "t" in the timing charts stands for the set time and "t-a" means that the period is less than the time set.
 3. There is no start input for H3DS-SL□ models. Operation starts at power-on.

Operating mode	Timing chart	
A: ON-delay		<p>Basic operation</p> <p>* For power-on operation, impose voltage to the Start input. The Timer starts operating at the moment the power is turned on. ** Start input is invalid while the Timer is in operation.</p>
B: Flicker OFF start		<p>Basic operation</p> <p>* For power-on operation, impose voltage to the Start input. The Timer starts operating at the moment the power is turned on. ** Start input is invalid while the Timer is in operation.</p>
B2: Flicker ON start		<p>Basic operation</p> <p>* For power-on operation, impose voltage to the Start input. The Timer starts operating at the moment the power is turned on. ** Start input is invalid while the Timer is in operation.</p>
C: Signal ON/OFF-delay		<p>Basic operation</p> <p>* Start input is invalid while the Timer is in operation.</p>

Note: The start input of the H3DS-ML□ model is activated by applying a voltage to B1 and A2 terminals. The voltage can be applied by turning on the contact between B1 and A1 (Refer to *Terminal Arrangement*).

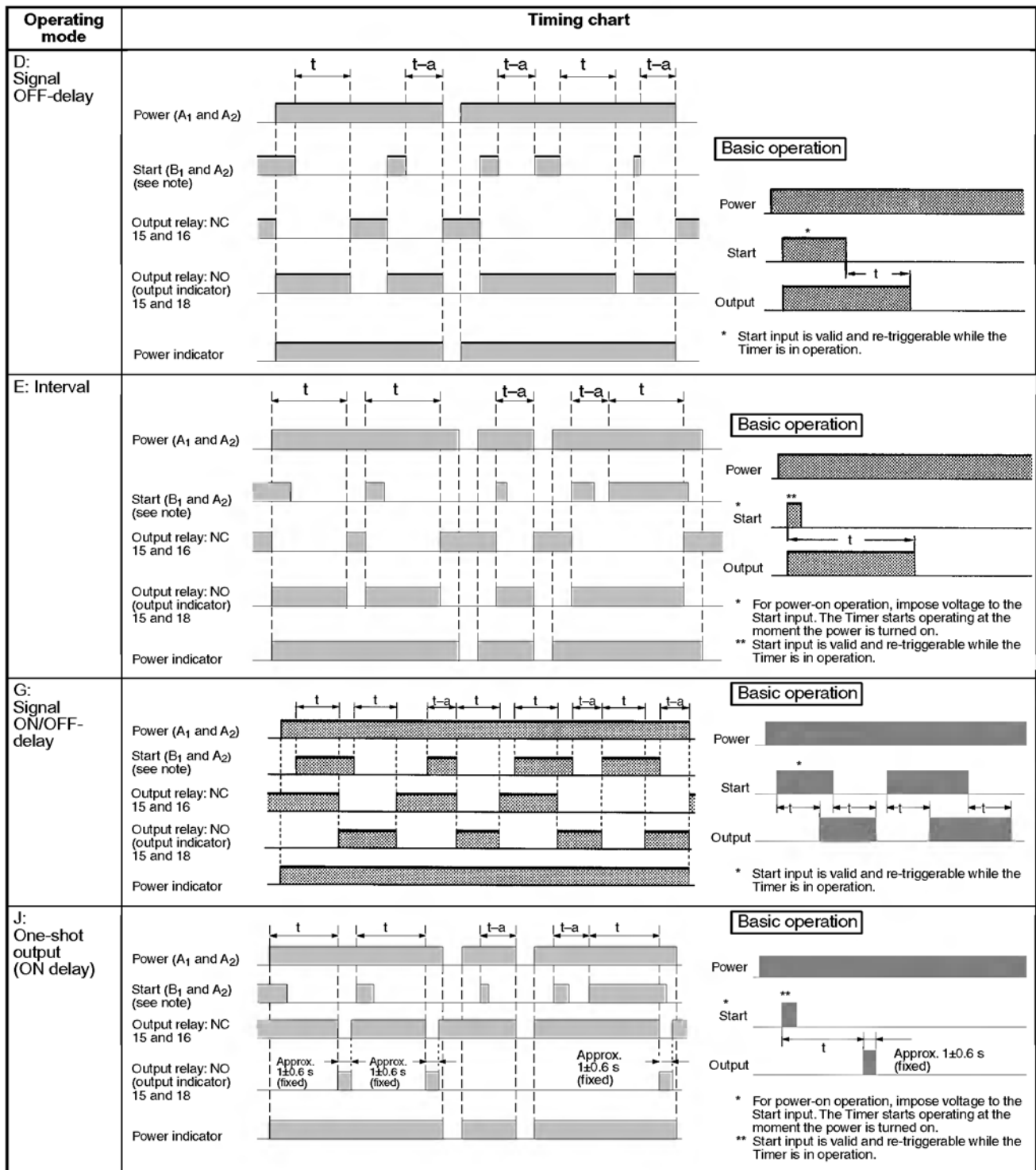

Note: The start input of the H3DS-ML□ model is activated by applying a voltage to B1 and A2 terminals. The voltage can be applied by turning on the contact between B1 and A1 (Refer to *Terminal Arrangement*).

Dimensions

Note: All units are in millimeters unless otherwise indicated.

H3DS-ML/-SL/-AL

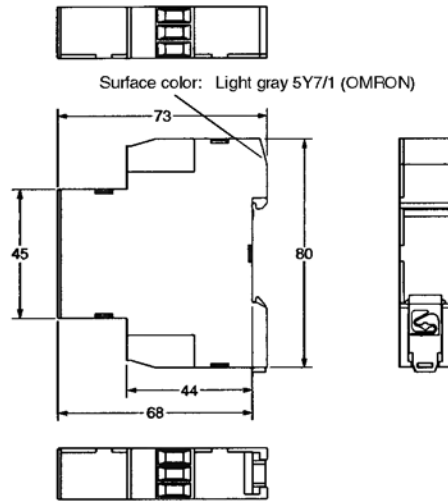
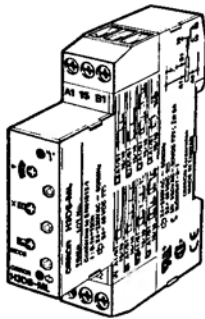

H3DS-MLC/-SLC/-ALC

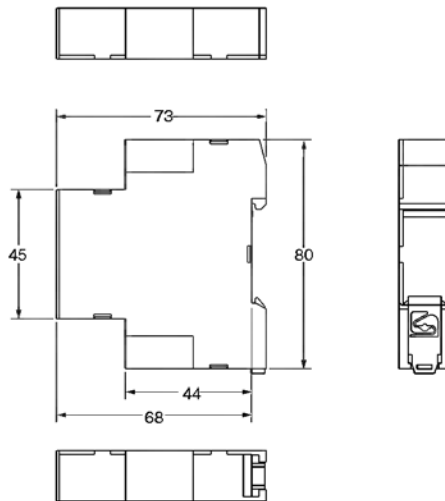
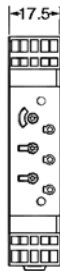
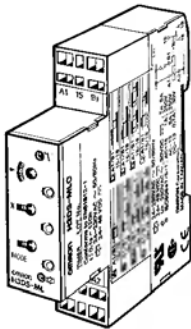

Installation

Terminal Arrangement

H3DS-MLC

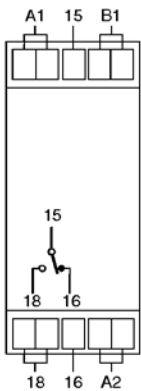

H3DS-ML

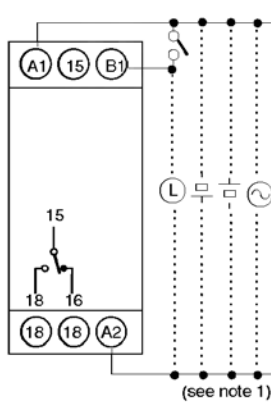

H3DS-SLC/-ALC

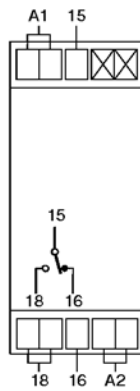

H3DS-SL/-AL

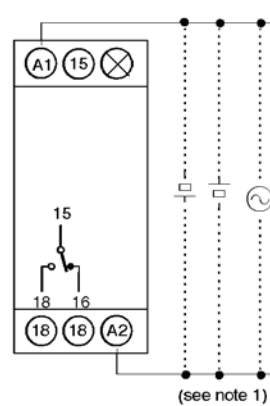

Note: 1. DC supply voltage does not require the designation of polarity.

2. The contact symbol for the H3DS is indicated with  because it offers multiple operating modes and is different from the delayed contact for conventional timers.

■ Input Connections

The inputs of the H3DS-ML□ are voltage (voltage imposition or open) inputs.

No-contact Input (Connection to PNP output sensor.)

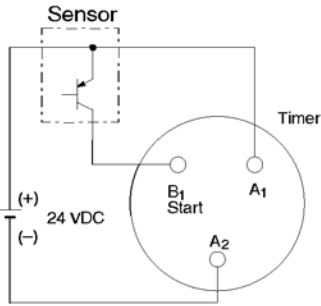

Operates with PNP transistor ON

No-contact Input (Connection to NPN output sensor.)

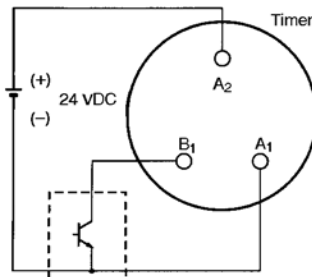

Operates with NPN transistor ON

Contact Input

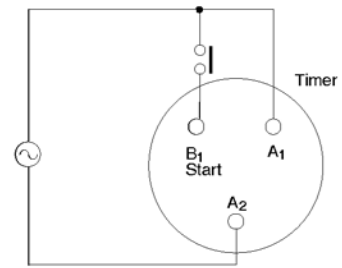

Operates with relay ON

Voltage Input Signal Levels

No-contact input	1. Transistor ON Residual voltage: 1 V max. (Voltage between terminals B ₁ and A ₂ must be more than the rated "H-level" voltage (20.4 VDC min.).)
	2. Transistor OFF Leakage current: 0.01 mA max. (Voltage between terminals B ₁ and A ₂ must be less than the rated "L-level" voltage (2.4 VDC max.).)
Contact input	Use contacts that can adequately switch 0.1 mA at each voltage to be imposed. (When the contacts are ON or OFF, voltage between terminals B ₁ and A ₂ must be within the following ranges: When contacts are ON: 20.4 to 253 VAC/20.4 to 52.8 VDC When contacts are OFF: 0 to 2.4 VAC/DC)

- Operates in flicker-OFF or flicker-ON start mode with one Unit.
- Independent ON- and OFF-time settings. Combinations of long ON- or OFF-time and short OFF- or ON-time setting are possible.
- Long time range from 0.1 s to 12 h for both ON and OFF time settings.



Ordering Information

Operating mode	Supply voltage	Model	
		Screw terminal type	Screw-Less Clamp type
Flicker-OFF/Flicker-ON start	24 to 230 VAC (50/60 Hz)/24 to 48 VDC	H3DS-FL	H3DS-FLC

■ Model Number Legend

H3DS -F L
 1 2 3

1. F: Twin timers
2. L: Smart lock mechanism
3. None: Screw terminal type
 C: Screw-Less Clamp type

■ Accessories (Order Separately)

Lock Key		Y92S-38
Mounting Track	50 cm (l) x 7.3 mm (t)	PFP-50N
	1 m (l) x 7.3 mm (t)	PFP-100N
	1 m (l) x 16 mm (t)	PFP-100N2
End Plate		PFP-M
Spacer		PEP-S

Specifications

■ General

Item	H3DS-F
Operating mode	Flicker-OFF/Flicker-ON start
Output type	Relay: SPDT
External connections	Screw terminal, Screw-Less Clamp
Terminal block	Screw terminal type: Clamps two 2.5-mm ² max. bar terminals without sleeves. Screw-Less Clamp type: Clamps two 1.5-mm ² max. bar terminals without sleeves.
Terminal screw tightening torque	0.98 N • m max.
Mounting method	DIN track mounting (see note)
Attachment	Nameplate label
Approved standards	UL508, CSA C22.2 No.14 Conforms to EN61812-1, IEC60664-1 (VDE0110) 4 kV/2, VDE0106/P 100 Output category according to IEC60947-5-1 (AC-13; 250 V 5A/AC-15; 250 V 1 A/DC-13; 30 V 0.1 A)

Note: Can be mounted to 35-mm DIN Track with a plate thickness of 1 to 2.5 mm.

■ Time Ranges

Time scale display	Time range
0.1 s	0.1 to 1.2 s
1 s	1 to 12 s
0.1 m	0.1 to 1.2 min
1 m	1 to 12 min
0.1 h	0.1 to 1.2 h
1 h	1 to 12 h

Note: When the time setting dial is set to "0" for any time scale, the output will operate instantaneously.

■ Ratings

Rated supply voltage (See note.)	24 to 230 VAC (50/60 Hz)/24 to 48 VDC
Operating voltage range	85% to 110% of rated supply voltage
Power reset	Minimum power-off time: 0.1 s
Reset voltage	2.4 VAC/DC max.
Power consumption	AC: 33 VA max./2.2 W max. (typical: 31 VA/2.0 W) at 230 VAC 11 VA max./1.9 W max. (typical: 9.7 VA/1.7 W) at 100 to 120 VAC DC: 0.7 W max. (typical: 0.6 W) at 24 VDC 1.4 W max. (typical: 1.2 W) at 48 VDC
Voltage input	Max. permissible capacitance between inputs lines (terminals B1 and A2): 2,000 pF Load connectable in parallel with inputs (terminals B1 and A1). H-level: 20.4 to 253 VAC/20.4 to 52.8 VDC L-level: 0 to 2.4 VAC/DC
Control output	Contact output: 5 A at 250 VAC with resistive load ($\cos\phi = 1$) 5 A at 30 VDC with resistive load ($\cos\phi = 1$)
Ambient temperature	Operating: -10°C to 55°C (with no icing) Storage: -25°C to 65°C (with no icing)
Ambient humidity	Operating: 35% to 85%

Note: DC ripple rate: 20% max.

■ Characteristics

Accuracy of operating time	±1% max. of FS (±1% ±10 ms max. at 1.2-s range)
Setting error	±10% ± 50 ms max. of FS
Influence of voltage	±0.5% max. of FS (±0.5% ±10 ms max. at 1.2-s range)
Influence of temperature	±5% max. of FS (±5% ± 10 ms max. at 1.2-s range)
Insulation resistance	100 MΩ min. at 500 VDC
Dielectric strength	Between current-carrying metal parts and exposed non-current-carrying metal parts: 2,000 VAC (50/60 Hz) for 1 min. Between control output terminals and operating circuit: 2,000 VAC (50/60 Hz) for 1 min. Between contacts not located next to each other: 1,000 VAC (50/60 Hz) for 1 min.
Impulse withstand voltage	3 kV (between power supply terminals) 4.5 kV (between current-carrying metal parts and exposed non-current-carrying metal parts)
Noise immunity	Square-wave noise generated by noise simulator (pulse width: 100 ns/1 μs, 1-ns rise) ±1.5 kV
Static immunity	Malfunction: 4 kV Destruction: 8 kV
Vibration resistance	Malfunction: 0.5-mm single amplitude at 10 to 55 Hz Destruction: 0.75-mm single amplitude at 10 to 55 Hz
Shock resistance	Malfunction: 200 m/s ² , 3 times each in 6 directions Destruction: 300 m/s ² , 3 times each in 6 directions
Life expectancy	Mechanical: 10 million operations min. (under no load at 1,800 operations/h) Electrical: 100,000 operations min. (5 A at 250 VAC, resistive load at 360 operations/h) (see note)
EMC	(EMI) EN61812-1 Emission Enclosure: EN55011 Group 1 class B Emission AC Mains: EN55011 Group 1 class B Harmonic Current: EN61000-3-2 Voltage Fluctuation and Flickering: EN61000-3-3 (EMS) EN61812-1 Immunity ESD: EN61000-4-2: 6 kV contact discharge (level 3) 8 kV air discharge (level 3) Immunity RF-interference from AM Radio Waves: EN61000-4-3: 10 V/m (80 MHz to 1 GHz) (level 3) Immunity Burst: EN61000-4-4: 2 kV power port and output port (level 3) 1 kV control port with capacitive clamp (level 3) Immunity Surge: EN61000-4-5: 2 kV common mode (level 3) 1 kV differential mode (level 3)
Case color	Light gray (5Y7/1)
Degree of protection	IP30 (IP20 for terminal block)
Weight	Approx. 70 g

Note: For reference:

A maximum current of 0.15 A can be switched at 125 VDC (cosφ=1).

A maximum current of 0.1 A can be switched if L/R is 7 ms.

In both cases, a life of 100,000 operations can be expected.

The minimum applicable load is 10 mA at 5 VDC (failure level: P).

Nomenclature

H3DS-FL□

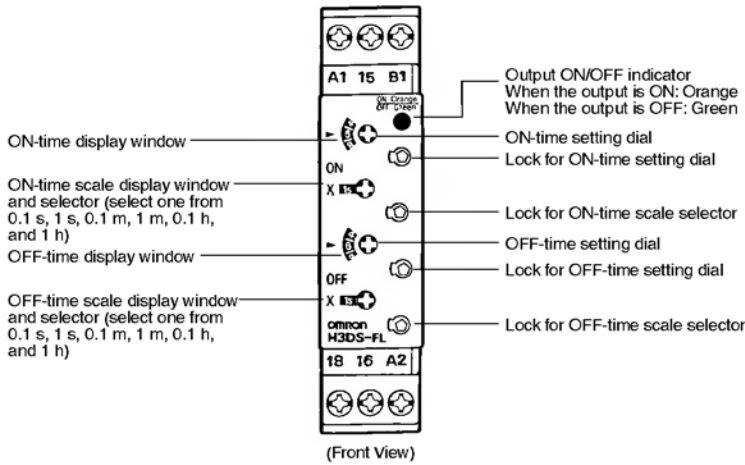

H3DS-FLC

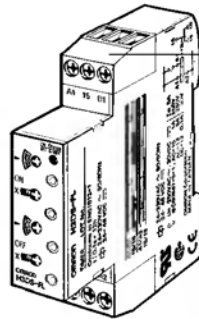
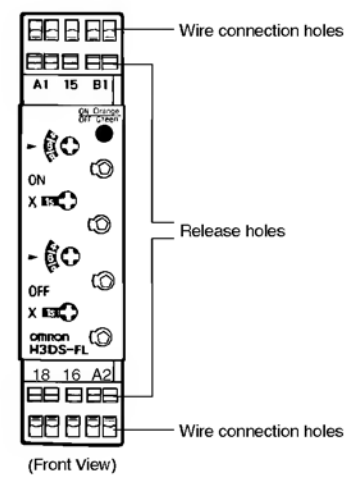

Attach the enclosed label here as a nameplate.
(The label is attached to the Timer's DIN Track hook section at the time of shipment.)

Operation

■ Block Diagram

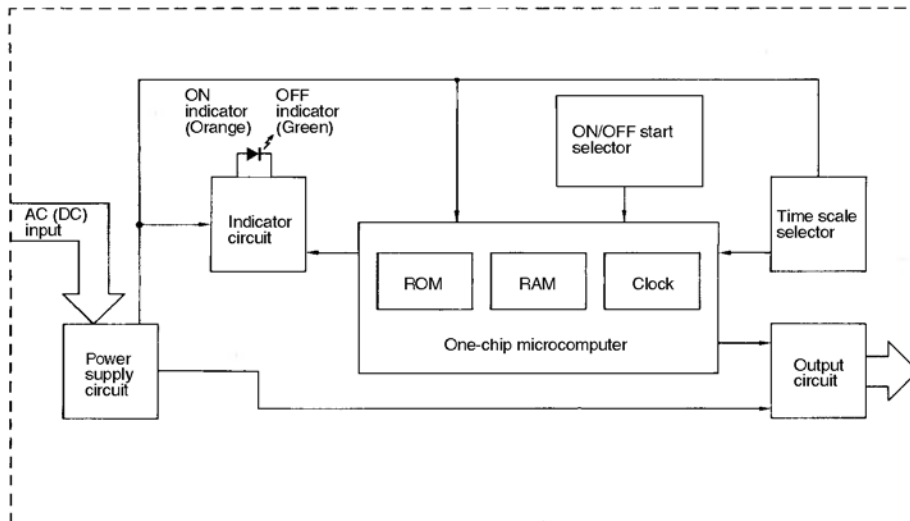

■ I/O Function

Inputs	Flicker-ON start operation begins when inputs are turned ON.	
Outputs	Control output	Outputs are turned ON/OFF according to the time set by the ON- and OFF-time setting dial.

■ Basic Operation

Setting of Selector

The selectors can be turned clockwise and counterclockwise to select the desired time scale, or operating mode.

Each selector has a snap mechanism that secures the selector at a given position. Set the selector at a position at which it is secured. Do not set it midway between two securing positions or a malfunction could result from improper setting.

Settings for ON/OFF Start

If voltage is applied to terminal B1, or if terminals A1 and B1 are shorted, the operating mode is switched to flicker-ON start mode. If these terminals are disconnected, the mode switches to flicker-OFF start mode. The operating mode will not change if the state of the applied voltage changes during timer operation.

Selection of Time Scale

The time scale is selected by turning the ON-time scale selector and OFF-time scale selector. The time scales will appear in the following order in each time scale display window on the left of the selector:

0.1 s, 1 h, 0.1 h, 1 m, 1 s, 0.1 h, 0.1 m, 1 s.

Note: The time scales "1 s" and "0.1 h" appear twice. Both instances indicate exactly the same time scale.

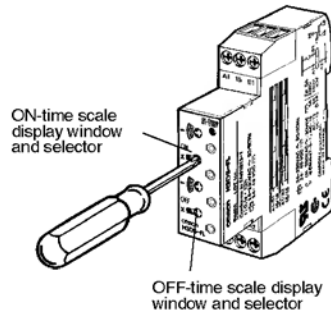

Time Setting

Use the ON/OFF-time setting dials to set the ON/OFF time.

Locking/Unlocking of Selectors and Time Setting Dial

The ON/OFF-time setting dials and time scale selectors can be locked using the Y92S-38 Lock Key, a special pen type tool that is sold separately. To lock the dials or selectors, insert the Lock Key in the keyhole to the lower right of the dial or selector and turn it clockwise until the dial or selector is completely covered with the red cover. To unlock, turn the Lock Key in the opposite direction.

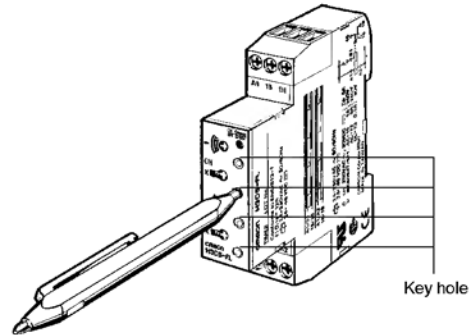

■ Timing Charts

Operating mode	Timing chart	
Flicker-OFF start (See note 1.)	Power (A ₁ and A ₂) ON OFF Output relay: NO 15 and 18 (ON indicator) ON OFF Output relay: NC 15 and 16 ON OFF OFF indicator ON OFF	<p>t_{ON}: ON set time t_{OFF}: OFF set time</p>
Flicker-ON start (See note 1.)	Power (A ₁ and A ₂) ON OFF Signal (B ₁ and A ₂) ON OFF Output relay: NO 15 and 18 (ON indicator) ON OFF Output relay: NC 15 and 16 ON OFF OFF indicator ON OFF	<p>t_{ON}: ON set time t_{OFF}: OFF set time</p>

- Note:**
1. If voltage is applied to terminal B1, or if terminals A1 and B1 are shorted, the operating mode is switched to flicker-ON start mode. If these terminals are disconnected, the mode switches to flicker-OFF start mode.
 2. The reset time requires a minimum of 0.1 s.
 3. When power is supplied in flicker-ON start mode, the OFF indicator lights momentarily. This, however, has no effect on the performance of the Timer.

Dimensions

H3DS-FL

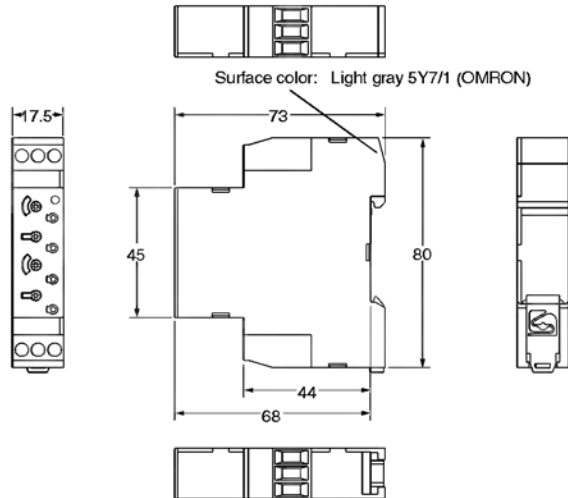
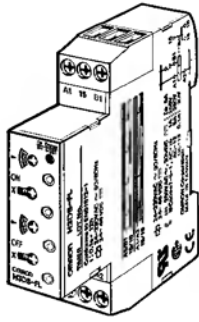

H3DS-FLC

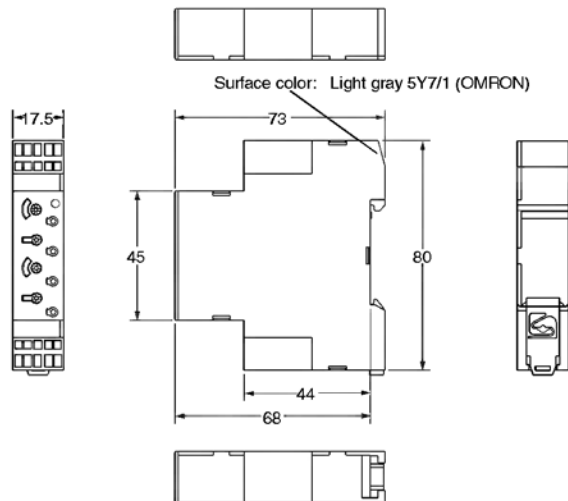
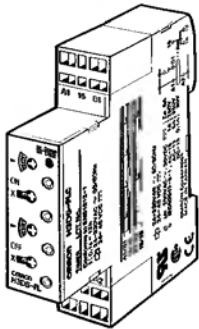

Installation

■ Terminal Arrangement

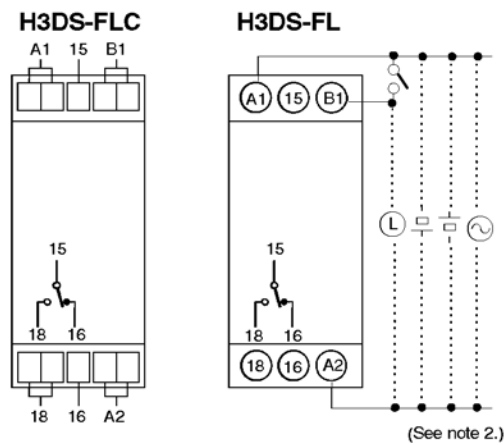

- Note:**
1. If voltage is applied to terminal B1, or if terminals A1 and B1 are shorted, the operating mode is switched to flicker-ON start mode. If these terminals are disconnected, the mode switches to flicker-OFF start mode.
 2. DC supply voltage does not require the designation of polarity.

Solid-state Star-delta Timer

H3DS-G

- A wide star-time range (up to 120 seconds) and star-delta transfer time range (up to 1 second)



Ordering Information

Operating mode	Supply voltage	Model	
		Screw terminal type	Screw-Less Clamp type
Star-delta operation	24 to 230 VAC (50/60 Hz)/24 to 48 VDC	H3DS-GL	H3DS-GLC

■ Model Number Legend

H3DS -G L
 1 2 3

1. G: Star-delta timer
2. L: Smart lock mechanism
3. None: Screw terminal type
 C: Screw-Less Clamp type

■ Accessories (Order Separately)

Lock Key		Y92S-38
Mounting Track	50 cm (l) x 7.3 mm (t)	PFP-50N
	1 m (l) x 7.3 mm (t)	PFP-100N
	1 m (l) x 16 mm (t)	PFP-100N2
End Plate		PFP-M
Spacer		PEP-S

Specifications

■ General

Item	H3DS-G
Operating mode	Star-delta operation
Operating/Reset method	Time-limit operation/Self-reset
External connections	Screw terminal, Screw-Less Clamp
Terminal block	Screw terminal type: Clamps two 2.5-mm ² max. bar terminals without sleeves. Screw-Less Clamp type: Clamps two 1.5-mm ² max. bar terminals without sleeves.
Terminal screw tightening torque	0.98 N • m max.
Output type	(Star operation circuit) Relay: SPST-NO (Delta operation circuit) Relay: SPST-NO
Mounting method	DIN track mounting (see note)
Attachment	Nameplate label
Approved standards	UL508, CSA C22.2 No.14 Conforms to EN61812-1, IEC60664-1 (VDE0110) 4 kV/2, VDE0106/P100 Output category according to IEC60947-5-1 (AC-13; 250 V 5A/AC-15; 250 V 1 A/DC-13; 30 V 0.1 A)

Note: Can be mounted to 35-mm DIN Track with a plate thickness of 1 to 2.5 mm.

■ Time Ranges

Time scale	Star operation time ranges
x 1	1 to 12 s
x 10	10 to 120 s

Star-delta transfer time	Programmable at 0.05 s, 0.1 s, 0.5 s, or 1 s
--------------------------	--

■ Ratings

Rated supply voltage (see note)	24 to 230 VAC (50/60 Hz)/24 to 48 VDC
Operating voltage range	85% to 110% of rated supply voltage
Power reset	Minimum power-off time: 0.5 s
Reset voltage	2.4 VAC/DC max.
Power consumption	AC: 21 VA max./1.7 W max. (typical: 20 VA/1.6 W) at 230 VAC 11 VA max./2.0 W max. (typical: 8.6 VA/1.5 W) at 100 to 120 VAC DC: 1.3 W max. (typical: 1.2 W) at 24 VDC 0.7 W max. (typical: 0.6 W) at 48 VDC
Control output	Contact output: 5 A at 250 VAC with resistive load ($\cos\phi = 1$) 5 A at 30 VDC with resistive load ($\cos\phi = 1$)
Ambient temperature	Operating: -10°C to 55°C (with no icing) Storage: -25°C to 65°C (with no icing)
Ambient humidity	Operating: 35% to 85%

Note: DC ripple rate: 20% max.

■ Characteristics

Accuracy of operating time	±1% max. of FS
Setting error	±10% ± 50 ms max. of FS
Total tolerance of transfer time	± (25% FS + 5 ms) max.
Influence of voltage	±0.5% max. of FS
Influence of temperature	±5% max. of FS
Insulation resistance	100 MΩ min. at 500 VDC
Dielectric strength	Between current-carrying metal parts and exposed non-current-carrying metal parts: 2,000 VAC (50/60 Hz) for 1 min. Between control output terminals and operating circuit: 2,000 VAC (50/60 Hz) for 1 min. Between contacts not located next to each other: 1,000 VAC (50/60 Hz) for 1 min.
Impulse withstand voltage	3 kV (between power supply terminals) 4.5 kV (between current-carrying metal parts and exposed non-current-carrying metal parts)
Noise immunity	Square-wave noise generated by noise simulator (pulse width: 100 ns/1 μs, 1-ns rise) ±1.5 kV
Static immunity	Malfunction: 4 kV Destruction: 8 kV
Vibration resistance	Malfunction: 0.5-mm single amplitude at 10 to 55 Hz Destruction: 0.75-mm single amplitude at 10 to 55 Hz
Shock resistance	Malfunction: 200 m/s ² , 3 times each in 6 directions Destruction: 300 m/s ² , 3 times each in 6 directions
Life expectancy	Mechanical: 10 million operations min. (under no load at 1,800 operations/h) Electrical: 100,000 operations min. (5 A at 250 VAC, resistive load at 360 operations/h) (see note)
EMC	(EMI) EN61812-1 Emission Enclosure: EN55011 Group 1 class B Emission AC Mains: EN55011 Group 1 class B Harmonic Current: EN61000-3-2 Voltage Fluctuation and Flickering: EN61000-3-3 (EMS) EN61812-1 Immunity ESD: EN61000-4-2: 6 kV contact discharge (level 3) 8 kV air discharge (level 3) Immunity RF-interference from AM Radio Waves: EN61000-4-3: 10 V/m (80 MHz to 1 GHz) (level 3) Immunity Burst: EN61000-4-4: 2 kV power port and output port (level 3) 1 kV control port with capacitive clamp (level 3) Immunity Surge: EN61000-4-5: 2 kV common mode (level 3) 1 kV differential mode (level 3)
Case color	Light gray (5Y7/1)
Degree of protection	IP30 (IP20 for terminal block)
Weight	Approx. 70 g

Note: For reference:

A maximum current of 0.15 A can be switched at 125 VDC ($\cos\phi=1$).

A maximum current of 0.1 A can be switched if L/R is 7 ms.

In both cases, a life of 100,000 operations can be expected.

The minimum applicable load is 10 mA at 5 VDC (failure level: P).

Nomenclature

H3DS-GL□

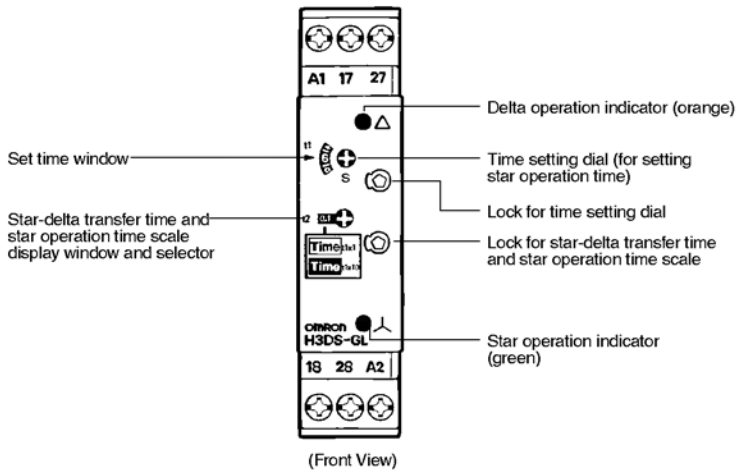

H3DS-GLC

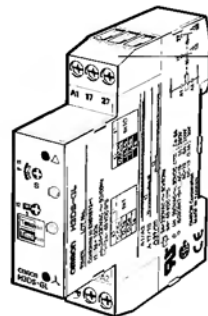
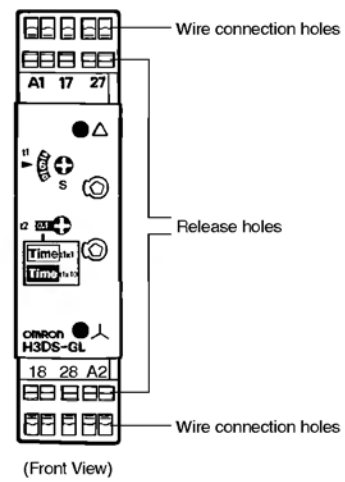

Attach the enclosed label here as a nameplate. (The label is attached to the Timer's DIN Track hook section at the time of shipment.)

Operation

■ Block Diagram

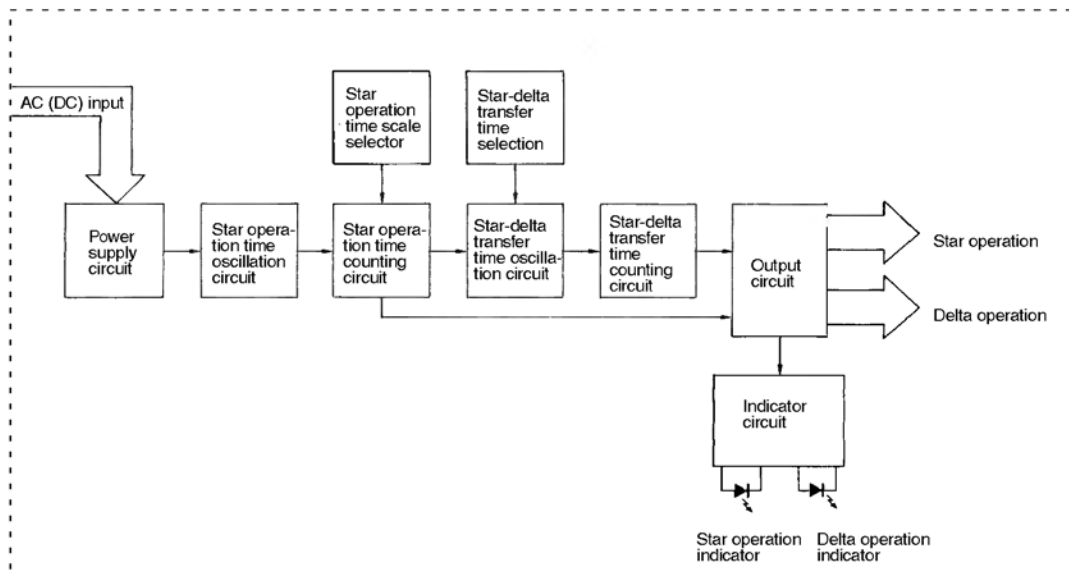

■ I/O Functions

Inputs		—
Outputs	Control output	Star output is turned OFF when the dial set value is reached and delta output is ON after the preset transfer time elapses

■ Basic Operation

Setting of Selector

The selectors can be turned clockwise and counterclockwise to select the desired time scale, or operating mode.

Each selector has a snap mechanism that secures the selector at a given position. Set the selector at a position at which it is secured. Do not set it midway between two securing positions or a malfunction could result from improper setting.

Selection of Time Unit and Time Scale

The star-delta transfer time and star operation time scale are set with the same selector. The star-delta transfer time can be set to 0.05, 0.1, 0.5, or 1. The star operation time scale can be set to a multiplication factor of 1 or 10. If the star-delta transfer time is displayed in the display window in white letters, this means that the star operation time scale is "x10". Refer to the example below.

Star-delta transfer time	Star operation time scale
0.05 s	x1
0.1 s	
0.5 s	
1 s	
0.05 s	x10
0.1 s	
0.5 s	
1 s	

Time Setting

The star operation time of the Timer is set with the time setting dial.

Locking/Unlocking of Selectors and Time Setting Dial

The time setting dial and time scale selector can be locked using the Y92S-38 Lock Key, a special pen type tool that is sold separately. To lock the dial or selectors, insert the Lock Key in the key-hole to the lower right of the dial or selector and turn it clockwise until the dial or selector is completely covered with the red cover. To unlock, turn the Lock Key in the opposite direction.

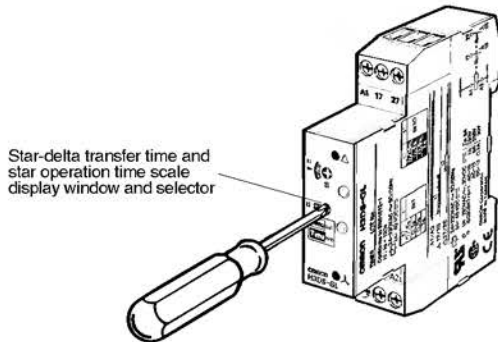
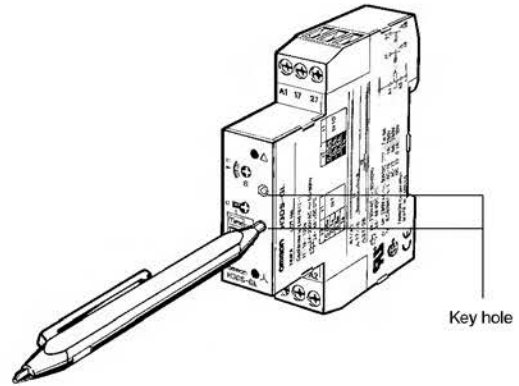

■ Timing Charts

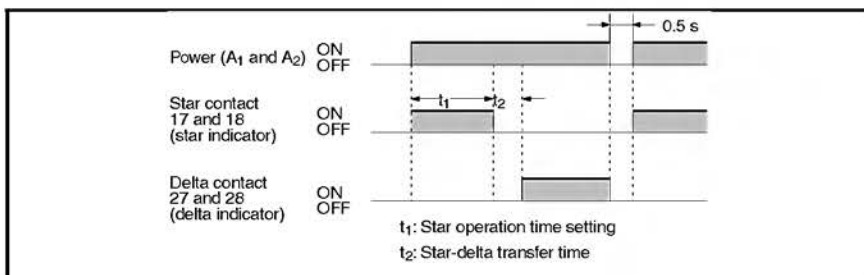

Note: The reset time requires a maximum of 0.5 s.

Dimensions

H3DS-GL

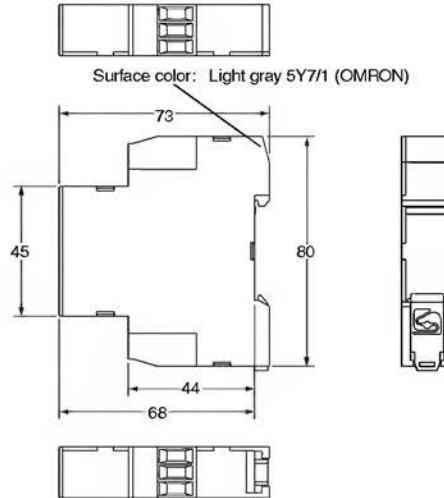
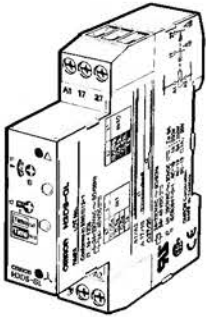

H3DS-GLC

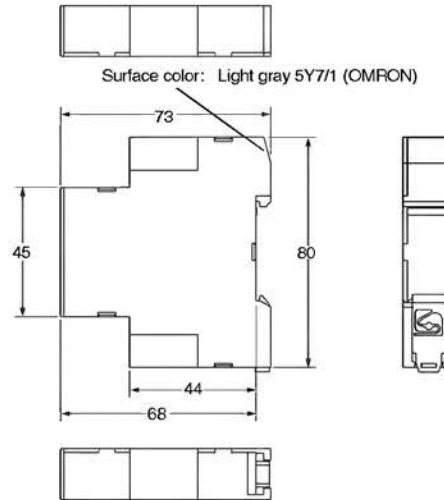
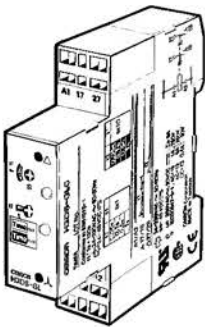

Installation

■ Terminal Arrangement

H3DS-GLC

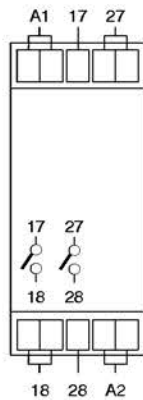

H3DS-GL

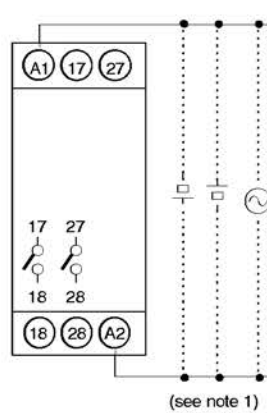

Note: DC supply voltage does not require the designation of polarity.

- Covers wide range of supply voltage (24 to 230 VAC/VDC).



Ordering Information

Supply voltage	Input type	Operating mode	Model	
			Screw terminal type	Screw-Less Clamp type
24 to 230 VAC/VDC (50/60 Hz)	No-input available	ON-delay	H3DS-XL	H3DS-XLC

Model Number Legend

H3DS -X L □
1 2 3

- X: Two-wired timer
- L: Smart lock mechanism
- None: Screw terminal type
C: Screw-Less Clamp type

Accessories (Order Separately)

Lock Key		Y92S-38
Mounting Track	50 cm (l) x 7.3 mm (t)	PFP-50N
	1 m (l) x 7.3 mm (t)	PFP-100N
	1 m (l) x 16 mm (t)	PFP-100N2
End Plate		PFP-M
Spacer		PEP-S

Specifications

■ General

Item	H3DS-X
Operating mode	ON-delay
Operating/Reset method	Time-limit operation/self-resetting
Output type	SCR output
External connections	Screw terminal, Screw-Less Clamp
Terminal block	Screw terminal type: Clamps two 2.5-mm ² max. bar terminals without sleeves. Screw-Less Clamp type: Clamps two 1.5-mm ² max. bar terminals without sleeves.
Terminal screw tightening torque	0.98 N • m max.
Mounting method	DIN track mounting (see note)
Attachment	Nameplate label
Approved standards	UL508, CSA C22.2 No.14 Conforms to EN61812-1, IEC60664-1 (VDE0110) 4 kV/2, VDE0106/P100

Note: Can be mounted to 35-mm DIN Track with a plate thickness of 1 to 2.5 mm.

■ Time Ranges

Time scale display	Time range
0.1 s	0.1 to 1.2 s
1 s	1 to 12 s
0.1 m	0.1 to 1.2 min
1 m	1 to 12 min
0.1 h	0.1 to 1.2 h
1 h	1 to 12 h
10 h	10 to 120 h

Note: When the time setting dial is set to "0" for any time scale, the output will operate instantaneously.

■ Ratings

Rated supply voltage (see note)	24 to 230 VAC/VDC (50/60 Hz)
Operating voltage range	85% to 110% of rated supply voltage
Power reset	Minimum power-off time: 0.1 s
Reset voltage	1.0 VAC/VDC max.
Reset current	5 mA max.
Power consumption	5 mA max.
Control output	SCR output: 5 mA to 0.7 A
Ambient temperature	Operating: -10°C to 55°C (with no icing) Storage: -25°C to 65°C (with no icing)
Ambient humidity	Operating: 35% to 85%

Note: The ripple in DC power supply must be 5% max.

■ Characteristics

Accuracy of operating time	±1% max. of FS (±1% ±10 ms max. at 1.2-s range)
Setting error	±10% ± 50 ms max. of FS
Reset time	0.1 s max.
Influence of voltage	±0.5% max. of FS (±0.5%±10 ms max. at 1.2-s range)
Influence of temperature	±5% max. of FS (±5%±10 ms max. at 1.2-s range)
Insulation resistance	100 MΩ min. at 500 VDC
Dielectric strength	Between current-carrying metal parts and exposed non-current-carrying metal parts: 2,000 VAC for 1 min
Impulse withstand voltage	3 kV (between power supply terminals) 4.5 kV (between current-carrying metal parts and exposed non-current-carrying metal parts)
Noise immunity	Square-wave noise generated by noise simulator (pulse width: 100 ns/1 μs, 1-ns rise) ±1.5 kV (between power supply terminals)
Static immunity	Malfunction: 4 kV Destruction: 8 kV
Vibration resistance	Malfunction: 0.5-mm single amplitude at 10 to 55 Hz Destruction: 0.75-mm single amplitude at 10 to 55 Hz
Shock resistance	Malfunction: 200 m/s ² , 3 times each in 6 directions Destruction: 300 m/s ² , 3 times each in 6 directions
EMC	(EMI) EN61812-1 Emission Enclosure: EN55011 Group 1 class B Emission AC Mains: EN55011 Group 1 class B Harmonic Current: EN61000-3-2 Voltage Fluctuation and Flickering: EN61000-3-3 (EMS) EN61812-1 Immunity ESD: EN61000-4-2: 6 kV contact discharge (level 3) 8 kV air discharge (level 3) Immunity RF-interference from AM Radio Waves: EN61000-4-3: 10 V/m (80 MHz to 1 GHz) (level 3) Immunity Burst: EN61000-4-4: 2 kV power port and output port (level 3) 1 kV control port with capacitive clamp (level 3) Immunity Surge: EN61000-4-5: 2 kV common mode (level 3) 1 kV differential mode (level 3)
Case color	Light gray (5Y7/1)
Degree of protection	IP30 (IP20 for terminal block)
Weight	Approx. 70 g

Nomenclature

H3DS-XL□

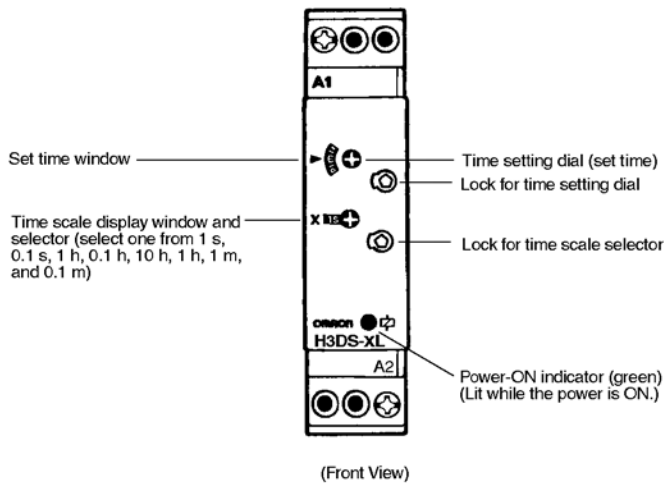

H3DS-XLC

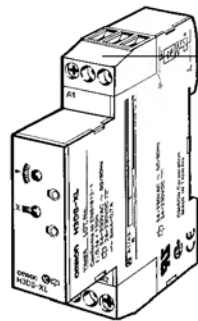
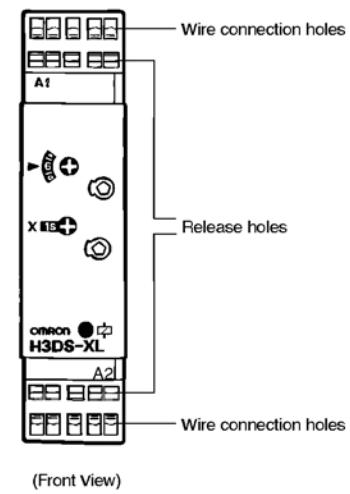

Attach the enclosed label here as a nameplate. (The label is attached to the Timer's DIN Track hook section at the time of shipment.)

Operation

■ Block Diagram

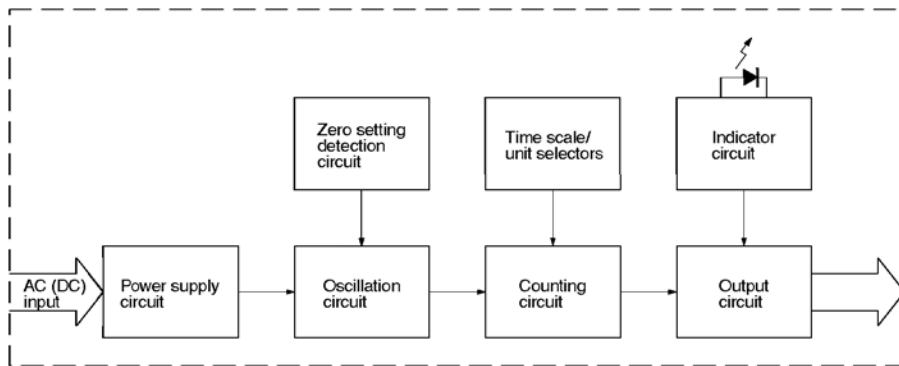

■ I/O Functions

Inputs	---	
Outputs	Control output	Outputs are turned ON when the preset value is reached.

■ Basic Operation

Setting of Selector

The selectors can be turned clockwise and counterclockwise to select the desired time scale, or operating mode.

Each selector has a snap mechanism that secures the selector at a given position. Set the selector at a position at which it is secured. Do not set it midway between two securing positions or a malfunction could result from improper setting.

Selection of Time Scale

The time scale is selected by turning the time scale selector. The time scales will appear in the following order in the time scale display window on the left of the selector:

1 s, 0.1 s, 1 h, 0.1 h, 10 h, 1 h, 1 m, 0.1 m.

Note: The time scale “1h” appears twice. Both instances indicate exactly the same time scale.

Locking/Unlocking of Selectors and Time Setting Dial

The time setting dial and time scale selector can be locked using the Y92S-38 Lock Key, a special pen type tool that is sold separately. To lock the dial or selectors, insert the Lock Key in the key hole to the lower right of the dial or selector and turn it clockwise until the dial or selector is completely covered with the red cover. To unlock, turn the Lock Key in the opposite direction.

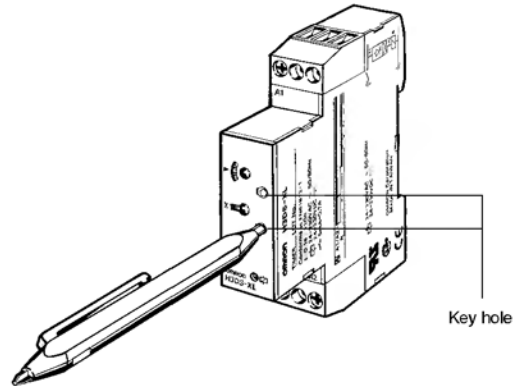
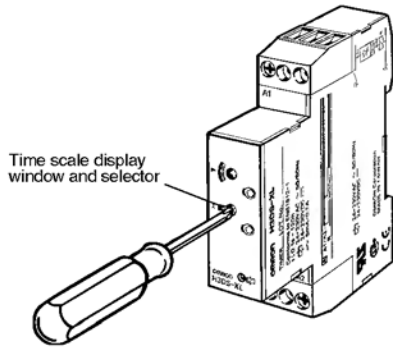

■ Timing Charts

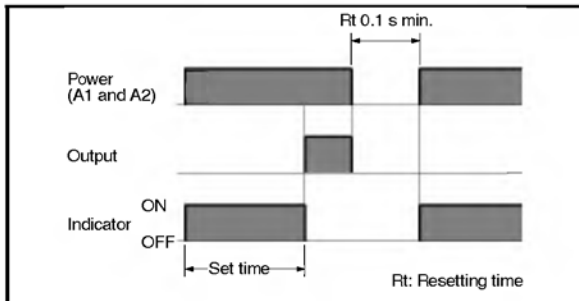

Dimensions

H3DS-XL

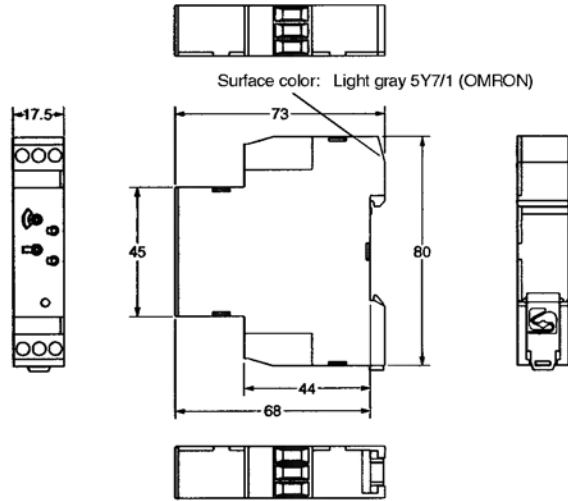
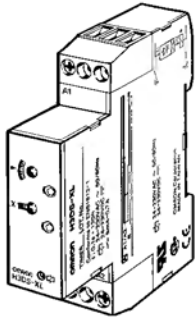

H3DS-XLC

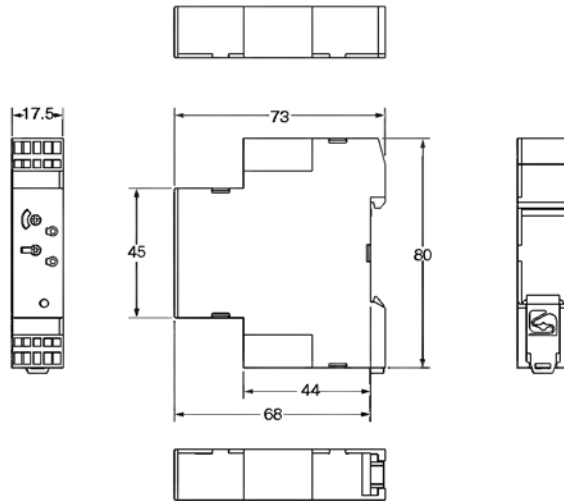
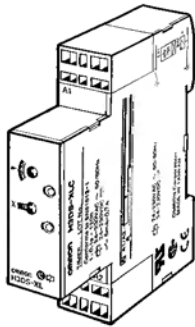

Installation

Terminal Arrangement

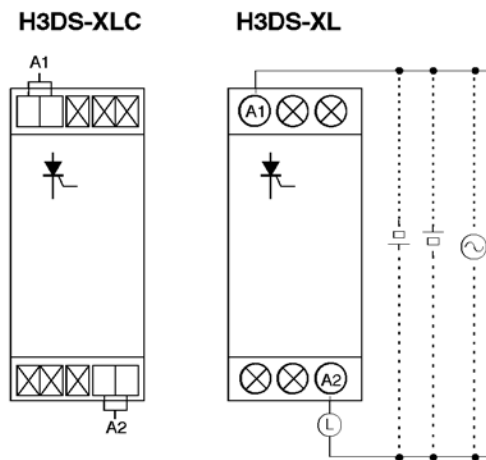

Note: DC supply voltage does not require the designation of polarity.

Installation of Screw-Less Clamp Models

■ Tools

A flat-blade screwdriver should be used to mount the cables.

Applicable Screwdriver

- Flat-blade, Parallel-tip, 2.5 mm diameter

- Flat-blade, Parallel-tip



- Flat-blade, Flared-tip

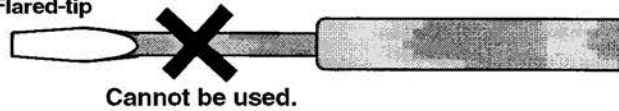

Examples: FACOM AEF.2.5 × 75E
VESSEL No. 9900(-)2.5 × 75
WAGO 210-119
WIHA 260/2.5 × 40

■ Applicable Wires

Applicable Wire Sizes

0.2 to 1.5 mm², AWG24 to AWG16

Applicable Wire Type

Solid wires, stranded wires, flexible wires, or wires with ferules can be used.

(See note 1) $1.8 \leq \text{Diameter } D \text{ (mm)} \leq 3.0$ (see note 2)

Conductor diameter d (mm) or length of sides a and b (mm) ≤ 1.6

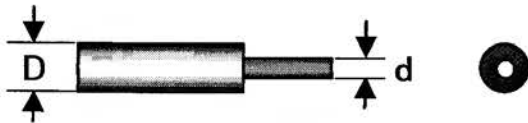

Wires with Ferules



Note: 1. If the overall diameter of the wire is less than 1.8 mm, do not insert the wire past the conductor. Refer to the following diagrams.



2. If the overall diameter of the wire is over 2.8 mm, it will be difficult to use double wiring.

■ Wiring

Use wires of the applicable sizes specified above. The length of the exposed conductor should be 6 to 7 mm.

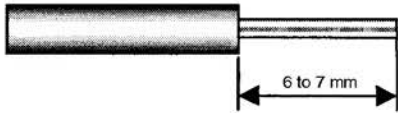

Fig. 1 Exposed Conductor Length

Use the following wiring procedure.

1. Insert the specified screwdriver into the release hole located beside the wire connection hole where the wire is to be inserted.

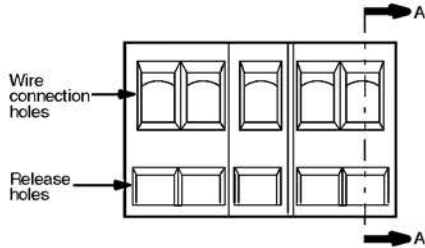

Fig. 2 Wire Connection Holes and Release Holes

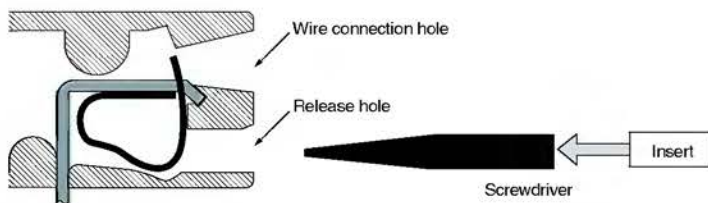
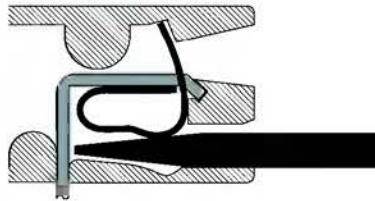
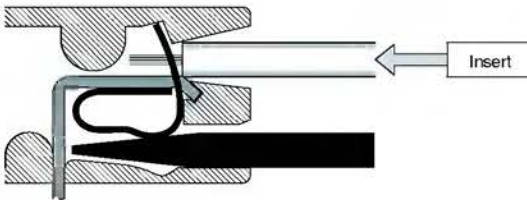

Fig. 3 Section A-A of Fig. 2



2. Insert the exposed conductor into the wire connection hole.



3. Pull out the screwdriver.

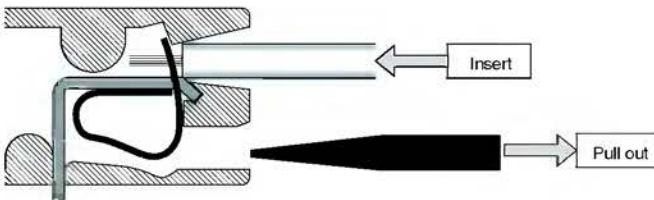

■ Precautions

Always insert the screwdriver straight into the hole, never at an angle. The clamp spring may be deformed if the screwdriver is not straight.

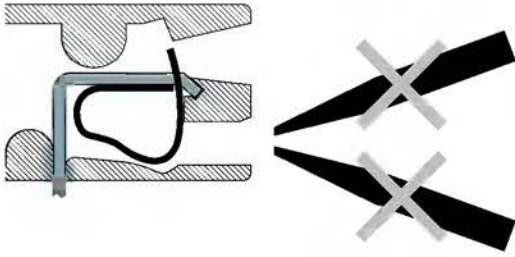

Do not move the screwdriver side to side in the clamp hole. The clamp spring may be deformed if the screwdriver is moved sideways.

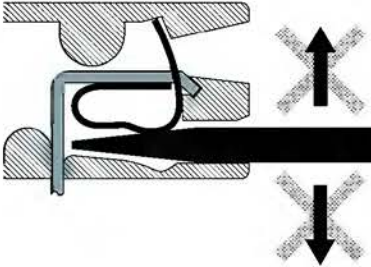

Accessories (Order Separately)

Note: All units are in millimeters unless otherwise indicated.

■ Dimensions

Lock Key Y92S-38

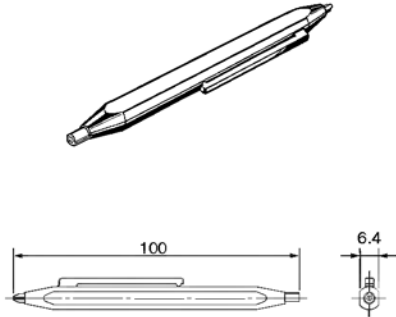

Mounting Track PFP-100N, PFP-50N

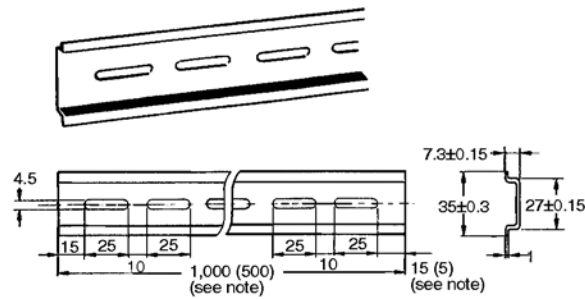

PFP-100N2

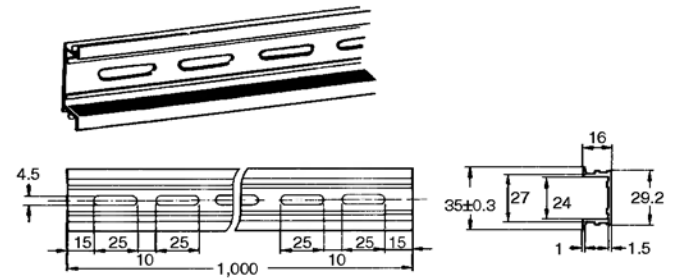

Note: The values shown in parentheses are for the PFP-50N.

End Plate PFP-M

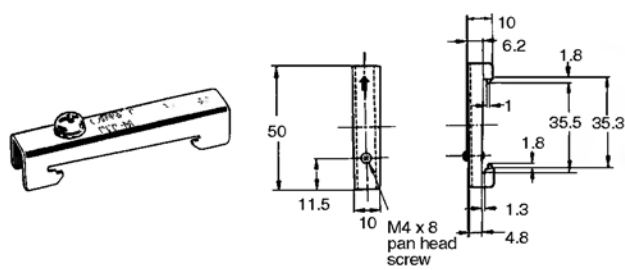

Spacer PFP-S

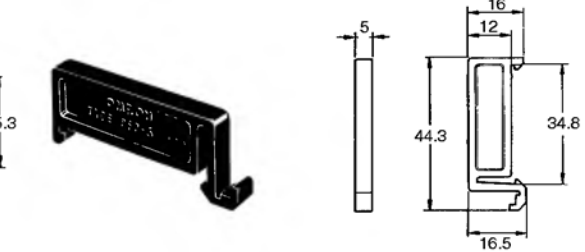

Precautions

■ Changing of Setting

⚠ NOTICE: Do not change the time scale or operating mode, while the Timer is in operation or malfunction could result.

■ Power Supplies

The H3DS Series is provided with a transformerless power supply system. An electric shock may be received if the input terminal is touched while power is being supplied.

Use the bar terminal for wiring the H3DS. Using a stranded-wire terminal may cause a short-circuit due to a stray wire entering into the Timer.

Both AC and DC power supplies can be connected to the power input terminals without regarding polarity.

With the H3DS only, a DC power supply must be connected to the power input terminals as designated according to the polarity of the terminals.

A DC power supply can be connected if its ripple factor is 20% or less and the mean voltage is within the rated operating voltage range of the Timer.

Make sure that the voltage is applied within the specified range, otherwise the internal elements of the Timer may be damaged.

Connect the power supply voltage through a relay or switch in such a way that the voltage reaches a fixed value at once or the Timer may not be reset or a timer error could result.

For the power supply of an input device of the H3DS-ML□, use an isolating transformer, of which the primary and secondary windings are mutually isolated and the secondary winding is not grounded.

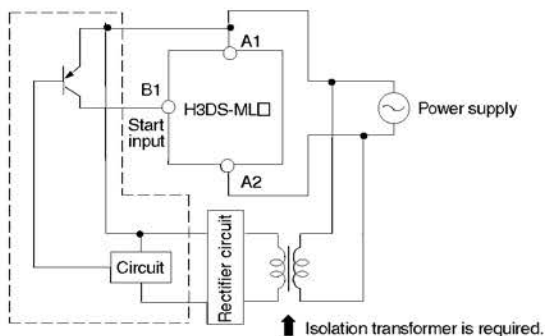

■ Installation

If the load current is continuously being supplied to the Timer for a long period of time, be sure to provide the mounting clearance as shown in the figure below. If used under the conditions other than those specified below (except for the H3DS-XL□), the life of internal components may be shortened due to an excessive rise in the internal temperature.

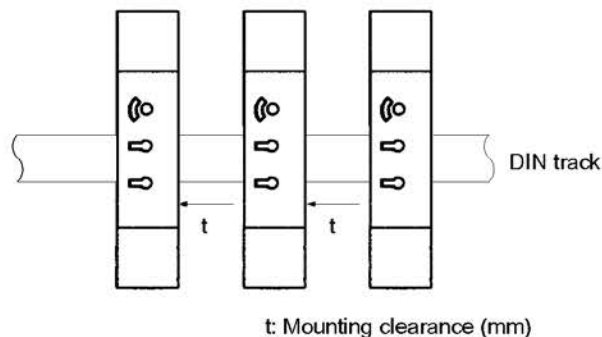

Switching Current vs. Ambient Temperature (When Mounting Two or More H3DS Units Side-by-Side)

• H3DS-ML□/-SL□/-AL□

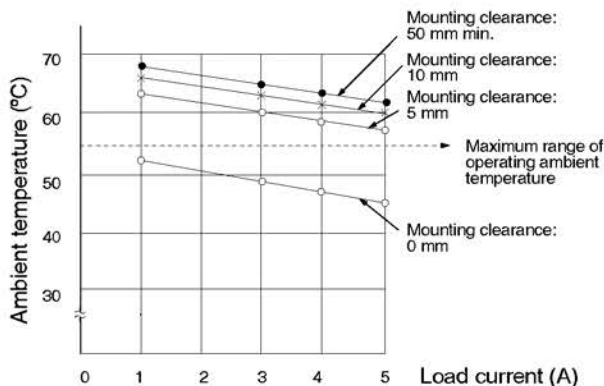

(Measurement Condition: Input voltage of 230 VAC)

• H3DS-FL□/-GL□

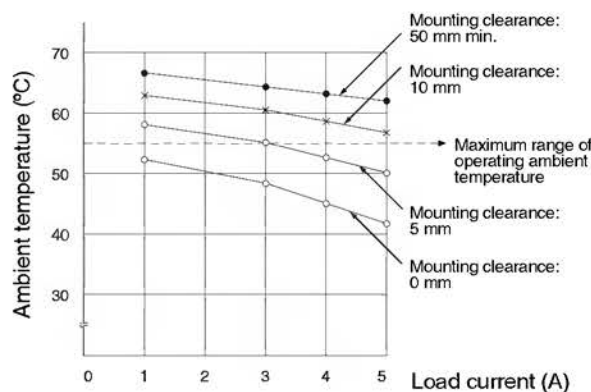

(Measurement Condition: Input voltage of 230 VAC)

■ Input/Output

Relationship between Input and Power Supply Circuits (H3DS-ML□)

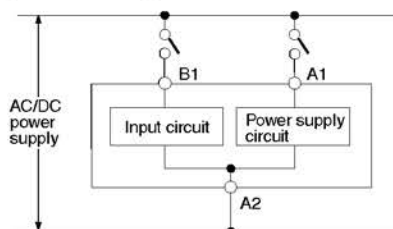

Since the input circuit and the power supply circuit are configured independently, the input circuit can be turned on or off irrespective of the on/off state of the power supply. It must be noted that a voltage equivalent to the power supply voltage is applied to the input circuit.

When connecting a relay or a transistor as an external signal input device, pay attention to the following points to prevent short-circuiting due to a sneak current to the transformerless power supply.

If a relay or transistor is connected to two or more Timers, the input terminals of those Timers must be wired properly so that they will not be different in phase or the terminals will be short-circuited to one another (refer to the figures below).

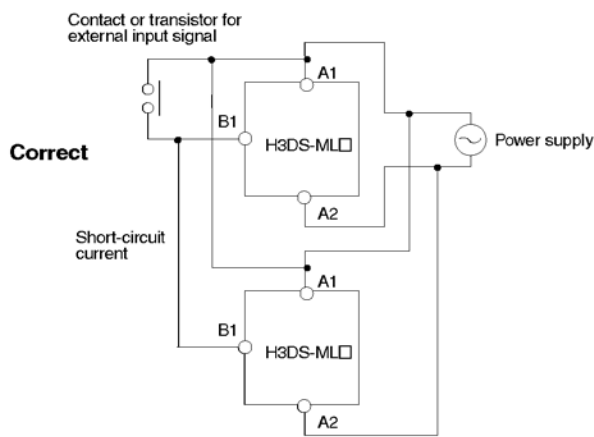
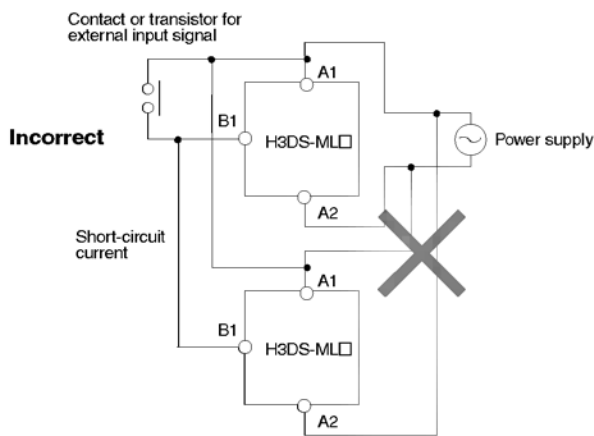

The H3DS Series is provided with a transformerless power supply system.

Input Wires

The input wires must be as short as possible. If the floating capacity of wires exceeds 2,000 pF (approx. 17 m for cables with 120 pF/m), the operation will be affected. Pay particular attention when using shielded cables.

■ Precautions for EN61812-1 Conformance

The H3DS as a built-in timer conforms to EN61812-1 provided that the following conditions are satisfied:

The output section of the H3DS is provided only with basic isolation. To ensure reinforced isolation required by the EN61812-1, provide supplementary basic isolation on the load side connected to the output.

The H3DS itself is designed according to the following:

- Overvoltage category III
- Pollution degree 2

On the above basis:

Operation parts on the front and bottom: Reinforced isolation

- With clearance of 5.5 mm and creepage distance of 5.5 mm at 230 VAC

Output: Basic isolation

- With clearance of 3 mm and creepage distance of 3 mm at 230 VAC

■ Environment

When using the Timer in an area with excess electronic noise, separate the Timer, wiring, and the equipment which generates the input signals as far as possible from the noise sources. It is also recommended to shield the input signal wiring to prevent electronic interference.

Organic solvents (such as paint thinner), as well as very acidic or basic solutions can damage the outer casing of the Timer.

Do not use the Timer in places where it is exposed to dust, corrosive gas, or direct sunlight.

When storing the Timer, make sure that the ambient temperature and humidity are within the rated values. Leave the Timer at room temperature for at least three hours before using the Timer if it has been stored at an ambient temperature of -10°C or below.

■ Others

If the Timer is mounted on a control board, dismount the Timer from the control board or short-circuit the circuitry of the power board before carrying out a voltage withstand test between the electric circuitry and non current-carrying metal part of the Timer, in order to prevent the internal circuitry of the Timer from damage.

ALL DIMENSIONS SHOWN ARE IN MILLIMETERS.

To convert millimeters into inches, multiply by 0.03937. To convert grams into ounces, multiply by 0.03527.

Cat. No. L098-E1-3 **In the interest of product improvement, specifications are subject to change without notice.**

OMRON Corporation

Industrial Automation Company

Measuring and Supervisory Controls Department
Shiokoji Horikawa, Shimogyo-ku
Kyoto, 600-8530 Japan
Tel: (81)75-344-7108/Fax: (81)75-344-7189

Printed in Japan
0801-2M (0200) (O)

- Highly visible display with backlit negative transmissive LCD.
- Programmable PV color to visually alert when output status changes (screw terminal block models).
- Intuitive setting enabled using DIP switch (H5CX-A/-A11 models) and ergonomic up/down digit keys.
- Twin timer in one body to meet a broader range of cyclic control application requirements as well as ON/OFF duty adjustable flicker mode.
- PNP/NPN switchable input (H5CX-A/-A11 models)
- Finger-safe terminals (screw terminal block models)
- Meet a variety of mounting requirements: Screw terminal block models, and pin-style terminal models.
- NEMA4/IP66 compliance
- Six-language instruction manual.



Contents

Ordering Information	5
Specifications	6
Nomenclature	8
Operation	9
Setting Procedure Guide	10
Operation (Timer Function)	11
Operation (Twin Timer Function)	15
Operation in Timer/Twin Timer Selection Mode	19
Timing Charts	20
Dimensions	24
Installation	27
Accessories (Order Separately)	29
Precautions	32
Appendix	35

Ordering Information

Output type	Supply voltage	Models		
		Standard type		Economy type
		Screw terminals	11-pin socket	8-pin socket
Contact output	100 to 240 VAC	H5CX-A	H5CX-A11	H5CX-L8
	12 to 24 VDC/24 VAC	H5CX-AD	H5CX-A11D	H5CX-L8D
Transistor output	100 to 240 VAC	H5CX-AS	H5CX-A11S	H5CX-L8S
	12 to 24 VDC/24 VAC	H5CX-ASD	H5CX-A11SD	H5CX-L8SD

Note: The power supply and input circuits for the H5CX-A11/A11S have basic insulation. Other models are not insulated.

■ Model Number Legend:

H5CX-□□□□□
 1 2 3 4 5

1. Type classifier

- A: Standard type
- L: Economy type

2. External connection

- None: Screw terminals
- 8: 8-pin socket
- 11: 11-pin socket

3. Output type

- None: Contact output
- S: Transistor output

4. Supply voltage

- None: 100 to 240 VAC 50/60 Hz
- D: 12 to 24 VDC/24 VAC 50/60 Hz

5. Case color

- None: Black
- G: Light gray (Munsell 5Y7/1): Produced upon request.

■ Accessories (Order Separately)

Name		Models
Flush Mounting Adapter (See note 1.)		Y92F-30
Waterproof Packing (See note 1.)		Y92S-29
Track Mounting/ Front Connecting Socket	8-pin	P2CF-08
	8-pin, finger-safe type	P2CF-08-E
	11-pin	P2CF-11
	11-pin, finger-safe type	P2CF-11-E
Back Connecting Socket	8-pin	P3G-08
	8-pin, finger-safe type	P3G-08 with Y92A-48G (See note 2.)
	11-pin	P3GA-11
	11-pin, finger-safe type	P3GA-11 with Y92A-48G (See note 2.)
Hard Cover		Y92A-48
Soft Cover		Y92A-48F1
Mounting Track	50 cm (l) × 7.3 mm (t)	PFP-50N
	1 m (l) × 7.3 mm (t)	PFP-100N
	1 m (l) × 16 mm (t)	PFP-100N2
End Plate		PFP-M
Spacer		PFP-S

Note: 1. Supplied with H5CX-A□ models (except for H5CX-A11□ and H5CX-L8□ models).

2. Y92A-48G is a finger-safe terminal cover attached to the P3G-08 or P3GA-11 Socket.

Specifications

■ Ratings

Item	H5CX-A□	H5CX-A11□	H5CX-L8□
Classification	Digital timer		
Rated supply voltage	100 to 240 VAC (50/60 Hz), 24 VAC (50/60 Hz)/12 to 24 VDC (permissible ripple: 20% (p-p) max.)		
Operating voltage range	85% to 110% rated supply voltage (12 to 24 VDC: 90% to 110%)		
Power consumption	Approx. 6.2 VA at 264 VAC Approx. 5.1 VA at 26.4 VAC Approx. 2.4 W at 12 VDC		
Mounting method	Flush mounting	Flush mounting, surface mounting, DIN track mounting	
External connections	Screw terminals	11-pin socket	8-pin socket
Terminal screw tightening torque	0.5 N · m max.	---	
Display	7-segment, negative transmissive LCD; Present value: 11.5-mm-high characters, red or green (programmable) Set value: 6-mm-high characters, green	7-segment, negative transmissive LCD Present value: 11.5-mm-high characters, red Set value: 6-mm-high characters, green	
Digits	4 digits		
Time ranges	9.999 s (0.001 -s unit), 99.99 s (0.01-s unit), 999.9 s (0.1-s unit), 9999 s (1-s unit), 99 min 59 s (1-s unit) 999.9 min (0.1-min unit), 9999 min (1-min unit), 99 h 59 min (1-min unit), 999.9 h (0.1-h unit), 9999 h (1-h unit)		
Timer mode	Elapsed time (Up), remaining time (Down) (selectable)		
Input signals	Start, gate, reset		Start, reset
Input method	No-voltage input/voltage input (switchable) <u>No-voltage Input</u> ON impedance: 1 kΩ max. (Leakage current: 5 to 20 mA when 0 Ω) ON residual voltage: 1 V max. OFF impedance: 100 kΩ min. <u>Voltage Input</u> High (logic) level: 4.5 to 30 VDC Low (logic) level: 0 to 2 VDC (Input resistance: approx. 4.7 kΩ)		<u>No-voltage Input</u> ON impedance: 1 kΩ max. (Leakage current: 5 to 20 mA when 0 Ω) ON residual voltage: 1 V max. OFF impedance: 100 kΩ min.
Start, reset, gate	Minimum input signal width: 1 or 20 ms (selectable, same for all input)		
Power reset	Minimum power-opening time: 0.5 s (except for A-3, b-1, and F mode)		
Reset system	Power resets (except for A-3, b-1, and F modes), external and manual reset		
Sensor waiting time	260 ms max. (Control output is turned OFF and no input is accepted during sensor waiting time.)		
Output modes	A, A-1, A-2, A-3, b, b-1, d, E, F, Z, ton or toff		
One-shot output time	0.01 to 99.99 s		
Control output	SPDT contact output: 5 A at 250 VAC, resistive load (cosφ=1) Minimum applied load: 10 mA at 5 VDC (failure level: P, reference value) Transistor output: NPN open collector, 100 mA at 30 VDC max. residual voltage: 1.5 VDC max. (Approx. 1 V) Conforms to EN60947-5-1 for Timers with Contact Outputs and EN60947-5-2 for Timers with Transistor Outputs. NEMA B300 Pilot Duty, 1/4 HP 5-A resistive load at 120 VAC, 1/3 HP 5-A resistive load at 240 VAC		
Key protection	Yes		
Memory backup	EEPROM (overwrites: 100,000 times min.) that can store data for 10 years min.		
Ambient temperature	Operating: -10 to 55°C (-10 to 50°C if timers are mounted side by side) (with no icing or condensation) Storage: -25 to 65°C (with no icing or condensation)		
Ambient humidity	25% to 85%		
Case color	Black (N1.5)		
Attachments	Waterproof packing, flush mounting adapter	None	

■ Characteristics

Item	H5CX-A□/-A11□/-L8□
Accuracy of operating time and setting error (including temperature and voltage influences) (See note 1.)	Power-ON start: $\pm 0.01\% \pm 50$ ms max. Rated against set value Signal start: $\pm 0.005 \pm 30$ ms max. Rated against set value Signal start for transistor output model: $\pm 0.005\% \pm 3$ ms max. (See note 2.) If the set value is within the sensor waiting time at startup the control output of the H5CX will not turn ON until the sensor waiting time passes.
Insulation resistance	100 M Ω min. (at 500 VDC) between current-carrying terminal and exposed non-current-carrying metal parts, and between non-continuous contacts
Dielectric strength	2,000 VAC, 50/60 Hz for 1 min between current-carrying terminals and non-current-carrying metal parts 1,000 VAC, 50/60 Hz for 1 min between non-continuous contacts
Impulse withstand voltage	3 kV (between power terminals) for 100 to 240 VAC, 1 kV for 24 VAC/12 to 24 VDC 4.5 kV (between current-carrying terminal and exposed non-current-carrying metal parts) for 100 to 240 VAC 1.5 kV for 24 VAC/12 to 24 VDC
Noise immunity	± 1.5 kV (between power terminals) for 100 to 240 VAC, ± 480 V for 24 VAC/12 to 24 VDC, and ± 600 V (between input terminals), square-wave noise by noise simulator (pulse width: 100 ns/1 ms, 1-ns rise)
Static immunity	Destruction: 15 kV Malfunction: 8 kV
Vibration resistance	Destruction: 10 to 55 Hz with 0.75-mm single amplitude each in three directions Malfunction: 10 to 55 Hz with 0.35-mm single amplitude each in three directions
Shock resistance	Destruction: 294 m/s ² each in three directions Malfunction: 98 m/s ² each in three directions
Life expectancy	Mechanical: 10,000,000 operation min. Electrical: 100,000 operations min. (5 A at 250 VAC, resistive load)
Approved safety standards (See note 3.)	UL508 (H5CX-A□/-A11□: Recognition, H5CX-L8□ with P2CF-08-□ or P3G-08 Socket: Listing), CSA C22.2 No. 14, conforms to EN61010-1 (Pollution degree 2/overvoltage category II) Conforms to VDE0106/P100 (finger protection).
EMC	(EMI) Emission Enclosure: EN61326 Emission AC mains: EN55011 Group 1 class A (EMS) Immunity ESD: EN61326 EN61000-4-2: 4 kV contact discharge (level 2) 8 kV air discharge (level 3) Immunity RF-interference: EN61000-4-3: 10 V/m (Amplitude-modulated, 80 MHz to 1 GHz) (level 3); 10 V/m (Pulse-modulated, 900 MHz ± 5 MHz) (level 3) Immunity Conducted Disturbance: EN61000-4-6: 10 V (0.15 to 80 MHz) (according to EN61000-6-2) Immunity Burst: EN61000-4-4: 2 kV power-line (level 3); 1 kV I/O signal-line (level 4) Immunity Surge: EN61000-4-5: 1 kV line to lines (power and output lines) (level 3); 2 kV line to ground (power and output lines) (level 3) 1 kV line to ground (I/O signal line) Immunity Voltage Dip/Interruption EN61000-4-11: 0.5 cycle, 100% (rated voltage)
Degree of protection	Panel surface: IP66 and NEMA Type 4 (indoors) (See note 4.)
Weight	H5CX-A□: Approx. 135 g, H5CX-A11□/-L8□: Approx. 105 g

- Note:**
1. The values are based on the set value.
 2. The value is applied for a minimum pulse width of 1 ms.
 3. To meet UL listing requirements with the H5CX-L8□, an OMRON P2CF-08-□ or P3G-08 Socket must be mounted on the Timer.
 4. A waterproof packing is necessary to ensure IP66 waterproofing between the H5CX and installation panel.

■ Engineering Data (Reference Values)

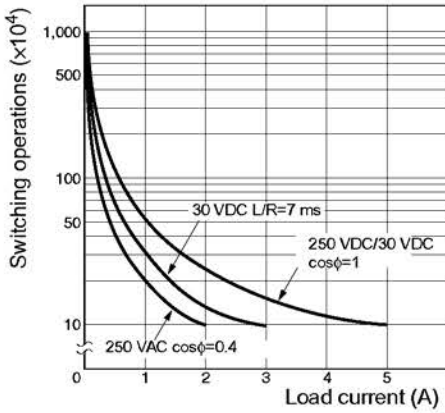

Reference: A maximum current of 0.15 A can be switched at 125 VDC (cosφ=1) and a maximum current of 0.1 A can be switched if L/R is 7 ms. In both cases, a life of 100,000 operations can be expected. The minimum applicable load is 10 mA at 5 VDC (failure level: P).

Nomenclature

- | Indicator |
|---|
| ① Reset Indicator (orange) |
| ② Key Protection Indicator (orange) |
| ③ Control Output Indicator (orange) |
| ④ Present Value
(red or green (programmable) for H5CX-A models, red for H5CX-A11 /-L models)
Character height: 11.5 mm |
| ⑤ Time Unit Display (orange):
(If the time range is 0 min, 0 h, 0.0 h, or 0 h 0 min, this display flashes to indicate timing operation.) |
| ⑥ Set Value (green)
Character height: 6 mm |
| ⑦ Set Value 1, 2 Display |



- | Operation Key |
|--|
| ⑧ Mode Key
(Changes modes and setting items) |
| ⑨ Reset Key
(Resets present value and output) |
| ⑩ Up Keys 1 to 4 |
| ⑪ Down Keys 1 to 4 |

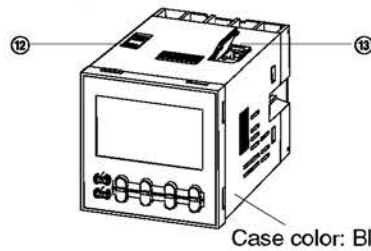

- | Switches |
|--|
| ⑫ Key-protect Switch
(default setting) OFF ← → ON |
| ⑬ DIP Switch |

Operation

■ Block Diagram

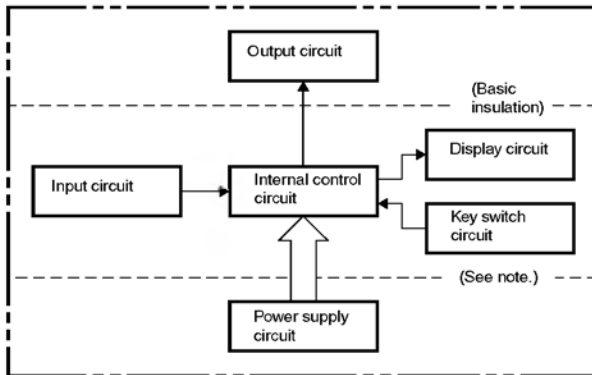

Note: Power circuit is not insulated from the input circuit, except for H5CX-A11/A11S, which have basic insulation.

■ I/O Functions

Inputs	Start signal	Stops timing in A-2 and A-3 (power ON delay) modes. Start timing in other modes.
	Reset	Resets present value. (In elapsed time mode, the present value returns to 0; in remaining time mode, the present value returns to the set value.) Count inputs are not accepted and control output turns OFF while reset input is ON. Reset indicator is lit while reset input is ON.
	Gate	Inhibits timer operation.
Outputs	Control output (OUT)	Outputs take place according to designated operating mode when timer reaches corresponding set value.

Setting Procedure Guide

■ Settings for Timer Operation

Use the following settings for all models except the H5CX-L8□.
Refer to page 12 for the H5CX-L8□.

When Using Basic Functions Only

Basic Functions

- Time range (0.001 s to 999.9 h, except 9,999 h and 9,999 min)
- Output mode (A, A-2, E, F)
- Timer mode (UP/DOWN)
- Input signal width (20 ms/1 ms)

The settings can be performed easily with the DIP switch.
➔For details on the setting methods, refer to page 11.

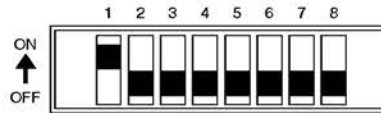

When Using Other Time Ranges (9,999 h, 9,999 min) and Output Modes (A-1, A-3, b, b-1, d, and Z)

All the functions can be set with the operation keys.
➔For details on the setting methods, refer to page 12.

When Using More Detailed Setting Items (Output Time, NPN/PNP Input Mode, Display Color, Key Protect Level)

Setting for items other than the basic functions can be performed with the operation keys.
➔For details on the setting methods, refer to page 12.

Note: At the time of delivery, the H5CX is set for timer operation.

■ Settings for Twin Timer Operation

Use the following settings for all models except the H5CX-L8□.
Refer to page 16 for the H5CX-L8□.

When Using Basic Functions Only

Basic Functions

- Time range (0.01 s to 99 min 59 s)
- ON/OFF start mode (flicker OFF start/flicker ON start)
- Timer mode (UP/DOWN)
- Input signal width (20 ms/1 ms)

The settings can be performed easily with the DIP switch.
➔For details on the setting methods, refer to page 15.

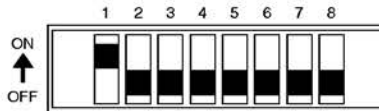

When Using Other Time Ranges (999.9 min, 9,999 min, 99 h 59 min, 999.9 h, 9,999 h, 9,999 s)

All the functions can be set with the operation keys.
➔For details on the setting methods, refer to page 16.

When Using More Detailed Setting Items (NPN/PNP Input Mode, Display Color, Key Protect Level)

Setting for items other than the basic functions can be performed with the operation keys.
➔For details on the setting methods, refer to page 16.

Note: At the time of delivery, the H5CX is set for timer operation.

Operation (Timer Function)

■ Settings for Basic Functions

Settings for basic functions can be performed with just the DIP switch.

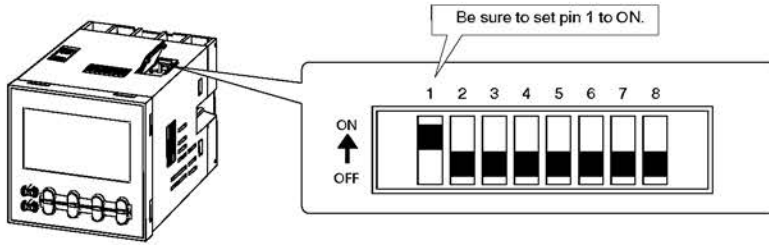

	Item	OFF	ON
1	DIP switch settings enable/disable	Disabled	Enabled
2	Time range	Refer to the table on the right.	
3			
4			
5	Output mode	Refer to the table on the right.	
6			
7	Timer mode	Elapsed time (UP)	Remaining time (DOWN)
8	Input signal width	20 ms	1 ms

Pin 2	Pin 3	Pin 4	Time range
ON	ON	ON	0.001 s to 9.999 s
OFF	OFF	OFF	0.01 s to 99.99 s
ON	OFF	OFF	0.1 s to 999.9 s
OFF	ON	OFF	1 s to 9999 s
ON	ON	OFF	0 min 01 s to 99 min 59 s
OFF	OFF	ON	0.1 min to 999.9 min
ON	OFF	ON	0 h 01 min to 99 h 59 min
OFF	ON	ON	0.1 h to 999.9 h

Note: All the pins are factory-set to OFF.

Easy Confirmation of Switch Settings Using Indicators
 The ON/OFF status of the DIP switch pins can be confirmed using the front display. For details, refer to page 19.

Pin 5	Pin 6	Output mode
OFF	OFF	A mode (signal ON delay (I): power reset operation)
ON	OFF	A-2 mode: (power ON delay (I): power reset operation)
OFF	ON	E mode (interval: power reset operation)
ON	ON	F mode (accumulative: power hold operation)

- Note:**
1. Be sure to set pin 1 of the DIP switch to ON. If it is set to OFF, the DIP switch settings will not be enabled.
 2. Changes to DIP switch settings are enabled when the power is turned ON. (Perform DIP switch settings while the power is OFF.)
 3. There is no DIP switch on the H5CX-L8□. For details on the setting methods, refer to page 12.
 4. When using time ranges or output modes that cannot be set with the DIP switch, all of the settings have to be made using the operation keys. For details on the setting methods, refer to page 12.



Detailed Settings
 After making DIP switch settings for basic functions, detailed settings (see note) can be added using the operation keys. For details, refer to page 12.
Note: Key protect level, output time, display color, NPN/PNP input mode.

■ Explanation of Functions

Time Range ($t_{\bar{c}rr}$) (Setting possible using DIP switch.)

Set the range to be timed in the range 0.000 s to 9,999 h. Settings of type — h (9,999 h) and — min (9,999 min) cannot, however, be made with the DIP switch. Use the operation keys if these settings are required.

Timer Mode ($t_{\bar{c}r\bar{n}}$) (Setting possible using DIP switch.)

Set either the elapsed time (UP) or remaining time (DOWN) mode.

Output Mode ($\bar{a}l\bar{t}\bar{n}$) (Setting possible using DIP switch.)

Set the output mode. The possible settings are A, A-1, A-2, A-3, b, b-1, d, E, F, and Z. Only output modes A, A-2, E, and F can be set using the DIP switch. Use the operation keys if a different setting is required. (For details on output mode operation, refer to *Timing Charts* on page 20.)

Output Time ($\bar{a}l\bar{c}\bar{n}$)

When using one-shot output, set the output time for one-shot output (0.01 to 99.99 s). One-shot output can be used only if the selected output mode is A, A-1, A-2, b, or b-1. If the output time is set to 0.00, *HOLD* is displayed, and the output is held.

Input Signal Width ($\bar{c}FL\bar{E}$) (Setting possible using DIP switch.)

Set the minimum signal input width (20 ms or 1 ms) for signal, reset, and gate inputs. The same setting is used for all external inputs (signal, reset, and gate inputs). If contacts are used for the input signal, set the input signal width to 20 ms. Processing to eliminate chattering is performed for this setting.

NPN/PNP Input Mode ($\bar{c}n\bar{a}d$)

Select either NPN input (no-voltage input) or PNP input (voltage input) as the input format. The same setting is used for all external inputs. For details on input connections, refer to *Input Connections* on page 28.

Display Color ($\bar{c}aLr$)

Set the color used for the present value.

rEd The present value is displayed in red.

$\bar{E}r\bar{n}$ The present value is displayed in green.

$r\bar{E}$ The present value is displayed in red when the control output is OFF, and is displayed in green when the control output is ON.

$\bar{E}r$ The present value is displayed in green when the control output is OFF, and is displayed in red when the control output is ON.

Key Protect Level ($\bar{c}uPl$)

Set the key protect level.

When the key-protect switch is set to ON, it is possible to prevent setting errors by prohibiting the use of certain operation keys by specifying the key protect level (KP-1 to KP-5). The key protect indicator is lit while the key-protect switch is set to ON. Confirm the ON/OFF status of the key-protect switch after the H5CX is mounted to the panel.

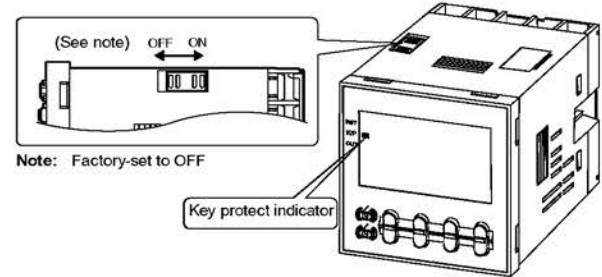

Level	Meaning
KP-1 (default setting)	<p>Prohibits changing the mode to timer/twin timer selection mode or function setting mode. The H5CX can only be used in run mode.</p>
KP-2	<p>Prohibits changing the mode to timer/twin timer selection mode or function setting mode. The H5CX can only be used in run mode. Also prohibits use of the reset key.</p>
KP-3	<p>Prohibits changing the mode to timer/twin timer selection mode or function setting mode. The H5CX can only be used in run mode. Also prohibits use of the up and down keys.</p>
KP-4	<p>Prohibits changing the mode to timer/twin timer selection mode or function setting mode. The H5CX can only be used in run mode. Also prohibits use of the reset, up and down keys.</p>
KP-5	<p>Prohibits changing the mode to timer/twin timer selection mode or function setting mode. The H5CX can only be used in run mode. Also prohibits use of any operation keys.</p>

■ Operation in Run Mode

When Output Mode Is Not Z

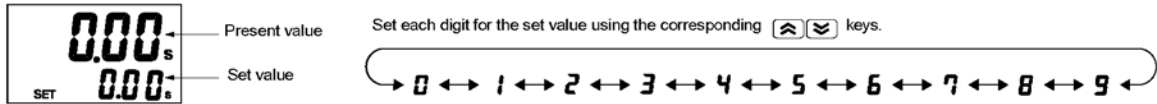

Set each digit for the set value using the corresponding keys.

When Output Mode Z Is Selected

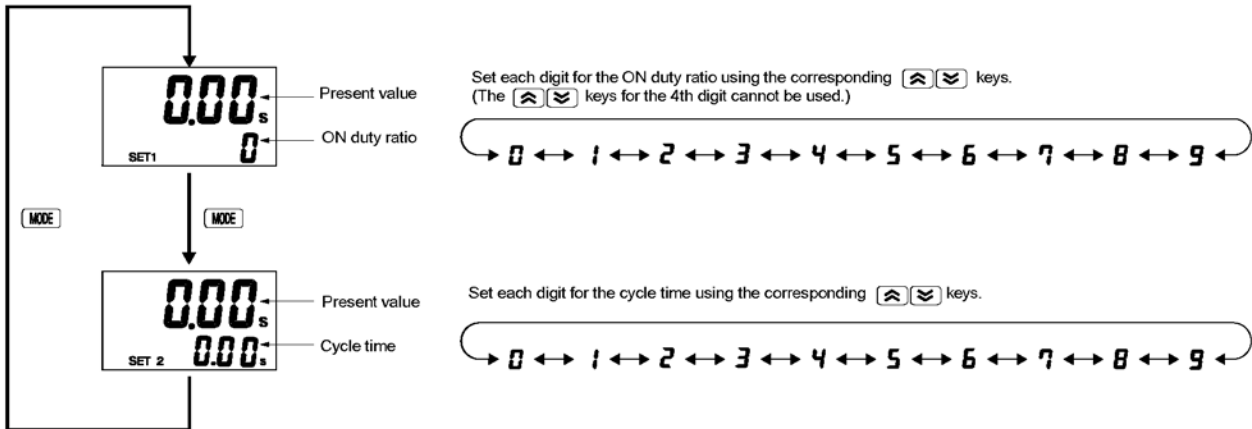

Set each digit for the ON duty ratio using the corresponding keys. (The keys for the 4th digit cannot be used.)

Set each digit for the cycle time using the corresponding keys.

Present Value and Set Value

These items are displayed when the power is turned ON. The present value is displayed in the main display and the set value is displayed in the sub-display. The values displayed will be determined by the settings made for the time range and the timer mode in function setting mode.

Present Value and ON Duty Ratio (Output Mode = Z)

The present value is displayed in the main display and the ON duty ratio is displayed in the sub-display. "SET1" lights at the same time.

Set the ON duty ratio used in ON/OFF-duty adjustable flicker mode (Z) as a percentage.

If a cycle time is set, cyclic control can be performed in ON/OFF-duty adjustable flicker mode simply by changing the ON duty ratio.

Present Value and Cycle Time (Output Mode = Z)

The present value is displayed in the main display and the cycle time is displayed in the sub-display. "SET2" lights at the same time.

Set the cycle time used in ON/OFF-duty adjustable flicker mode (Z).

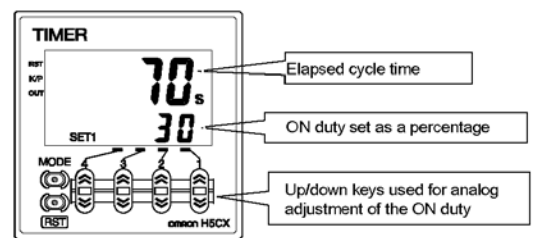

Operation (Twin Timer Function)

■ Switching from Timer to Twin Timer

The H5CX is factory-set for timer operation. To switch to twin timer operation, use the procedure given below. For details, refer to page 35.

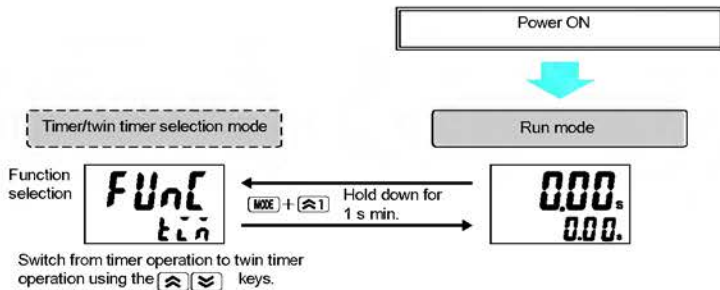

■ Settings for Basic Functions

Settings for basic functions can be performed with just the DIP switch.

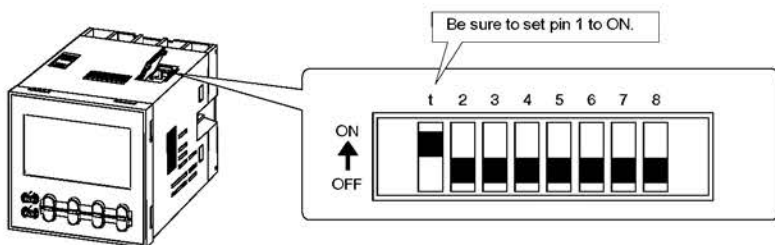

	Item	OFF	ON
1	DIP switch settings enable/disable	Disabled	Enabled
2	OFF time range	Refer to the table on the right.	
3			
4	ON time range	Refer to the table on the right.	
5			
6	ON/OFF start mode	Flicker OFF start	Flicker ON start
7	Timer mode	UP	DOWN
8	Input signal width	20 ms	1 ms

Pin 2	Pin 3	OFF time range
OFF	OFF	0.01 s to 99.99 s
ON	OFF	0.1 s to 999.9 s
OFF	ON	1 s to 9,999 s
ON	ON	0 min 01 s to 99 min 59 s

Pin 4	Pin 5	ON time range
OFF	OFF	0.01 s to 99.99 s
ON	OFF	0.1 s to 999.9 s
OFF	ON	1 s to 9,999 s
ON	ON	0 min 01 s to 99 min 59 s

Note: All the pins are factory-set to OFF.

Easy Confirmation of Switch Settings Using Indicators
The ON/OFF status of the DIP switch pins can be confirmed using the front display. For details, refer to page 19.

- Note:**
1. Be sure to set pin 1 of the DIP switch to ON. If it is set to OFF, the DIP switch settings will not be enabled.
 2. Changes to DIP switch settings are enabled when the power is turned ON. (Perform DIP switch settings while the power is OFF.)
 3. There is no DIP switch on the H5CX-L8□. For details on the setting methods, refer to page 16.
 4. When using time ranges or output modes that cannot be set with the DIP switch, all of the settings have to be made using the operation keys. For details on the setting methods, refer to page 16.

Detailed Settings
After making DIP switch settings for basic functions, detailed settings (see note) can be added using the operation keys. For details, refer to page 12.
Note: Key protect level, output time, display color, NPN/PNP input mode.

Settings for Advanced Functions

Settings that cannot be performed with the DIP switch are performed with the operation keys.

Power ON

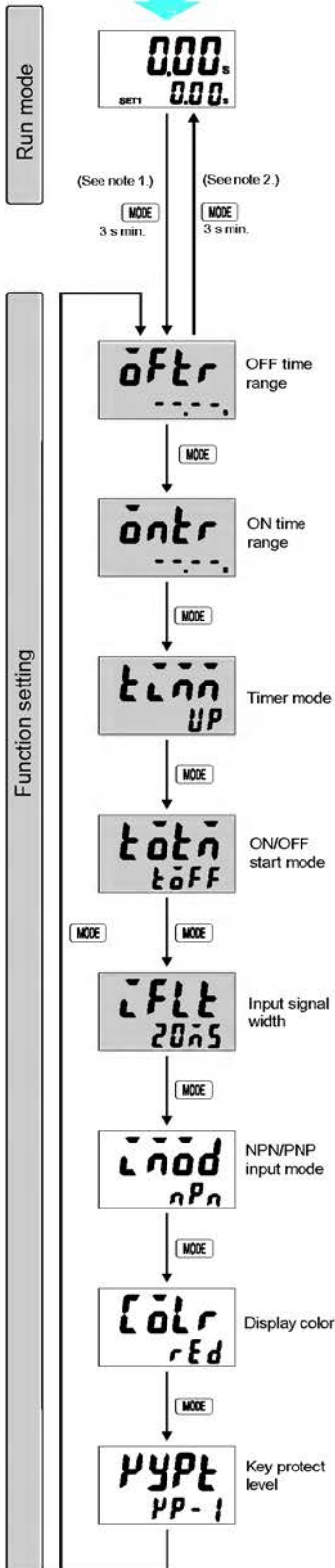

For details on operations in run mode, refer to page 18.

- Note:**
1. If the mode is switched to the function setting mode during operation, operation will continue.
 2. Changes made to settings in function setting mode are enabled for the first time when the mode is changed to run mode. Also, when settings are changed, the timer is reset (time initialized and output turned OFF).

The characters displayed in reverse video are the initial values.
 (When performing settings with operation keys only, set pin1 of the DIP switch to OFF (factory setting). If pin 1 of the DIP switch is set to ON, the setting items indicated by will not be displayed.)

Set the OFF time range using the keys.

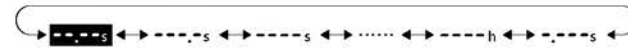

For details, refer to *Time Range List*, below

Set the ON time range using the keys.

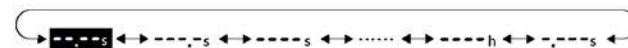

For details, refer to *Time Range List*, below.

Set the timer mode using the keys.

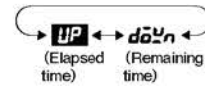

Set the twin timer output mode using the keys.



Set the input signal width using the keys.



Set the NPN/PNP input mode using the keys.

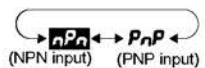

Only displayed for H5CX-A□ and H5CX-A11□ models.

Set the display color using the keys.

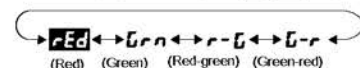

Displayed for terminal-block models (H5CX-A□) only.

Set the key protect level using the keys.

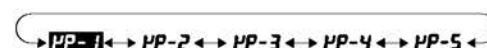

Time Range List

Display	Set Value
	0.01 s to 99.99 s (default setting)
	0.1 s to 999.9 s
	1 s to 9,999 s
	0 min 01 s to 99 min 59 s
	0.1 min to 999.9 min
	1 min to 9,999 min
	0 h 01 min to 99 h 59 min
	0.1 h to 999.9 h
	1 h to 9,999 h
	0.001 s to 9.999 s

■ Explanation of Functions

OFF Time Range (OFFLr) (Setting possible using DIP switch.)

Set the time range for the OFF time in the range 0.000 s to 9,999 h. Only settings of type --. s (99.99 s), --. s (999.9 s), --- s (9,999 s), and -- min -- s (99 min 59 s), however, can be made with the DIP switch. Use the operation keys if another type of setting is required.

ON Time Range (ONLr) (Setting possible using DIP switch.)

Set the time range for the ON time in the range 0.000 s to 9,999 h. Only settings of type --. s (99.99 s), --. s (999.9 s), --- s (9,999 s), and -- min -- s (99 min 59 s), however, can be made with the DIP switch. Use the operation keys if another type of setting is required.

Timer Mode (Lr) (Setting possible using DIP switch.)

Set either UP (incremental) or DOWN (decremental) timer mode. In UP mode, the elapsed time is displayed, and in DOWN mode, the remaining time is displayed.

ON/OFF Start Mode (Lr) (Setting possible using DIP switch.)

Set the output mode. Set either flicker OFF start or flicker ON start. (For details on output mode operation, refer to *Timing Charts* on page 20.)

Input Signal Width (Lr) (Setting possible using DIP switch.)

Set the minimum signal input width (20 ms or 1 ms) for signal, reset, and gate inputs. The same setting is used for all external inputs (signal, reset, and gate inputs). If contacts are used for the input signal, set the input signal width to 20 ms. Processing to eliminate chattering is performed for this setting.

NPN/PNP Input Mode (Lr)

Select either NPN input (no-voltage input) or PNP input (voltage input) as the input format. The same setting is used for all external inputs. For details on input connections, refer to *Input Connections* on page 28.

Display Color (Lr)

Set the color used for the present value.

rEd The present value is displayed in red.

Grn The present value is displayed in green.

r-G The present value is displayed in red when the control output is OFF, and is displayed in green when the control output is ON.

G-r The present value is displayed in green when the control output is OFF, and is displayed in red when the control output is ON.

Key Protect Level (Lr)

Set the key protect level.

When the key-protect switch is set to ON, it is possible to prevent setting errors by prohibiting the use of certain operation keys by specifying the key protect level (KP-1 to KP-5). The key protect indicator is lit while the key-protect switch is set to ON. Confirm the ON/OFF status of the key-protect switch after the H5CX is mounted to the panel.

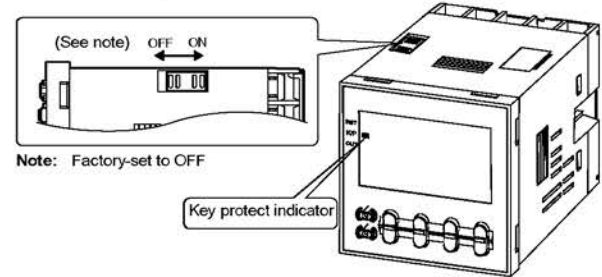

Level		Meaning
KP-1 (default setting)		Prohibits changing the mode to timer/twin timer selection mode or function setting mode. The H5CX can only be used in run mode.
KP-2		Prohibits changing the mode to timer/twin timer selection mode or function setting mode. The H5CX can only be used in run mode. Also prohibits use of the reset key.
KP-3		Prohibits changing the mode to timer/twin timer selection mode or function setting mode. The H5CX can only be used in run mode. Also prohibits use of the up and down keys.
KP-4		Prohibits changing the mode to timer/twin timer selection mode or function setting mode. The H5CX can only be used in run mode. Also prohibits use of the reset, up and down keys.
KP-5		Prohibits changing the mode to timer/twin timer selection mode or function setting mode. The H5CX can only be used in run mode. Also prohibits use of any operation keys.

■ Operation in Run Mode

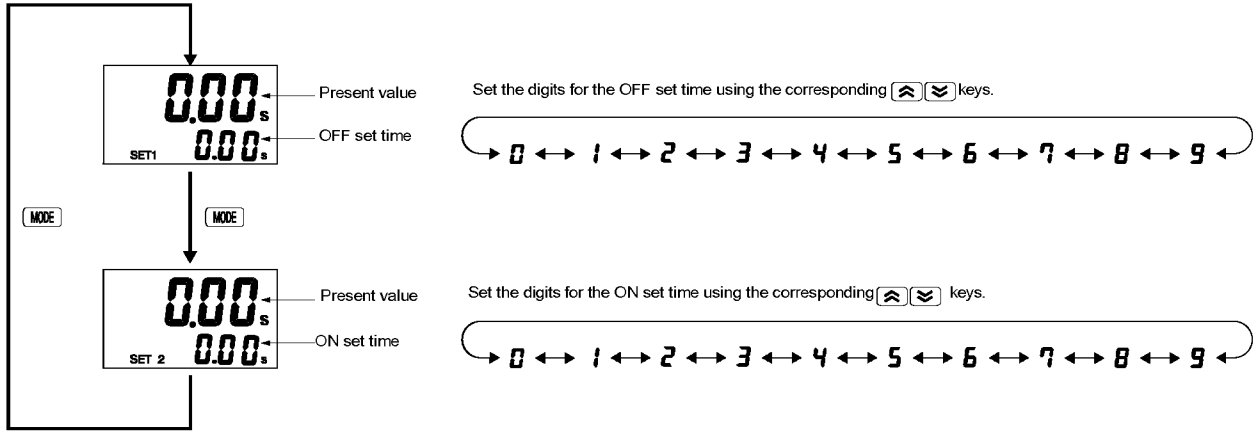

Present Value and OFF Set Time

The present value is displayed in the main display and the OFF set time is displayed in the sub-display. "SET1" lights at the same time.

Present Value and ON Set Time

The present value is displayed in the main display and the ON set time is displayed in the sub-display. "SET2" lights at the same time.

Operation in Timer/Twin Timer Selection Mode

Select whether the H5CX is used as a timer or a twin timer in timer/twin timer selection mode. The H5CX is also equipped with a DIP switch monitor function, a convenient function that enables the settings of the DIP switch pins to be confirmed using the front display.

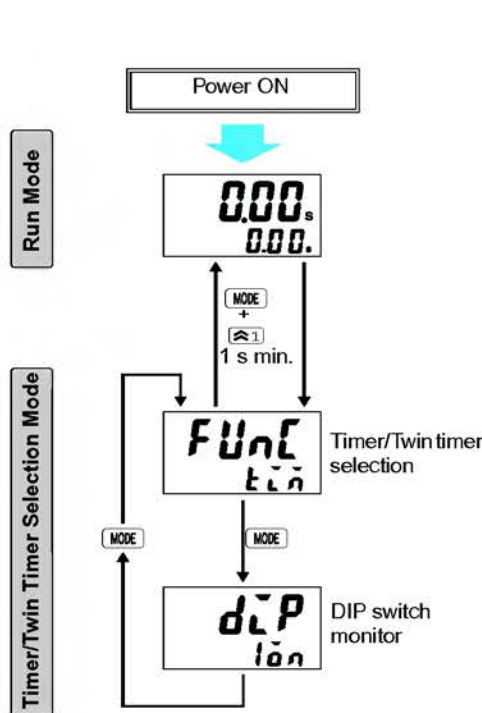

To change the mode to timer/twin timer selection mode, hold down the [1] key for 1 s min. with the [MODE] key held down. The [MODE] key must be pressed before the [1] key. If the [1] key is pressed first, the mode will not change.

Select either timer operation or twin timer operation using the [] [] keys.

Note: The H5CX is factory-set for timer operation.

Confirm the status of DIP switch pins 1 to 8 using the [] [] keys.

- Note:**
1. This display is not supported with H5CX-L8□.
 2. This display is only possible when DIP switch pin 1 (DIP switch settings enable/disable) is set to ON (enable).

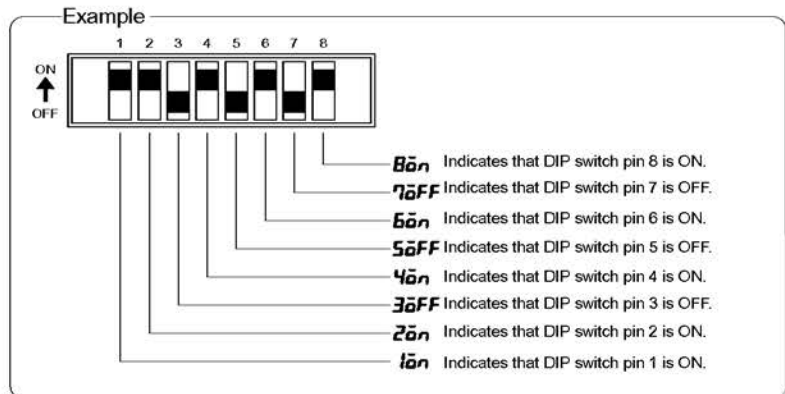

- Note:**
1. When the mode is changed to timer/twin timer selection mode, the present value is reset and output turns OFF. Timing operation is not performed in timer/twin timer selection mode.
 2. Setting changes made in timer/twin timer selection mode are enabled when the mode is changed to run mode. If settings are changed, the H5CX is automatically reset (present value initialized, output turned OFF).

Timing Charts

■ Timer Operation

The gate input is not included in the H5CX-L8□ models.

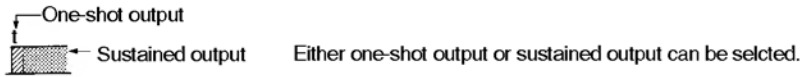

Output mode A: Signal ON delay 1 (Timer resets when power comes ON.)	
	<p>Timing starts when the start signal goes ON. While the start signal is ON, the timer starts when the power comes ON or when the reset input goes OFF. The control output is controlled using a sustained or one-shot time period.</p> <p>Basic Operation</p> <p>* Output is instantaneous when setting is 0. ** Start signal input is disabled during timing.</p>
Output mode A-1: Signal ON delay 2 (Timer resets when power comes ON.)	
	<p>Timing starts when the start signal goes ON, and is reset when the start signal goes OFF. While the start signal is ON, the timer starts when the power comes ON or when the reset input goes OFF. The control output is controlled using a sustained or one-shot time period.</p> <p>Basic Operation</p> <p>*Output is instantaneous when setting is 0.</p>
Output mode A-2: Power ON delay 1 (Timer resets when power comes ON.)	
	<p>Timing starts when the reset input goes OFF. The start signal disables the timing function (i.e., same function as the gate input). The control output is controlled using a sustained or one-shot time period.</p> <p>Basic Operation</p> <p>*Output is instantaneous when setting is 0.</p>
Output mode A-3: Power ON delay 2 (Timer does not reset when power comes ON.)	
	<p>Timing starts when the reset input goes OFF. The start signal disables the timing function (i.e., same function as the gate input). The control output is controlled using a sustained or one-shot time period.</p> <p>Basic Operation</p> <p>*Output is instantaneous when setting is 0.</p>

Output mode b: Repeat cycle 1 (Timer resets when power comes ON.)

Sustained Output

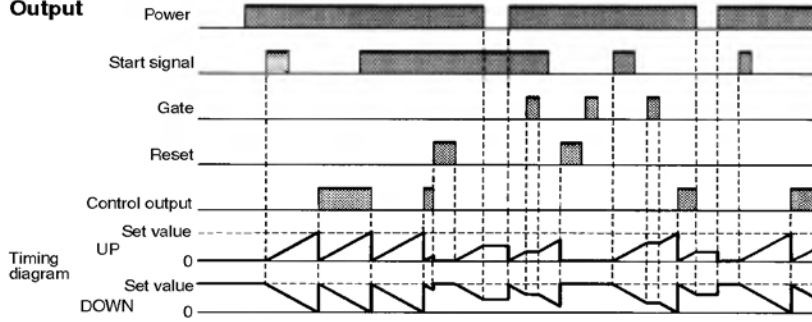

Timing diagram

Timing starts when the start signal goes ON. The status of the control output is reversed when time is up (OFF at start). While the start signal is ON, the timer starts when the power comes ON or when the reset input goes OFF.

Basic Operation

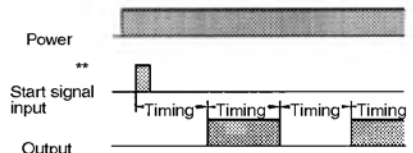

- * Normal output operation will not be possible if the set time is too short. Set the value to at least 100 ms (contact output type).
- ** Start signal input is disabled during timing.

One-shot Output

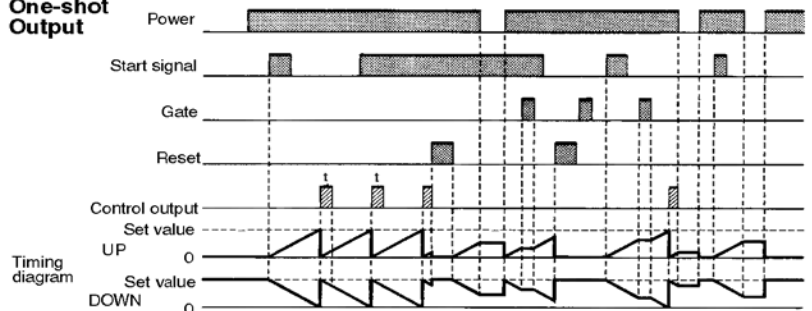

Timing diagram

Timing starts when the start signal goes ON. The control output is turned ON when time is up. While the start signal is ON, the timer starts when the power comes ON or when the reset input goes OFF.

Basic Operation

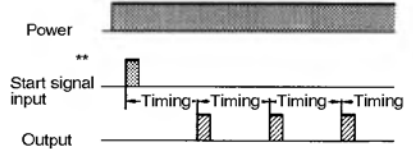

- * Normal output operation will not be possible if the set time is too short. Set the value to at least 100 ms (contact output type).
- ** Start signal input is disabled during timing.

Output mode b-1: Repeat cycle 2 (Timer does not reset when power comes ON.)

Sustained Output

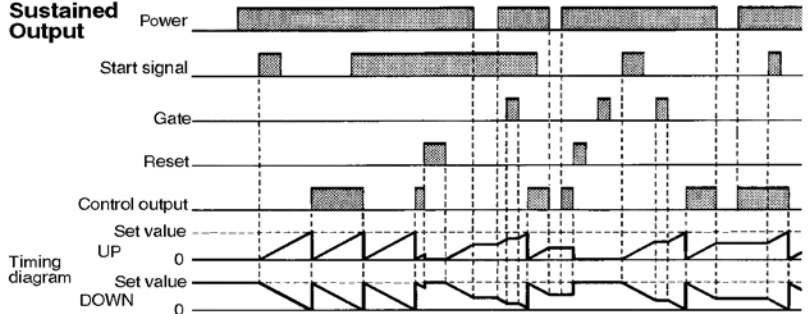

Timing diagram

Timing starts when the start signal goes ON. The status of the control output is reversed when time is up (OFF at start). While the start signal is ON, the timer starts when the power comes ON or when the reset input goes OFF.

Basic Operation

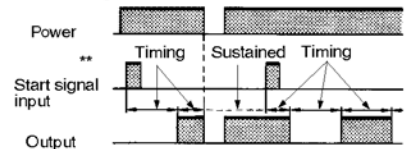

- * Normal output operation will not be possible if the set time is too short. Set the value to at least 100 ms (contact output type).
- ** Start signal input is disabled during timing.

One-shot Output

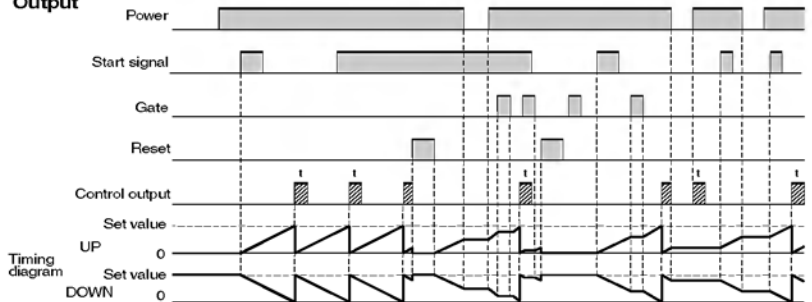

Timing diagram

Timing starts when the start signal goes ON. The control output comes ON when time is up. While the start signal is ON, the timer starts when the power comes ON or when the reset input goes OFF.

Basic Operation

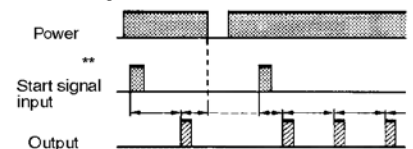

- * Normal output operation will not be possible if the set time is too short. Set the value to at least 100 ms (contact output type).
- ** Start signal input is disabled during timing.

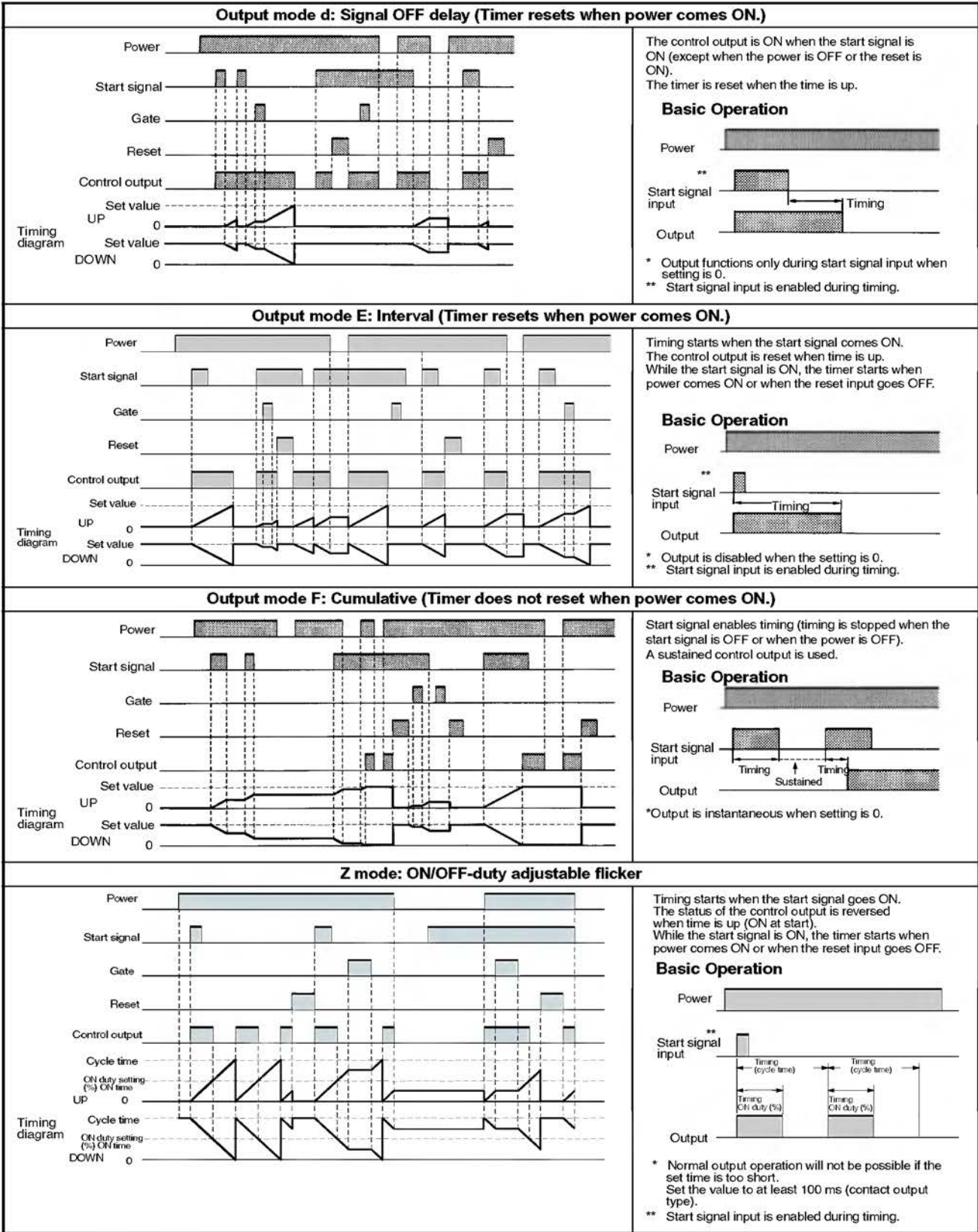

Z Mode

Output quantity can be adjusted by changing the cycle time set in the adjustment level to 1 and by changing the ON duty (%) set value. The set value shows the ON duty (%) and can be set to a value between 0 and 100 (%). When the cycle time is 0, the output will always be OFF. When the cycle time is not 0 and when ON duty has been set to 0 (%), the output will always be OFF. When ON duty has been set to 100 (%), the output will always be ON.

■ Twin Timer Operation

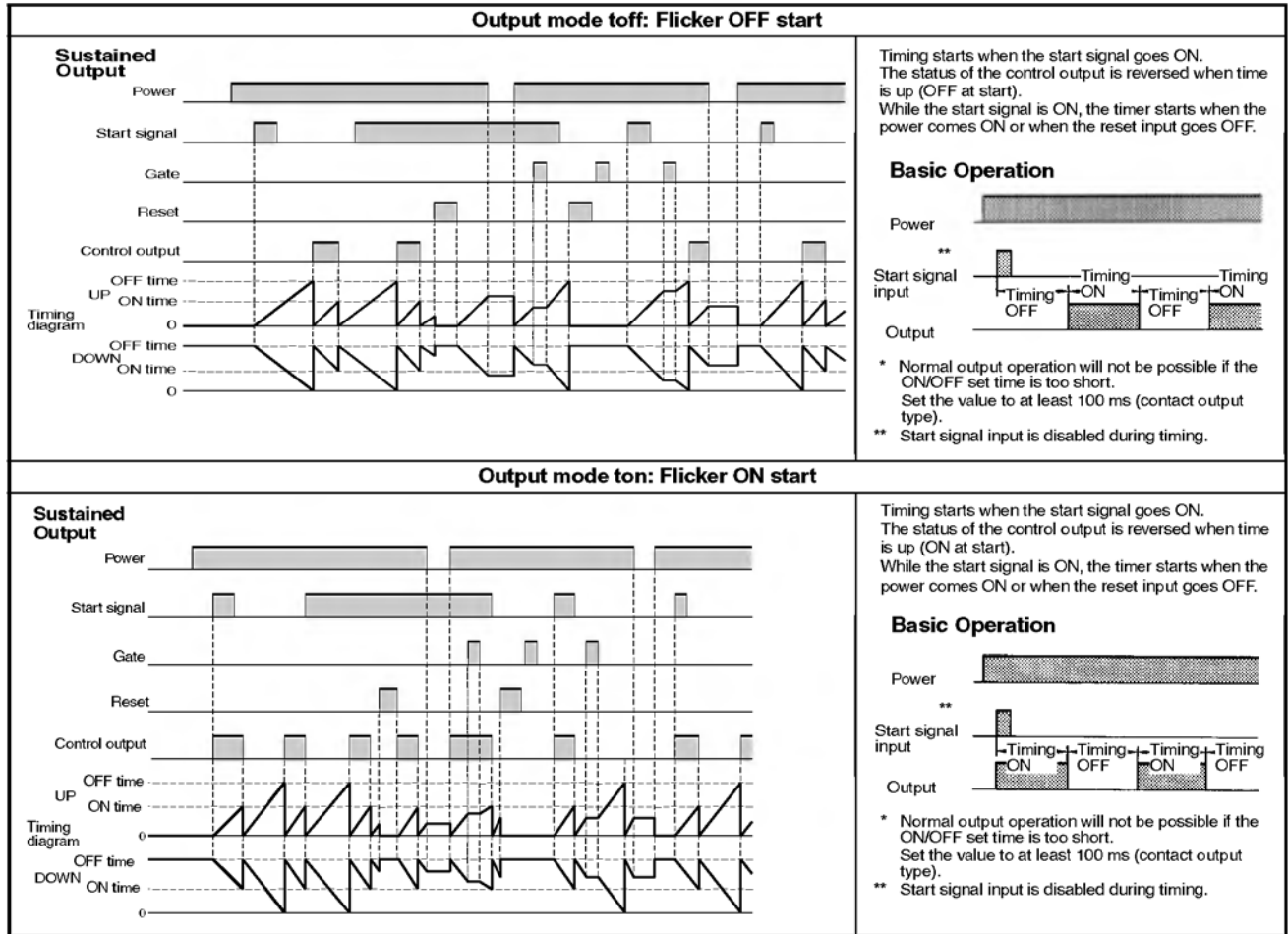

Dimensions

Note: All units are in millimeters unless otherwise indicated.

■ Timer (without Flush Mounting Adapter)

H5CX-A/-AS (Flush Mounting)

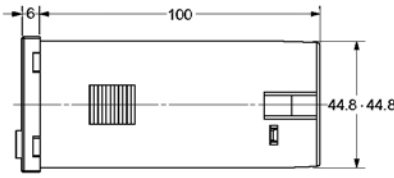
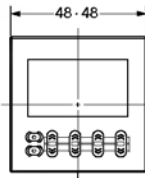

Note: M3.5 terminal screw (effective length: 6 mm)

H5CX-AD/-ASD (Flush Mounting)

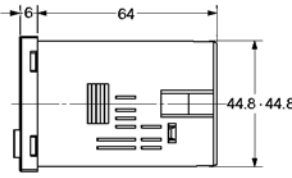
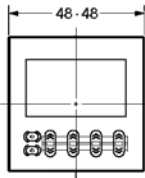

Note: M3.5 terminal screw (effective length: 6 mm)

H5CX-A11/-A11S (Flush Mounting/Surface Mounting)

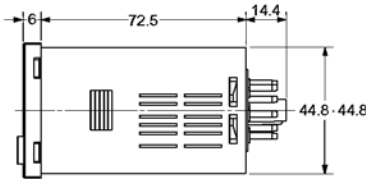
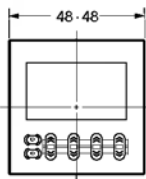

H5CX-A11D/-A11SD (Flush Mounting/Surface Mounting)

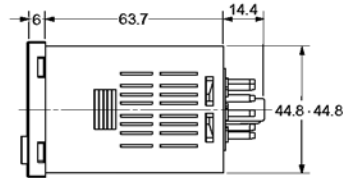
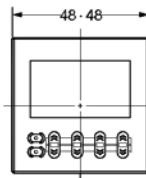

H5CX-L8□ (Flush Mounting/Surface Mounting)

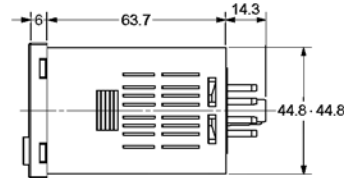
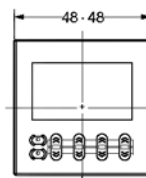

■ Dimensions with Flush Mounting Adapter

H5CX-A/-AS (Provided with Adapter and Waterproof Packing)

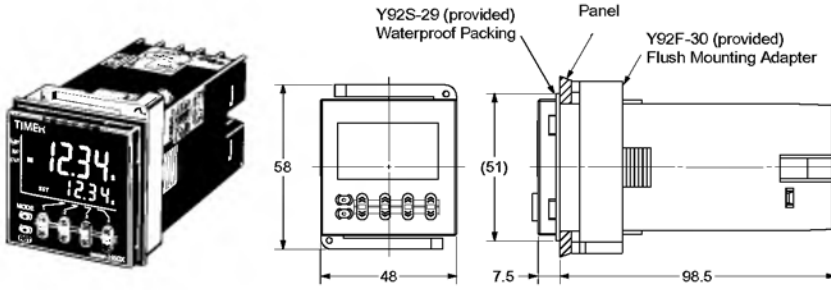

H5CX-AD/-ASD (Provided with Adapter and Waterproof Packing)

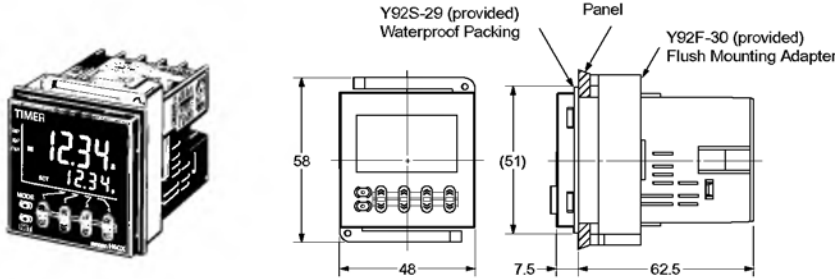

H5CX-A11/-A11S (Adapter and Waterproof Packing Ordered Separately)

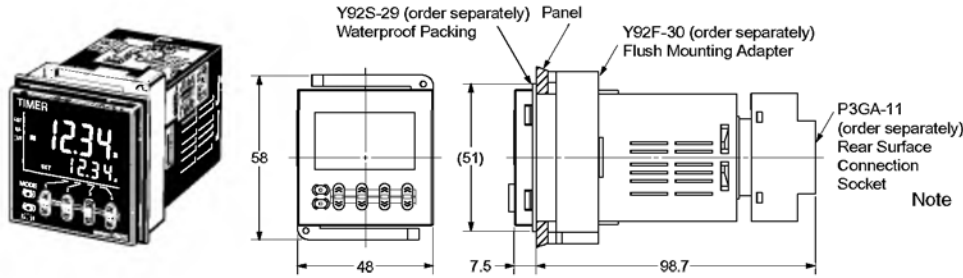

Panel Cutouts

Panel cutouts are as shown below. (according to DIN43700).

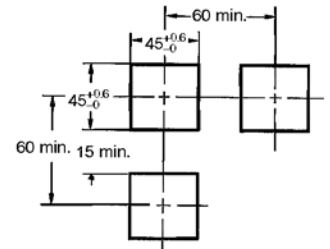

- Note
1. The mounting panel thickness should be 1 to 5 mm.
 2. To allow easier operability, it is recommended that Adapters are mounted so that the gap between sides with hooks is at least 15 mm.
 3. It is possible to mount timers side by side, but only in the direction without the hooks.

H5CX-A11D/-A11SD (Adapter and Waterproof Packing Ordered Separately)

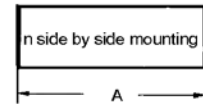
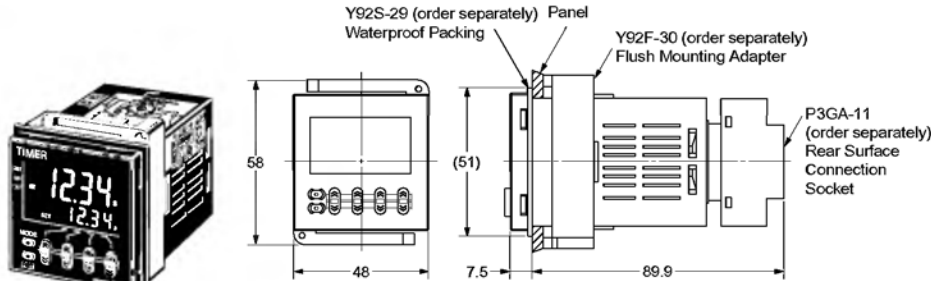

$$A = (48n - 2.5) \begin{matrix} +1 \\ 0 \end{matrix}$$

With Y92A-48F1 attached.

$$A = \{48n - 2.5 + (n-1) \times 4\} \begin{matrix} +1 \\ 0 \end{matrix}$$

With Y92A-48 attached.

$$A = (51n - 5.5) \begin{matrix} +1 \\ 0 \end{matrix}$$

H5CX-L8 (Adapter and Waterproof Packing Ordered Separately)

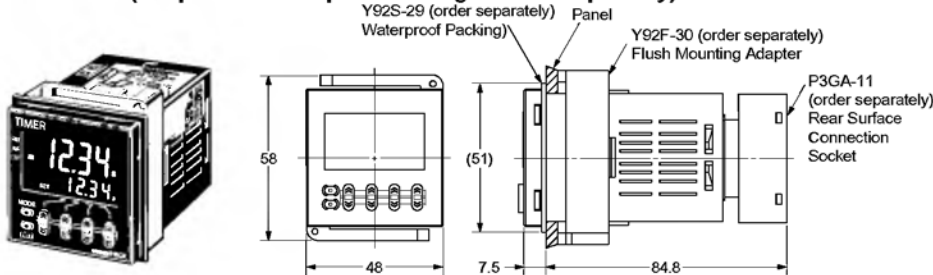

■ Dimensions with Front Connecting Socket

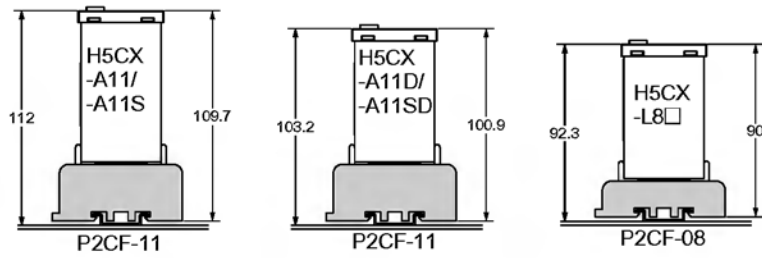

Note: These dimensions vary with the kind of DIN track (reference value).

Installation

Terminal Arrangement

Confirm that the power supply meets specifications before use.

H5CX-A/-AD

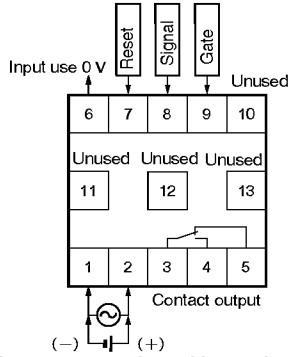

The power supply and input circuit are not insulated. Terminals 1 and 6 of the H5CX-AD are connected internally.

H5CX-AS/-ASD

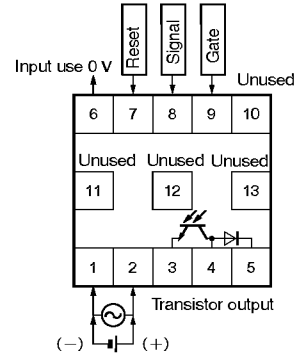

The power supply and input circuit are not insulated. Terminals 1 and 6 of the H5CX-ASD are connected internally.

H5CX-A11/-A11D

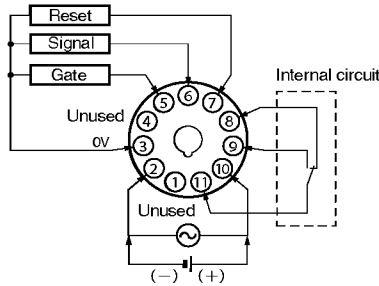

The power supply and input circuit of the H5CX-A11 have basic insulation. The power supply and input circuit of the H5CX-A11D are not insulated. Terminals 2 and 3 of the H5CX-A11D are connected internally.

H5CX-A11S/-A11SD

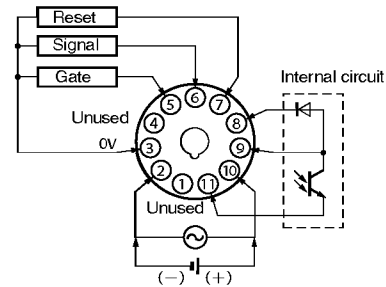

The power supply and input circuit of the H5CX-A11S have basic insulation. The power supply and input circuit of the H5CX-A11SD are not insulated. Terminals 2 and 3 of the H5CX-A11SD are connected internally.

H5CX-L8/-L8D

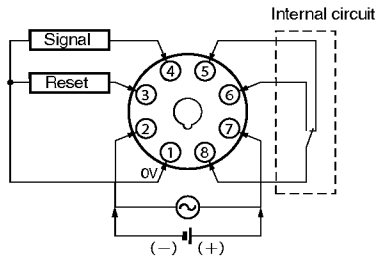

The power supply and input circuit are not insulated. Terminals 1 and 2 of the H5CX-L8D are connected internally.

H5CX-L8S/-L8SD

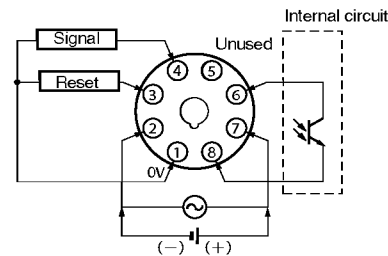

The power supply and input circuit are not insulated. Terminals 1 and 2 of the H5CX-L8SD are connected internally.

Note: Do not connect unused terminals as relay terminals.

Input Circuits

Start, Reset, and Gate Input

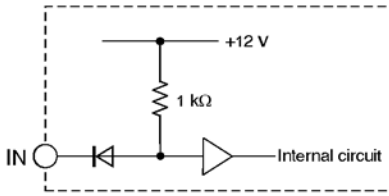

Input Connections

The inputs of the H5CX-A□/A11□ are no-voltage (short-circuit or open) inputs or voltage inputs.

The input of the H5CX-L8□ is no-voltage input only.

No-voltage Inputs (NPN Inputs)

Open Collector

(Connection to NPN open collector output sensor)

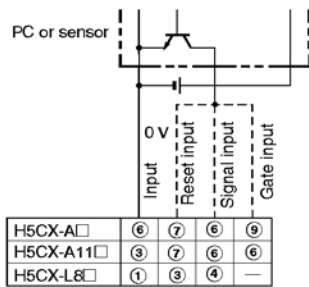

Operate with transistor ON

Voltage Output

(Connection to a voltage output sensor)

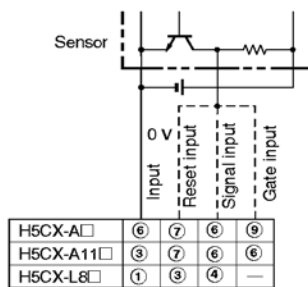

Operate with transistor ON

Contact input

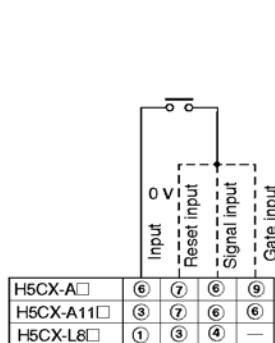

Operate with relay ON

No-voltage Input Signal Levels

No-contact input	Short-circuit level
	Transistor ON Residual voltage: 2 V max. Impedance when ON: 1 KΩ max. (the leakage current is 5 to 20 mA when the impedance is 0 Ω)
Contact input	Open level
	Transistor OFF Impedance when OFF: 100 KΩ min.
Contact input	Use contact which can adequately switch 1 mA at 5 V Maximum applicable voltage: 30 VDC max.

Two-wire Sensor

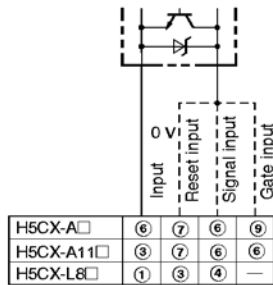

Operate with transistor ON

Applicable Two-wire Sensor

Leakage current: 1.5 mA max.
Switching capacity: 5 mA min.
Residual voltage: 3 VDC max.
Operating voltage: 10 VDC

Voltage Inputs (PNP Inputs)

No-contact Input (NPN Transistor)

(Connection to NPN open collector output sensor)

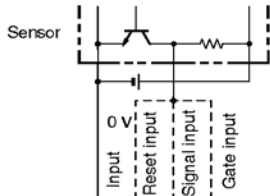

H5CX-A□	⑥	⑦	⑧	⑨
H5CX-A11□	③	⑦	⑥	⑥

Operate with transistor OFF

No-contact Input (PNP Transistor)

(Connection to PNP open collector output sensor)

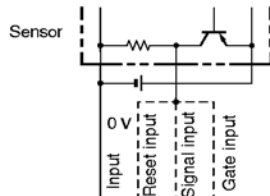

H5CX-A□	⑥	⑦	⑧	⑨
H5CX-A11□	③	⑦	⑥	⑥

Operate with transistor ON

Contact input

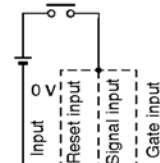

H5CX-A□	⑥	⑦	⑧	⑨
H5CX-A11□	③	⑦	⑥	⑥

Operate with relay ON

Voltage Input Signal Levels

- High level (Input ON): 4.5 to 30 VDC
- Low level (Input OFF): 0 to 2 VDC
- Maximum applicable voltage: 30 VDC max.
- Input resistance: Approx. 4.7 kΩ

Note: Power circuit is not insulated from the input circuit, except for H5CX-A11/-A11S, which have basic insulation. For wiring, refer to *Precautions*.

Accessories (Order Separately)

Note: All units are in millimeters unless otherwise indicated.

Track Mounting/Front Connecting Socket

P2CF-08

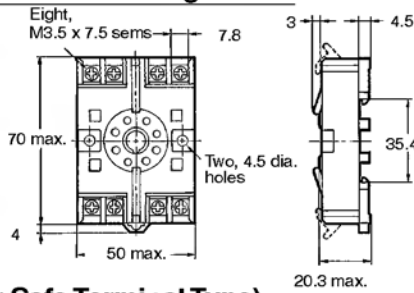
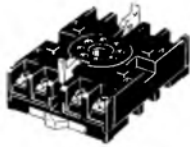

Terminal Arrangement/ Internal Connections (Top View)

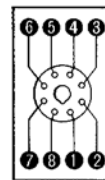

Surface Mounting Holes

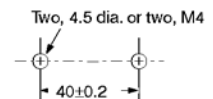

P2CF-08-E (Finger Safe Terminal Type) Conforming to VDE0106/P100

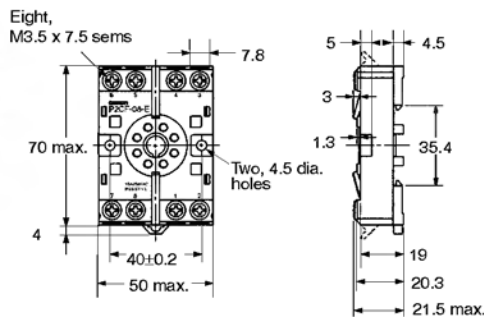

Track Mounting/Front Connecting Socket

P2CF-11

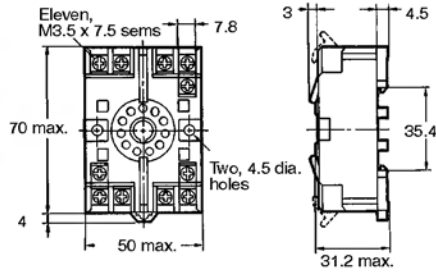
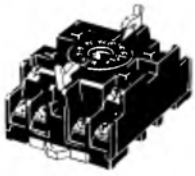

**Terminal Arrangement/
Internal Connections
(Top View)**

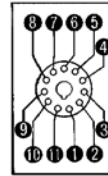

Surface Mounting Holes

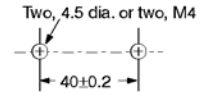

P2CF-11-E (Finger Safe Terminal Type)

Conforming to VDE0106/P100

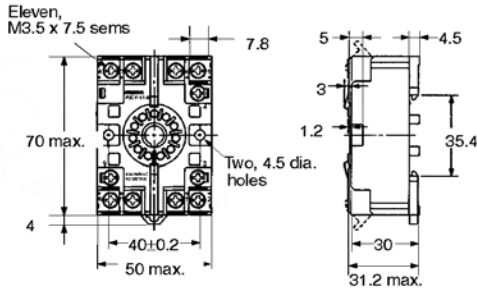

Back Connecting Socket

P3G-08

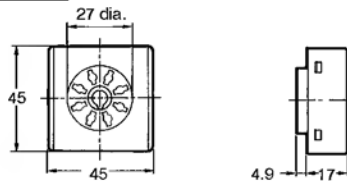
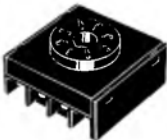

**Terminal Arrangement/
Internal Connections
(Bottom View)**

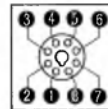

P3GA-11

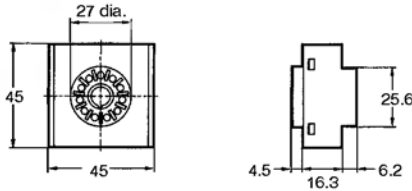

**Terminal Arrangement/
Internal Connections
(Bottom View)**

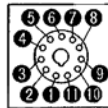

Finger Safe Terminal Cover

Conforming to VDE0106/P100

Y92A-48G

(Attachment for P3G-08/P3GA-11 Socket)

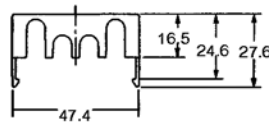
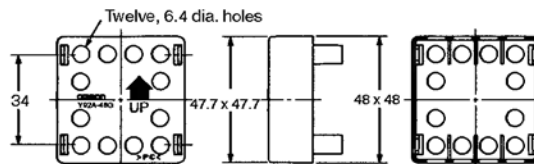
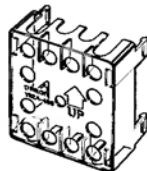

Hard Cover
Y92A-48

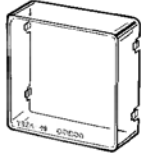

Soft Cover
Y92A-48F1

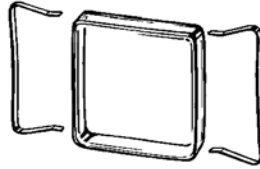

Flush Mounting Adaptor
(provided with H5CX-A□ models)

Y92F-30

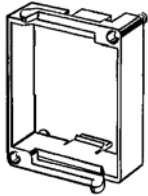

Waterproof Packing
(provided with H5CX-A□ models)

Y92S-29

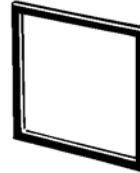

Mounting Track
PFP-100N, PFP-50N

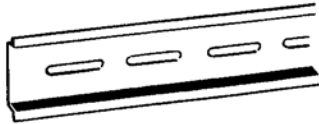

PFP-100N2

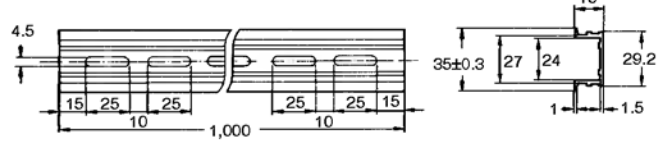
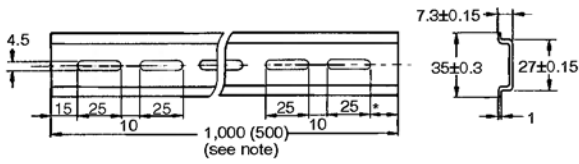
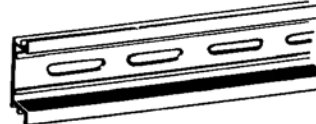

Note: The values shown in parentheses are for the PFP-50N.

End Plate
PFP-M

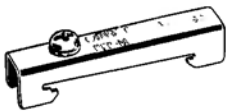

Spacer
PFP-S

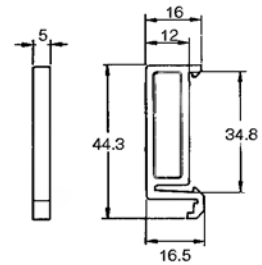
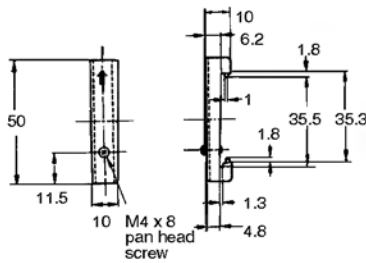
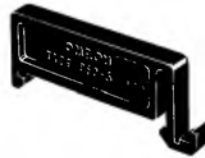

Precautions

⚠ Caution

Do not use the product in locations subject to flammable or explosive gases. Doing so may result in explosion.

The service life of the output relays depends on the switching capacity and switching conditions. Consider the actual application conditions and use the product within the rated load and electrical service life. Using the product beyond its service life may result in contact deposition or burning.

Do not disassemble, repair, or modify the product. Doing so may result in electric shock, fire, or malfunction.

Do not allow metal objects or conductive wires to enter the product. Doing so may result in electric shock, fire, or malfunction.

■ Power Supplies

For the power supply of an input device of the H5CX (except for H5CX-A11□), use an isolating transformer with the primary and secondary windings mutually isolated and the secondary winding not grounded.

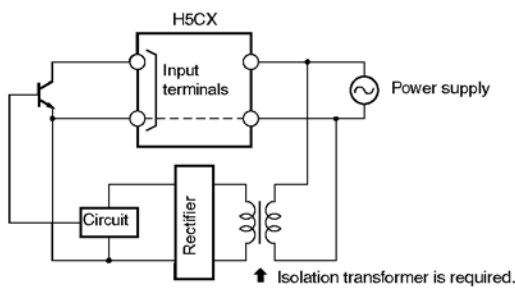

Make sure that the voltage is applied within the specified range, otherwise the internal elements of the Timer may be damaged.

Do not touch the input terminals while power is supplied. The H5CX (except for H5CX-A11/-A11S) has a transformer-less power supply and so touching the input terminals with power supplied may result in electric shock.

When turning the power ON and OFF, input signal reception is possible, unstable, or impossible as shown in the diagram below.

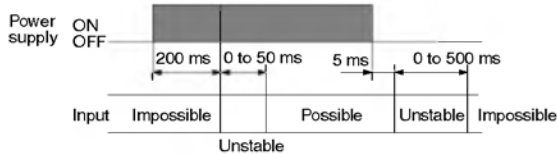

Turn the power ON and OFF using a relay with a rated capacity of 10 A minimum to prevent contact deterioration due to inrush current caused by turning the power ON and OFF.

Apply the power supply voltage through a relay or switch in such a way that the voltage reaches a fixed value immediately, otherwise they may not be reset or a timer error may result.

Be sure that the capacity of the power supply is large enough, otherwise the Timer may not start due to inrush current (approx. 10 A) that may flow for an instant when the Timer is turned on.

Make sure that the fluctuation of the supply voltage is within the permissible range.

■ Timer Control with Power Start

To allow for the startup time of peripheral devices (sensors, etc.), the H5CX starts timing operation between 200 ms to 260 ms after power is turned ON. For this reason, in operations where timing starts from power ON, the time display will actually start from 250 ms. If the set value is 249 ms or less, the time until output turns ON will be a fixed value between 200 and 250. (Normal operation is possible for set value of 250 ms or more.) In applications where a set value of 249 ms or less is required, use start timing with signal input.

When the H5CX is used with power start in F mode (i.e., accumulative operation with output on hold), there will be a timer error (approximately 100 ms each time the H5CX is turned ON) due to the characteristics of the internal circuitry. Use the H5CX with signal start if timer accuracy is required.

■ Input/Output

The H5CX (except for H5CX-A11/-A11S) uses transformerless power supply. When connecting a relay or transistor as an external signal input device, pay attention to the following points to prevent short-circuiting due to a sneak current to the transformerless power supply. If a relay or transistor is connected to two or more Timers, the input terminals of those Timers must be wired properly so that they will not differ in phase, otherwise the terminals will be short-circuited to one another.

Incorrect

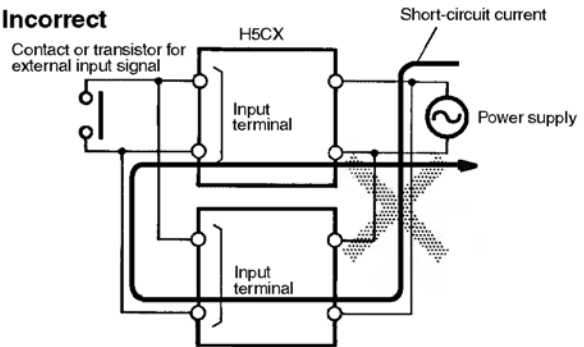

Correct

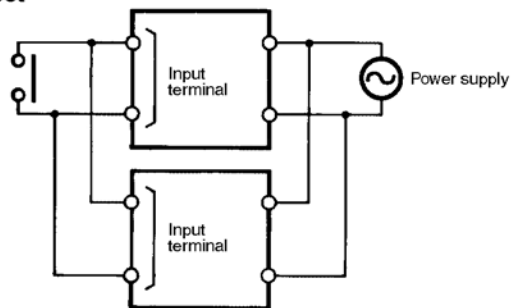

It is impossible to provide two independent power switches as shown below regardless of whether or not the Timers are different in phase.

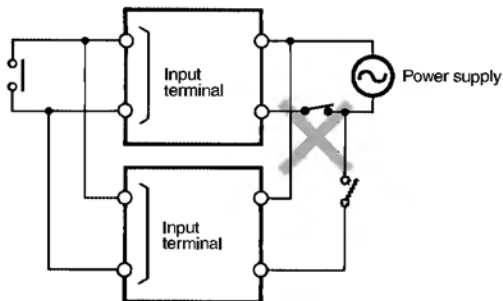

■ Transistor Output

The transistor output of the H5CX is insulated from the internal circuitry by a photocoupler, so the transistor output can be used as both NPN and PNP output.

The diode connected to the collector of the output transistor is used to absorb inverted voltage that is generated when an inductive load is connected to the H5CX.

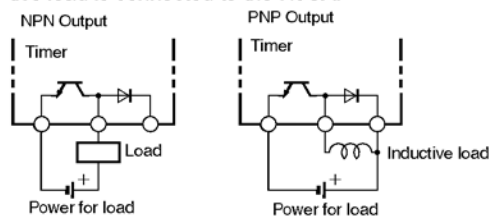

■ Self-diagnostic Function

The following displays will appear if an error occurs.

Confirm the error type using the display, and take the appropriate countermeasures.

Main display	Sub-display	Error	Correction
E2	No display	Memory (RAM)	Reset the power supply. If normal operation is still not restored, replacement or repair is necessary. If normal operation is restored, the cause may have been noise.
E2	5Ln	Memory (EEP) (See note)	Reset to the factory settings using the reset key.
E1	No display	CPU	Either press the reset key or reset the power supply.

Note: This includes times when the life of the EEPROM has expired.

■ Changing the Set Values

When changing the set value during a timing operation, the output will turn ON if the set value is changed as follows because of the use of a constant read-in system:

Elapsed time mode: Present value \geq set value

Remaining time mode: Elapsed time \geq set value (The present value is set to 0.)

Note: When in the remaining time mode, the amount the set value is changed is added to or subtracted from the present value.

■ Operation with a Set Value of 0

Operation with a set value of 0 will vary with the output mode. Refer to the *Timing Charts*.

■ DIP Switch Setting

Ensure that the power is turned OFF before changing DIP switch settings. Changing DIP switch settings with the power turned ON may result in electric shock due to contact with terminals subject to high voltages.

■ Power Failure Backup

All data is stored in the EEPROM when there is power failure. The EEPROM can be overwritten more than 100,000 times.

Operating mode	Overwriting timing
A-3, F mode	When power is turned OFF.
Other mode	When settings are changed.

■ Response Delay Time When Resetting (Transistor Output)

The following table shows the delay from when the reset signal is input until the output is turned OFF.

(Reference value)

Minimum reset signal width	Output delay time
1 ms	0.8 to 1.2 ms
20 ms	15 to 25 ms

■ Wiring

Wiring input lines in the same conduit as power lines or other high-voltage lines may result in malfunction due to noise. Wire the input lines separately, away from lines carrying high-voltages. In addition, make the input wiring as short as possible and use shield lines or metal wiring conduits.

■ Mounting

Dense mounting may result in a reduction in the service life of internal parts.

Tighten the two mounting screws on the Adaptor. Tighten them alternately, a little at a time, so as to keep them at an equal tightness.

The H5CX's panel surface is water-resistive (conforming to NEMA 4 and IP66). In order to prevent the internal circuit from water penetration through the space between the timer and operating panel, attach a waterproof packing between the timer and installation panel and secure the waterproof packing with the Y92F-30 flush-mounting adapter.

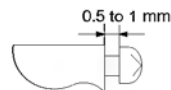

It is recommended that the space between the screw head and the adapter should be 0.5 to 1 mm.

■ Operating Environment

- Use the product within the ratings specified for submerging in water, and exposure to oil.
- Do not use the product in locations subject to vibrations or shocks. Using the product in such locations over a long period may result in damage due to stress.
- Do not use the product in locations subject to dust, corrosive gases, or direct sunlight.
- Separate the input signal devices, input signal cables, and the product from the source of noise or high-tension cables producing noise.

- Separate the product from the source of static electricity when using the product in an environment where a large amount of static electricity is produced (e.g., forming compounds, powders, or fluid materials being transported by pipe).
- Organic solvents (such as paint thinner), as well as very acidic or basic solutions might damage the outer casing of the Timer.
- Use the product within the ratings specified for temperature and humidity.
- Do not use the product in locations where condensation may occur due to high humidity or where temperature changes are severe.
- Store at the specified temperature. If the H5CX has been stored at a temperature of less than -10°C , allow the H5CX to stand at room temperature for at least 3 hours before use.
- Leaving the H5CX with outputs ON at a high temperature for a long time may hasten the degradation of internal parts (such as electrolytic capacitors). Therefore, use the product in combination with relays and avoid leaving the product as long as more than 1 month with the output turned ON.

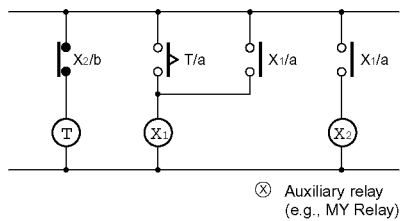

■ Insulation

There is no insulation between power supply and input terminals (except for H5CX-A11/-A11S.)

Basic insulation between power supply and output terminals.

Input and output terminals are connected to devices without exposed charged parts.

Input and output terminals are connected to devices with basic insulation that is suitable for the maximum operating voltage.

Appendix

■ Using the Operation Keys

Timer Operation

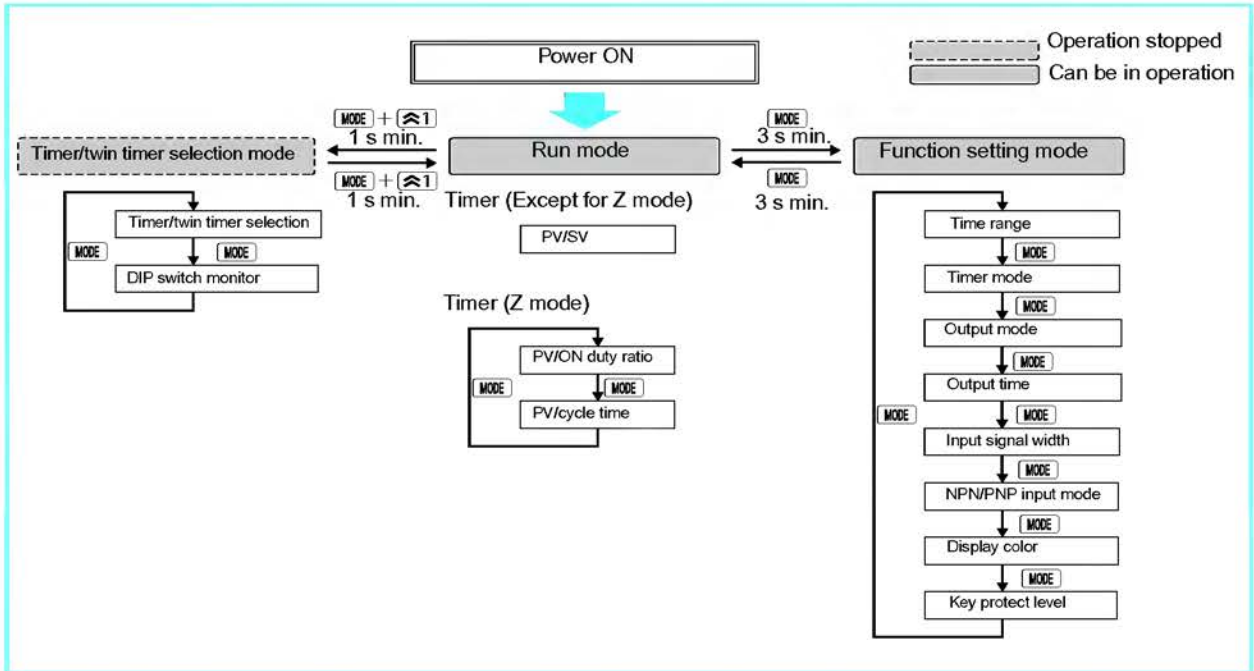

Twin Timer Operation

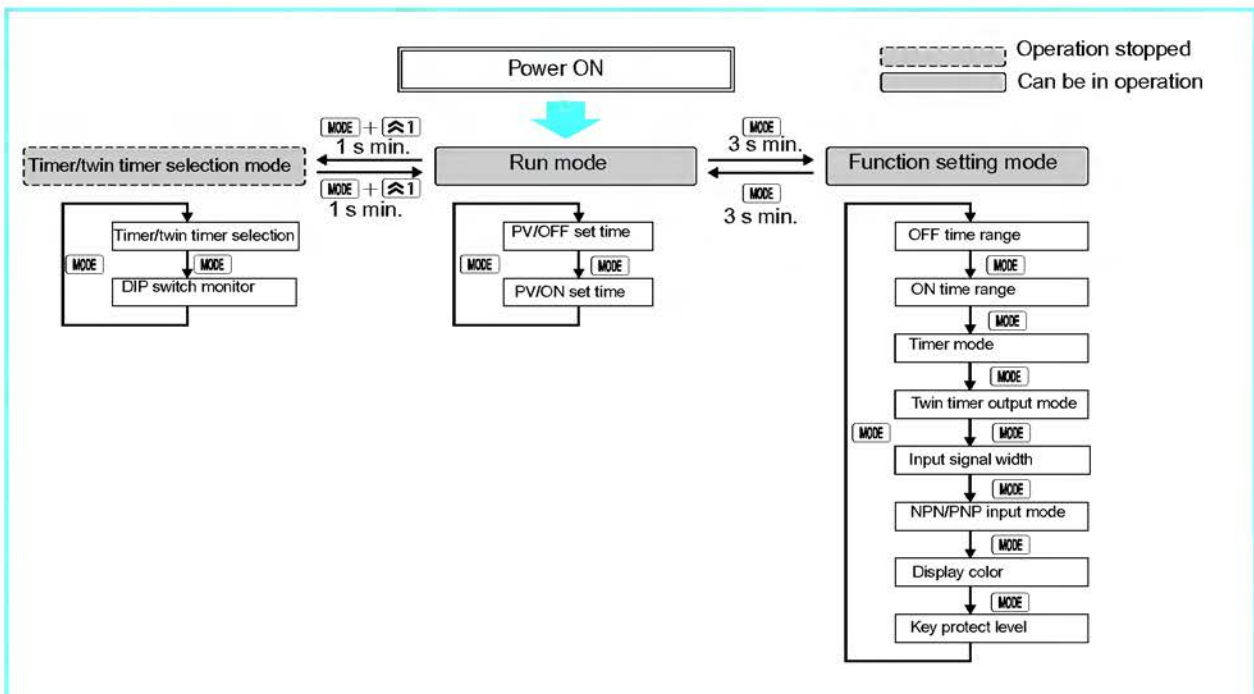

- Note:**
1. All setting changes are performed using the [▲] and [▼] keys.
 2. The above flowcharts outline the procedure for all models. For details on specific models, refer to page 12 (timer operation) or page 16 (twin timer operation).

■ List of Settings

Fill in your set values in the set value column of the following tables and utilize the tables for quick reference.

Timer/Twin Timer Selection Mode

Parameter name	Parameter	Setting range	Default value	Unit	Set value
Timer/Twin Timer selection	FUNC	TCR/TCn	TCR	---	
DIP switch monitor	dCP	on/off	off	---	

Settings for Timer Operation

Run Mode when Output Mode Is Not Z

Parameter name	Parameter	Setting range	Default value	Unit	Set value
Present value, set value	Set value	0.00 to 99.99 (Time range: --,--s)	0.00	s	
		0.0 to 999.9 (Time range: ---, -s)	0.0	s	
		0 to 9999 (Time range: ----s)	0	s	
		0:00 to 99:59 (Time range: --min--s)	0:00	min; s	
		0.0 to 999.9 (Time range: ---, -min)	0.0	min	
		0 to 9999 (Time range: ----min)	0	min	
		0:00 to 99:59 (Time range: --h--min)	0:00	h; min	
		0.0 to 999.9 (Time range: ---, -h)	0.0	h	
		0 to 9999 (Time range: ----h)	0	h	
		0.000 to 9.999 (Time range: -,---s)	0.000	s	
Present value		Same as set value	Same as left	Same as left	

Run Mode when Output Mode = Z

Parameter name	Parameter	Setting range	Default value	Unit	Set value
Present value, cycle time	Cycle time	0.00 to 99.99 (Time range: --,--s)	0.00	s	
		0.0 to 999.9 (Time range: ---, -s)	0.0	s	
		0 to 9999 (Time range: ----s)	0	s	
		0:00 to 99:59 (Time range: --min--s)	0:00	min; s	
		0.0 to 999.9 (Time range: ---, -min)	0.0	min	
		0 to 9999 (Time range: ----min)	0	min	
		0:00 to 99:59 (Time range: --h--min)	0:00	h; min	
		0.0 to 999.9 (Time range: ---, -h)	0.0	h	
		0 to 9999 (Time range: ----h)	0	h	
		0.000 to 9.999 (Time range: -,---s)	0.000	s	
Present value		Same as cycle time above	Same as left	Same as left	
Present value, ON duty ratio	ON duty ratio	0 to 100	0	%	
	Present value	Same as cycle time above	Same as left	Same as left	

Function Setting Mode

Parameter name	Parameter	Setting range	Default value	Unit	Set value
Time range	TCRr	--s/--s/---s/--min--s/--min/----min/ --h--min/--h/--h/--s		---	
Timer mode	TCRn	UP/dōn	UP	---	
Output mode	OUTn	R/R-1R-21R-31b1b-1d1E1F1E	R	---	
Output time	ōTCn	HōLd/0.01 to 99.99	HōLd	s	
Input signal width	CFLe	20rS/1rS	20rS	---	
NPN/PNP input mode	CRōd	nPN/PnP	nPN	---	
Display color	CLr	rEd/ōrGr-ōō-r	rEd	---	
Key protect level	YPLe	1P-11P-21P-31P-41P-5	1P-1	---	

Settings for Twin Timer Operation

Run Mode

Parameter name		Parameter	Setting range	Default value	Unit	Set value
Present value, OFF set time	OFF set time		0.00 to 99.99 (Time range: --,-s)	0.00	s	
			0.0 to 999.9 (Time range: ---,-s)	0.0	s	
			0 to 9999 (Time range: ----s)	0	s	
			0:00 to 99:59 (Time range: --min--s)	0:00	min; s	
			0.0 to 999.9 (Time range: ---,-min)	0.0	min	
			0 to 9999 (Time range: ----min)	0	min	
			0:00 to 99:59 (Time range: --h--min)	0:00	h; min	
			0.0 to 999.9 (Time range: ---,-h)	0.0	h	
			0 to 9999 (Time range: ----h)	0	h	
	0.000 to 9.999 (Time range: -,---s)	0.000	s			
	Present value		Same as OFF set time above	Same as left	Same as left	
Present value, ON set time	ON set time		Same as OFF set time above	Same as left	Same as left	
	Present value		Same as OFF set time above	Same as left	Same as left	

Function Setting Mode

Parameter name	Parameter	Setting range	Default value	Unit	Set value
OFF time range	oFtr	--,-s/--,-s/---s/--min--s/--,-min/----min/ --h--min/--,-h/---h/--,-s	--,-s	---	
ON time range	oNtr	--,-s/--,-s/---s/--min--s/--,-min/----min/ --h--min/--,-h/---h/--,-s	--,-s	---	
Timer mode	tCn	UP/dOn	UP	---	
ON/OFF start mode	tStn	tOFF/tOn	tOFF	---	
Input signal width	iFLt	20rS/1rS	20rS	---	
NPN/PNP input mode	iMod	nPN/pnP	nPN	---	
Display color	EdLr	rEd/orG/r-d/o-r	rEd	---	
Key protect level	kYPrL	1P-11P-21P-31P-41P-5	1P-1	---	

ALL DIMENSIONS SHOWN ARE IN MILLIMETERS.

To convert millimeters into inches, multiply by 0.03937. To convert grams into ounces, multiply by 0.03527.

Cat. No. L101-E1-1 **In the interest of product improvement, specifications are subject to change without notice.**

OMRON Corporation

Industrial Automation Company

Measuring and Supervisory Controls Department
Shiokoji Horikawa, Shimogyo-ku
Kyoto, 600-8530 Japan

Phone: (81)75-344-7108 Fax: (81)75-344-7189

Printed in Japan
0501-3M (0501)